



Volvo Chassis - D12C, D12D, D11F, D13F, D16D, D16F Engines - Copper Injector Sleeves, Replacement Procedure And Information (Flat Tip Injectors) - US04 To US07 Emissions



> Internal Content

NOTE: Copper sleeves are the only option for US04 emissions engines. The Conical (Stainless Steel) Sleeve and Injector upgrade is only an option for US07 emissions level.

For NBR Washers:

- If the top rim of the injector sleeve has ridges machined into the surface, the NBR washer **should** be used.

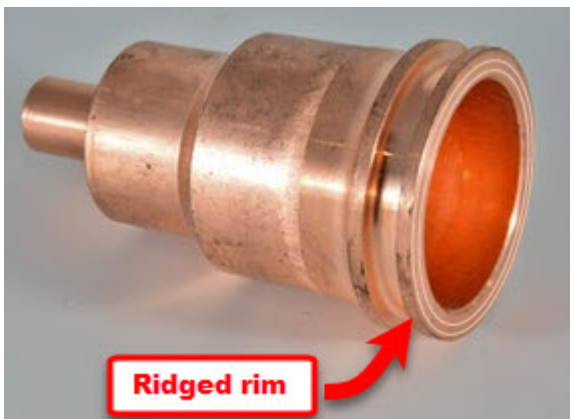

- If the top rim of the injector sleeve is smooth, the NBR washer **should not** be used.

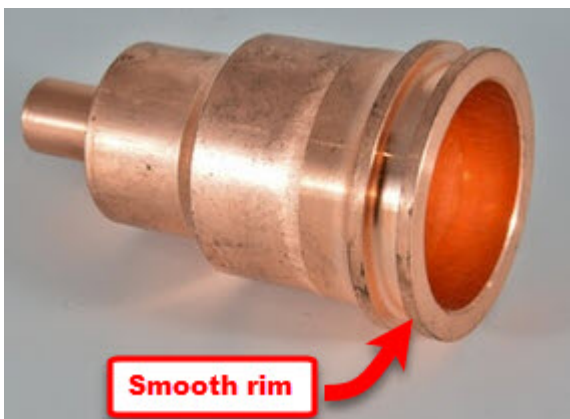

Live UI d tools were released for the removal and installation of Copper
injector Sleeves. Current information can be found in [IMPACT](#) under the
Service tab, operation 2270-02-02-04 Sleeve, Engine Injector

Service Lab, operation 2379-03-02-04 Sleeve, engine injector,

Replacement (Copper).

 Tags [k73434141](#)

Related links and attachments

No links or attachments available

Feedback

[Give feedback](#)

to help improve the content of this article

23770-2 Sleeve, Engine Injector, Replacement (Copper)

You must read and understand the precautions and guidelines in Service Information, Function Group 20, Engine Safety Practices before performing this procedure. If you are not properly trained and certified in this procedure, ask your supervisor for training before you perform it.

Special tools: 9996049, 9996956, 9998249, 9998250, 9998251, 9998252, 9998253, 88800014, 88800054, 88800196, 88800281, 88800282, 85112740, J42885, PT2900, DBT2V700

Removal



Conical and copper sleeves should not be mixed in the same engine. The same type of sleeve must be used in all six cylinders. Mixing sleeves can result in damage to the engine.

1

Secure the vehicle for service by parking it on a flat level surface, applying the parking brake, chocking the rear wheels, and placing the transmission in neutral or park.

2

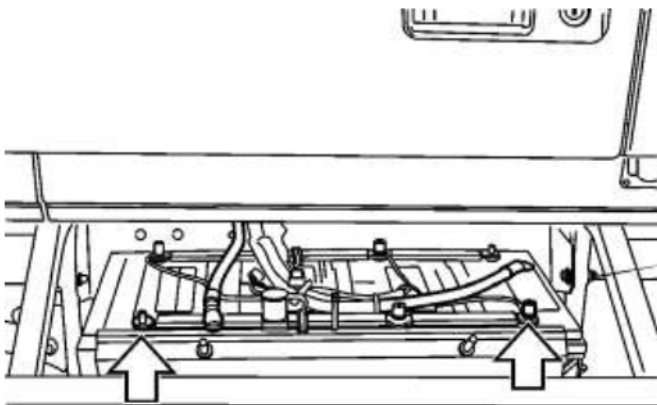

Disconnect all cables from the negative (ground) battery terminals to prevent personal injury from electrical shock and prevent damage to electrical components.

3

Drain the coolant from the radiator and engine using the coolant extractor.

Note: An alternate method is to connect the drain hose to the drain fitting and drain the coolant.

Special tools: [9996049](#), [DBT2V700](#), [85112740](#)

4

Clean around the fuel supply line fitting on the filter housing. Loosen the fuel line at the filter housing to allow fuel to

drain from the cylinder head. Allow the fuel to drain into a suitable container.

5

Remove the valve cover. Refer to Function Group 211 for procedure.

Note: Rotate the valve cover as needed, to clear the camshaft gear and damper.

Note: Dependent upon chassis, engine cover may need to be removed for clearance to remove valve cover.

6

Remove the rocker shaft. Refer to Function Group 214 for procedure.

7

Remove the engine brake control valve, if equipped. Refer to Function Group 253 for procedure.

8

Thoroughly clean around the engine injectors that are to be removed. Remove the engine injectors. Refer to Function Group 237 for procedure.

9

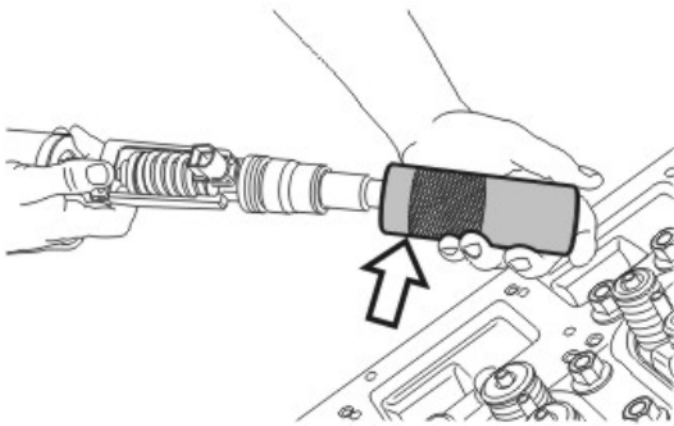

Install the protective sleeve over the engine injector to prevent damage.

Special tools: [9998249](#)

10

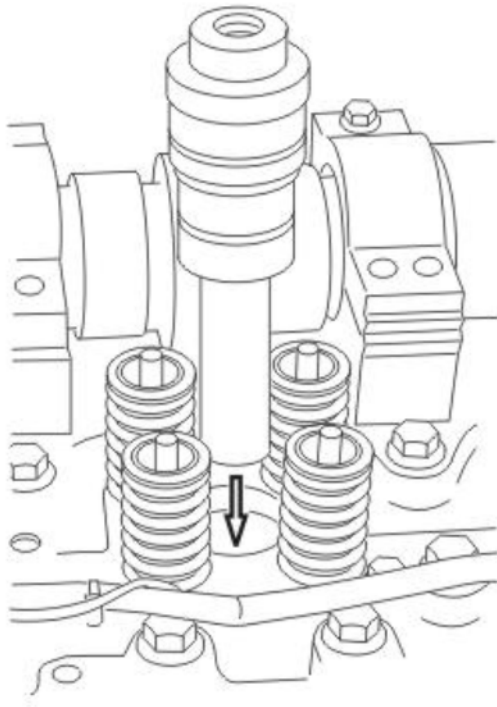

Clean the protective plug and install it into the injector bore of the cylinder head to protect it from debris. Using compressed air, clean out the injector hold down bolt holes.

Danger

Compressed air can cause serious personal injury. When using compressed air for cleaning, wear a protective face shield, protective clothing and protective shoes. Pressurized water could cause particles and/or hot water to be sprayed in your direction and cause personal injury. The maximum air pressure must be below 200 kPa (30 psi) for cleaning purposes.

Caution

It is very important to clean out injector yoke bolt holes. If fluid is not cleaned out, hydraulic lock can occur when tightening tools or injectors and can result in lack of low clamp load and cylinder head cracking at the injector yoke bolt hole.

Note: Make sure the protective plug is clean so it does not introduce dirt or contaminants into the engine.

Special tools: [9998251](#)

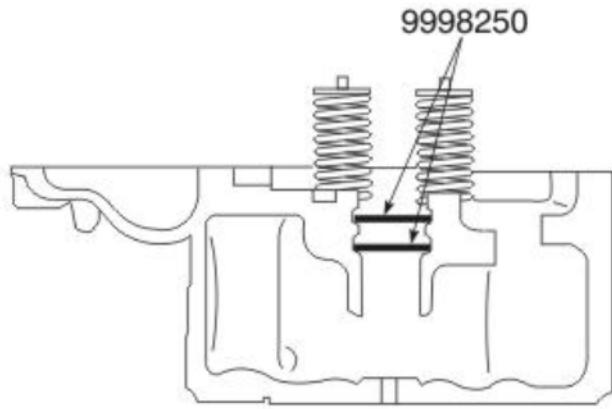

Install two sealing rings to prevent dirt from entering the fuel gallery when the copper sleeve is removed.

Note: Two sealing rings are required to cover the fuel gallery.

Special tools: [9998250](#)

12

Install the flywheel turning tool. Turn the flywheel until the piston is at its lowest position in the cylinder. Confirm the piston is at the lowest position in the cylinder by using a 40 cm (16 inch) piece of straight stiff wire in the injector hole of the cylinder.

Note: This is to ensure that the copper sleeve tapping tool does not damage the piston due to tool length.

Note: Ensure the turning tool is well greased before attempting to turn the flywheel.

Note: If it is necessary to replace other copper sleeves, continue the procedure on pairs of companion cylinders (1 and 6, 2 and 5, 3 and 4). It is necessary to rotate the crankshaft and place each pair of companion cylinders at the lowest position in the cylinder.

Special tools: [88800014](#), [9996956](#)

13

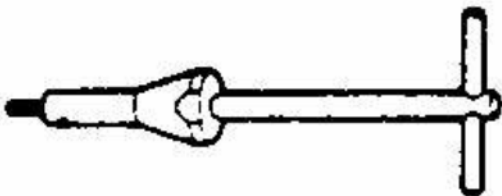

Tap Handle, 9998252

Insert the 8.5 mm forming tap into the tap handle until it stops. Secure the upper set screw first against one of the flats on the forming tap, then secure the lower set screw.

 **Caution**

If the copper sleeve is not completely tapped through to the opening of the tip, an end piece of the tip can break off and fall into the cylinder during removal. These types of failures are not covered by warranty.

Special tools: [88800281](#), [9998252](#)

14



Completely coat the 8.5 mm tap with fresh, extreme pressure NLGI #2 grease or equivalent.

Note: Forming taps require extreme pressure grease due to the cold working process used to form threads.

Special tools: [88800281](#)

15

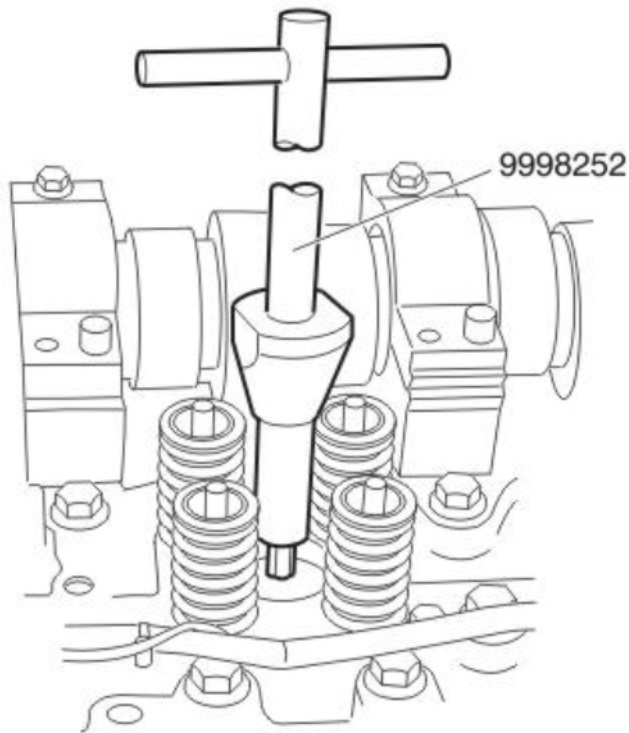

Install tap holder in the engine injector bore. Apply moderate downward force to get the tap started while turning the tap handle clockwise. Continue turning in the same direction, without reversing, until the copper sleeve is tapped all the way through. The shoulder of the tap handle bottoms on the copper sleeve. Ensure that the tap is completely through the copper sleeve

 **Caution**

If threads are not cut completely through the tip of the copper sleeve, the tip can break off and fall into the cylinder. This can result in damage to the cylinder, piston, valves or turbocharger. These types of failures are not covered by warranty.

Special tools: [9998252](#), [88800281](#)

16

Remove the tap and tapping tool.

17

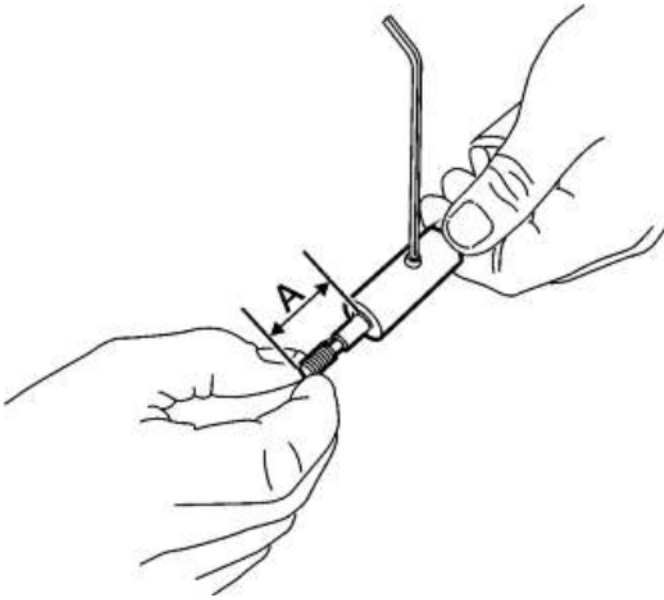

Install the extractor bolt into the end of the extractor tool. Adjust the bolt until it extends approximately 22 mm (0.9 inch) beyond the end of the tool (dimension A).

Special tools: [88800282](#), [9998253](#)

18

Tighten the set screw of the extractor tool to secure the bolt. Make sure that the set screw is seated against the flat part of the extractor bolt.

19

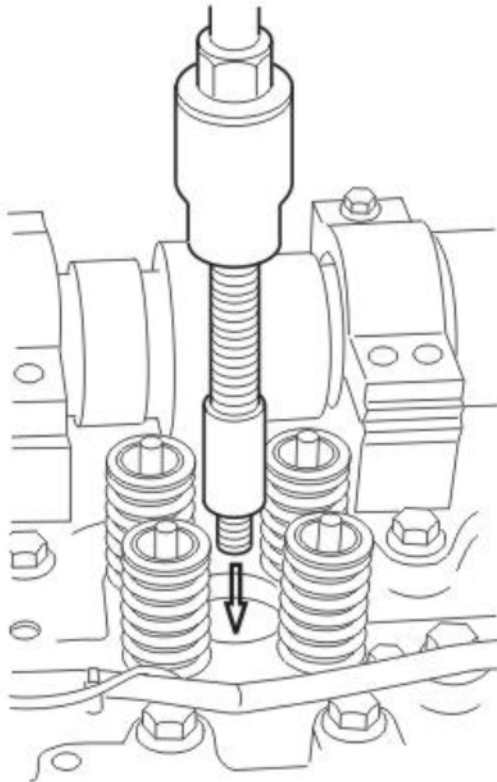

Make sure the extractor bolt is threaded completely into the copper sleeve before attempting to remove it or the tip of the sleeve may break off as it is removed. This broken sleeve tip can seriously damage the piston, valves or turbocharger. These types of failures are not covered by warranty.

Lubricate the threads of the forcing screw on the puller. Lubricate under the face of the nut. Place the extractor tool with the bolt into the injector bore. Make sure the nut on the spindle is backed off so that the threaded end can be completely installed through the copper sleeve tip. Hand tighten until the bolt bottoms out in the sleeve.

Note: If it is necessary to replace other copper sleeves, continue the procedure on pairs of companion cylinders (1 and 6, 2 and 5, 3 and 4). It is necessary to rotate the crankshaft and place each pair of companion cylinders at the lowest position in the cylinder.

20

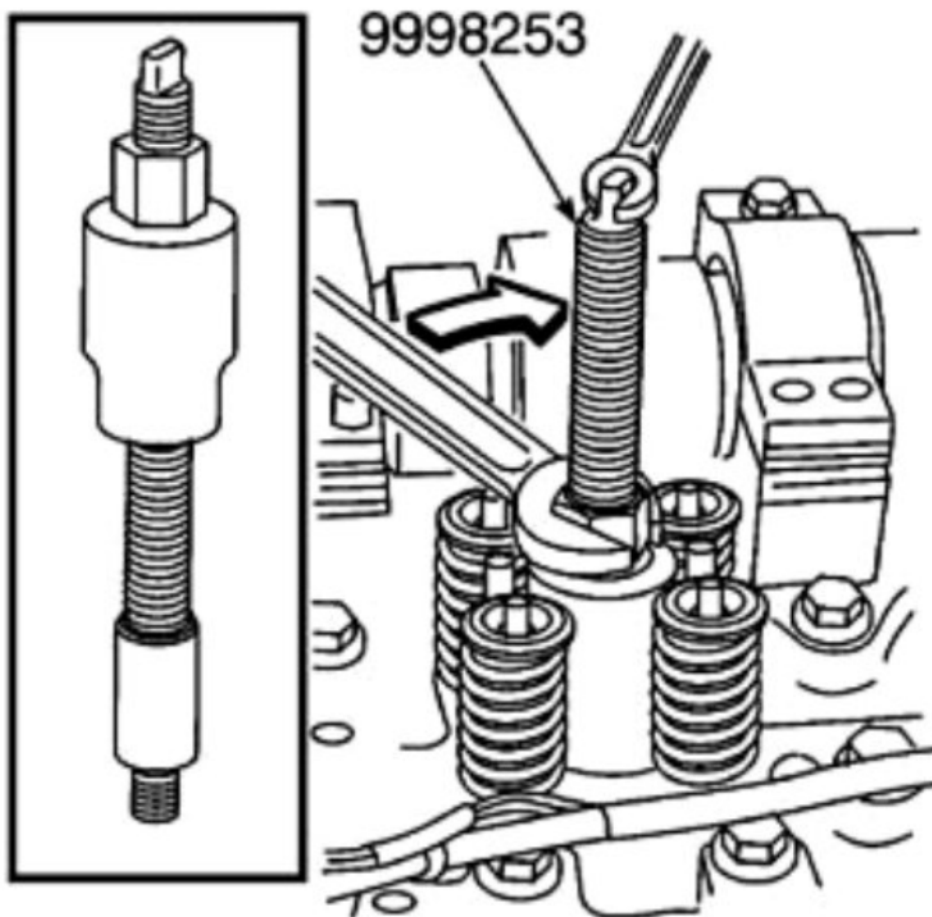

While holding the top of the tool stationary, turn the large nut clockwise to extract the copper sleeve.

Note: When the copper sleeve is removed, make sure that the extractor bolt is extended at least one thread beyond the copper sleeve. If not, make sure that no part of the copper sleeve has broken off and fallen into the cylinder.



Do not use air tools to remove copper sleeves, or damage to the injector bore can result.

Special tools: [9998253](#)

Copyright to this documentation belongs to the Volvo Group. No reproduction, copying, change, amendment or other similar disposal is entitled without prior written consent by the Volvo Group

The information contained herein is current at the time of its original distribution, but is subject to change. The reader is advised that printed copies are uncontrolled.

21

Absorb any remaining coolant with a lint-free cloth.

Note: Check that the piston is free of any fluids.

22

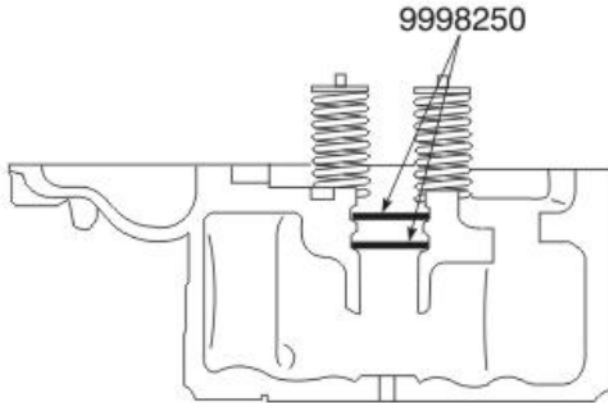

Attach a small diameter air line to a wet / dry shop vacuum nozzle that can reach into the coolant passages in the injector sleeve bore. Remove all remaining fuel and coolant. A lint free paper shop towel can also be used to absorb liquid. All fluids must be completely removed before proceeding. Remove the two sealing rings from the fuel passage when all fluid has been removed.

Note: Do not use a shop rag as it could possibly contain contaminants, metal chips, etc.

Special tools: [9998250](#), [PT2900](#)

23

Inspect condition of the J-42885-25 O-rings before installing the protective sleeve. If necessary, replace O-rings (part numbers 507688 and 10914). Install the injector bore sealing tool, J-42885-25, to protect the fuel passage area and prevent debris from entering.

Special tools: [J-42885-25](#)

24

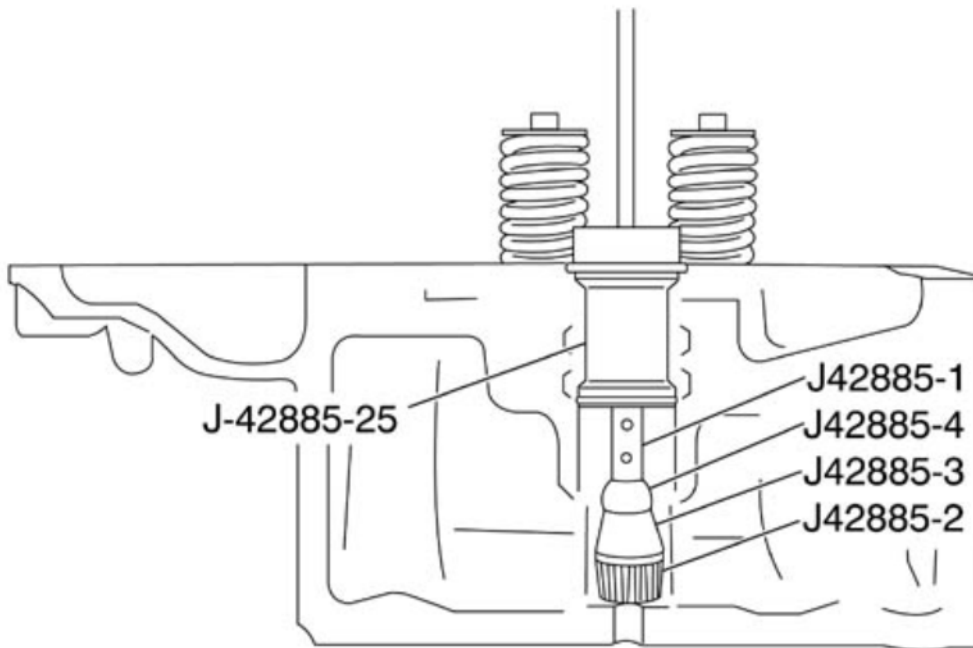

Using the cleaning kit, clean the injector sleeve seat of the cylinder head.

Note: The injector bore sealing tool must be used to prevent dirt from entering the fuel passage.

Note: high speed drill or angle die grinder works best for cleaning with the J42885-2 brush tip.

Special tools: [J42885-1](#), [J42885-2](#), [J42885-3](#), [J42885-4](#), [J-42885-25](#)

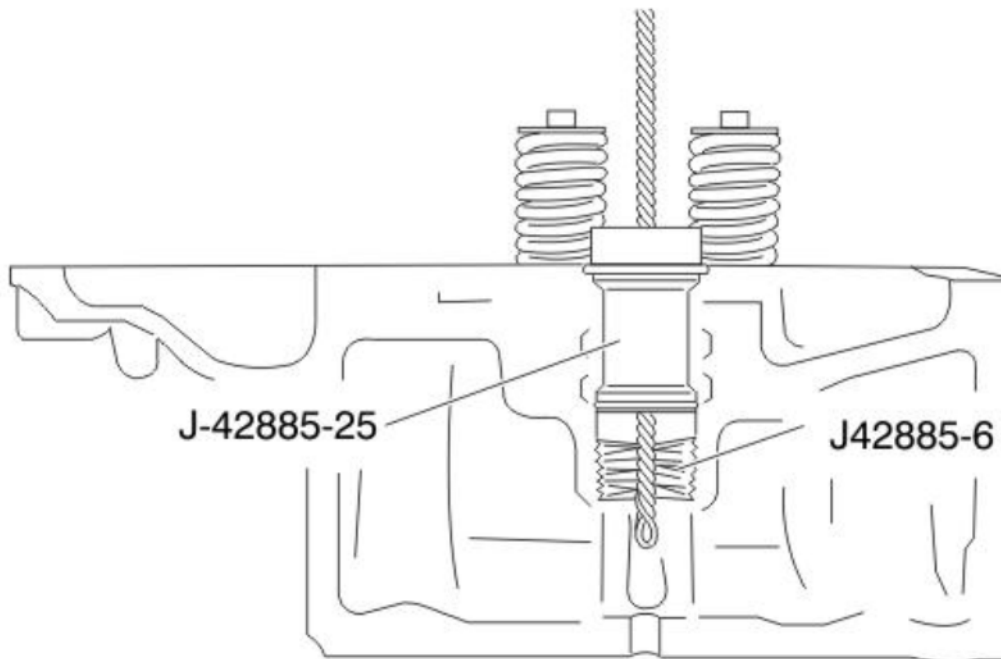

Using the brush, clean the cylinder head injector bore walls for the injector sleeve.

Note: The injector bore sealing tool must be used to prevent debris from entering the fuel passage.

Note: Inspect brush for missing wire bristles and for brush tightness in bore. If several wire bristles are missing or brush fits loose in the bore replace brush.

Special tools: [J42885-6](#), [J42885-25](#)

26

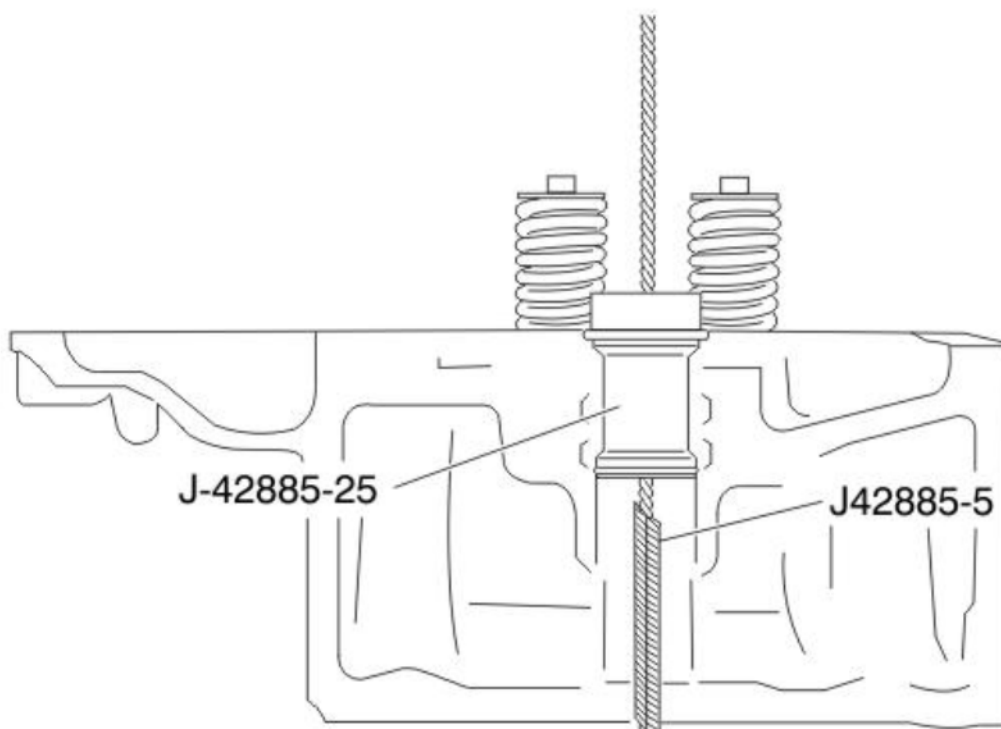

Using the brush, clean the injector sleeve opening in the cylinder head.

Note: The injector bore sealing tool must be used to prevent debris from entering the fuel passage.

Note: Inspect brush for missing wire bristles and for brush tightness in bore. If several wire bristles are missing or brush fits loose in the bore replace brush.

Note: When replacing the copper sleeves, it is important to check that the sleeve bore in the cylinder head is free from any carbon deposits or other residue (i.e., pieces of O-ring, etc.) before installing a new copper sleeve. Reclean if necessary.

Special tools: [J42885-5](#), [J-42885-25](#)

27



Warning

Do not attempt to blow away debris using compressed air. Doing so can result in eye injury.

Using the chip vacuum, remove all debris from the copper sleeve bore.

Note: Injector sleeve seat in cylinder head and the bore for injector sleeve tip must be COMPLETELY clean and dry.

Special tools: [PT2900](#)

28

Remove the injector bore sealing tool from the cylinder head. Using the chip vacuum, remove any remaining debris.

Special tools: [PT2900](#), [J-42885-25](#)

29

Saturate a lint free paper shop towel with brake clean or contact cleaner. Wipe out injector sleeve bore with special attention to the injector sleeve seating area and injector sleeve O-ring sealing area in the cylinder head.

Installation

1

Install the flywheel turning tool. Ensure the piston is at the lowest position in the cylinder. If not, use the flywheel turning tool to place the piston at its lowest position. Confirm the piston is at the lowest position in the cylinder by using a 40 cm (16 inch) piece of straight stiff wire in the injector hole of the cylinder.

Note: This is to ensure that the copper sleeve installation tool does not damage the piston due to tool length.

Note: Ensure the turning tool is well greased before attempting to turn the flywheel.

Special tools: [88800014](#), [9996956](#)

2

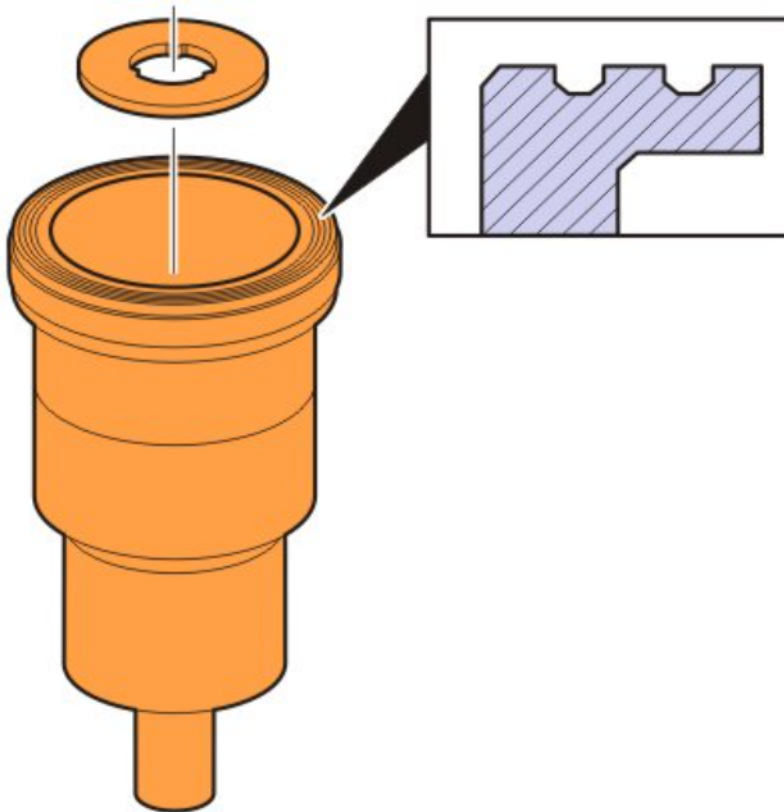

Before installing the copper sleeve, inspect it to ensure that it is the correct part. The correct sleeve is identified by two concentric circular grooves machined into the top surface.

Note: This copper sleeve uses an NBR washer inside the cup as shown. The copper sleeve is smooth at the bottom of the cup. Additionally, if the washer is not used with the copper sleeve, the injector will not seat to inside of the cup.

3

Lubricate a new copper sleeve O-ring with soapy water. Install the O-ring on the copper sleeve and lubricate again with soapy water.

Note: Always use the new O-ring included in the sleeve kit.

 **Caution**

Clean coolant or soapy water is the only approved lubricant for the injector sleeve O-ring. If oil is used it can cause the O-ring to swell and be damaged during installation.

4

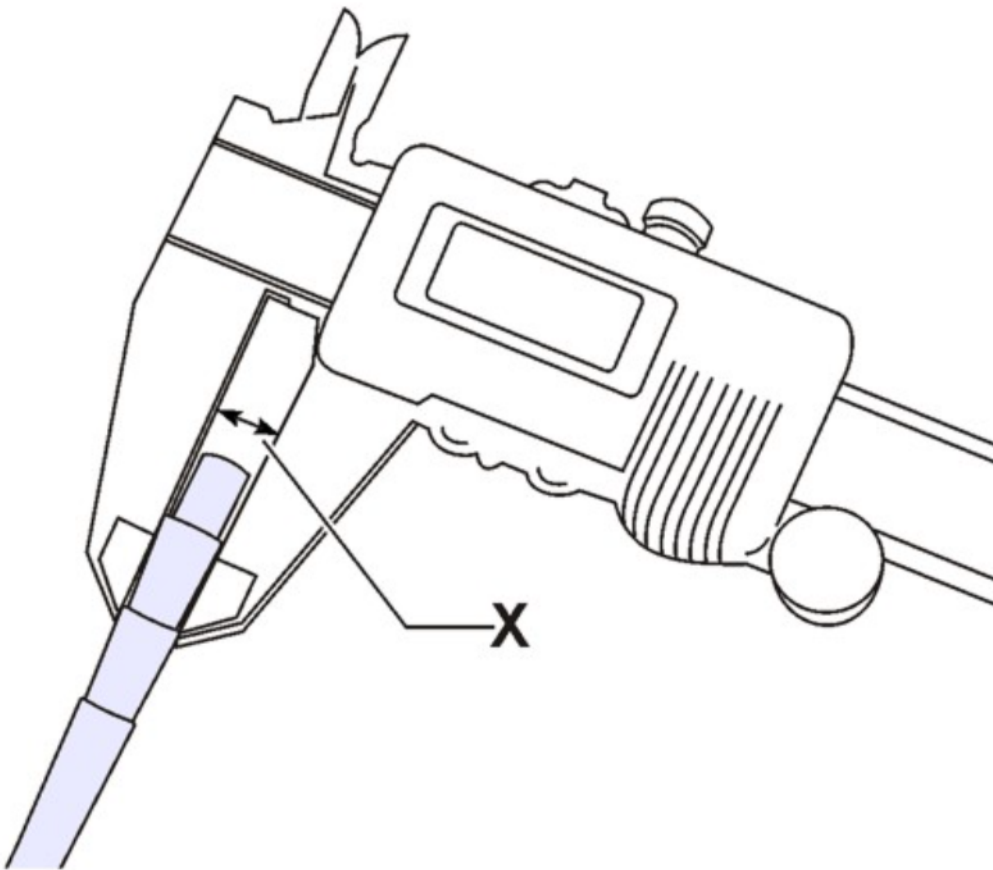

$$X = 7.9 \pm 0.1 \text{ mm}$$

 **Caution**

Failure to use the proper bit can result in the bit breaking off into the cylinder head. These types of failures are not covered by warranty.

Using calipers, measure the swedging bit to make sure that the proper swedging tool is used. Measurement should read 7.9 ± 0.05 mm. Also, verify that the swedging bit has four stages and the length is 120 mm.

Note: Any swedging bit worn past the tolerance must be replaced.

Copyright to this documentation belongs to the Volvo Group. No reproduction, copying, change, amendment or other similar disposal is entitled without prior written consent by the Volvo Group

The information contained herein is current at the time of its original distribution, but is subject to change. The reader is advised that printed copies are uncontrolled.

Note: Swedging bit 88880054 can be ordered as a spare part if the bit is worn or broken.

Special tools: [88880054](#)

5

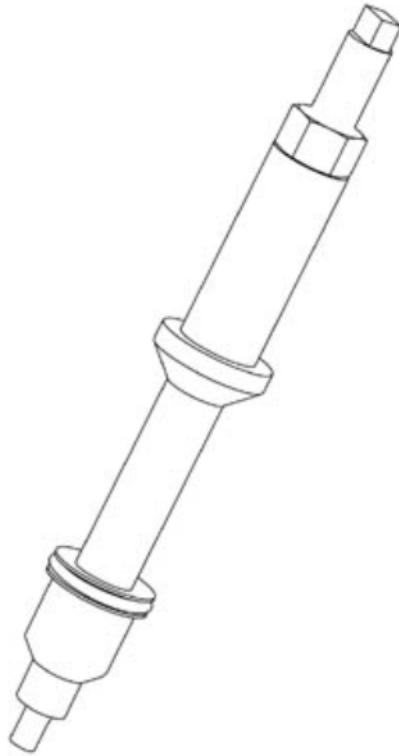

Place the new copper sleeve on the sleeve installation tool.

Note: Do not place the injector nozzle gasket (flat washer) in the copper sleeve, as this will damage the swedging bit.



Caution

Before installing the sleeve on the installation tool, inspect the tool to ensure that it is the correct tool. The correct tool is identified by a bottom surface that is perfectly flat with no machined circular recess. Use of a tool with a machined circular recess on the bottom may result in damage to the copper sleeve.

Note: The copper sleeve installation tool must be smooth on the bottom where it meets the bottom of the copper sleeve cup.

Special tools: [88800196](#)

6

Loosen the swedging bit 180° before installing the tool in the cylinder head.

 **Caution**

Failure to loosen the swedging bit can result in the bit being twisted or broken.

7



Carefully place the sleeve installation tool and new copper sleeve into the engine injector bore of the cylinder head. Carefully move the copper sleeve downward into the injector bore so that the swedging bit is guided into the injector tip bore in the cylinder head. Push downward on the installation tool using hand force to move the copper sleeve downward until it bottoms out on the injector sleeve seat in the bottom of the injector bore. Use the engine injector hold down and bolt to hold the tool in position. To ensure that the copper sleeve is bottomed in the cylinder head, tighten the engine injector hold down bolt to 80 ± 5 Nm (60 ± 4 ft-lb).

 **Caution**

It is very important to clean out injector yoke bolt holes. If fluid is not cleaned out, hydraulic lock can occur when tightening tools or injectors and can result in lack of low clamp load and cylinder head cracking at the injector yoke bolt hole.

8

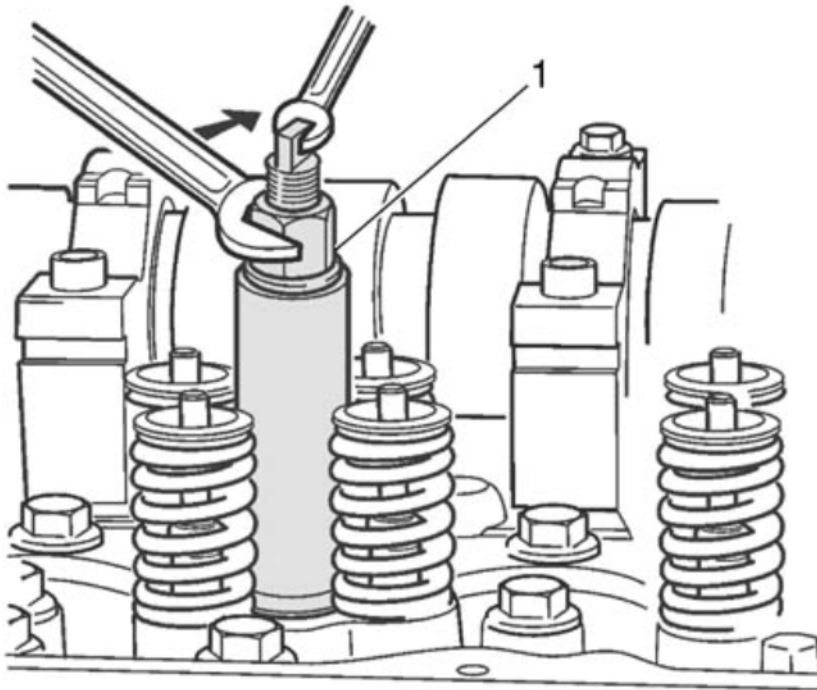

1. Flaring Tool 88800196

Flare the copper sleeve by turning the nut clockwise while holding the spindle until the swedging bit has been pulled completely through the copper sleeve.



Caution

Failure to hold the spindle can result in a twisted or broken swedging bit.

9

Remove sleeve installation tool from the injector bore. If the engine injector is not being installed immediately, install the protective plug into the injector bore to protect it from debris.

Special tools: [9998251](#)

10

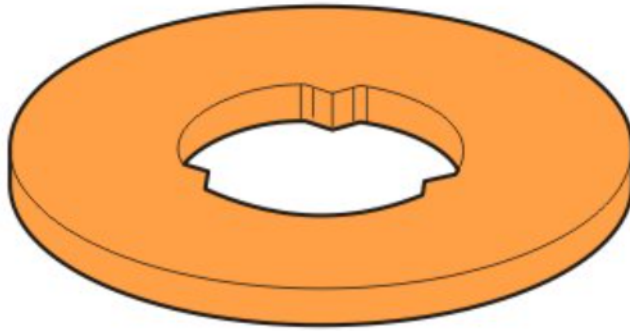

Install the engine injector. Refer to Function Group 237 for procedure.

Note: Ensure the NBR washer shown is installed on the injector before installing the injector into the cylinder head.

11

Install the rocker shaft. Refer to Function Group 214 for procedure.

12

Adjust the valves and engine injectors. Refer to Function Group 214 for procedure.

13

Install the valve cover. Refer to Function Group 211 for procedure.

14

Secure the fuel supply line fitting at the fuel filter housing (loosened earlier to drain fuel from the cylinder head). Clean any fuel that remains around the fitting. Always replace the fuel line seal washers.

15

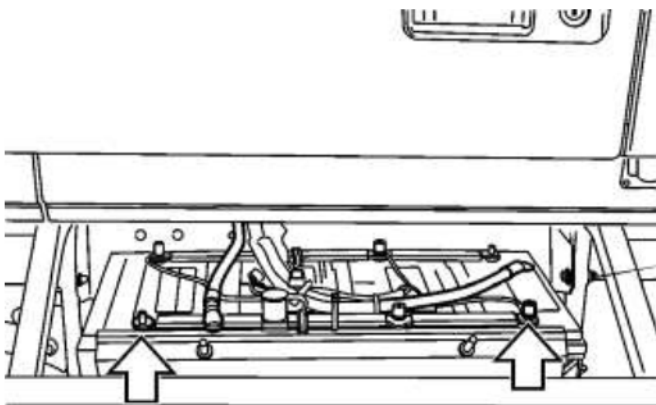

Install all previously removed cables to the ground (negative) battery terminals.

16

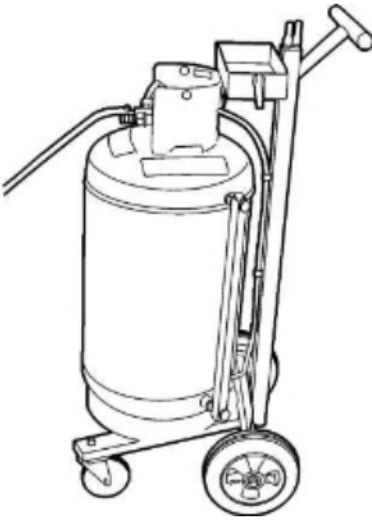

Use the coolant extractor to fill the system with approved coolant per specifications.

Special tools: [DBT2V700](#), [85112740](#)

17

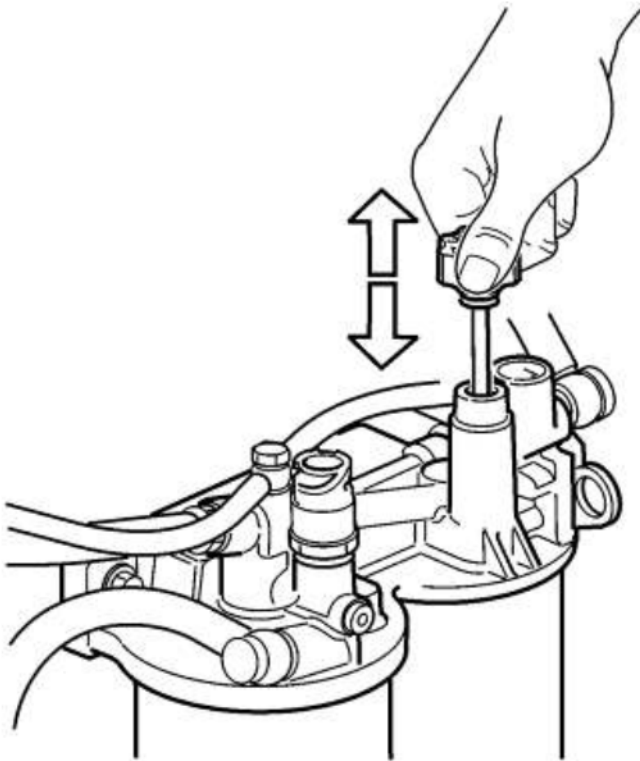

Prime the fuel system by pumping the hand priming pump on the fuel filter housing until resistance is felt indicating that the system is full of fuel.

18

Start the engine and run until the engine clears and runs without stumbling. This procedure may need to be repeated once or twice to get the fuel system completely free of air.

Note: If the engine does not start on the first attempt, prime the fuel system again, and refer to the previous step. Engine priming may need to occur several times in order to get the engine to start.

19

Allow the engine to run at low idle for about 5 minutes. Check for any fuel leaks and correct if necessary.

Copyright to this documentation belongs to the Volvo Group. No reproduction, copying, change, amendment or other similar disposal is entitled without prior written consent by the Volvo Group

The information contained herein is current at the time of its original distribution, but is subject to change. The reader is advised that printed copies are uncontrolled.

Note: The engine speed should not be increased as any air pockets can be forced into the cylinder head which can result in the engine stopping.