

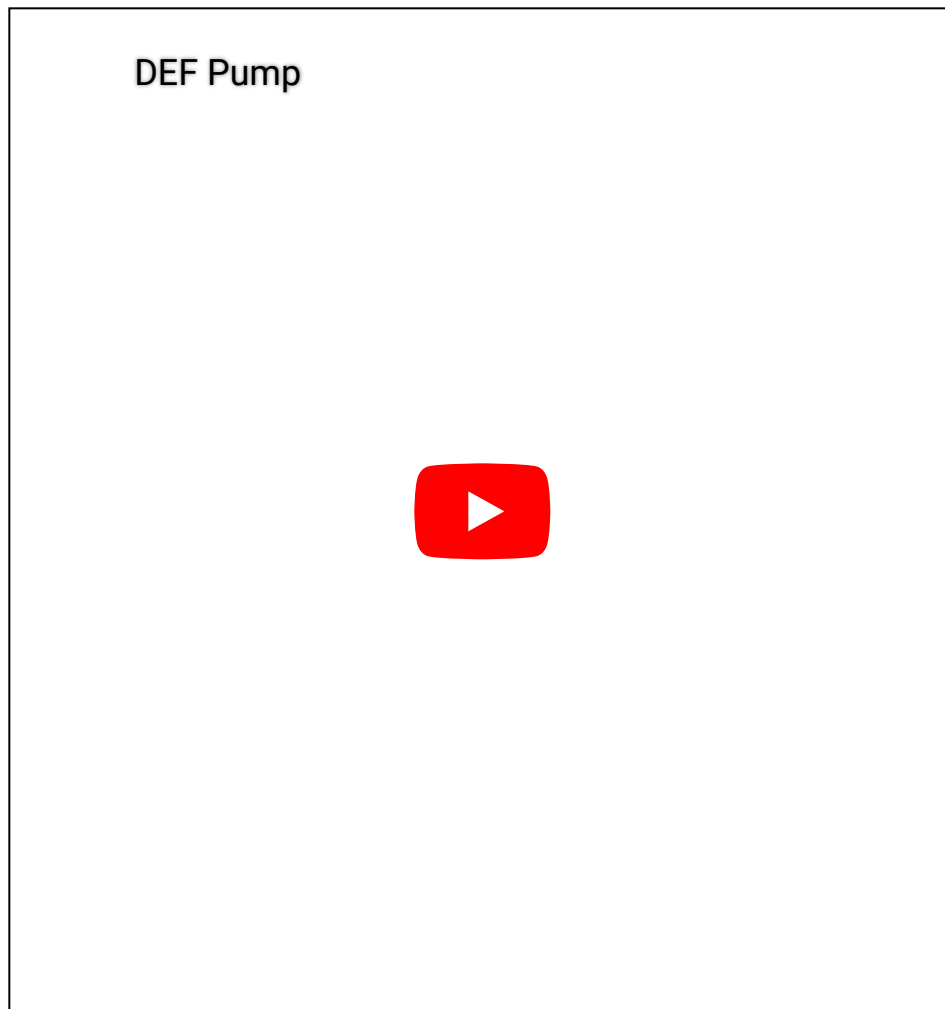

Volvo DEF Pump Troubleshooting Guide - US10+OBD13 And Newer Emissions



Component Overview



The Diesel Exhaust Fluid (DEF) Pump's function is to build and regulate the DEF systems pressure that is supplied to the dosing valve. The DEF Pump is a multi-unit component that consists of:

- Mechanical pump
- Reverting valve
- Pressure sensor
- Main filter
- Fluid connectors (2 coolant & 3 DEF)
- Electrical connector



The DEF Pump is controlled by the After-Treatment Control Module

(ACM). On every key cycle, the sensors and actuators in the DEF dosing system perform a self-check for proper operation. When the truck is turned off, the ACM uses a temperature based delayed reverting/draining strategy to pump the DEF back into the tank.

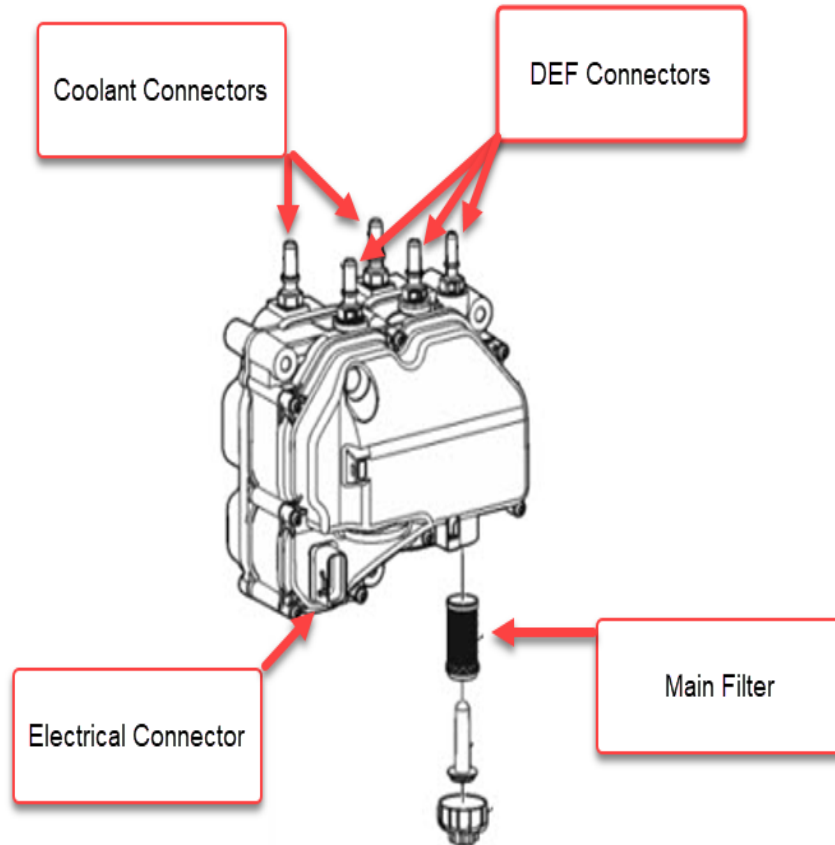

The primary failure mode of the DEF Pump is:

- Leak - externally leaking fluid
- Internal Failure - which will generate a specific DTC

Diagnose and Repair

NOTE: a large amount of DEF Pumps returned through warranty have been tested and determined to have No Fault Found. It is extremely important to not replace the DEF Pump unnecessarily but to determine the cause of the failure.

Leaking DEF

Not all leaks at the DEF pump require replacement of the pump assembly. It is imperative to determine the location of the leak.

1. Clean the suspected area using a suitable solvent.
2. Run PTT Option **2589-08-03-05 Subtest A** to pressurize the system.
3. Inspect the affected area to determine the location of the leak using the table below.

Location of Leak	Direction
Fluid Connectors	Repair or Replace fitting and/or hose
Filter Assembly	Replace Filter Assembly
Electrical Connector	Replace DEF Pump
Pump splitting	Replace DEF Pump

Internal Failure of the Pump

All internal pump failures will generate a specific Diagnostic Trouble Code (DTC)

Perform a DTC Readout using Premium Tech Tool. Review the tables below to determine which category the Fault Code currently being diagnosed falls under. Proceed according to the directions for the appropriate section.

Under Pressure Faults

DTC	Description
P20E8-92	Reductant Pressure Too Low, Incorrect Operation
P202D-00	Aftertreatment Reagent Pressure Leakage
P20BA-00	Reductant Heater A control Performance

Directions:

1. Inspect def tank for frozen fluid, debris, or low level.
2. Disconnect the supple line at the DEF Pump.

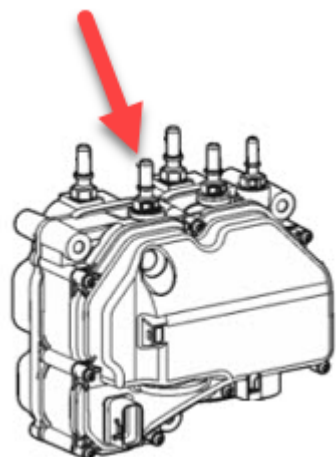

3. Connect a clear 3/8" (inner diameter) hose to the fitting and place the other end of the hose into the DEF Tank.

- **Note:** This will require removal of DEF Tank Filler Neck Insert (Impact **2589-03-02-42**).

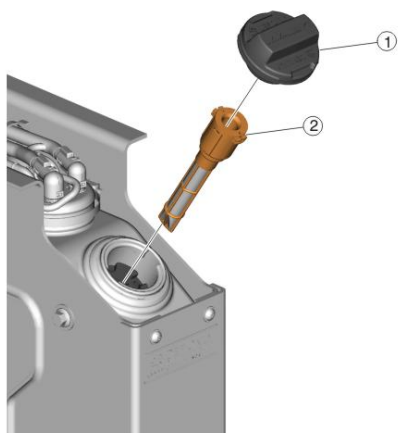

4. Run Pressure Build Up Operation in PTT **2589-08-03-05 Selection A**. Ensure the DEF Pump is running (audible noise) and allow to run for at least 5 minutes.

5. Evaluate results:

- **If the system is not able to build pressure:** Replace the inlet fitting (which contains a screen, which could be blocked). Re-run evaluate. If the pump is still not able to build pressure, Replace the DEF Pump in accordance with Impact operation **2581-03-02-01** .

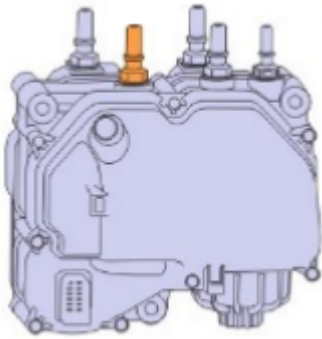

• **If the system is able to build pressure:** The pump is not the issue. Further diagnosis is needed for the supply side of the system. Inspect the below components and repair as necessary:

- **DEF Tank Vent** - make sure the vent is clean and free of debris.

○ **NOTE:** Do NOT blow air through the line, as this will likely introduce debris into the DEF Tank.

- **Lines Blockage from DEF Tank to Pump.**

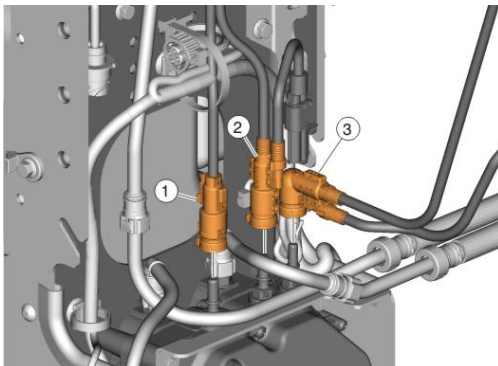
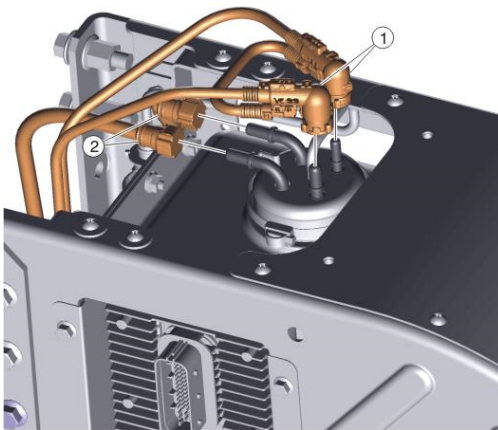

- **Blocked/damaged Tank Screen or pickup tube.**

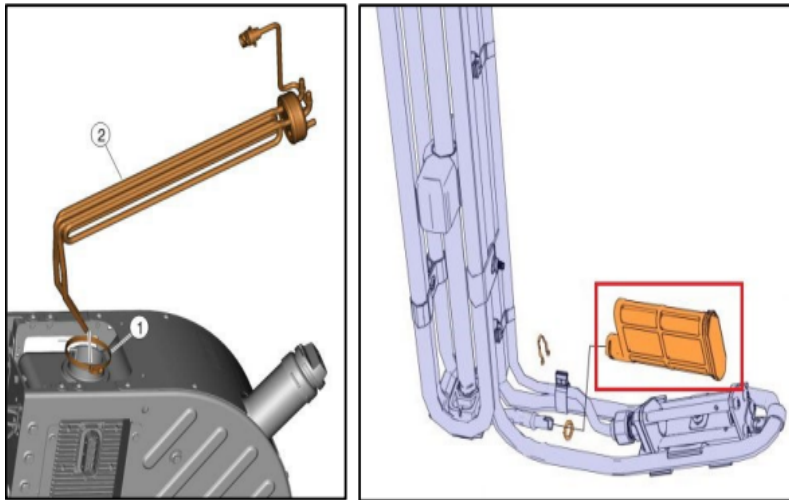

Over Pressure Faults - only diagnose active DTCs.

DTC	Description
P208B-00	Reductant Pump "A" Control Performance/Stuck Off
P10CE-97	Reductant Return No Flow Detected
P20A1-07	Aftertreatment Reagent Direction Valve Mechanical Problem

Directions:

1. Inspect def tank for frozen fluid or debris.
2. Replace return line fitting (this fitting contains a return orifice).

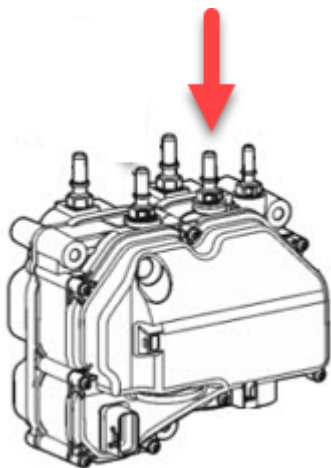

4. Evaluate the results

- **If the DEF Pump builds pressure and does not shut down for 5 minutes:** Clear the faults and release the vehicle.
- **If the DEF Pump over pressures and stops running (DTC will log again):**
 - a. Check return line (from DEF Pump to DEF Tank) for blockage and replace as necessary.
 - b. Re-run the evaluation. If the pump continues to overpressure, replace the pump in accordance with Impact operation **2581-03-02-01**.

Electrical Faults - only diagnose active or confirmed DTCs

DTC	Description
P20A0-13	Reductant Purge Control Valve, Open Circuit
P10AD-13	Reductant Pump "A" Control Low Side, Open Circuit
P204A-13	Reductant Pressure Sensor, Open Circuit
P208A-13	Reductant Pump "A" Control, Open Circuit
P208C-00	Aftertreatment Reagent Pump Control Short Circuit Low
P20A2-00	Aftertreatment Reagent Direction Valve Short Circuit Low
P204C-00	Aftertreatment Reagent Pressure Sensor Circuit Low
P10AF-00	Reductant Pump "A" Control Low Side Circuit High
P204B-64	Aftertreatment Reagent Pump Orifice Blocked
P10AE-00	Reductant Pump "A" Control Low Side Circuit Low
P208D-00	Aftertreatment Reagent Pump Control Short Circuit High
P20A3-00	Aftertreatment Reagent Direction Valve Short Circuit High

Directions: all of the above codes will cause the DEF Pump to discontinue operation until code is corrected. Inspect electrical circuits using PTT Diagnostics to identify the electrical issue.

NOTE: For trucks operating in a dirty or harsh environment and experiencing repeat DEF Pump Failures see Technical Service Bulletin (TSB) **Aftertreatment Diesel Exhaust Fluid (DEF) Tank Vent Filter, New Installation.**

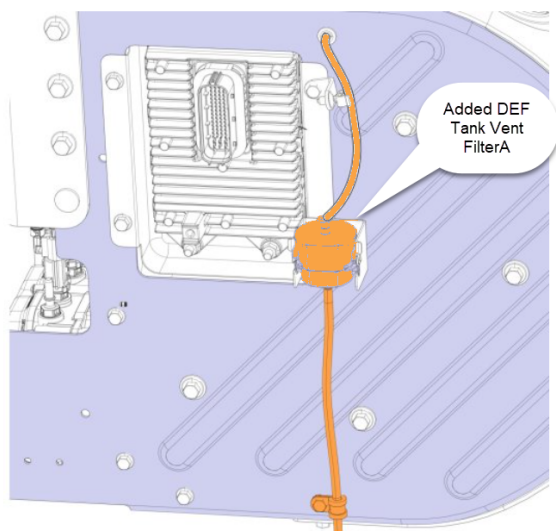

Rules for Replacement

Warranty will only cover replacement of the DEF Pump if:

- Leak is identified as unreparable (leaks at fittings or main filter are repairable), these pumps may require parts returned for analysis.
- Fault codes in the Yellow sections above is active or confirmed.

In addition, if the DEF Pump is being replaced. Maintenance records will be required showing the cleaning of the DEF Tank and Filter Change have been properly maintained and are not the root cause of the failure.

Refer to Service At a Glance (SAG) found in the Trucks Dealer Portal under the Information tab - Service - Service literature for replacement and cleaning intervals of the DEF Tank & Filters.

Standard Diagnostic Time 1.0 hrs

Diagnostic Trouble Codes With DEF/Urea in the Description

Direction/Repair: DO NOT REPLACE the DEF Pump for these codes.

Diagnostics should be performed using PTT Diagnostics and the comment

Live UI in the table below.

DTC	Description	Probable Source
P2042-01	Reductant Temperature Sensor, Electrical Failure	Temperature - Check wiring harness CBR-2015
P21CA-00	Reductant Control Module Supply Voltage	Check ACM Power Supply CBR-2040

 Tags

[p2042-01](#) [p20a3-00](#) [p208d-00](#) [p10ae-00](#)
[def pump](#) [def tank](#) [def filter](#) [p21ca-00](#)
[p204b-64](#) [p10af-00](#) [p204c-00](#) [p20a2-00](#)
[p208c-00](#) [p208a-13](#) [p10ce-97](#) [p20a1-07](#)
[p20e8-92](#) [p202d-00](#) [p20ba-00](#) [p204a-13](#)
[p10ad-13](#) [p20a0-13](#) [p208b-00](#) [unlocking uptime](#)

Related links and attachments

[KC-2165 2589-08-03-05 IMG 3](#)

[KC-2165 2589-08-03-05 IMG 2](#)

[KC-2165 2589-08-03-05 IMG 1](#)

[KC-2165 2589-03-02-42](#)

[KC-2165 2581-03-02-01](#)



Feedback

[Give feedback](#)

to help improve the content of this article