

ATTENTION:

- GENERAL MANAGER
- PARTS MANAGER
- CLAIMS PERSONNEL
- SERVICE MANAGER

IMPORTANT - All Service Personnel Should Read and Initial in the boxes provided, right.

© 2022 Subaru of America, Inc. All rights reserved.



QUALITY DRIVEN® SERVICE

SERVICE PROGRAM BULLETIN

APPLICABILITY: 2023 MY Legacy
2023 MY Outback

NUMBER: WRI-22

DATE: 10/19/22

SUBJECT: Telematics DCM Replacement

In the interest of customer satisfaction, Subaru of America, Inc. (Subaru) is initiating this service program for certain 2023 model year Legacy and Outback vehicles equipped with STARLINK® In-Vehicle Technology.

REASON FOR THIS SERVICE PROGRAM

The APN (Access Point Name) profile within the telematics data communications module (DCM) software is not applicable for U.S. vehicles. When the DCM cannot connect to the 4G VoLTE network for in-vehicle voice calls, the DCM tries to connect to the 3G network. As a result, since the 3G network is no longer available in the U.S., the attempted call will fail.

In-vehicle voice calling includes Automatic Collision Notification (ACN), SOS Emergency Assistance, and Enhanced Roadside Assistance.

DESCRIPTION OF THE REPAIR

Subaru retailers will inspect and, if necessary, replace the telematics DCM at no cost to the customer.

AFFECTED VEHICLES

The number of U.S. vehicles included in this service program is 21,763.

Model Year	Carlines	Production date range
2023	Legacy and Outback	July 22, 2022 – September 29, 2022

Not all vehicles in the production date range listed above may be included in this service program. Coverage for all affected vehicles must be confirmed by using the Vehicle Coverage Inquiry function on subarunet.com.

CAUTION: VEHICLE SERVICING PERFORMED BY UNTRAINED PERSONS COULD RESULT IN SERIOUS INJURY TO THOSE PERSONS OR TO OTHERS.

Subaru Service Bulletins are intended for use by professional technicians ONLY. They are written to inform those technicians of conditions that may occur in some vehicles, or to provide information that could assist in the proper servicing of the vehicle. Properly trained technicians have the equipment, tools, safety instructions, and know-how to do the job correctly and safely. If a condition is described, DO NOT assume that this Service Bulletin applies to your vehicle, or that your vehicle will have that condition.

Subaru of America, Inc. is ISO 14001 Compliant

ISO 14001 is the international standard for excellence in Environmental Management Systems. Please recycle or dispose of automotive products in a manner that is friendly to our environment and in accordance with all local, state and federal laws and regulations.

Continued...

RETAILER RESPONSIBILITY

Any vehicles listed in any recall or campaign that are in retailer stock must be:

- Immediately identified
- Tagged or otherwise marked to prevent their delivery or use prior to repair
- Repaired in accordance with the repair procedures outlined in the bulletin

Retailers are to promptly perform the applicable service procedures, to correct all affected vehicles in their inventory (new, used, demo & SSLP). Additionally, whenever a vehicle subject to this service program is taken into inventory or in for service, necessary steps should be taken to ensure the repair has been made before selling or releasing the vehicle.

OWNER NOTIFICATION

Owners will be notified by first class mail. Retailers will be advised when owner notification is scheduled.

PART INFORMATION:

Part Description	Part Number
Data Control Module (Standard Audio)	86222AN20A
Data Control Module (Premium Audio)	86222AN21A

These parts can ONLY be used for vehicles affected by WRI-22. Retailer ordering does not apply. ALL retailers will be force shipped.

NOTE: The backup battery is included with the modules listed above.

SERVICE PROCEDURE / INFORMATION:

Verification Procedure:

Verification of i-Button Process:

Vehicles unable to perform a successful call will require DCM replacement. If this behavior is duplicated, proceed to the DCM replacement procedure outlined in this bulletin. If this behavior continues after DCM replacement has been performed, further diagnostics will be required.

The link below provides an **EXAMPLE** of an unsuccessful STARLINK® call attempt.

[iButton Failure](#)

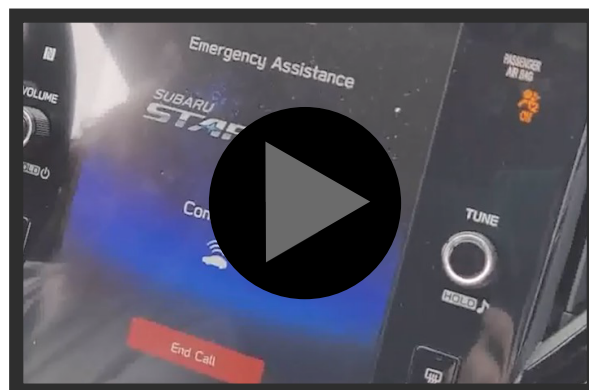

Continued...

DCM REMOVAL AND INSPECTION PROCEDURE:

STEP 1: Apply the parking brake

STEP 2: Refer to the applicable Service Manual and review: General Description > Repair Contents > Action required before & after Battery Disconnect. Additionally, record any stored seat position(s) before proceeding. Relearn any seat position memory after work is complete. If the power rear gate (PRG) height has been customized, that position must also be noted and relearned. CAREFULLY disconnect the ground terminal from the battery sensor. Once disconnected, wait at least 60 seconds before starting any further procedures.

NOTE: A suitable plastic trim tool will be required for the following procedures.

STEP 3: Release the four mounting clips securing the driver side instrument panel side cover. Once released, remove the cover.

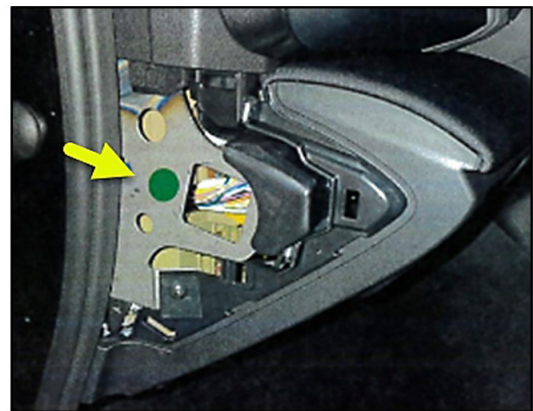
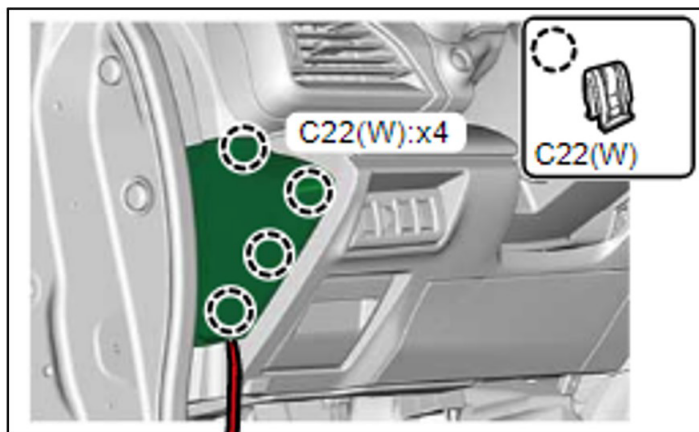

NOTE: If a **GREEN** sticker is present, STOP. This vehicle has the latest DCM, and is not affected by the WRI-22 service program.

STEP 4: Release the three mounting clips securing the driver side front under cover. Once released, remove the cover.

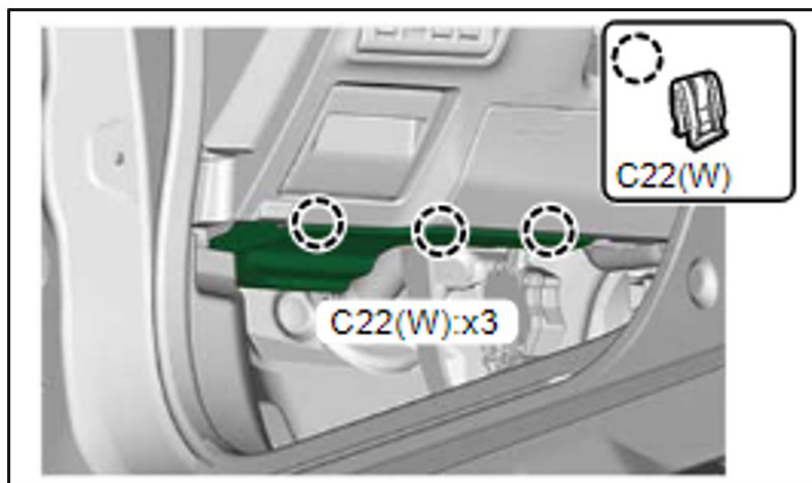

Continued...

STEP 5: Remove the two mounting screws securing the lower driver cover. Once removed, pull the cover in a straight direction toward the rear of the vehicle to release the mounting clips.

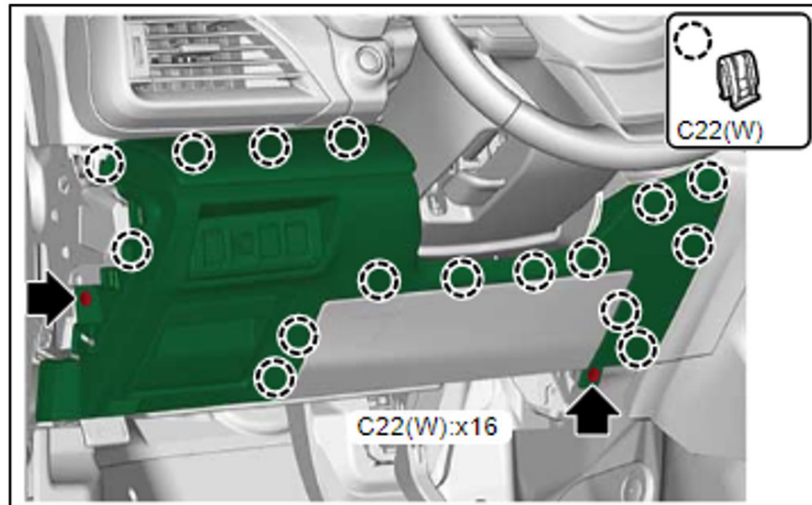

CAUTION: When removing the lower driver cover, **ALWAYS** pull the cover in a straight direction. Pulling in a lateral or upward direction may cause damage to the lower driver cover.



CAREFULLY disconnect all electrical connections. Remove the lower driver cover from the vehicle.

STEP 6: Release the steering column lock, adjust the steering wheel to the lowest level and pull it outward to its full extent. Lock the steering in this position. Using a small screwdriver, remove the two mounting screws for the combination meter trim panel. Release the four mounting clips securing the panel. The panel can then be removed.

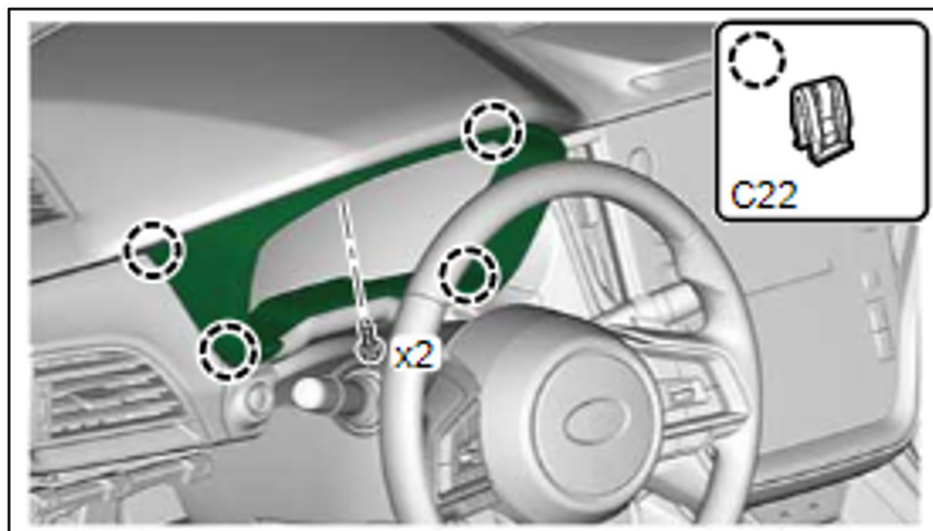

Continued...

STEP 7: Release the 7 mounting clips from the driver monitoring unit. Once released, pull the unit toward the rear of the vehicle in a straight direction. Release the electrical connection and remove the unit from the vehicle.

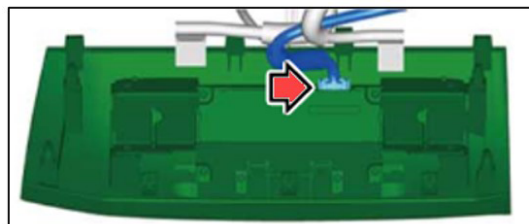
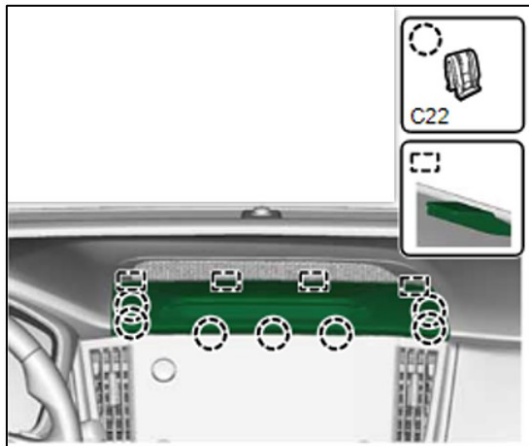

STEP 8: Remove the rubber grip mat from the center tray. Using a screwdriver or suitable tool, release the shift lock and shift the lever into the neutral position.

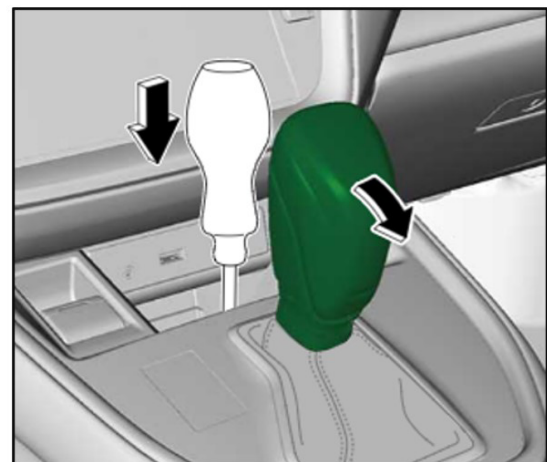
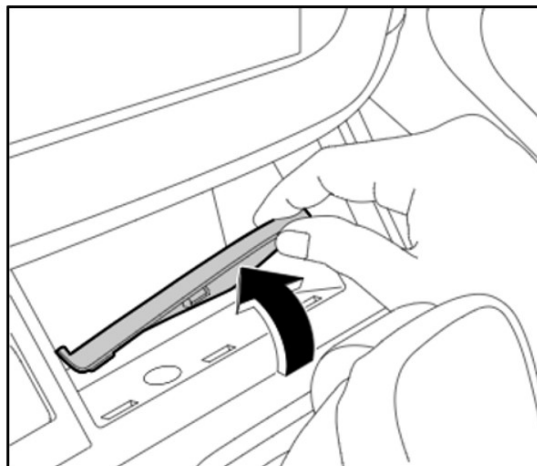

Continued...

STEP 9: Detach clamp (A) from the shift knob. Release clip (B) from the shift knob and remove the knob from the lever. ALWAYS maintain proper shift rod alignment when reinstalling (detailed information can be found in the September 2021 TechTIPS article).

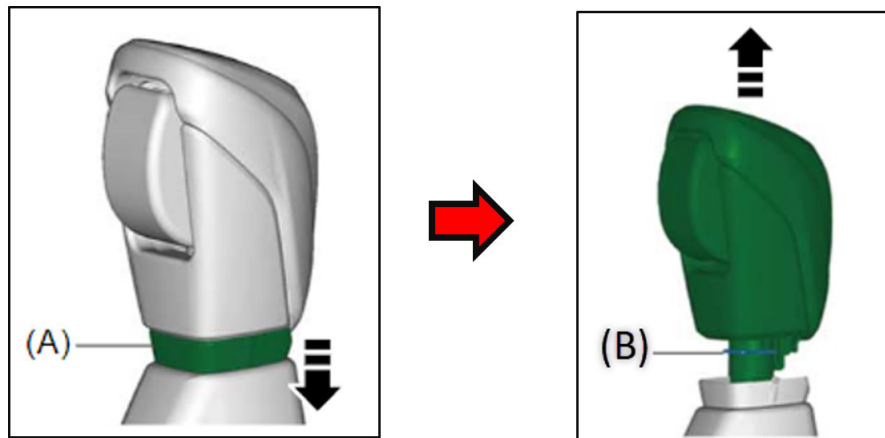

STEP 10: Release the center console cover mounting clips and remove the cover with the shift boot/bezel attached.

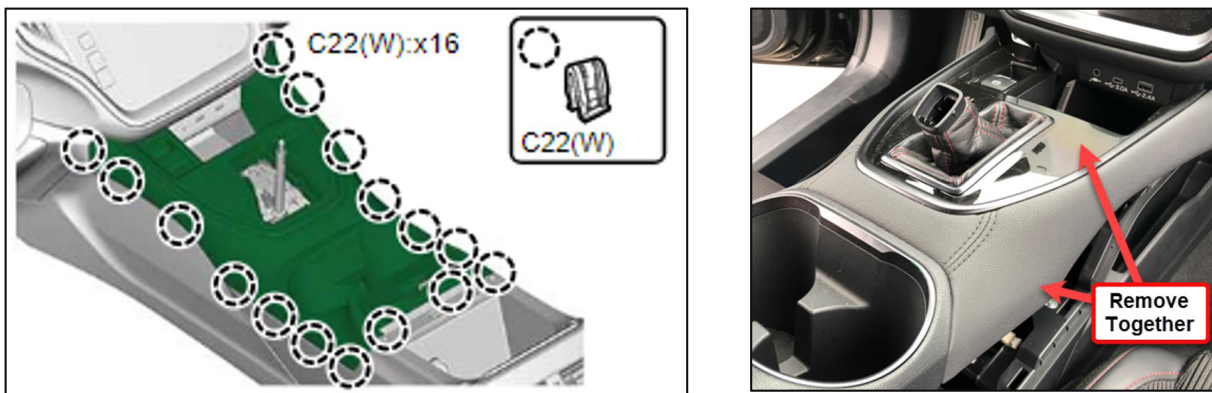

STEP 11: Release the mid passenger ornament panel mounting clips and remove the panel.

NOTE: Vehicles equipped with push button start will require the push button ignition switch to be disconnected prior to removal.



Continued...

STEP 12: Remove the four screws securing the Center Information Display (CID) assembly. Release the mounting clips and CAREFULLY pull the assembly out far enough to disconnect the electrical connections. Once all the connectors are disconnected, the CID assembly can be removed. Use caution when handling, the display can be easily scratched.

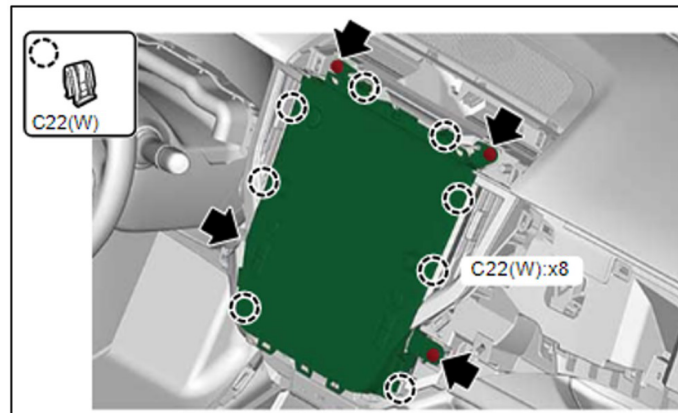

STEP 13: Place the CID assembly on a secure flat surface. Disconnect the Data Communication Module (DCM) cable.

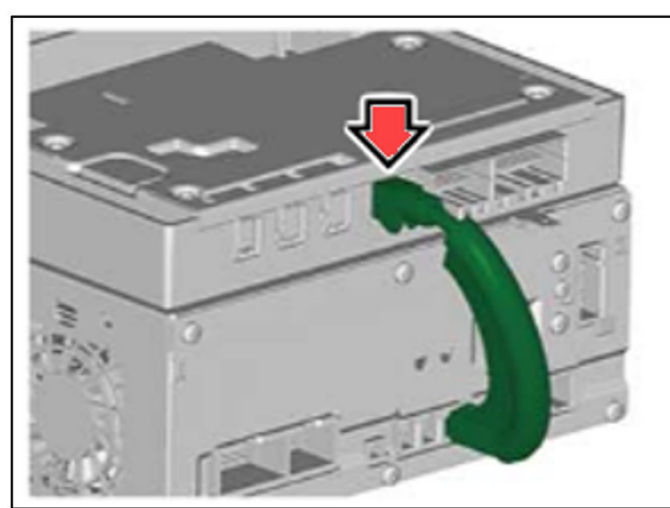

STEP 14: Remove the four DCM mounting screws located on the left and right side. The DCM can then be removed.

CAUTION: DO NOT apply any impact to the CID assembly or DCM during this process.

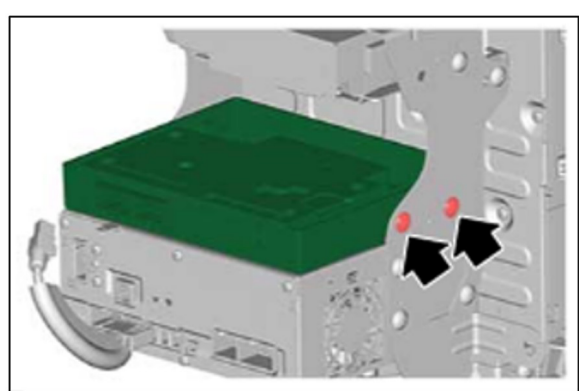
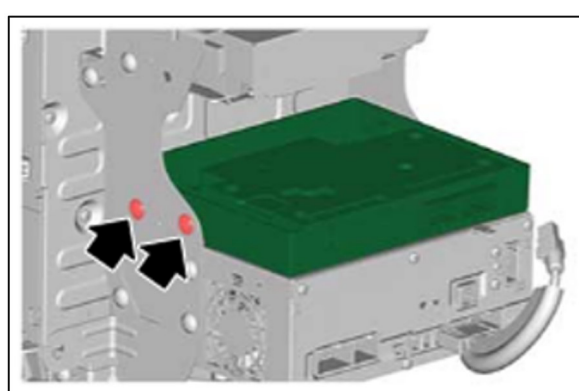

Continued...

- **STEP 15:** Remove and properly recycle the back-up battery from the original DCM.

NOTE: If a **GREEN** sticker is present, STOP. This vehicle has the latest DCM, and is not affected by the WRI-22 service program.



STEP 16: Replace the DCM. Reinstall all parts in the reverse order of removal.

IMPORTANT NOTE: Whenever reconnecting the ground cable terminal to the battery sensor, torque to 7.5Nm (5.5ft.-lbs. or 66inch-lbs.) while supporting the sensor with the other hand as outlined in the applicable Service Manual under: [STARTING/CHARGING SYSTEMS > Battery Sensor](#).

STEP 17: Perform registration of the immobilizer as per the “Type G” or “Type H” section of the [Registration Manual for Immobilizer](#). Information is also available in **TSB 15-246-19R**.

NOTE: Type G = Key Start models. Type H = Keyless Access with Push Button Start models.

STEP 18: Perform the “Comm Check” procedure and confirm the LED illumination status.

- A. Disconnect Subaru Select Monitor (SSM) if connected to the vehicle.
- B. Press and hold the i-button for two seconds.
- C. Confirm the LED located on the telematics i-button illuminates and observe the result.

NOTE: When the subscription is complete, the telematics system will automatically activate during the “Comm Check.” The LED blinks GREEN & RED alternately during activation. When finished the LED will display one of the five results shown below.

Continued...

LED	Status	Situation
Solid Green		System is normal. A subscription to the SUBARU STARLINK service has been established*.
Solid Red		A system malfunction has occurred. Refer to the Troubleshooting - page 39.
Flashing Green or Red		SUBARU STARLINK service is currently communicating (e.g. Voice call, Stolen Vehicle Recovery, etc.).
No Light		A subscription to the SUBARU STARLINK service has not been established. Refer to the Troubleshooting - page 39.
Solid Green and Red		SUBARU STARLINK service is currently having communication problems.

- D. After reconnecting the Subaru Select Monitor (SSM), read the “Subscription Status” data monitor item in the Telematics system. Verify the stored VIN. Verify the subscription displays “Subscribed” or “Unsubscribed.” Verify the PID matches the results of the initial “Comm Check.”

Item	Value
Diagnostic Alert Active	TRUE
Power Source Status	DCM Curr...
Subscription Status	Subscribed
Battery Voltage	11.7410
Stored VIN	4S4BTGPD...
Timestamp at Time of Button Push(1):Date	-

CAUTION: In rare cases, the data monitor item may display “Comm Check” or “Factory Mode.” This indicates the initial “Comm Check” procedure was unsuccessful. Check the radio wave environment and confirm no DTCs have been stored within the telematics system. Turn the ignition switch to the “OFF” position and confirm the LED turns off. Restart the “Comm Check” procedure and continue.

After successful completion of the “Comm Check” procedure, continue to the following applicable Repair Confirmation Processes.

Continued...

REPAIR CONFIRMATION PROCEDURES:

Repair Confirmation Process for the i-Button on vehicles subscribed to STARLINK® Safety Plus.

NOTE: Always confirm the vehicle is subscribed to STARLINK® Safety Plus or higher. This can be confirmed by the customer or by a STARLINK® Call Center Operator.

1. Confirm all electrical accessories, headlamps, HVAC, etc. are in the off position.
2. Confirm the gear selector is in the “Park” position. Apply the Electronic Parking Brake (EPB).
3. Switch the ignition switch to the “ON” position (engine off).
4. Confirm all doors (including the rear gate if equipped) are closed and locked.
5. Press the i-button and wait for the STARLINK® Operator to respond. Verify your retailer credentials and inform the Operator of test work being performed on the telematics system.
6. Request the Operator to report the last 8 characters of the VIN along with the vehicle location. Verify the information given is accurate.

Repair Confirmation Process for the Remote Service Operation on vehicles subscribed to STARLINK® Safety Plus and Security Plus.

NOTE: Always confirm the vehicle is equipped with a Gen 2 head unit and is subscribed to STARLINK® Security Plus. This can be confirmed by the customer or by a STARLINK® Safety Call Center Operator.

1. Confirm all electrical accessories, headlamps, HVAC, etc. are in the off position.
2. Confirm the gear selector is in the “Park” position. Apply the Electronic Parking Brake (EPB).
3. Switch the ignition switch to the “ON” position (engine off).
4. Confirm all doors (including the rear gate if equipped) are closed and locked.
5. Press the i-button and wait for the STARLINK® Operator to respond. Verify your retailer credentials, the last 8 characters of the VIN, and the vehicle location.
6. Request and test remote door unlock command to be sent to the vehicle and verify the successful or unsuccessful result of this request.

Continued...

Repair Confirmation of DCM replacement for vehicles without STARLINK® subscription.

1. Verify both SOS LEDs are NOT illuminated.
2. Using SSM, read the data monitors of the Telematics System.
3. Using Subaru Select Monitor (SSM), read the “Subscription Status” and the “Stored VIN” data monitor items in the Telematics system. Verify the subscription displays “Unsubscribed” and the VIN is correct.

Item	Value
Diagnostic Alert Active	TRUE
Power Source Status	DCM Curr...
Subscription Status	Unsubscribed
Battery Voltage	11.7410
Stored VIN	4S4BTGPD...
Timestamp at Time of Button Push(1):Date	-

CLAIM REIMBURSEMENT AND ENTRY PROCEDURES:

Credit to perform this recall will be based on properly completed repair order information. Retailers may submit claims through Subarunet.com.

Labor Description	Labor Operation #	Labor Time	Fail Code
DCM Replacement R&R	A065-000	0.6	WRI-22

Part Number	Applicability	Description	Order Quantity
MSA6P1302	All Models	Campaign Completion Labels (contains one sheet of 20 labels)	1

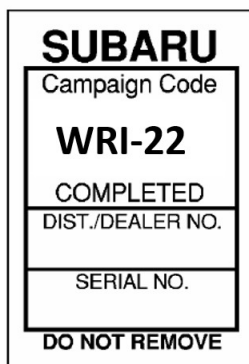



IMPORTANT REMINDERS:

- SOA strongly discourages the printing and/or local storage of service information as previously released information and electronic publications may be updated at any time.
- Always check for any open recalls or campaigns anytime a vehicle is in for servicing.
- Always refer to STIS for the latest service information before performing any repairs.

Continued...

Appendix

Normal Conditions:

LED status	Subscription contents	Contents
VN-AJ  ET-11474	Without subscription of SUBARU STARLINK	Comm Check and communication establishment completed
VN-AJ  ET-11475	With subscription of SUBARU STARLINK	

Malfunctioning Condition:

LED status	Cause	Corrective action
VN-AJ  ET-11476	Comm Check cannot be performed normally due to poor radio wave environment.	Perform Comm Check again in a location with good radio wave environment. Note: Radio wave reception condition can be checked using Subaru Select Monitor. 1. Turn the ignition switch from OFF to ON. 2. Press and hold the i-button for 2 seconds or more to set to Factory mode, and press and hold the i-button for 2 seconds or more again to perform Comm Check.
	Comm Check cannot be performed normally as the server has a malfunction.	Call an authorized workshop and check that the serial number, IMEI number, and chassis number are correct.