

TECHNICAL BULLETIN
K196NAS1
06 OCT 2014



© Jaguar Land Rover North America, LLC

NOTE: The information in Technical Bulletins is intended for use by trained, professional Technicians with the knowledge, tools, and equipment required to do the job properly and safely. It informs these Technicians of conditions that may occur on some vehicles, or provides information that could assist in proper vehicle service. The procedures should not be performed by 'do-it-yourselfers'. If you are not a Retailer, do not assume that a condition described affects your vehicle. Contact an authorized Jaguar service facility to determine whether this bulletin applies to a specific vehicle.

SECTION: 501-10

Service Action: Seatback Business Tray

AFFECTED VEHICLE RANGE:

XJ Range (X351)

Model Year: 2012-2013
VIN: V28345-V58569

MARKETS:

NAS

CONDITION SUMMARY:

Situation: A potential issue has been identified on a number of 2012-2013 model year XJ (X351) vehicles where the seatback business tray will not lock.

Action: Retailers are required to **HOLD** only affected vehicles that are within your control and refrain from releasing the vehicles for new or used vehicle sale pending completion of the rework action detailed in this Technical Bulletin. Unsold vehicles should have this performed as part of the Pre-Delivery Inspection (PDI) process but **must** have it completed prior to vehicle handover to the customer. Affected vehicles already in the hands of customers should be updated at the next available opportunity.

PARTS:



NOTE: * when ordering parts, order only the expected percentage demand of parts identified

DESCRIPTION	PART No. / SUNDRY CODE	QTY. / VALUE	EXPECTED % of VEHICLES REQUIRING PARTS*
Spacer	C2D38514	2	100
Tray latch - Bordeaux	C2D16173CJB	2	100
Tray latch - Cashew	C2D13489APH	2	100
Tray latch - Dove	C2C22254LHJ	2	100
Tray latch - Ebony	C2D16173PVJ	2	100
Tray latch - London Tan	C2D13489APJ	2	100
Tray latch - Navy	C2D13489JMN	2	100
Tray latch - Ivory	C2D13489NUG	2	100
Tray latch - Parchment	C2D16173VAE	2	100

SPECIAL TOOLS:

Refer to Workshop Manual / Service Instruction for any required tools

WARRANTY:

NOTE: Check DDW to ensure that a vehicle is affected by this program prior to undertaking any rework action. Repair procedures are under constant review, and therefore times / prices are subject to change; those quoted here must be taken as guidance only. Refer to TOPIX to obtain the latest repair time. At the time of confirming a booking for vehicle repair, ensure that all outstanding Service Actions are identified to ensure the correct parts are available and adequate workshop time is allocated for repairs to be completed at one visit.

Warranty claims must be submitted quoting Program Code '**K196**' together with the relevant Option Code from the table. The SRO and part information listed have been included for information only. The Option Code(s) that allows for the drive in / drive out allowance may only be claimed if the vehicle is brought into the workshop for this action alone to be undertaken.

This program is valid for a limited time only. Warranty claims with a repair date prior to the **31 May 2016** closure date must be submitted for payment within 30 calendar days of completion of the repair.

PROGRAM CODE	OPTION CODE	DESCRIPTION	SRO	TIME (HOURS)	PARTS / SUNDRY CODE	QTY. / VALUE
K196	B	Check for cracks; renew spacers only	05.10.20	0.2	C2D38514	2
K196	C	Check for cracks; renew spacers only Drive in/drive out	05.10.20 10.10.10	0.2 0.1	C2D38514 -	2 -
K196	D	Fit spacers; renew tray latches - Bordeaux	76.14.16	0.2	C2D 38514 C2D16173CJB	2 2
K196	E	Fit spacers; renew tray latches - Bordeaux Drive in/drive out	76.14.16 10.10.10	0.2 0.1	C2D 38514 C2D16173CJB -	2 2 -
K196	F	Fit spacers; renew tray latches - Cashew	76.14.16	0.2	C2D 38514 C2D13489APH	2 2
K196	G	Fit spacers; renew tray latches - Cashew Drive in/drive out	76.14.16 10.10.10	0.2 0.1	C2D 38514 C2D13489APH -	2 2 -
K196	H	Fit spacers; renew tray latches - Dove	76.14.16	0.2	C2D 38514 C2C22254LHJ	2 2
K196	J	Fit spacers; renew tray latches - Dove Drive in/drive out	76.14.16 10.10.10	0.2 0.1	C2D 38514 C2C22254LHJ -	2 2 -
K196	K	Fit spacers; renew tray latches - Ebony	76.14.16	0.2	C2D 38514 C2D16173PVJ	2 2
K196	L	Fit spacers; renew tray latches - Ebony Drive in/drive out	76.14.16 10.10.10	0.2 0.1	C2D 38514 C2D16173PVJ -	2 2 -
K196	M	Fit spacers; renew tray latches - London Tan	76.14.16	0.2	C2D 38514 C2D13489APJ	2 2
K196	N	Fit spacers; renew tray latches - London Tan Drive in/drive out	76.14.16 10.10.10	0.2 0.1	C2D 38514 C2D13489APJ -	2 2 -

K196	P	Fit spacers; renew tray latches - Navy	76.14.16	0.2	C2D 38514 C2D13489JMN	2 2
K196	R	Fit spacers; renew tray latches - Navy Drive in/drive out	76.14.16 10.10.10	0.2 0.1	C2D 38514 C2D13489JMN -	2 2 -
K196	S	Fit spacers; renew tray latches - Ivory	76.14.16	0.2	C2D 38514 C2D13489NUG	2 2
K196	T	Fit spacers; renew tray latches - Ivory Drive in/drive out	76.14.16 10.10.10	0.2 0.1	C2D 38514 C2D13489NUG -	2 2 -
K196	V	Fit spacers; renew tray latches - Parchment	76.14.16	0.2	C2D 38514 C2D16173VAE	2 2
K196	W	Fit spacers; renew tray latches - Parchment Drive in/drive out	76.14.16 10.10.10	0.2 0.1	C2D 38514 C2D16173VAE -	2 2 -

Normal Warranty policies and procedures apply

SERVICE INSTRUCTION:

1. Open the left-hand seatback business tray.



E127925

2.  **NOTE: On removal of the business tray latch remove and discard any washers behind the fixing.**

Remove the seatback business tray latch.

1. Remove the fixing.

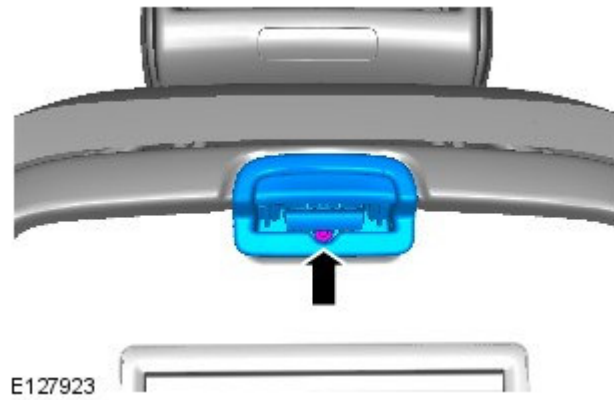

3. Install the new spacer.



4. To install, reverse steps 1-2.

5. Carry out steps 1-4 to the right-hand seatback business tray latch.