

Technical product information

Topic	W12 - Oil leak from engine
Market area	Bentley; worldwide (2WBE)
Brand	Bentley
Transaction No.	2053350/4
Level	EH
Status	Released for publishing
Release date	09-Nov-2022

New customer code

Object of complaint	Complaint type	Position
whole vehicle -> vehicle areas -> engine compartment	leaks -> oil leak	

Vehicle data

New Continental GT/C and New Flying Spur

Sales types

Type	MY	Brand	Designation	Engine code	Gearbox code	Final drive code
3S31BB	2018	E		*	*	*
3S31BB	2019	E		*	*	*
3S31BB	2020	E		*	*	*
3S31BB	2021	E		*	*	*
3S31BB	2022	E		*	*	*
3S31BB	2023	E		*	*	*
3S31EB	2021	E		*	*	*
3S31EB	2022	E		*	*	*
3S31EB	2023	E		*	*	*
3S41BB	2019	E		*	*	*
3S41BB	2020	E		*	*	*
3S41BB	2021	E		*	*	*
3S41BB	2022	E		*	*	*
3S41BB	2023	E		*	*	*
3S41EB	2021	E		*	*	*
3S41EB	2022	E		*	*	*
3S41EB	2023	E		*	*	*
ZG21BB	2020	E		*	*	*
ZG21BB	2021	E		*	*	*
ZG21BB	2022	E		*	*	*
ZG21BB	2023	E		*	*	*
ZG26BB	2023	E		*	*	*

Bentayga

Sales types

Type	MY	Brand	Designation	Engine code	Gearbox code	Final drive code
4V14A9	2017	E		*	*	*
4V14A9	2018	E		*	*	*
4V14A9	2019	E		*	*	*
4V14A9	2020	E		*	*	*
4V14A9	2021	E		*	*	*
4V14A9	2022	E		*	*	*
4V14A9	2023	E		*	*	*
4V14G9	2020	E		*	*	*
4V14G9	2021	E		*	*	*

4V14G9	2022	E		*	*	*
4V14G9	2023	E		*	*	*

Documents

Document name
master.xml

Customer statement / workshop findings

Oil leak from engine area.

Technical background

The breather return line and the oil dipstick tube O-rings can split causing an external oil leak.

This can be misdiagnosed as the engine sump leaking.



Production change

*

Measure

If an engine oil leak is found from the area shown in Figure 1, check the O-rings of both the breather return line and the dipstick tube for leakage. The oil can run down the engine and settle on the sump leading to misdiagnosis, Figure 1.



Figure 1

1. Firstly check the breather return line for signs an oil leak in area highlighted in Figure 2. Should a leak be evident, remove the tube and check the O-ring for damage.

Power unit → Engine lubrication → 6.0 L W12 TSI → Oil breather system return line – To remove and fit

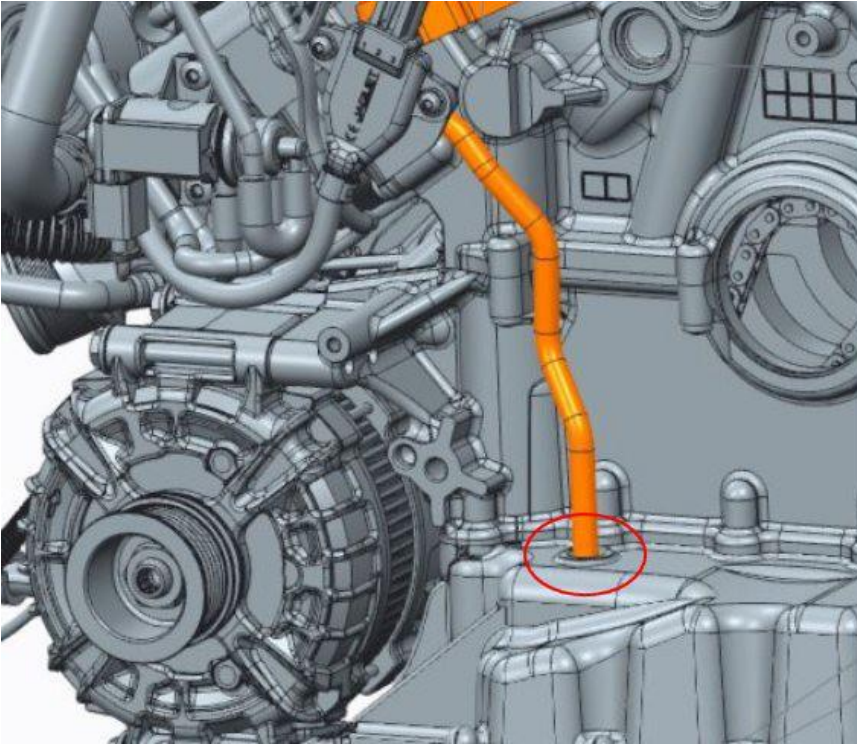

Figure 2

2. Check the dipstick tube for signs of an oil leak in area highlighted in Figure 3. Should a leak be evident, remove the dipstick tube and check the O-ring for damage.

Power unit → Engine lubrication → 6.0 L W12 TSI → Assembly dipstick and tube – To remove and fit

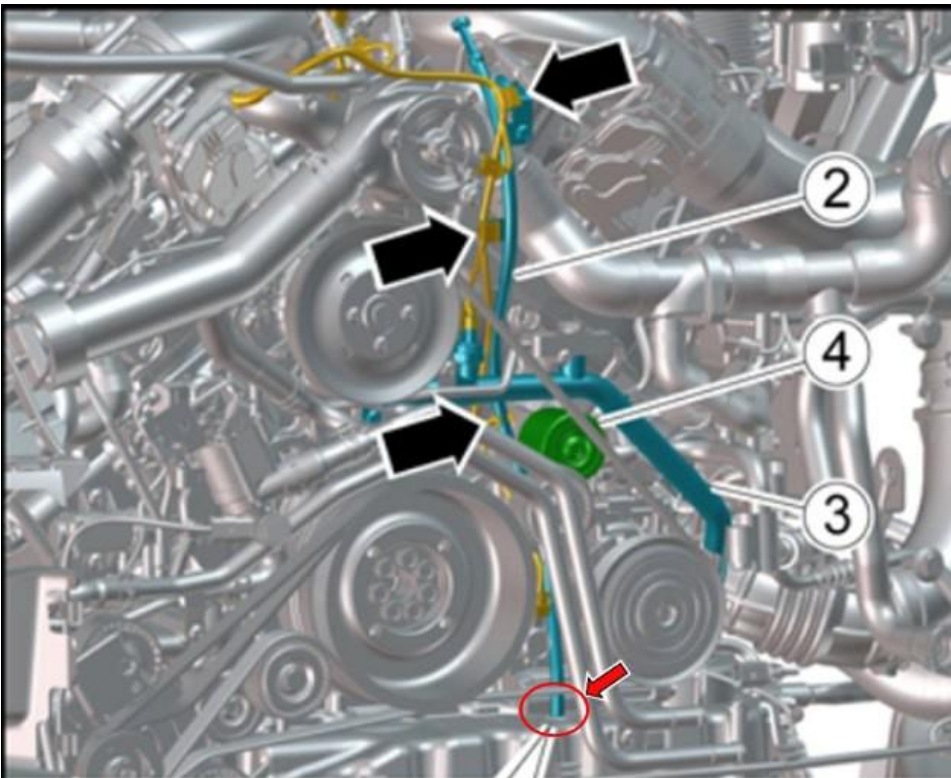

Figure 3

Should either of the O-rings be damaged or leaking replace according to ETKA.