

Technical product information

Topic	Secondary air injection - Missing ODIS data
Market area	Russische Föderation (5RU),Australia E04 Bentley rest Asia and Australia (6E04),China 796 VW Import Comp. Ltd (Vico), Beijing (6796),Germany E02 Bentley rest Europe (6E02),Japan E03 Bentley Japan (6E03),Korea, (South) E08 Bentley South Korea (6E08),United Arab Emirates E06 Bentley Middle East and Africa (6E06),United Kingdom E01 Bentley UK (6E01),United States E05 Bentley USA and rest America (6E05)
Brand	Bentley
Transaction No.	2061064/2
Level	EH
Status	Released for publishing
Release date	04-Nov-2022

New customer code

Object of complaint	Complaint type	Position
engine -> engine operation -> engine refinement	functionality -> misfire	
information, navigation, communication, entertainment -> symbolic fault indicators -> emission control system fault indicator	functionality -> activates	
vehicle service -> vehicle diagnosis -> guided fault finding	control units, services -> with event log entry	
vehicle service -> service, maintenance	control units, services	

Vehicle data

New Continental GT - GTC and New Flying Spur

Sales types

Type	MY	Brand	Designation	Engine code	Gearbox code	Final drive code
3S3*	2020	E		*	*	*
3S3*	2021	E		*	*	*
3S3*	2022	E		*	*	*
3S3*	2023	E		*	*	*
3S4*	2020	E		*	*	*
3S4*	2021	E		*	*	*
3S4*	2022	E		*	*	*
3S4*	2023	E		*	*	*
ZG2*	2020	E		*	*	*
ZG2*	2021	E		*	*	*
ZG2*	2022	E		*	*	*
ZG2*	2023	E		*	*	*

Documents

Document name
master.xml

Customer statement / workshop findings

Not all data for the secondary air injection operation is available when using ODIS

Technical background

Data is only available for four of the eight secondary air monitors on each cylinder bank therefore some test plans and related tasks are not currently available

- Figure 1 shows the expected Secondary air injection data

Operation	Diagnostic	DTC
Secondary Air Monitor Bank1	Flow check/functional check	P0491/P0492
Bank 1	Blockage check/leakage check	P0491/P0492
Bank 1	Pressure check	P0410
Bank 1	Tightness check	P2440
Bank 1	Tightness check	P2440
Bank 1	Tightness check	P2440
Secondary Air Monitor Bank3	Blockage or leakage check	P1497
Bank 3	Tightness check	P2442

Figure 1

- Figure 2 shows the actual data which can currently be viewed

Operation	Diagnostic	DTC
Secondary Air Monitor Bank1	Flow check	P0491
Bank 1	Pressure check	P0410
Bank 1	Tightness check	P2440
Secondary Air Monitor Bank3	Tightness check (Bank3)	P2442

Figure 2

- Figure 3 shows the layout of the secondary air injection system

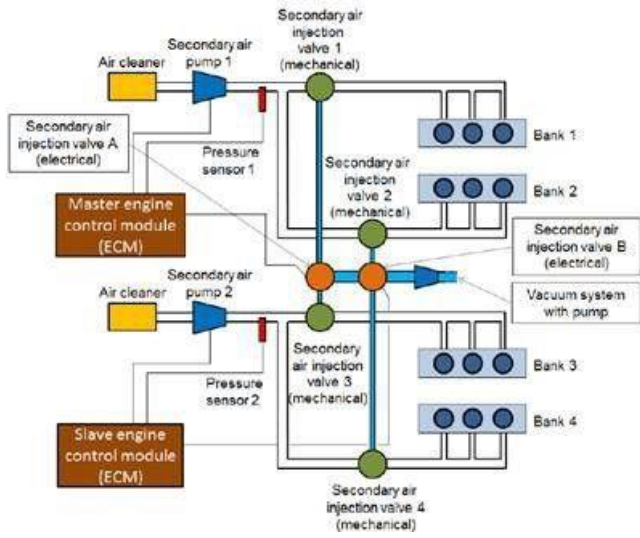

Figure 3

Production change

The issue will be addressed with a calibration change at the next opportunity

Measure

Not applicable