

JLRTB02109NAS1  
**TECHNICAL BULLETIN**  
01 SEP 2022



© Jaguar Land Rover North America, LLC

NOTE: The information in Technical Bulletins is intended for use by trained, professional Technicians with the knowledge, tools, and equipment required to do the job properly and safely. It informs these Technicians of conditions that may occur on some vehicles, or provides information that could assist in proper vehicle service. The procedures should not be performed by 'do-it-yourselfers'. If you are not a Retailer, do not assume that a condition described affects your vehicle. Contact an authorized Land Rover service facility to determine whether this bulletin applies to a specific vehicle.

INFORMATION

---

SECTION:

412-01

---

SUBJECT/CONCERN:

Air Conditioning (A/C) Inoperative

---

AFFECTED VEHICLE RANGE:

MODEL:	MODEL YEAR:	VIN:	ASSEMBLY PLANT:
I-PACE (X590)	2019-2020	F60001-F90422	Graz (Austria)
I-PACE (X590)	2020-2023	600001-626745	Graz (Austria)

---

MARKETS:

NORTH AMERICA

---

**CONDITION SUMMARY:****SITUATION:**

The Air Conditioning (A/C) does not blow cold and is found to be inoperative. Further investigation has found a leak on the A/C compressor inlet and/or outlet pipes. **New level service parts are available and even if only 1 pipe is found to be leaking, both pipes must be renewed.**

**CAUSE:**

Low weld quality.

**ACTION:**

Follow the instruction(s) below.

**PARTS:**

PART NUMBER	DESCRIPTION	QUANTITY
T4K19677	High Pressure (HP) pipe	1
T4K19719	Low Pressure (LP) pipe	1
T2H3162	Subframe to body bolts	2
J9C2719	Subframe to body bolts	4
XR857426	Steering column bolt	1
T2H5007	Front lower arm nut	4
T4K5106	Front lower arm bolt	2
T2H3774	Front lower arm bolt	2
T2H5057	Steering gear boot clips	2
T2H17786	Yolk to lower arm bolt	2
T4N8037	Tie-rod end nut	2
C2P7444	Stabilizer bar link nut	2
T4A12521	Halfshaft circlip	2
T4K2896	Front Electric Drive Unit (EDU) vibration damper	1

PART NUMBER	DESCRIPTION	QUANTITY
C2Z2224	Front EDU mounting nut	1
J9D1169	Seal	1

**WARRANTY:**

**NOTE:**

\* When submitting your Warranty claim within the Warranty portal, use the Condition Code list shown to select the Condition Code which best describes the vehicle defect.

**NOTES:**

- Repair procedures are under constant review, and therefore times are subject to change; those quoted here must be taken as guidance only. Use TOPIx to obtain the latest repair time.
- The JLR claims submission system requires the use of causal part numbers. Labor only claims must show the causal part number with a quantity of zero.

DESCRIPTION	SRO	TIME (HOURS)	CONDITION CODE	CAUSAL PART
JLRTB - A/C compressor pipe - Pair - Renew	99.01.82	8.7	*	J9D1139/T4K1278
Wheel alignment	57.64.99	0.6	*	J9D1139/T4K1278

**NOTE:**

Normal Warranty procedures apply.

## SERVICE INSTRUCTION:

**NOTES:**

- Some components shown removed for clarity.
- Some variation in the illustrations may occur, but the essential information is always correct.

1. Recover the A/C refrigerant (see TOPlx Workshop Manual section 412-00: Climate Control System - General Information - General Procedures - Air Conditioning System Recovery, Evacuation and Charging).
2. Remove the front EDU for access only (see TOPlx Workshop Manual section 601-01: Electric Drive Unit - Removal and Installation - Front Electric Drive Unit).

3.

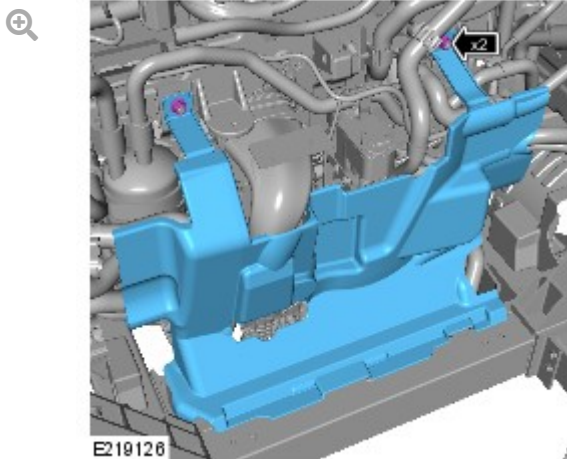

Remove the cover.

- Remove the 2 nuts.
  - Torque: **10 Nm**

4.

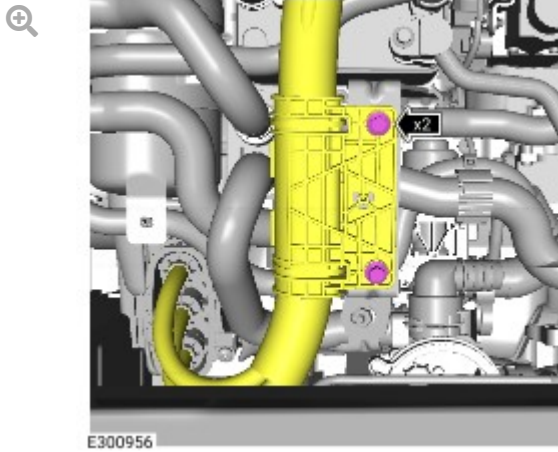

Reposition the High Voltage (HV) harness away from the bracket.

- Remove the 2 bolts.
  - Torque: **10 Nm**

5.

**NOTE:**

A new O-ring must be installed during installation.

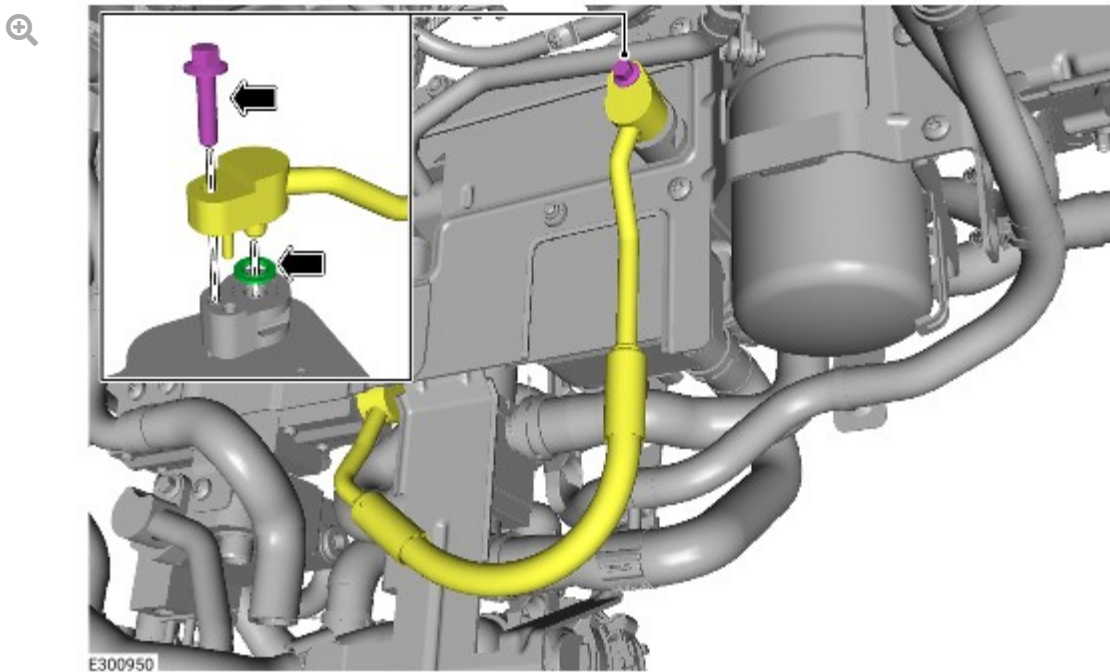

Disconnect the A/C pipe.

- Remove the bolt.
  - Torque: **12 Nm**

6.

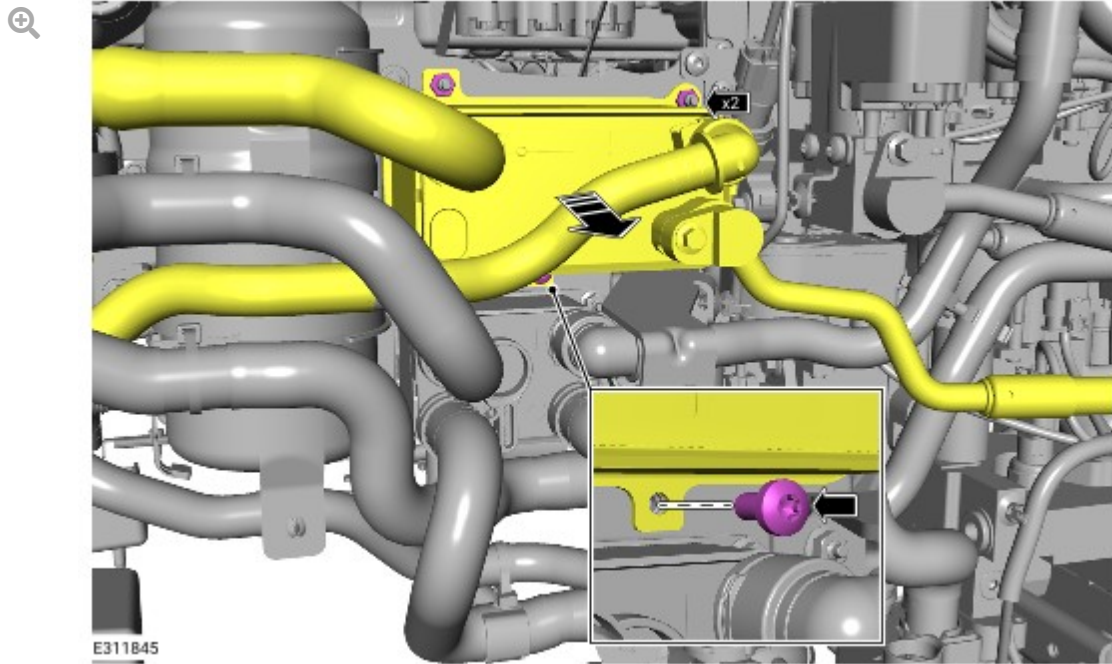

Reposition the indirect condenser away from the bracket.

- Remove the 2 nuts.
  - Torque: **10 Nm**
- Remove the bolt.
  - Torque: **12 Nm**

7.

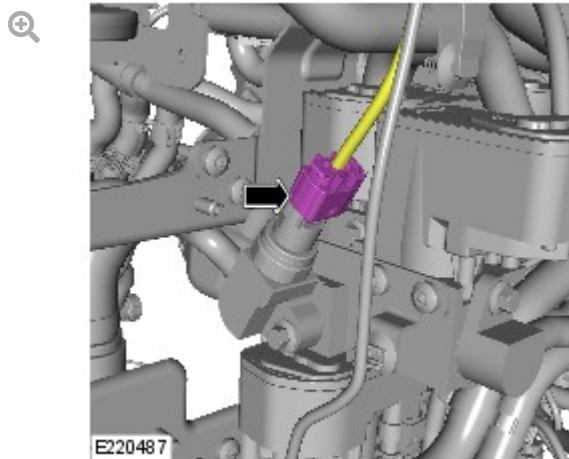

Disconnect the electrical connector from the A/C HP temperature sensor.

8.

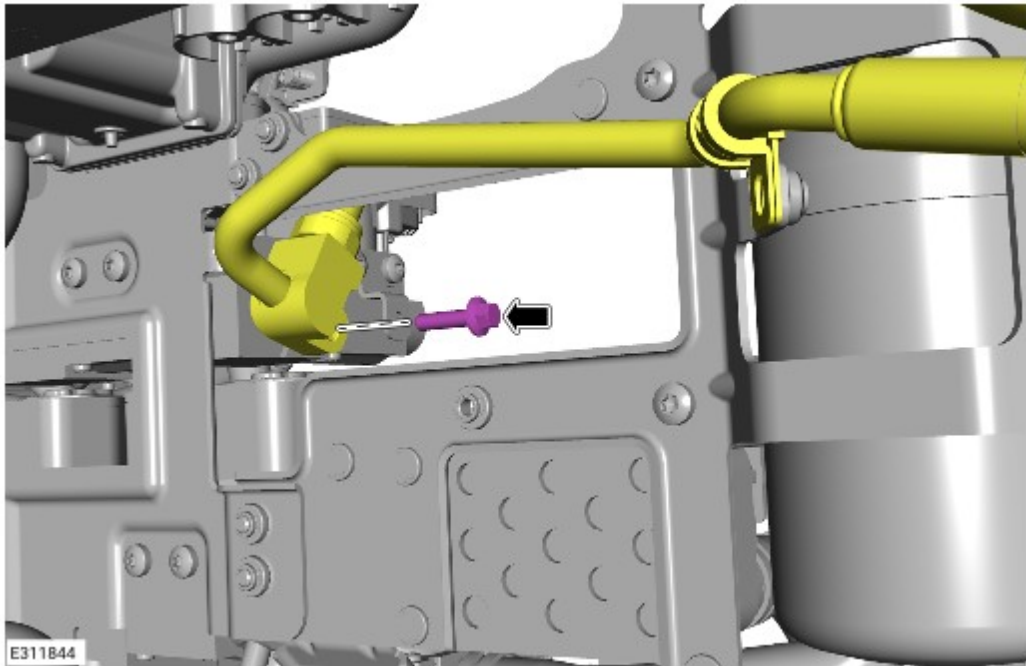

Disconnect the A/C pipe.

- Remove the bolt.
- Torque: **12 Nm**

9.

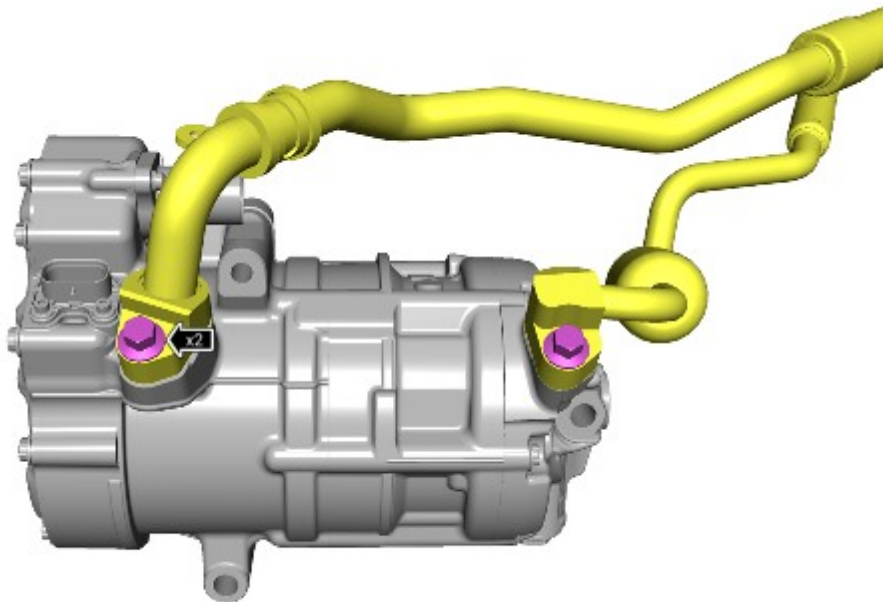

E311843

Disconnect both A/C pipes from the A/C compressor.

- Remove the 2 bolts.
- Torque: **24 Nm**



10.

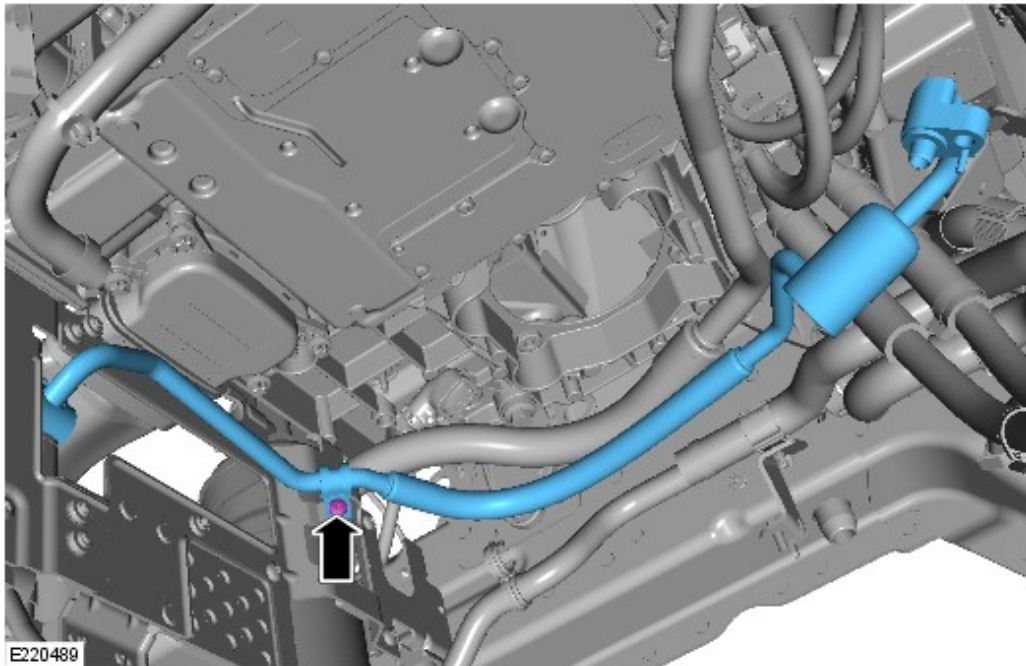

Remove the A/C compressor HP pipe.

- Remove the bolt.
- Torque: **8 Nm**

11.

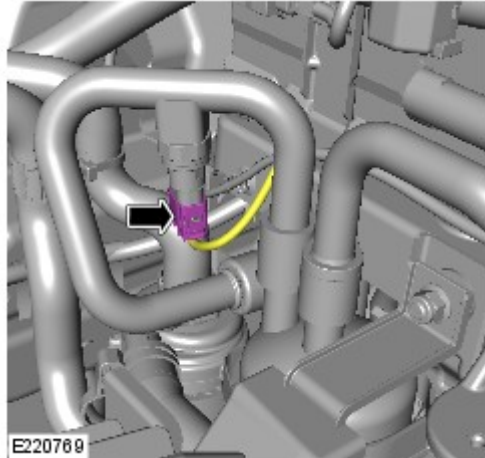

Disconnect the electrical connector from the A/C temperature and pressure sensor.



12.

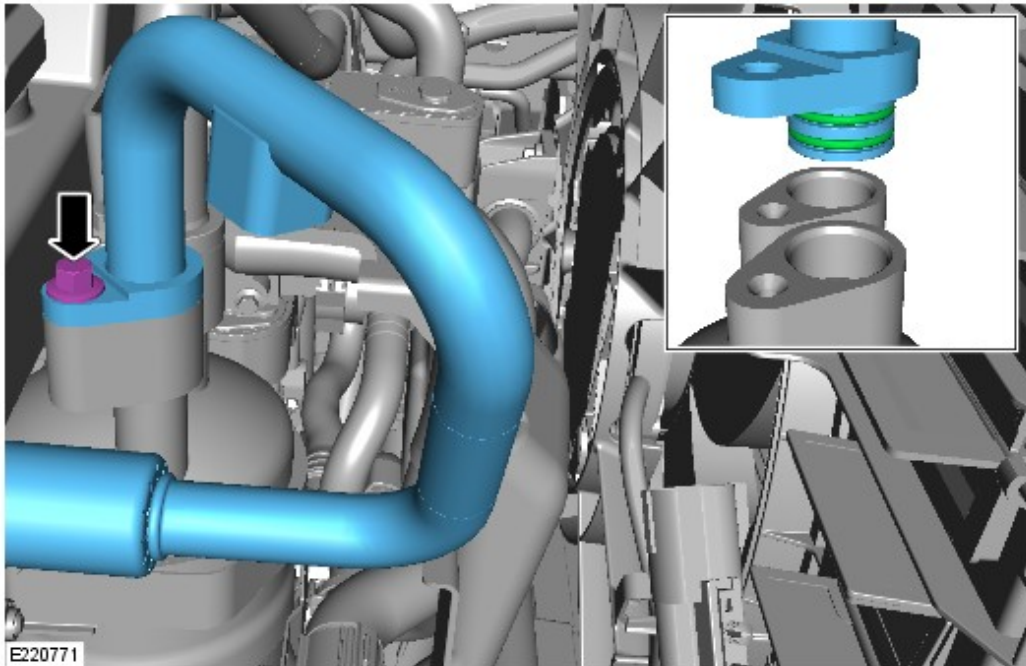

Disconnect the A/C compressor LP inlet pipe from the accumulator and remove the pipe.

- Remove the bolt.
  - Torque: **10 Nm**

13.

**CAUTION:**

Only the front wheel alignment may be affected by the repair procedure outlined in this technical bulletin. If the rear wheel alignment is found to be out of specification, this must be investigated and rectified separately, not as part of this technical bulletin. If the rear wheel alignment is found to be out of specification, the rear toe link locking nuts must be renewed separately, not as part of this technical bulletin.

To install the new A/C pipes, reverse steps 1 to 12.