



Revised July 2020

Dealer Service Instructions for:

Emissions Recall V86

Catalytic Converter Efficiency

NOTE: The Subject has been revised.

Remedy Available

2015-2017 (LA) Dodge Challenger Hellcat

2015-2017 (LD) Dodge Charger Hellcat

NOTE: This recall applies only to the above vehicles equipped with a 6.2L supercharged engine (sales code ESD).

NOTE: Some vehicles within the above build period may have been identified as not involved in this recall and therefore have been excluded from this recall.

IMPORTANT: Some of the involved vehicles may be in Dealer vehicle inventory. Dealers should complete this recall service on these vehicles before retail delivery. Involved vehicles can be determined by using the VIP inquiry process.

Subject

Degradation of the catalytic converter on about 25,180 of the above vehicles may result in those vehicles exceeding the emissions standards for Non-Methane Organic Gas (NMOG) and Nitrogen Oxide (NOx).

Repair

Update the Powertrain Control Module (PCM) with the latest available software.
Replace the catalytic converters and the oxygen sensors.

Parts Information

<u>Part Number</u>	<u>Description</u>
CEAHV861AA	Catalyst - Right Side

Each package contains the following components:

<u>Quantity</u>	<u>Description</u>
1	Catalyst - Right Side

<u>Part Number</u>	<u>Description</u>
CEAHV862AA	Catalyst - Left Side

Each package contains the following components:

<u>Quantity</u>	<u>Description</u>
1	Catalyst - Left Side

<u>Part Number</u>	<u>Description</u>
CEAHV863AA	Campaign Kit - Parts Package

Each package contains the following components:

<u>Quantity</u>	<u>Description</u>
4	Catalyst Nut - 2 per catalyst
4	Double Ended Stud - 2 per catalyst
1	O2 sensor – Left Side Upstream
1	O2 sensor – Right Side Upstream
2	O2 sensor – Left Side/Right Side Downstream

Parts Information [Continued]

Part Number

04275086AE – Authorized Modification Label

Ordering Additional Authorized Modification labels:

The labels may be ordered using the Marketing Materials link within DealerCONNECT.

Process Steps to Order Additional labels and extended warranty information kits:

1. Access the “**DealerCONNECT**” website.
2. Select the “**Marketing**” link in the header of DealerCONNECT.
3. Locate the “**Product Information**” section heading on the Marketing page.
4. Select the “**Literature and Merchandising Materials**” link in the product information section.
5. Locate the “**MOPAR**” section heading on the Literature and Merchandising Materials page.
6. Select the “**Recall Labels / Cards**” link listed in the MOPAR section.
7. **Select Item > Update Cart > Submit Order.**

Parts Return

Return the Catalyst to the Mopar Core Return Center for core credit.

Refer to Section E under Service Procedure for proper Core Return preparation.

Service Procedure

A. Reprogram the ECM with the Latest Available Software

NOTE: The wiTECH scan tool must be used to perform this recall. If the reprogramming flash for the PCM is aborted or interrupted, repeat the procedure.

CAUTION: the PCM software must be at the latest software calibration level after completing this recall.

1. Open the hood and install a battery charger. Verify that the charging rate provides 13.0 to 13.5 volts. Do not allow the charger to time out during the flash process. Set the battery charger timer (if so equipped) to continuous charge.

NOTE: Use an accurate stand-alone voltmeter. The battery charger volt meter may not be sufficiently accurate. Voltages outside of the specified range will cause an unsuccessful flash. If voltage reading is too high, apply an electrical load by activating the park or headlamps and/or HVAC blower motor to lower the voltage.

2. Connect the wiTECH micro pod II to the vehicle data link connector.
3. Place the ignition in the “**RUN**” position.
4. Open the wiTECH 2.0 website.
5. Enter your “**User id**” and “**Password**” and your “**Dealer Code**”, then select “**Sign In**” at the bottom of the screen. Click “**Accept**”.
6. From the “**Vehicle Selection**” screen, select the vehicle to be updated.
7. From the “**Action Items**” screen, select the “**Topology**” tab.

Service Procedure [Continued]

8. From the “**Topology**” tab, select the “**PCM**” module icon.
9. From the “**Flash**” tab, compare the “**Current Electronic Control Unit (ECU) Part Number**” with the “**New ECU Part Number**” listed.
 - If the “**Current ECU part Number**” is the same as the “**New Part Number**”, proceed to **Step 15**.
 - If the “**Current ECU part Number**” is NOT the same as the “**New Part Number**”, continue with **Step 10**.
10. From the PCM tab, select the PCM flash part number. Read the flash special instructions page. Select “**OK**” to continue.

NOTE: 2015 model year vehicles only will receive updated software for the TCM while flashing the TCM as a combined flash. It will not be necessary to flash the TCM separately, follow the screen instructions to complete the flash.
11. From the flash ECU agreement page, agree to terms by checking the box.
12. Select “**Flash ECU**” and then follow the wiTECH screen instructions to complete the flash.
13. Confirm the software is at the latest available calibration level.
14. Click “**View DTCs**”, select “**Clear All DTCs**”, click “**Continue**” and then click “**Close**”.
15. Place the ignition in the “**OFF**” position and then remove the wiTECH micro pod II device from the vehicle.
16. Remove the battery charger from the vehicle.
17. Proceed to Section **B. Replace Catalytic Converters**.

Service Procedure [Continued]

B. Replace Catalytic Converters

1. Make sure ignition switch is in “OFF” position and all accessories are turned OFF.
2. Remove the rear compartment floor, trim panel to gain access to the battery.

3. Loosen the M6 captive nut (1) securing the battery negative cable clamp to the battery negative post (Figure 1).

NOTE: Do not remove the M6 captive nut, doing so will cause the M6 stud on IBS pole clamp to break.

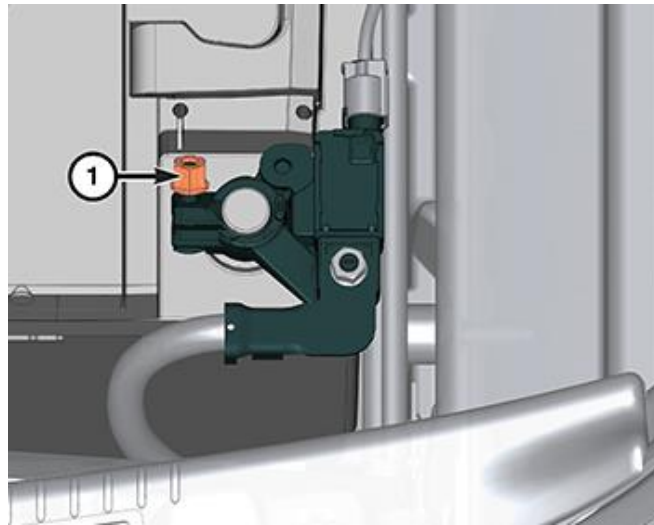

Figure 1 – Battery Negative Terminal Nut

4. Disconnect the Intelligent Battery Sensor (IBS) electrical connector (1) (Figure 2).

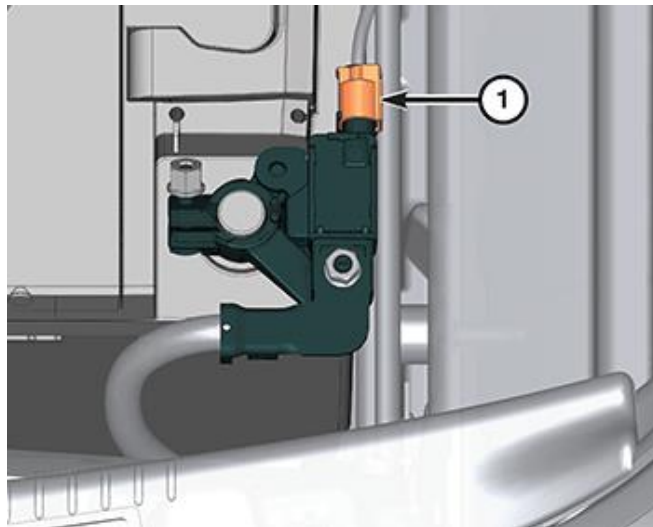

Figure 2 – IBS Electrical Connector

Service Procedure [Continued]

5. Remove the M8 hex nut (1) securing the battery negative cable eyelet to the IBS (Figure 3).

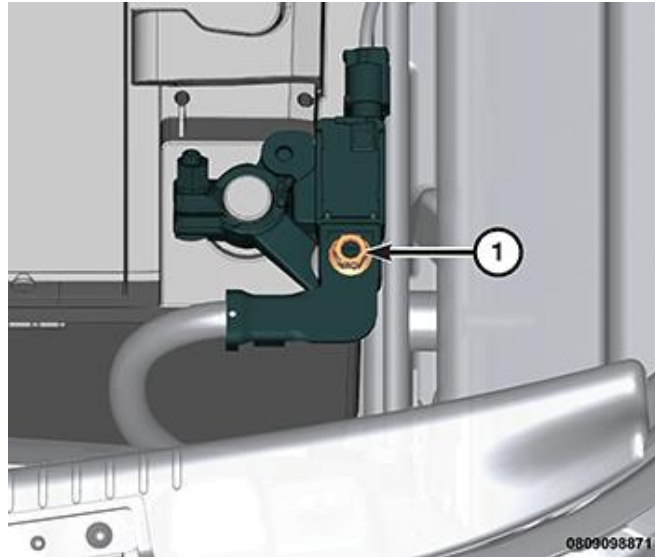

Figure 3 – Negative Cable Eyelet Nut

6. Remove the battery negative cable eyelet (2) from the IBS M8 stud (Figure 4).

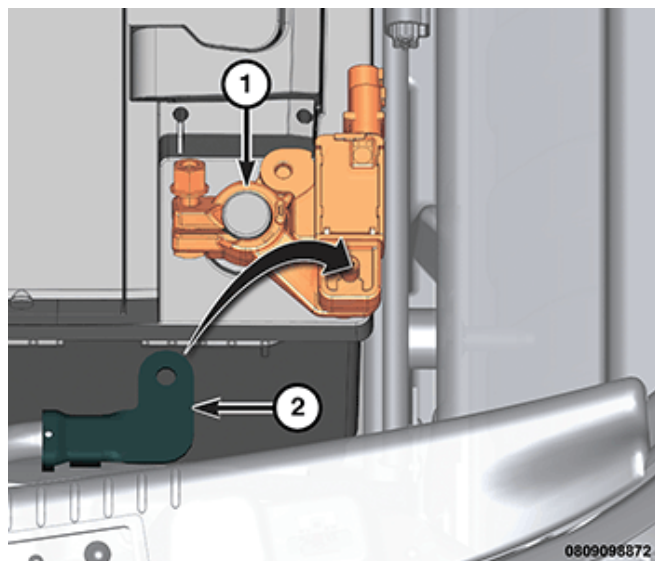

Figure 4 – Negative Cable Eyelet

7. Raise and support the vehicle.

Service Procedure [Continued]

8. Saturate all exhaust bolts and nuts with Mopar® Rust Penetrant. Allow five minutes for penetration.

WARNING: The normal operating temperature of the exhaust system is very high. Therefore, never attempt to service any part of the exhaust system until it is cooled. Special care should be taken when working near the catalytic converter. The temperature of the converter rises to a high level after a short period of engine operation time.

CAUTION: When disconnecting the oxygen sensor electrical connector, do not pull directly on the wire going into the sensor. The sensor wiring can be damaged resulting in sensor failure.

9. Disconnect the oxygen sensor wire harness connector (1) and remove the harness from the retainer (2) (Figure 5).

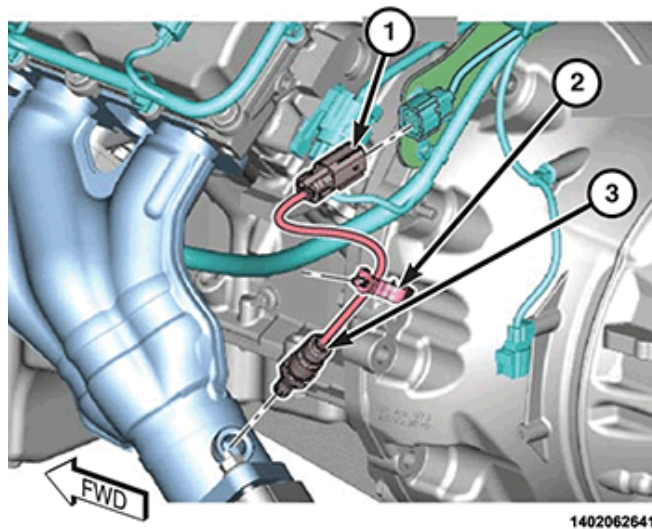

Figure 5 – Oxygen Sensors

10. Remove the oxygen sensor (3) from the exhaust manifold (Figure 5).
11. Disconnect the oxygen sensor wire harness connector (2) and remove the harness from the retainer (Figure 6).

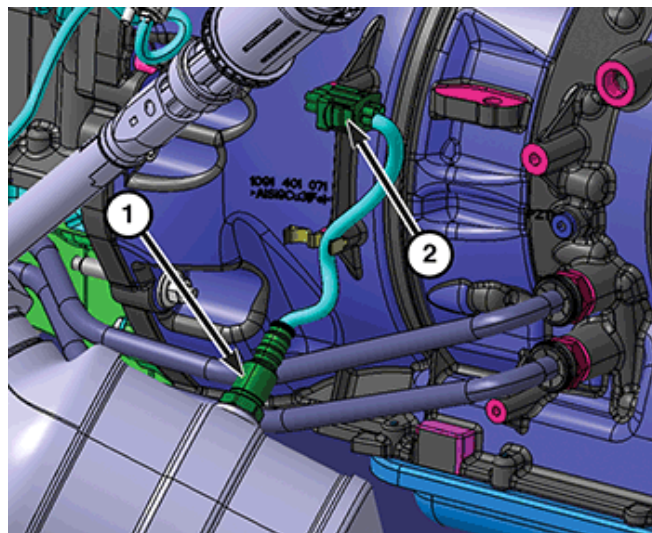
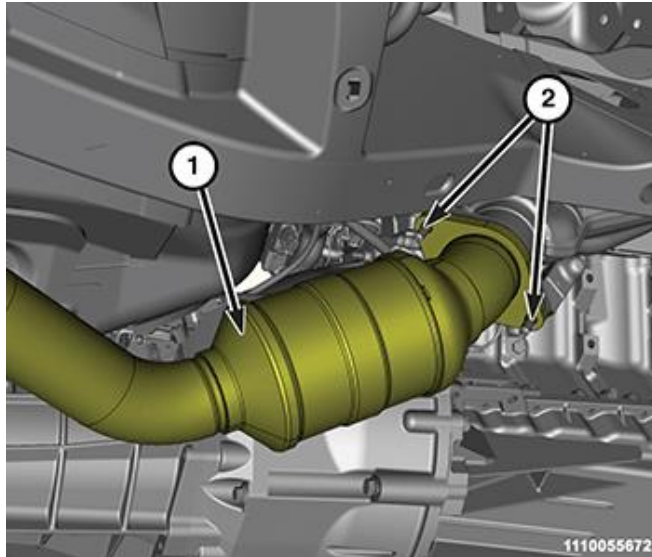

Figure 6 – Oxygen Sensors

Service Procedure [Continued]

12. Remove the catalytic converter to manifold flange nuts (2) and separate the catalytic converters (1) from the exhaust manifolds (Figure 7).

**Figure 7 – Flange Nuts**

13. Loosen the front exhaust pipe to muffler and resonator assembly band clamps (1) (Figure 8).

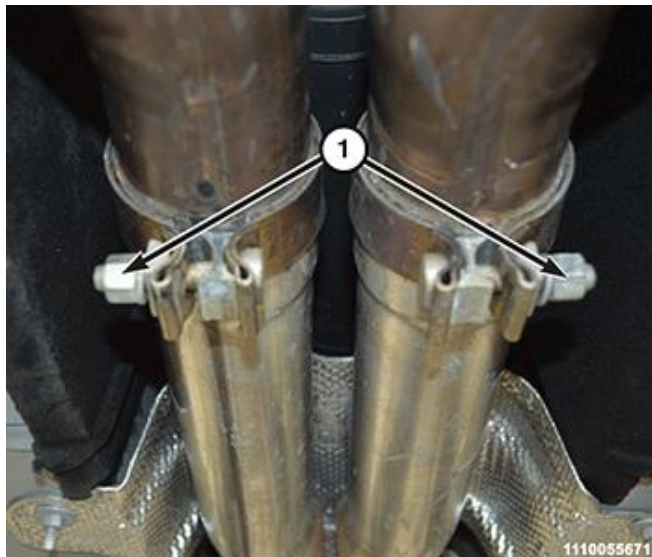
**Figure 8 – Band Clamps**

Service Procedure [Continued]

14. Separate the muffler and resonator assembly from the catalytic converters.
15. Remove the left (1) and/or right (2) catalytic converters (Figure 9).
16. Position the left (1) and/or right (2) catalytic converter onto the exhaust manifold flange, and install the flange nuts finger tight (Figure 9).

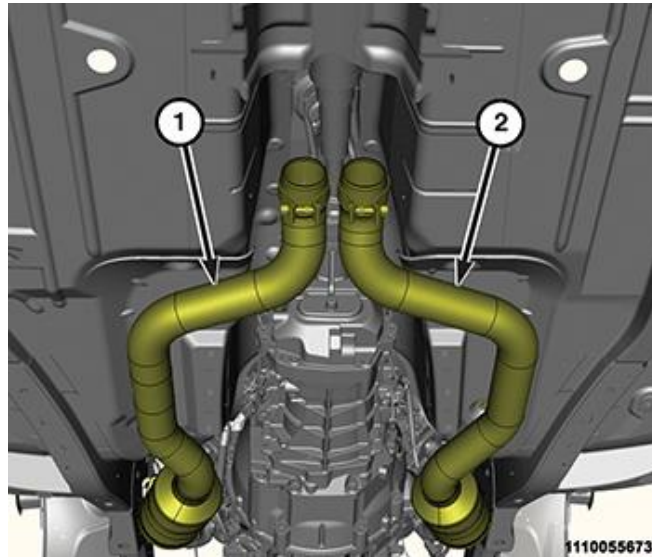
**Figure 9 – Catalytic Converters**

17. Insert the muffler and resonator assembly onto the front exhaust pipe, without tightening the band clamps (1) at this time (Figure 8).
18. Tighten the catalytic converter (1) to exhaust manifold flange nuts (2) to 30 N·m (22 ft. lbs.) (Figure 7).
19. Tighten the band clamps to 50 N·m (37 ft. lbs.) (Figure 8).

NOTE: The threads of the new oxygen sensors are factory coated with anti-seize compound to aid in removal. Do not add any additional anti-seize compound to threads of a new oxygen sensor.

20. Install the oxygen sensor (3) into the exhaust manifold and tighten to 52 N·m (38 ft. lbs.) (Figure 5).
21. Connect the oxygen sensor wire harness connector (1) and secure the wire harness in the retainer (2) (Figure 5).

Service Procedure [Continued]

22. Install the oxygen sensor (1) and tighten to 52 N·m (38 ft. lbs.) (Figure 6).
23. Connect the oxygen sensors wire harness connector (2) and secure the wire harness in the retainer (Figure 6).
24. Lower the vehicle.

NOTE: Connecting the negative battery cable to the Intelligent Battery Sensor (IBS) must be done before installing on the battery post.

NOTE: DO NOT use a hammer to tap down the sensor. Use a post spreader to open the post if reusing the existing sensor.

NOTE: Avoid IBS rotation during tightening of M8 nut as to avoid contact of 2-way connector breakage when rotating in to the battery.

25. Connect the battery negative cable eyelet (2) to the IBS M8 stud (Figure 4).
26. Install the M8 hex nut (1) to the IBS and tighten the nut to 15 N·m (11 ft. lbs.) (Figure 3).

NOTE: M8 has much higher torque than the M6 clamp and can break IBS free if the M6 is tightened prior.

27. Tighten the battery negative cable clamp M6 nut (1) to 7 N·m (62 in. lbs.) (Figure 1).
28. Install the electrical connector (1) to the IBS. Make sure there is no stress on the wires (Figure 2).
29. Install the rear compartment floor trim panel.
30. Proceed to: **Section C.** Install the Authorized Modifications Label.

Service Procedure [Continued]

C. Install the Authorized Modifications Label:

1. Type or print (with a ballpoint pen) the necessary information shown in (Figure 10) onto the authorized modifications Label.
2. Remove the paper backing from the clear film on the front of the authorized modifications label then carefully apply the clear film over the front of the authorized modifications label (Figure 11).

NOTE: The Authorized Modifications Label should be located near the Vehicle Emission Control Information (VECI) label (Figure 12).

3. Locate the VECI label on the underside of the engine compartment hood (Figure 12).

NOTE: For vehicles missing a VECI label, locate a flat protected area on the underside of the hood to apply the authorized modifications label.

4. Clean the surface near the VECI label with isopropyl alcohol or equivalent and a soft cloth.

Chrysler Group LLC	AUTHORIZED MODIFICATIONS	THESE MODIFICATIONS HAVE BEEN APPROVED AS APPROPRIATE BY EPA AND CARB.
THE FOLLOWING MODIFICATIONS HAVE BEEN MADE:		
REPLACE CATALYTIC CONVERTER		
REPROGRAM POWERTRAIN CONTROL MODULE		
CHANGE AUTHORITY	DEALER CODE	DATE
RECALL V86	XXXXX	XX / XX / XXXX
04275086AD		

Figure 10 – Authorized Modifications Label

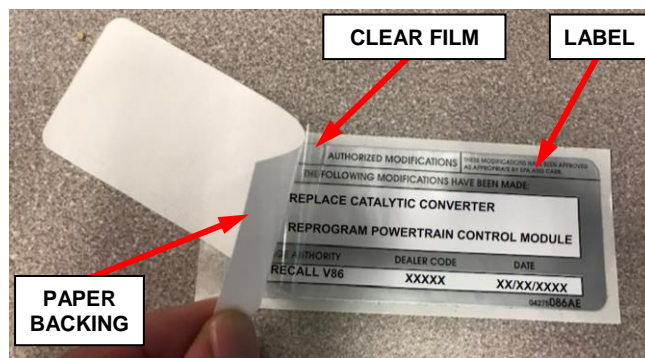

Figure 11 – Apply Clear Film

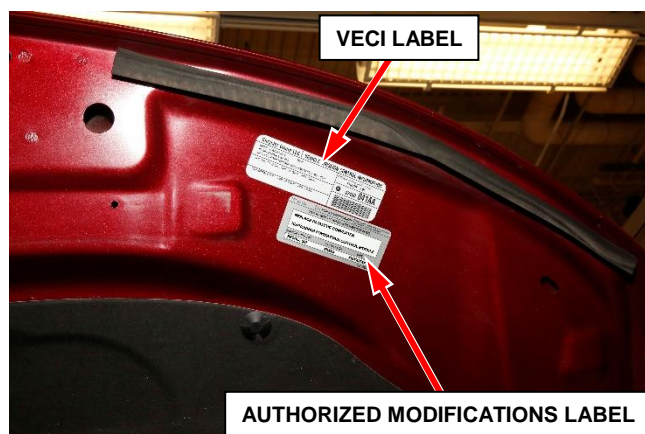

Figure 12 – Apply Authorized Modifications Label Near VECI Label (Specific Vehicle May Look Different)

Service Procedure [Continued]

5. Remove the authorized modifications label from its paper backing.
6. Apply the authorized modifications label next to the VECI label (Figure 12).
7. Firmly press and smooth the authorized modifications label to ensure good adhesion.
8. Close the engine compartment hood.
9. Complete the Proof of Correction Form for California Residents, **Section D**.
10. Prepare removed catalyst for core return, **Section E**.

Service Procedure [Continued]

D. Complete Proof of Correction Form for California Residents:

This recall is subject to the **State of California Registration Renewal/Emissions Recall Enforcement Program**. Complete a Vehicle Emission Recall Proof of Correction Form (**Form No. 81-016-1053**) and **supply it to vehicle owners residing in the state of California** for proof that this recall has been performed when they renew the vehicle registration.

Process Steps to obtain the California Proof of Correction form:

- a. Access the “**DealerCONNECT**” website.
- b. Select the “**Service**” tab.
- c. Under the “**Publications**” heading, select the “**ePublishing**” link.
- d. Sign in using your **Dealer Code** and **Password**.
- e. Select the “**Proof of Correction form**”.

Service Procedure [Continued]**E. Prepare Catalyst for Core Return:**

NOTE: Catalytic converter catalyst must be intact and all pipes must be completely removed prior to core return. It is not necessary to remove Oxygen (O₂) sensors for catalyst core return.

NOTE: Mopar® will reimburse only 50% of the core deposit on returns that do not comply with the above requirement.

1. Cut the outlet pipe off of the catalyst as close to the pipe weld as possible (Figure 11).
2. Return only the catalyst section for core deposit credit. Discard / recycle the pipes cut off of the catalyst section (Figure 11).

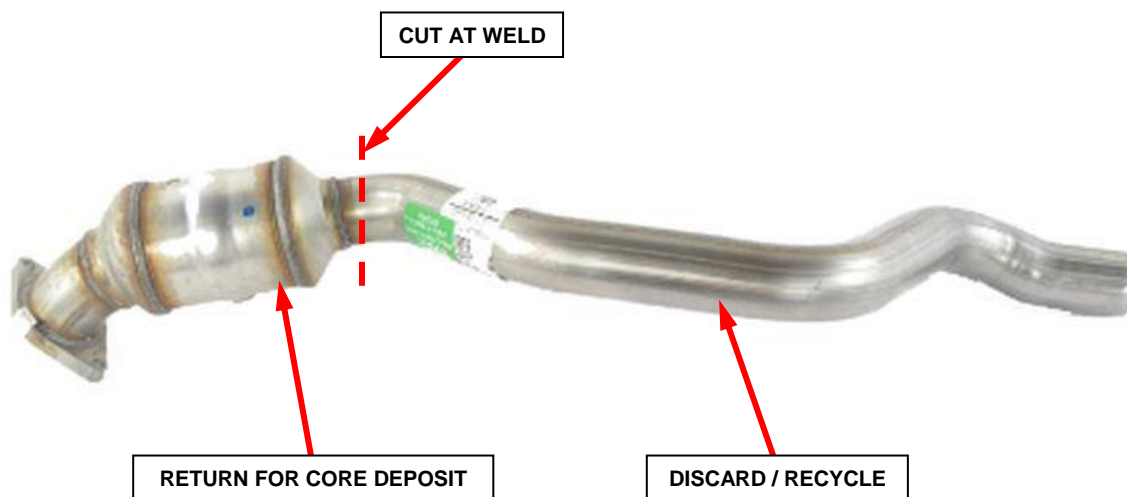

Figure 11 – Remove Pipes from Catalyst for Core Return

For any questions relating to Core Returns

Please call GCRS Customer Service Toll-Free at 866-254-2940

or

Submit your inquiry on Dealer Connect under Parts>Contact Global Core Returns

Completion Reporting and Reimbursement

Claims for vehicles that have been serviced must be submitted on the DealerCONNECT Claim Entry Screen located on the Service tab. Claims paid will be used by FCA to record recall service completions and provide dealer payments.

Use the following labor operation numbers and time allowances:

	Labor Operation Number	Time Allowance
Replace Catalysts, PCM Software Up to Date	11-V8-61-82	1.4 hours
Replace Catalysts and Update PCM Software	11-V8-61-83	1.5 hours
<u>Related:</u>		
Remove pipe from catalyst for core return up to \$3 reimbursement per vehicle for cutting supplies, bill as NPN	11-V8-61-50	0.2 hours

Add the cost of the recall parts package plus applicable dealer allowance to your claim.

NOTE: See the Warranty Administration Manual, Recall Claim Processing Section, for complete recall claim processing instructions.

Dealer Notification

To view this notification on DealerCONNECT, select “Global Recall System” on the Service tab, then click on the description of this notification.

Owner Notification and Service Scheduling

All involved vehicle owners known to FCA are being notified of the service requirement by first class mail. They are requested to schedule appointments for this service with their dealers. A generic copy of the owner letter is attached.

Vehicle Lists, Global Recall System, VIP and Dealer Follow Up

All involved vehicles have been entered into the DealerCONNECT Global Recall System (GRS) and Vehicle Information Plus (VIP) for dealer inquiry as needed.

GRS provides involved dealers with an updated VIN list of their incomplete vehicles. The owner's name, address and phone number are listed if known. Completed vehicles are removed from GRS within several days of repair claim submission.

To use this system, click on the “**Service**” tab and then click on “**Global Recall System.**” Your dealer's VIN list for each recall displayed can be sorted by: those vehicles that were unsold at recall launch, those with a phone number, city, zip code, or VIN sequence.

Dealers must perform this repair on all unsold vehicles before retail delivery. Dealers should also use the VIN list to follow up with all owners to schedule appointments for this repair.

Recall VIN lists may contain confidential, restricted owner name and address information that was obtained from the Department of Motor Vehicles of various states. Use of this information is permitted for this recall only and is strictly prohibited from all other use.

Additional Information

If you have any questions or need assistance in completing this action, please contact your Service and Parts District Manager.

Customer Services / Field Operations
FCA US LLC

This notice applies to your vehicle,

[Model Year and Model]

VIN XXXXXXXXXXXXXXXXXXXX

V86

LOGO

VEHICLE PICTURE

YOUR SCHEDULING OPTIONS

- 1. RECOMMENDED OPTION**
Call your authorized Chrysler / Dodge / Jeep® / RAM / Dealership
2. Call the FCA Recall Assistance Center at **1-800-853-1403**. An agent can confirm part availability and help schedule an appointment
3. Visit recalls.mopar.com, scan the QR code below, or download the Mopar Owner's Companion App.

QR Code

Get access to recall notifications, locate your nearest dealer, and more through this website or Mopar Owner's Companion App. You will be asked to provide your Vehicle Identification Number (VIN) to protect and verify your identity. The last eight characters of your VIN are provided above.

DEALERSHIP INSTRUCTIONS

Please reference Emissions Recall

V86

IMPORTANT EMISSIONS RECALL

Catalyst Efficiency

Dear [Name],

FCA US LLC, has determined that certain [2015-2017 Model Year (LA) Dodge Challenger Hellcat and 2015-2017 Model Year (LD) Dodge Charger Hellcat] vehicles equipped with a 6.2L supercharged engine may release air pollutants which exceed Federal and California standards.

WHY DOES MY VEHICLE NEED REPAIRS?

Degradation of the catalytic converter may result in your vehicle^[1] exceeding the emissions standards for Non-Methane Organic Gas (NMOG) and Nitrogen Oxide (NOx).

HOW DO I RESOLVE THIS IMPORTANT EMISSIONS ISSUE?

FCA will repair your vehicle free of charge (parts and labor). To do this, your dealer will update the Powertrain Control Module (PCM) software and replace both catalytic converters and the oxygen sensors. The estimated repair time is two hours. In addition, your dealer will require your vehicle for proper check-in, preparation, and check-out during your visit, which require more time. Your time is important to us, so we recommend that you schedule a service appointment to minimize your inconvenience. Please bring this letter with you to your dealership.

**TO SCHEDULE YOUR FREE REPAIR,
CALL YOUR CHRYSLER, DODGE, JEEP OR RAM DEALER TODAY
OUR DEALERSHIPS ARE OPEN AND TAKING THE NECESSARY STEPS TO
ENSURE A SAFE AND CONVENIENT EXPERIENCE.**

CALIFORNIA RESIDENTS

The State of California will require the completion of this emission recall repair prior to vehicle registration renewal after normal business conditions are reestablished. Owners can check the status of when this will occur by checking CARB's website <https://ww2.arb.ca.gov/emissions-recall-registration>. Your dealer will provide you with a Vehicle Emission Recall Proof of Correction Form after the Emission Recall service is performed. Be sure to save this form since the California Department of Motor Vehicles may require that you supply it as proof that the Emission Recall has been performed.

In order to ensure your full protection under the emissions warranty provisions, it is recommended that you have your vehicle serviced as soon as possible. Failure to do so could be determined as lack of proper maintenance of your vehicle.

WHAT IF I ALREADY PAID TO HAVE THIS REPAIR COMPLETED?

If you have already experienced this specific condition and have paid to have it repaired, you may visit www.fcarecallreimbursement.com to submit your reimbursement request online.^[2] Once we receive and verify the required documents, reimbursement will be sent to you within 60 days. If you have had previous repairs performed and/or already received reimbursement, you may still need to have the recall repair performed.

We apologize for any inconvenience, but are sincerely concerned about your satisfaction. Thank you for your attention to this important matter.

Customer Assistance/Field Operations
FCA US LLC



Mr. Mrs. Customer
1234 Main Street
Hometown, MI 48371



At Mopar®, the safety and well-being of everyone in our Dodge Brand family is always our top priority. In these unprecedented and quickly changing times, we know that vehicle service may not be top of mind.

Many states consider vehicle maintenance an essential service. Visit us online to see how we can help you care for your vehicle, including checking on any potential safety-related recalls. **Simply log in or register to see how to keep your vehicle ready for anything.** Should your vehicle need service, many of our Dodge Brand dealerships are open for business and taking the necessary steps to ensure a safe and convenient experience.

Added Protection:

- Seat, floor and steering wheel covers which will remain in your vehicle during the entire visit to the dealership
 - Disinfecting the areas of a vehicle touched by dealership personnel
- All employees instructed to follow CDC recommended hand washing procedures
 - Dealer technicians using gloves while servicing each vehicle

Care and Convenience:

- Drop off your vehicle using our night drop box any time of the day
 - Service progress updates provided via phone or text
 - Outside pick up of your vehicle when it is complete
- Vehicle pick up/drop off or mobile service available at select dealers

[1] If you no longer own this vehicle, please help us update our records. Call the FCA Recall Assistance Center at 1-800-853-1403 to update your information.

[2] You can also mail in your original receipts and proof of payment to the following address for reimbursement consideration: FCA Customer Assistance, P.O. Box 21-8004, Auburn Hills, MI 48321-8007, Attention: Recall Reimbursement.