

**TECHNICAL INSTRUCTIONS**  
**FOR**  
**CUSTOMER SUPPORT PROGRAM 22TE09**  
**HV FLOOR UNDER WIRE HARNESS AND REAR TRACTION MOTOR CABLE**  
**CORROSION**  
**CERTAIN 2019 –2022 MODEL YEAR RAV4 HYBRID AWD**

The repair quality of covered vehicles is extremely important to Toyota. All dealership technicians performing this repair are required to successfully complete the most current version of the E-Learning course “Safety Recall and Service Campaign Essentials”. To ensure that all vehicles have the repair performed correctly; technicians performing this repair are required to currently hold at least one of the following certification levels:

- Hybrid Expert Technician
- Master Technician
- Master Diagnostic Technician

Always check which technicians can perform the recall remedy by logging on to <https://www.uotdealerreports.com>. It is the dealership’s responsibility to select technicians with the above certification level or greater to perform this repair. Carefully review your resources, the technician skill level, and ability before assigning technicians to this repair. It is important to consider technician days off and vacation schedules to ensure there are properly trained technicians available to perform this repair at all times.

## I. OPERATION FLOW CHART

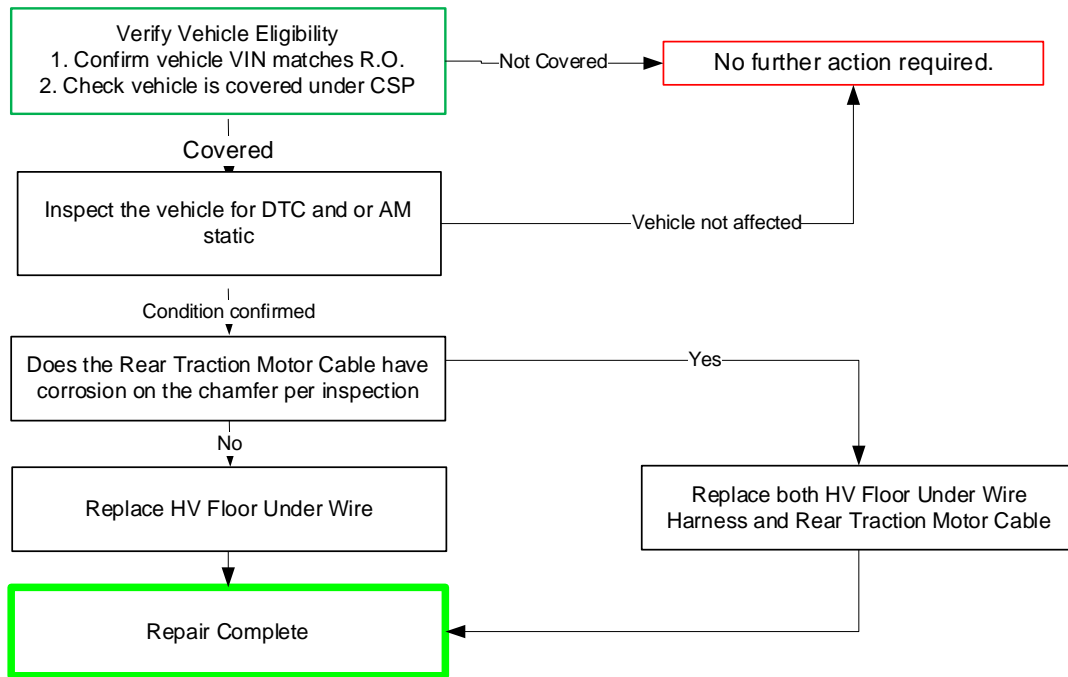

## II. BACKGROUND

Although the HV Floor Under Wire Harness and Rear Traction Motor Cable is covered by Toyota's New Vehicle Limited Warranty for 3 years or 36,000 miles (whichever comes first), we at Toyota care about the customers' ownership experience. Toyota is providing coverage for repairs related to excessive corrosion to the wire harness connections at the Rear Motor Generator. Excessive corrosion can cause AM Radio Static during certain drive cycles or the vehicle may not start.

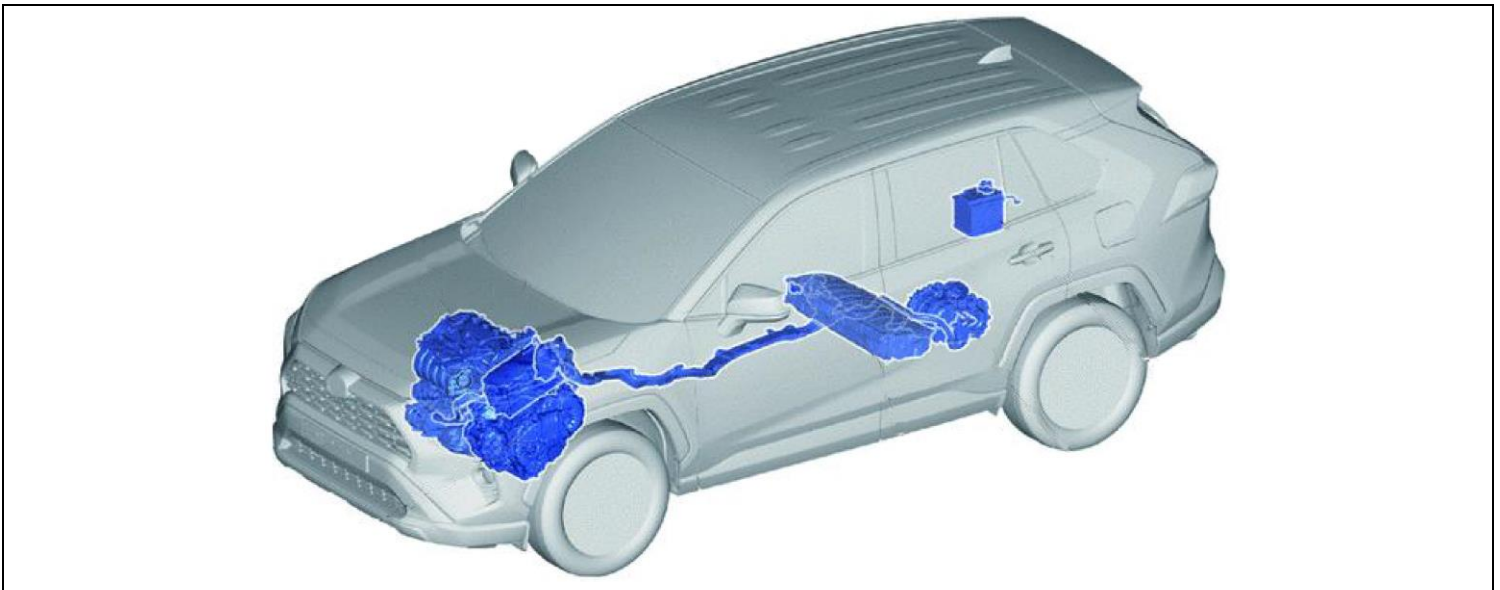

### III. IDENTIFICATION OF AFFECTED VEHICLES

- Check TIS to confirm the VIN is involved in this Customer Support Program
- **TMS warranty will not reimburse dealers for repairs conducted on vehicles that are not affected**

### IV. PREPARATION

#### A. PARTS

**Dealers are not to order parts for stock.**

#### HV Floor Under Wire Harness Repair Parts

NAP Production		
Part Number	Description	Qty
821H1-0R011	HV Floor Under Wire Harness (2019-2021 MY)	1
821H1-0R012	HV Floor Under Wire Harness (2022 MY)	1
72693-06030	Rear Seat Cushion Hook Clips	2
90917-A6002	Gasket, Exhaust Pipe	1
17451-F0100	Gasket, Exhaust Pipe	1
90177-A0021	Nut, Lock	2
90105-A0369	Bolt, Flange	2

CBU Production		
Part Number	Description	Qty
821H1-42021	HV Floor Under Wire Harness (2019-2021 MY)	1
821H1-48131	HV Floor Under Wire Harness (2022 MY)	1
72693-12080	Rear Seat Cushion Hook Clips	2
90917-06094	Gasket, Exhaust Pipe	1
17451-25040	Gasket, Exhaust Pipe	1
90177-10005	Nut, Lock	2
90105-10585	Bolt, Flange	2

**Rear Traction Motor Cable Parts: Only requires replacement based on inspection standard.**

NAP Production		
Part Number	Description	Qty
G1149-42010	Rear Traction Motor Cable	1
G114D-47021	Cap Motor Cable Terminal	1
90105-A0420	Bolt, w Washer	2
90119-A0512	Bolt, W Washer	1

CBU Production		
Part Number	Description	Qty
G1149-42010	Rear Traction Motor Cable	1
G114D-47021	Cap Motor Cable Terminal	1
91552-E1255	Bolt, w Washer	2
90119-14186	Bolt, W Washer	1

#### B. TOOLS & EQUIPMENT

- Techstream
- Basic Hand Tools
- Transmission Jack
- Torque wrench
- Screw Jack
- DVOM

SST- The following tools are essential service tools that all dealers are required to have.

Part Number	Part Description	Quantity
-	Insulated Tools	As needed
01413-00072 (Small)	Insulated Glove Set, Rubber With Leather Protectors*	1
01413-00073 (Medium)		
01413-00074 (Large)		

#### CAUTION

**ALWAYS inspect the insulated gloves before use for cracks, ruptures, tears, pinholes, or damage. Do NOT wear if damaged.**

## V. CONFIRM CONDITION EXISTS AND CABLE INSPECTION

- 1) Perform a health check and confirm if DTC P0AA649 OR P1C8049 are present

YES – Continue to Step 3

NO – Continue to Step 2

**For part release a screen shot is required of DTC from Techstream and the VIN must be in screen shot.**

- 2) Inspect the vehicle for AM static radio interference

- Ready on vehicle
- Change the radio to a known AM station
- After radio is on a known station, place the vehicle into drive or reverse while applying the brake
- Return the vehicle to Park after 3 seconds
- Repeat c and d 3 times

When placing vehicle into drive or reverse is am static introduced each time placed into Drive or Reverse?

YES – Continue to Step 3

NO- This CSP does not apply. Please consult the repair manual and continue diagnosis.

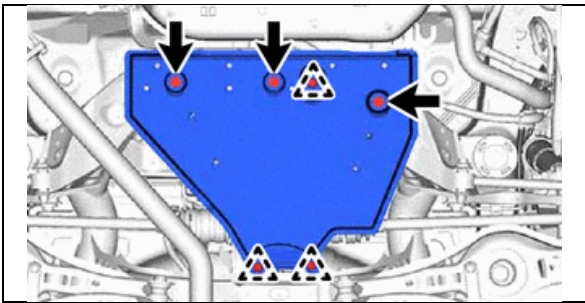

- 3) Remove No. 1 Floor Under Cover

- Remove the 3 bolts, 3 clips and No. 1 floor under cover from the rear suspension member sub-assembly.

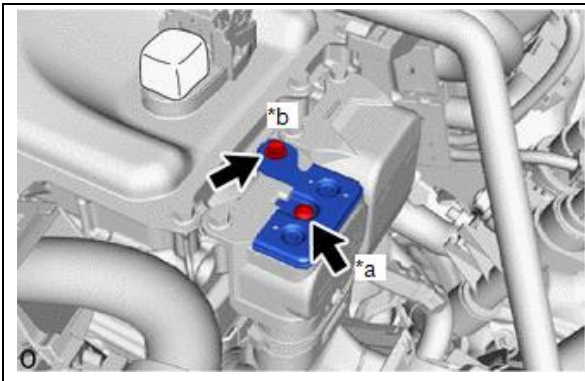

- 4) Disable High Voltage Circuit for Inspection

- Temporarily disconnect 12 v battery
- Remove hybrid service plug
- Remove bolt (B) at inverter as shown.
- Using a T25 "TORX" socket wrench, remove the bolt (A) and connector cover assembly from the inverter with converter assembly.

**NOTICE:**

- Do not touch the connector cover assembly waterproof seal.
- Do not allow any foreign matter or water to enter the inverter with converter assembly.

- Using a voltmeter, measure the voltage between the terminals of the 2 phase connectors.

**Standard Voltage: 0 V**

**NOTICE:** Do not allow any foreign matter or water to enter the inverter with converter assembly.

**HINT:** Use a measuring range of DC 750 V or more on the voltmeter.

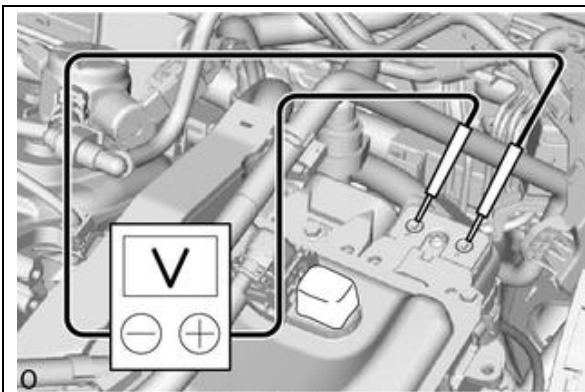

**CAUTION**

Be sure to wear insulated gloves.

**Y6 connector under vehicle at MGR**



- 5) Inspect the Y6 connection for corrosion  
f) Disconnect the Y6 connector at the MGR and inspect for corrosion, dirt, or debris.

**CAUTION**

Orange wire harnesses and connectors indicate high-voltage circuits. To prevent electric shock, always follow the procedure described in the repair manual to disable the high-voltage system.

To prevent electric shock, wear insulated gloves when working on wire harnesses and components of the high-voltage system.

**YES** – Continue to Section VI

**For parts release take photo of connector housing with R.O in picture.**

**NO** - This CSP does not apply. Please consult the repair manual and continue diagnosis.

6) Inspect the connector housing of the MGR.

- a) Inspect the chamfer of the MGR connector housing for pitting and corrosion on the sealing surface. Corrosion in this area will cause the seal to leak. Is pitting and corrosion present?

**YES** – Rear Traction Motor Cable requires replacement continue to Section VI

**Take photo of connector housing with R.O in picture for parts release.**

**NO** – Cable does NOT require replacement continue to Section VI

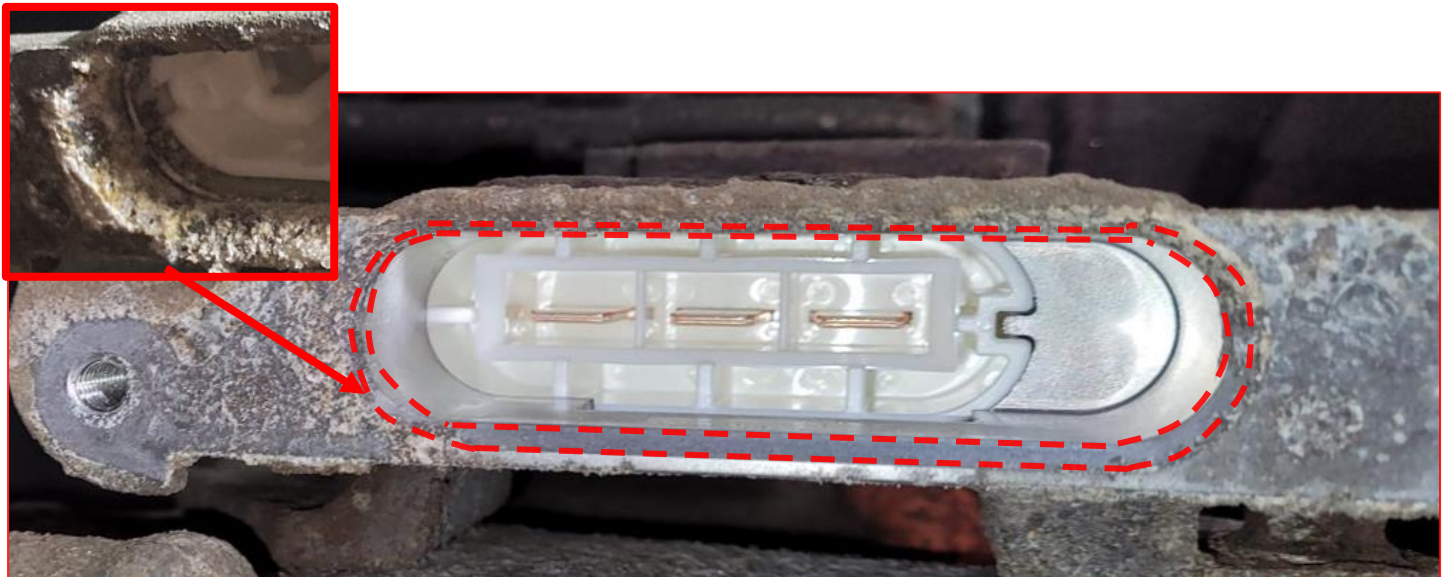



## VI. CABLE REMOVAL PROCEDURE

### A. HV FLOOR UNDER WIRE REMOVAL

1. Remove the HV Floor Under Wire following the repair manual procedure.

Refer to TIS, applicable model and model year Repair Manual:

- [2019](#) / [2020](#) / [2021](#) / [2022](#) RAV4 HV:  
*Engine/Hybrid System – Hybrid/Battery Control System – “Hybrid / Battery Control: Frame Wire: Removal”*

### B. REAR TRACTION MOTOR CABLE REMOVAL (if required, if not required skip to Section VII.B )



1. Disconnect MGR Ground Plug/Sensor (if vehicle is equipped)
  - a) Remove the bolt from the ground and bracket.

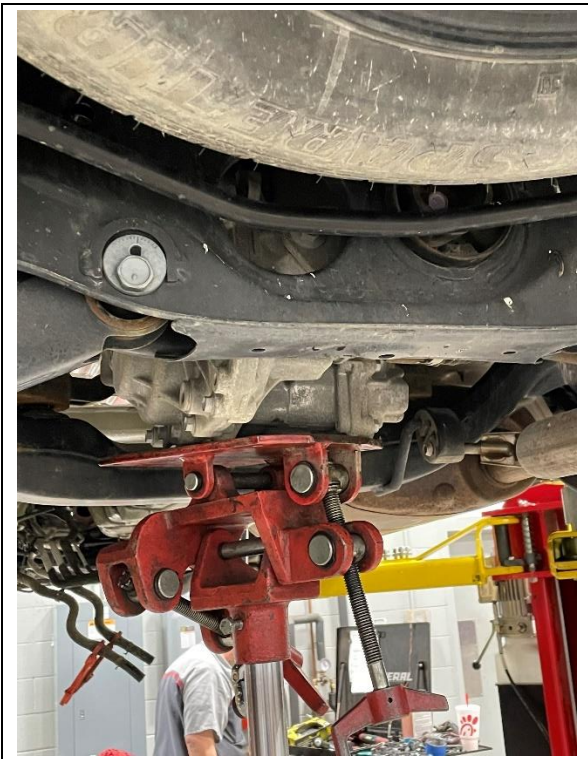

2. Place transmission jack under MGR and secure.

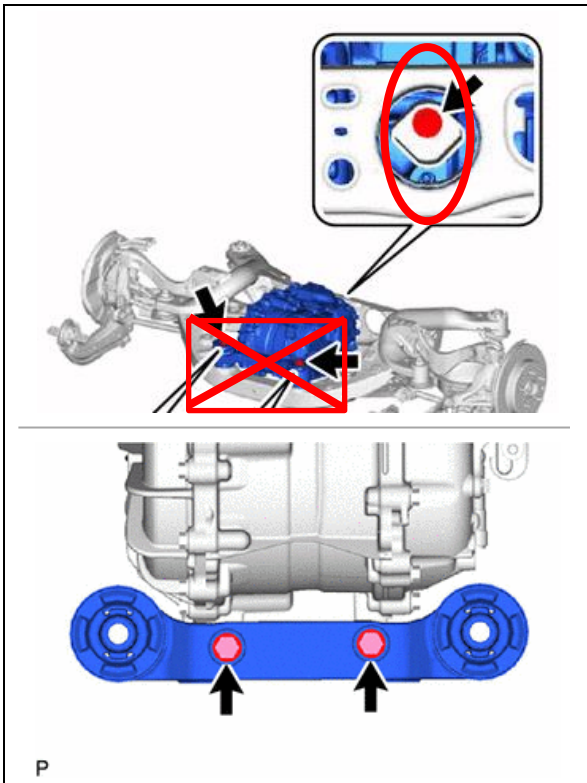

### 3. Remove MGR mounting bolts

- a) Remove MGR rear mount bolt
- b) Remove the front mount inner bolts (**Do not remove outer bolts**)
- c) Slowly tilt the MGR assembly 3 inches to gain clearance with the body. (Do not remove assembly)

#### CAUTION

Do not lower too far to avoid damage to drive shafts.

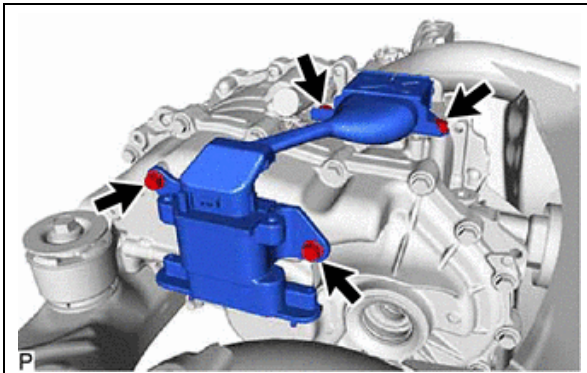

### 4. Remove the Rear Traction Motor Cable side mount bolts.

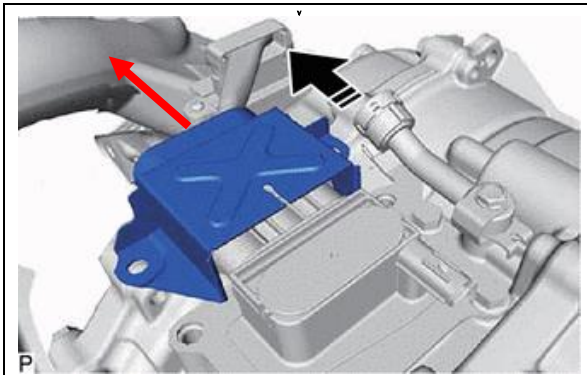

### 5. Remove Motor Cable Terminal Cap (**Non-Reusable**)

- a) Slide the cover on the top side of the rear traction motor cable.
- b) Clean area with shop air and rag around the cover to avoid debris falling in.

#### NOTICE:

- Some vehicles may be extremely dirty in this area, ensure you clean thoroughly before removing cover.

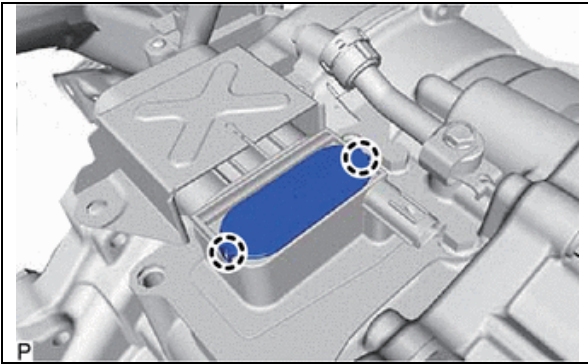

c) Disengage the 2 claws to remove the motor cable terminal cap from the rear traction motor with transaxle assembly.

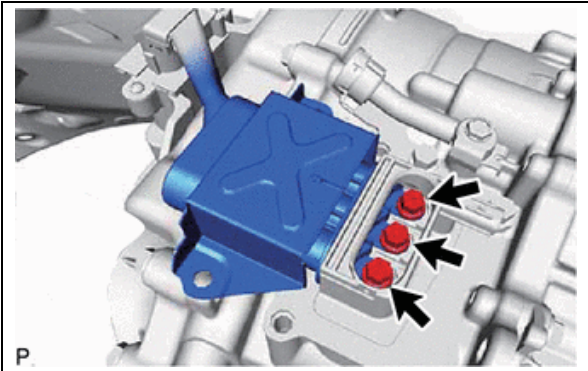

6. **Rear Traction Motor Cable**

a) Remove Rear Traction Motor Cable High Voltage Mount Bolts

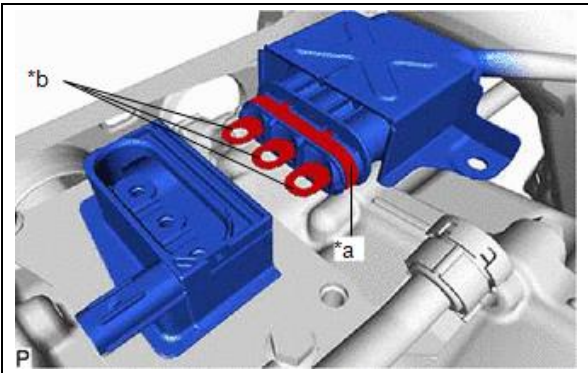

b) Remove Rear Traction Motor Cable from MGR Assembly.



## VII. CABLE INSTALL PROCEDURE

### A. REAR TRACTION MOTOR CABLE INSTALLATION (if required, if not required skip to Section VII. B)

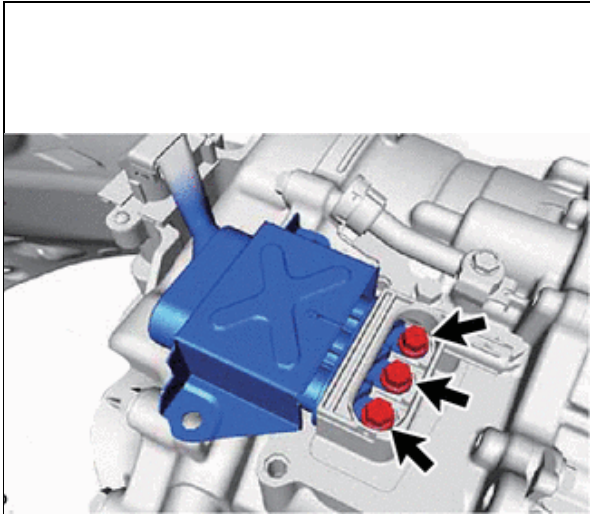

#### 1. Install the Rear Traction Motor Cable onto the MGR

- a) Clean the area around the terminal of the rear traction motor cable, and then blow air on the terminal to remove dust and other foreign matter.

**NOTICE:**

- Blowing air without cleaning first may cause dust and other foreign matter to enter the terminal.
- Dust or other foreign matter entering the terminal when installing the rear traction motor cable may cause a short or electrical leakage.

- b) Using an insulated tool, install the rear traction motor cable to the rear traction motor with transaxle assembly with the 3 bolts.

**Torque:**

10 N·m {102 kgf·cm, 7 ft·lbf}



**Torque is critical at this electrical connection. Ensure this is torqued properly for each bolt.**

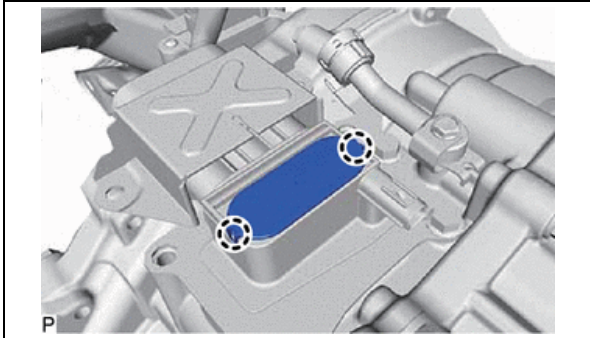

#### 2. Install the new motor cable terminal cap.

- a) Engage the 2 claws to install a new motor cable terminal cap to the rear traction motor with transaxle assembly.

**NOTICE:**

- Do not pinch the O-ring.
- Check that the motor cable terminal cap is securely installed

- b) Slide the cover on the top side of the rear traction motor cable.

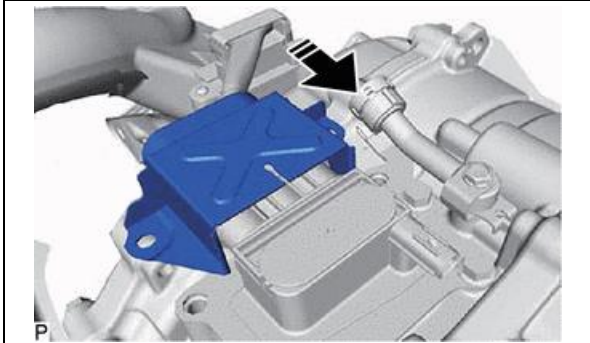

#### 3. Install the 4 bolts for the rear traction motor cable.

**Torque:**

22 N·m {224 kgf·cm, 16 ft·lbf}

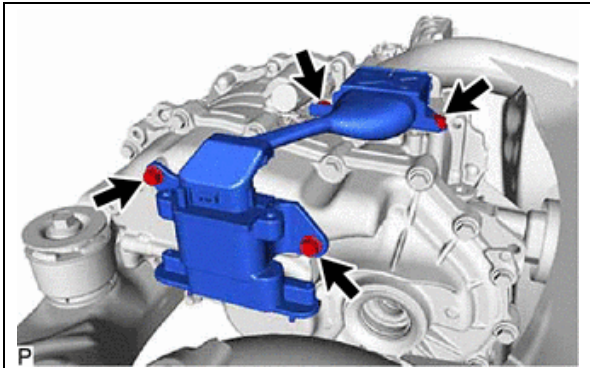

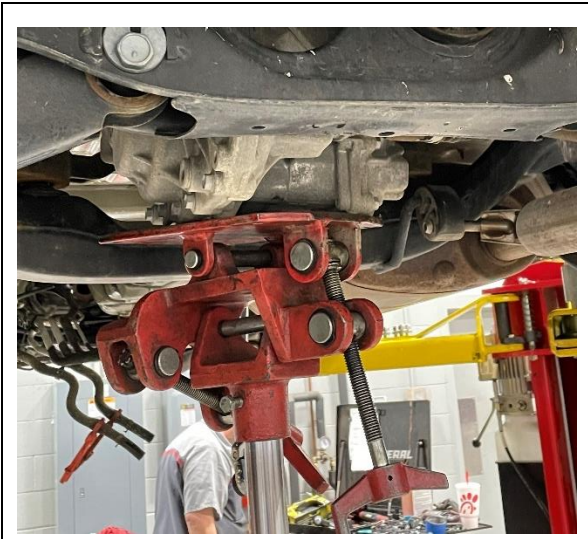

4. Raise the MGR with Transmission Jack

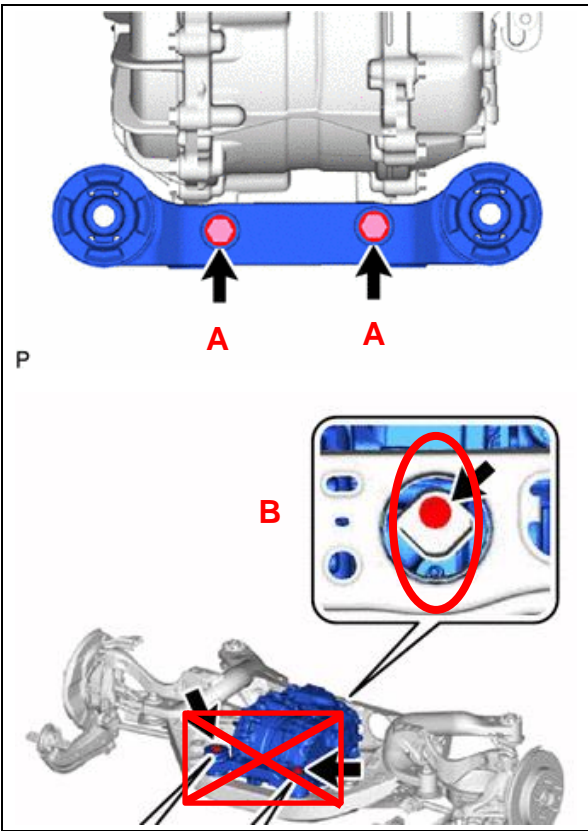

5. Reinstall the MGR mounting bolts.

- a) Temporarily install bolts A and B
- b) Torque bolts to spec starting with A and then moving to B

Torque:

- for bolts A :  
55 N·m {561 kgf·cm, 41 ft·lbf}
- for bolt B :  
130 N·m {1326 kgf·cm, 96 ft·lbf}

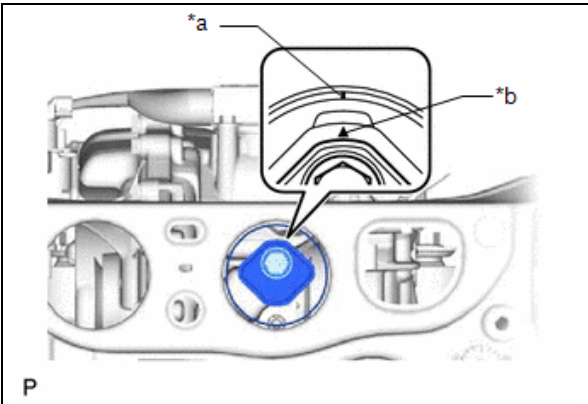

- c) After tightening bolt b, make sure the inner cylinder mark and rubber part mark are positioned as shown.



6. Reinstall MGR Ground Plug/Sensor

- a) Reinstall ground wire to bracket with bolt and torque to spec.

Torque:

10 N·m {102 kgf·cm, 7 ft·lbf}

B. INSTALL THE HV FLOOR UNDER WIRE.

- 1. Install the HV Floor Under Wire following the repair manual procedure.

Refer to TIS, applicable model and model year Repair Manual:

- [2019](#) / [2020](#) / [2021](#) / [2022](#) RAV4 HV:

*Engine/Hybrid System – Hybrid/Battery Control System – “Hybrid / Battery Control: Frame Wire: Installation”*

**NOTICE:** When installing the new HV Floor Under Harness ensure to leave the cover on the wire harness for the inverter connector to protect it during the installation and routing.



- 2. Using Techstream, run a Health Check to verify DTCs P0AA649 and/or P1C8049 are no longer present.
- 3. Test-drive the vehicle to ensure the condition no longer exists and the vehicle exhibits proper operation.

◀ VERIFY REPAIR QUALITY ▶

- Confirm the high voltage bolts are properly torqued to spec.
- Confirm the MGR bolts are torqued to spec and rear mount is properly aligned
- Confirm the cables are properly routed and secured.
- Confirm related DTCs P0AA649 and/or P1C8049 are no longer present

If you have any questions regarding this update, please contact your regional representative.