

Technical Service Bulletin



10 Oil is lost from the filler cap

10 23 25 2059446/6 January 24, 2023. Supersedes Technical Service Bulletin Group 10 number 22-24 dated August 23, 2022, for reasons listed below.

Model(s)	Year	VIN Range	Vehicle-Specific Equipment
A4, S5, S5 Cabriolet, S5 Sportback, A8, SQ5, and Q7	2018 – 2020	All	3.0 TFSI
A6, A7, Q8	2019 – 2020		
A6 allroad, and A8 e quattro	2020		

Condition

REVISION HISTORY		
Revision	Date	Purpose
6	-	Revised <i>Warranty</i> (Updated Labor Operations)
5	08/24/2022	Revised header (Added Model Year)
4	03/08/2021	Revised <i>Warranty</i> (Updated Labor Operations)

Customer states:

- There is oil found in the engine compartment, front end, and around the filler cap.
- There is a smell coming from the engine compartment.

Workshop findings:

There are traces of oil around the filler cap.

Technical Background

A faulty membrane in the breather line can result in excess pressure in the crankcase and therefore some oil is lost through the filler cap.

Production Solution

A breather line with an improved membrane has been implemented in production.



Service

Replace the breather line (different variants available, only order by VIN) by following the Elsa repair manual (Figures 1 and 2).



Figure 1. Breather line for the Turbocharged V6.

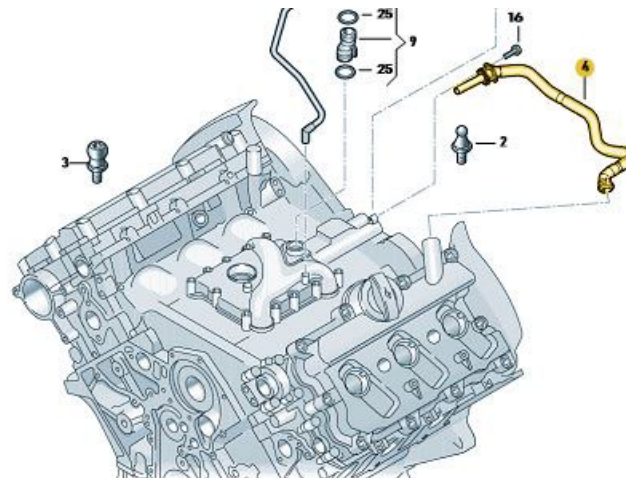

Figure 2. Breather line for the Supercharged V6 (EVO).

Warranty

Claim Type:	<ul style="list-style-type: none">• 110 up to 48 Months/50,000 Miles.• G10 for CPO Covered Vehicles – Verify Owner.• If the vehicle is outside any warranty, this Technical Service Bulletin is informational only.
Service Number:	1050

Technical Service Bulletin



Damage Code:	0050		
Labor Operations:	Remove + install crankcase breather hose	2446 1943 (V6 Turbo) Only	See SRT with associated operations
	Remove + install crankcase breather hose	1052 1999 (EVO) Only	30 TU
	Clean (If required)	1052 2999 (All Models)	5 TU
Diagnostic Time:	GFF	No allowance	0 TU
	Road test prior to the service procedure	No allowance	0 TU
	Road test after the service procedure	No allowance	0 TU
Claim Comment:	As per TSB 2059446/6		

All warranty claims submitted for payment must be in accordance with the *Audi Warranty Policies and Procedures Manual*. Claims are subject to review or audit by Audi Warranty.

Required Parts and Tools

Always check with your Parts Department and/or ETKA for the latest information and parts bulletins.		
Part Number	Part Description	Quantity
See ETKA	Fasteners, Bolts, Nuts, and Screws as needed per the Repair Manual	See ETKA/ELSA
Order by VIN	Breather Line	01

Additional Information

All parts and service references provided in this TSB (**2059446**) are subject to change and/or removal. ©2023 Audi of America, Inc. All rights reserved. The information contained in this document is based on the latest information available at the time of printing and is subject to the copyright and other intellectual property rights of Audi of America, Inc., its affiliated companies, and its licensors. All rights are reserved to make changes at any time without notice. No part of this document may be reproduced, stored in a retrieval system, or transmitted in any form or by any means, electronic, mechanical, photocopying, recording, or otherwise, nor may these materials be modified or reposted to other sites, without the prior expressed written permission of the publisher.