

GLOBAL SAFETY FIELD INVESTIGATIONS
DCS6457
URGENT - DISTRIBUTE IMMEDIATELY

Date: February 21, 2023

Subject: N222390510 - Service Update
Body Control Module Connectors

Models: 2023 Cadillac XT4
2023 Chevrolet Malibu

To: All General Motors Dealers

General Motors is releasing Service Update N222390510 today. The total number of U.S. vehicles involved is approximately 443. Please see the attached bulletin for details.

Global Warranty Management (GWM)

The Required Field Action section on the Investigate Vehicle History (IVH) screen will be updated February 21, 2023. A list of vehicles in dealer inventory is attached to this message. Please hold all warranty transactions until IVH has been updated.

END OF MESSAGE

GLOBAL SAFETY FIELD INVESTIGATIONS

Service Update

N222390510 Body Control Module Connectors



Release Date: February 2023

Revision: 00

Attention: This service update includes vehicles in dealer inventory and customer vehicles that return to the dealership for any reason. This bulletin will expire at the end of the involved vehicle's New Vehicle Limited Warranty period.

Make	Model	Model Year		RPO	Description
		From	To		
Cadillac	XT4	2023	2023		
Chevrolet	Malibu				

Involved vehicles are marked "Open" on the Investigate Vehicle History screen in GM Global Warranty Management system. This site should always be checked to confirm vehicle involvement prior to beginning any required inspections and/or repairs.

Condition	Certain 2023 model year Cadillac XT4 and Chevrolet Malibu vehicles may have a condition where one or more of the body control module connectors are not fully seated.
Correction	Dealers are to inspect the connectors at the body control module and ensure they are all fully seated.

Parts

No parts are required for this repair.

Warranty Information

Labor Operation	Description	Labor Time	Trans. Type	Net Item
9106626	Verify BCM Connector Engagement: Malibu XT4	0.3 0.4	ZFAT	N/A

Service Procedure

1. Determine vehicle make and model.
 - If vehicle is a Malibu, proceed to step 2.
 - If vehicle is a XT4, proceed to step 3.

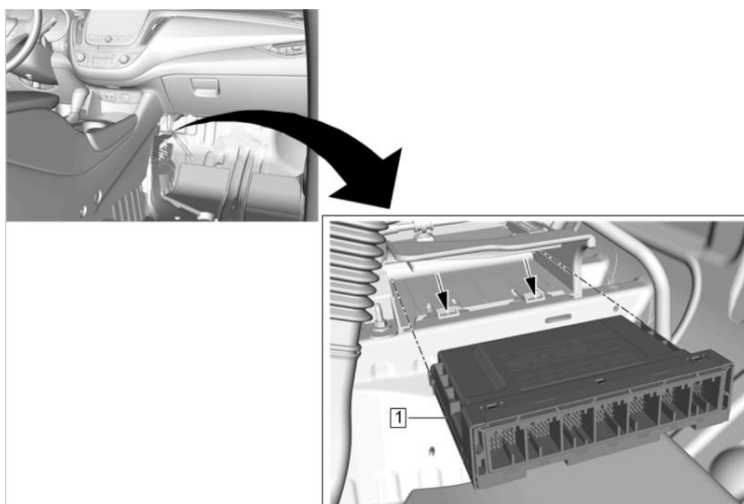

4213275

2. Pull the passenger's side front carpet back to access the Body Control Module (1). Proceed to step 8.
3. Move the passenger side front seat to the full rearward position.

Service Update

N222390510 Body Control Module Connectors

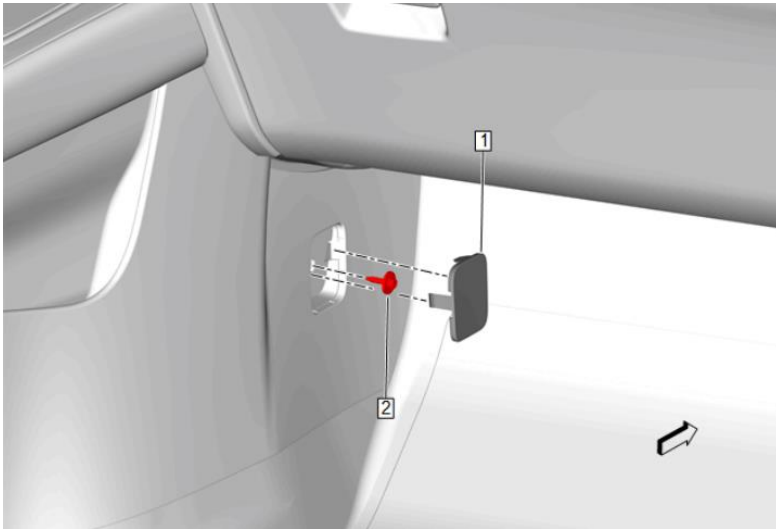

5053764

4. Remove the Front Floor Console Extension Panel Bolt Access Hole Cover (1).
5. Remove the Front Floor Console Extension Bolt (2).

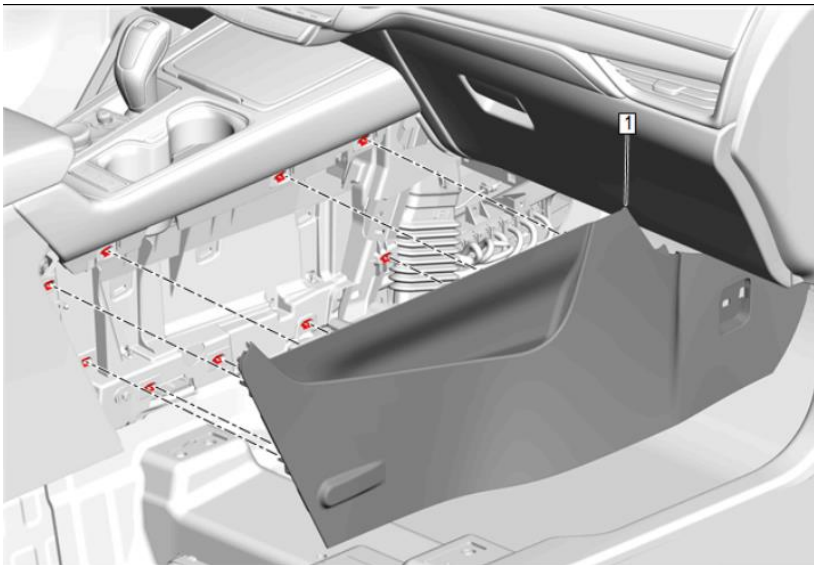

5053765

6. Using a flat-bladed plastic trim tool, release the retaining clips.
7. Remove the Front Floor Console Extension Panel – Right Side (1).

Service Update

N222390510 Body Control Module Connectors

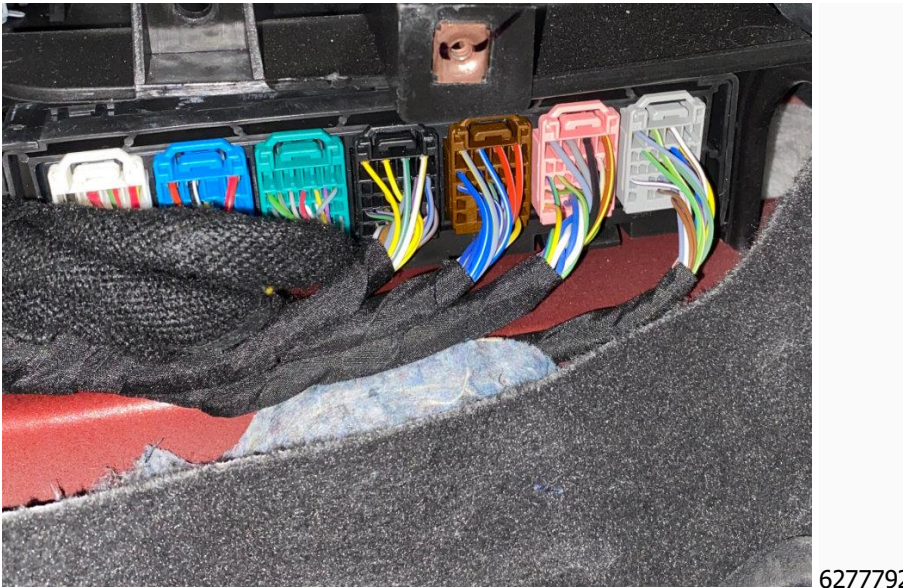

6277792

Caution: Do not pull on the wires of the connector to ensure engagement, only pull on the connector housings.

8. Verify all of the connectors are fully engaged by slightly pulling on the connectors in the direction of removal.
9. Ensure all of the connectors are fully pushed into the Body Control Module by pushing on the connector housings in the direction of installation.
 - If vehicle is a Malibu, proceed to step 10.
 - If vehicle is a XT4, proceed to step 11.

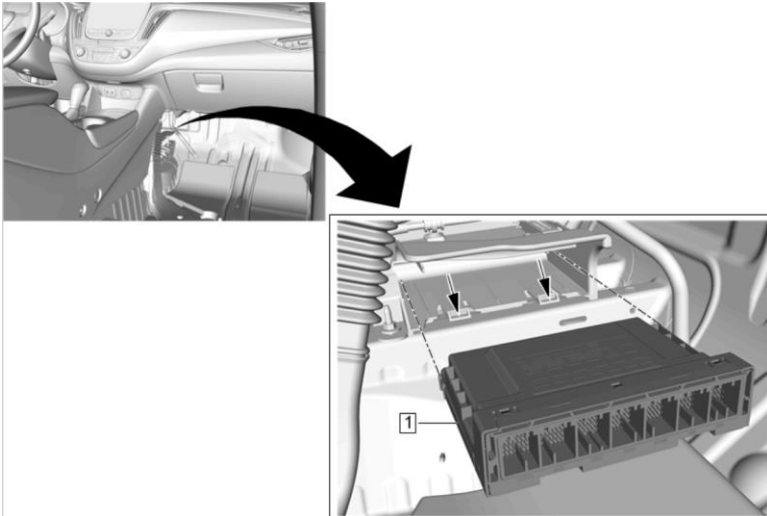

4213275

10. Reinstall the passenger's side front carpet to the original location, no further action is required.

Service Update N222390510 Body Control Module Connectors

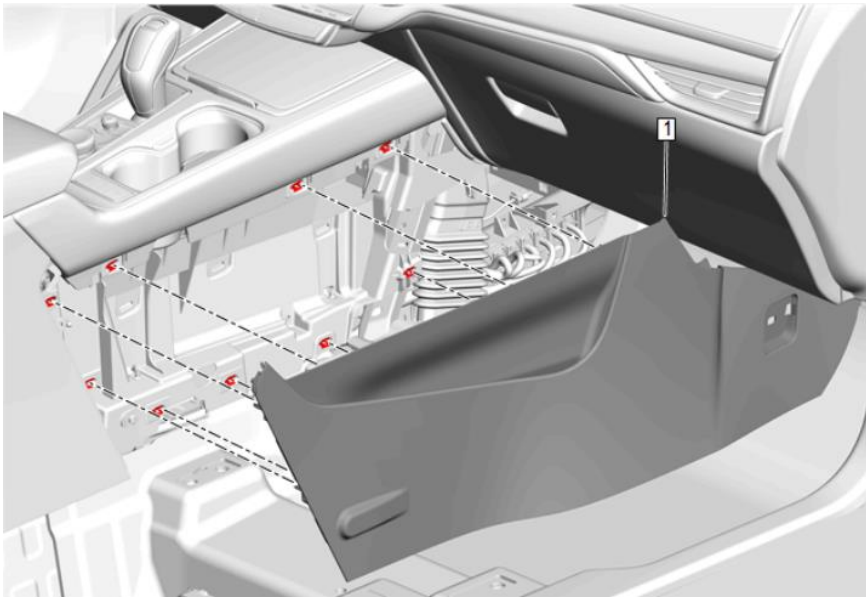

5053765

11. Install the Front Floor Console Extension Panel – Right Side (1).

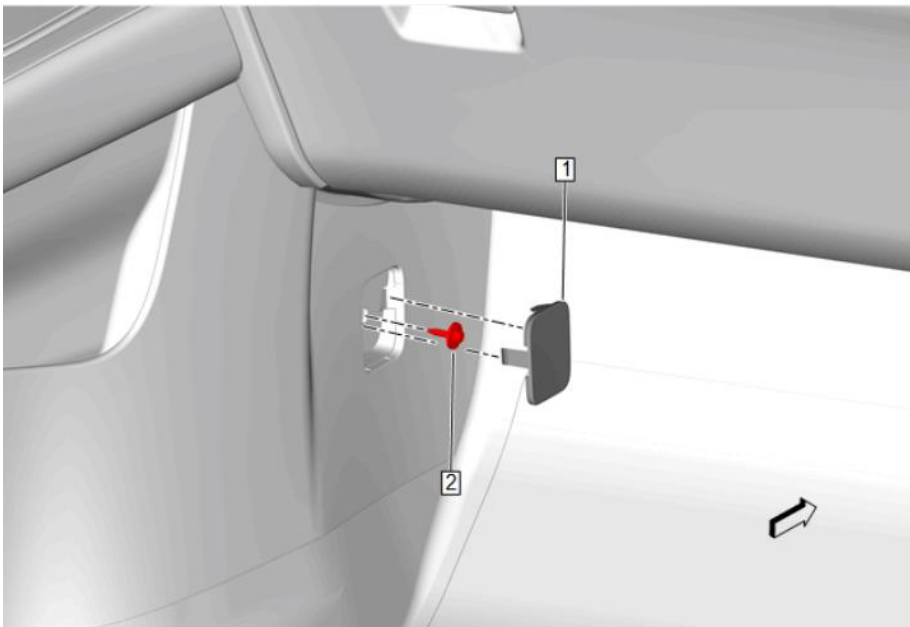

5053764

12. Install and tighten the Front Floor Console Extension Bolt (2) to 2.5 Nm (22 lb in).
13. Install the Front Floor Console Extension Panel Bolt Access Hole Cover (1).

Dealer Responsibility

Whenever a vehicle subject to this service update enters your vehicle inventory or is in your facility for service in the future, and the vehicle is still covered under the New Vehicle Limited Warranty, you must take the steps necessary to be sure the service update correction has been made before selling or releasing the vehicle.

All new, used, GM Certified Used, courtesy transportation vehicles, dealer shuttle vehicles, etc. in dealers' possession and subject to this bulletin must be held and inspected/repaired per the service procedure of this bulletin before customers take possession of these vehicles. Involved vehicles must be held and not delivered to customers, dealer-traded, released to auction, used for demonstration, or any other purpose.

All GM Certified Used vehicles currently in the dealers' inventory within the Certified Pre-Owned Inventory System (CPOIS) will be de-certified and must be held and remedied per the service procedure in this bulletin. Upon submitting

Service Update

N222390510 Body Control Module Connectors



an accepted/paid warranty transaction in the Global Warranty Management (GWM) system, the vehicle can be re-certified for sale within the CPOIS system, or once again be used in the CTP program.

Dealer Reports – For USA & Export

The Inventory tab of the Open Vehicle Report will contain Service Update Bulletin VINs that apply to this field action. This information is intended to assist dealers with the **PROMPT COMPLETION** of these vehicles. The Customer In-Service tab will not contain Service Update Bulletin VIN data because the intent of a Service Update Bulletin is to not inconvenience a customer with a special trip for service. Service Update Bulletins are to be completed when the customer is in for a regularly scheduled visit.

GM bulletins are intended for use by professional technicians, NOT a "do-it-yourselfer". They are written to inform these technicians of conditions that may occur on some vehicles, or to provide information that could assist in the proper service of a vehicle. Properly trained technicians have the tools, equipment, safety instructions, and know-how to do a job properly and safely. If a condition is described, **DO NOT** assume that the bulletin applies to your vehicle, or that your vehicle will have that condition. See your dealer for information on whether your vehicle may benefit from the information.



**We Support
Voluntary Technician
Certification**