

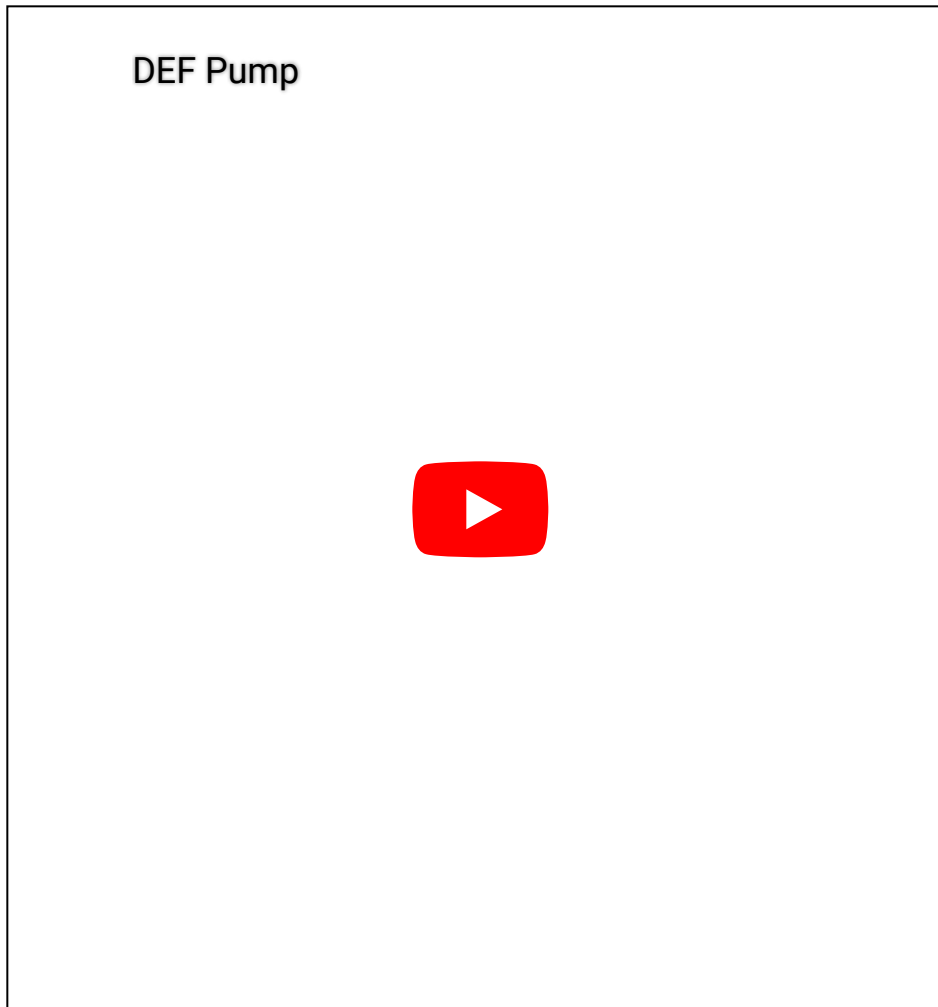

Mack DEF Pump Troubleshooting Guide - US10+OBD13 And Newer Emissions



Component Overview



The Diesel Exhaust Fluid (DEF) Pump's function is to build and regulate the DEF systems pressure that is supplied to the dosing valve. The DEF Pump is a multi-unit component that consists of:

- Mechanical pump
- Reverting valve
- Pressure sensor
- Main filter
- Fluid connectors (2 coolant & 3 DEF)
- Electrical connector

The DEF Pump is controlled by the After-Treatment Control Module (ACM). On every key cycle, the sensors and actuators in the DEF dosing system perform a self-check for proper operation. When the truck is turned off, the ACM uses a temperature based delayed reverting/draining strategy to pump the DEF back into the tank.

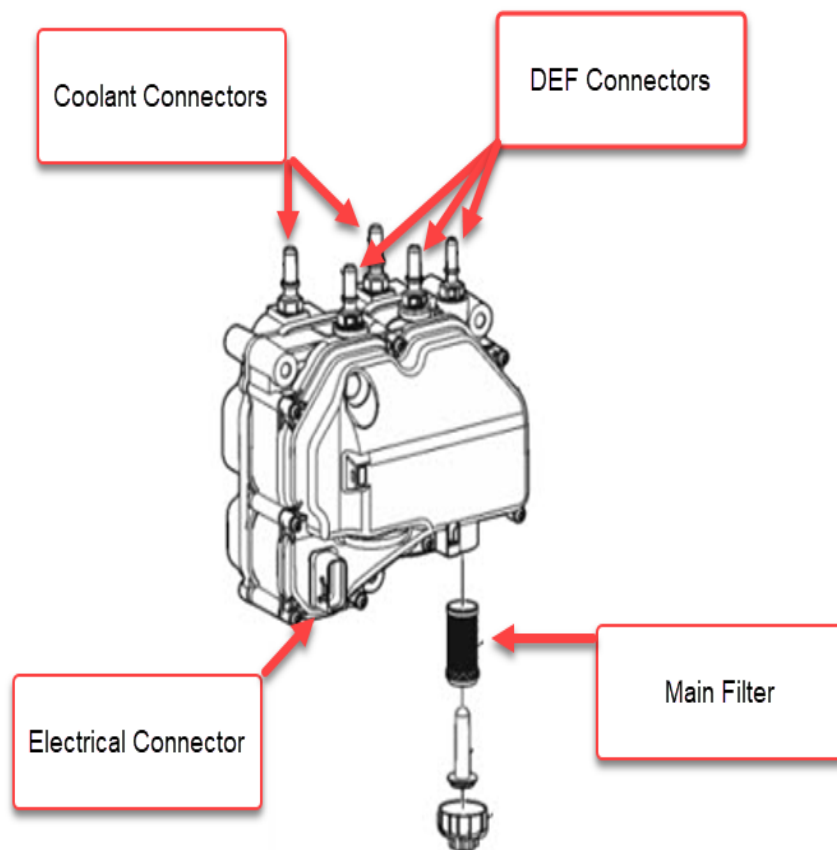

The primary failure mode of the DEF Pump is:

- Leak - externally leaking fluid
- Internal Failure - which will generate a specific DTC

Diagnose and Repair

NOTE: a large amount of DEF Pumps returned through warranty have

Live UI tested and determined to have No Fault Found. It is extremely

important to not replace the DEF Pump unnecessarily but to determine the root cause of the failure.

Leaking DEF

Not all leaks at the DEF pump require replacement of the pump assembly. It is imperative to determine the location of the leak.

1. Clean the suspected area using a suitable solvent.
2. Run PTT Option **2589-08-03-05 Subtest A** to pressurize the system.
3. Inspect the affected area to determine the location of the leak using the table below.

Location of Leak	Direction
Fluid Connectors	Repair or Replace fitting and/or hose
Filter Assembly	Replace Filter Assembly
Electrical Connector	Replace Pump and Harness
Pump splitting	Replace Pump

Internal Failure of the Pump

All internal pump failures will generate a specific Diagnostic Trouble Code (DTC)

Perform a DTC Readout using Premium Tech Tool. Review the tables below to determine which category the Fault Code currently being diagnosed falls under. Proceed according to the directions for the appropriate section.

Under Pressure Faults

DTC	Description
P20E8-92	Reductant Pressure Too Low, Incorrect Operation
P202D-00	Aftertreatment Reagent Pressure Leakage
P20BA-00	Reductant Heater A control Performance

Directions:

1. Inspect def tank for frozen fluid, debris, or low level.

 Live UI

2. Disconnect the supply line at the DEF Pump.

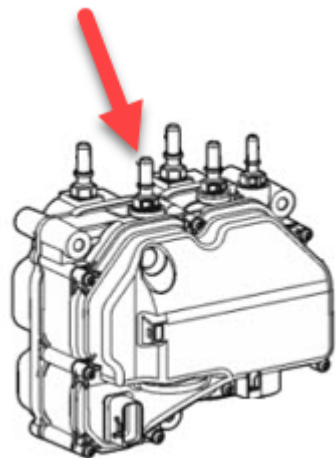

3. Connect a clear 3/8" (inner diameter) hose to the fitting and place the other end of the hose into the DEF Tank.

- **Note:** This will require removal of DEF Tank Filler Neck Insert (Impact **2589-03-02-42**).

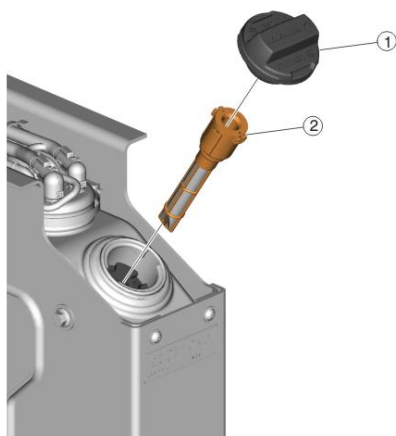

4. Run Pressure Build Up Operation in PTT **2589-08-03-05 Selection A**. Ensure the DEF Pump is running (audible noise) and allow to run for at least 5 minutes.

5. Evaluate results:

- **If the system is not able to build pressure:** Replace the inlet fitting (which contains a screen, which could be blocked). Re-run evaluate. If the pump is still not able to build pressure, Replace the DEF Pump in accordance with Impact operation **2581-03-02-01** .

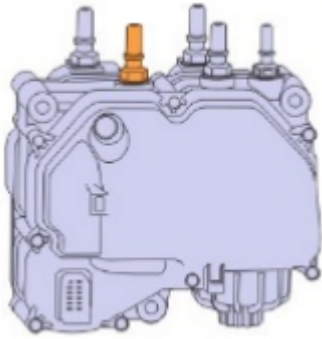

• **If the system is able to build pressure:** The pump is not the issue. Further diagnosis is needed for the supply side of the system. Inspect the below components and repair as necessary:

- **DEF Tank Vent** - make sure the vent is clean and free of debris.

○ **NOTE:** Do NOT blow air through the line, as this will likely introduce debris into the DEF Tank.

- **Lines Blockage from DEF Tank to Pump.**

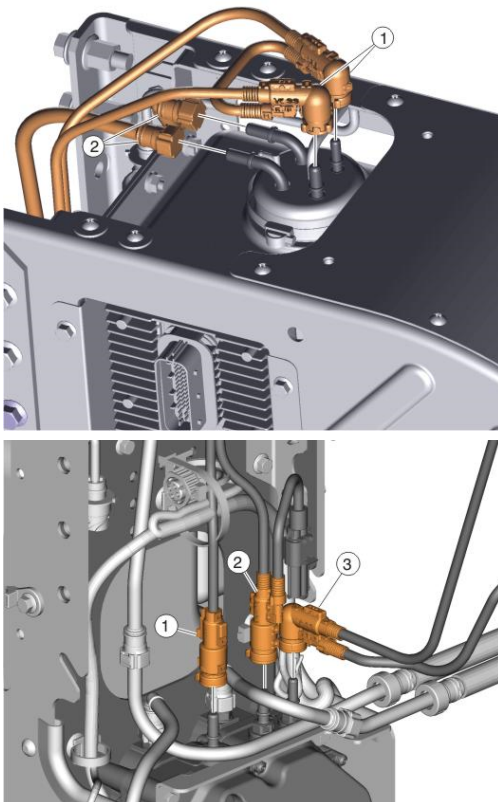

- **Blocked/damaged Tank Screen or pickup tube.**

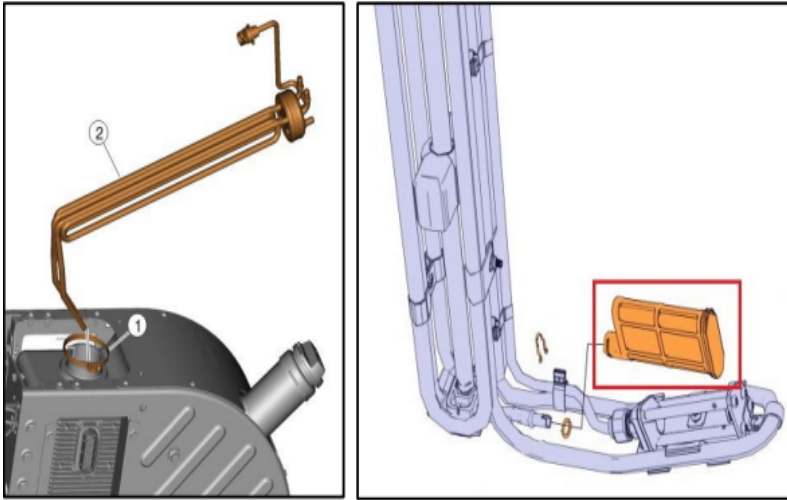

Over Pressure Faults - only diagnose active DTCs.

DTC	Description
P208B-00	Reductant Pump "A" Control Performance/Stuck Off
P10CE-97	Reductant Return No Flow Detected
P20A1-07	Aftertreatment Reagent Direction Valve Mechanical Problem

Directions:

1. Inspect def tank for frozen fluid or debris.
2. Replace return line fitting (this fitting contains a return orifice).

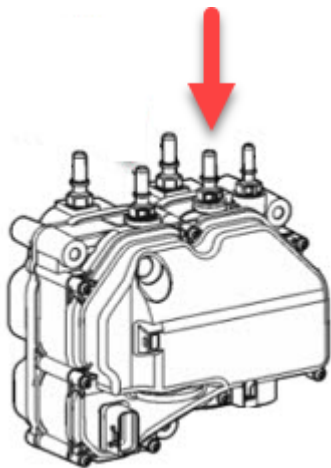

3. Run Pressure Build Up Operation in PTT **2589-08-03-05 Selection A.**

Live UI [uate the results](#)

- **If the DEF Pump builds pressure and does not shut down for 5 minutes:** Clear the faults and release the vehicle.
- **If the DEF Pump over pressures and stops running (DTC will log again):**
 - a. Check return line (from DEF Pump to DEF Tank) for blockage and replace as necessary.
 - b. Re-run the evaluation. If the pump continues to overpressure, replace the pump in accordance with Impact operation **2581-03-02-01**.

Electrical Faults - only diagnose active or confirmed DTCs

DTC	Description
P20A0-13	Reductant Purge Control Valve, Open Circuit
P10AD-13	Reductant Pump "A" Control Low Side, Open Circuit
P204A-13	Reductant Pressure Sensor, Open Circuit
P208A-13	Reductant Pump "A" Control, Open Circuit
P208C-00	Aftertreatment Reagent Pump Control Short Circuit Low
P20A2-00	Aftertreatment Reagent Direction Valve Short Circuit Low
P204C-00	Aftertreatment Reagent Pressure Sensor Circuit Low
P10AF-00	Reductant Pump "A" Control Low Side Circuit High
P204B-64	Aftertreatment Reagent Pump Orifice Blocked
P10AE-00	Reductant Pump "A" Control Low Side Circuit Low
P208D-00	Aftertreatment Reagent Pump Control Short Circuit High
P20A3-00	Aftertreatment Reagent Direction Valve Short Circuit High

Directions: all of the above codes will cause the DEF Pump to discontinue operation until code is corrected. Inspect electrical circuits using PTT Diagnostics to identify the electrical issue.

NOTE: For trucks operating in a dirty or harsh environment and experiencing repeat DEF Pump Failures see Technical Service Bulletin (TSB) **Aftertreatment Diesel Exhaust Fluid (DEF) Tank Vent Filter, New Installation**.

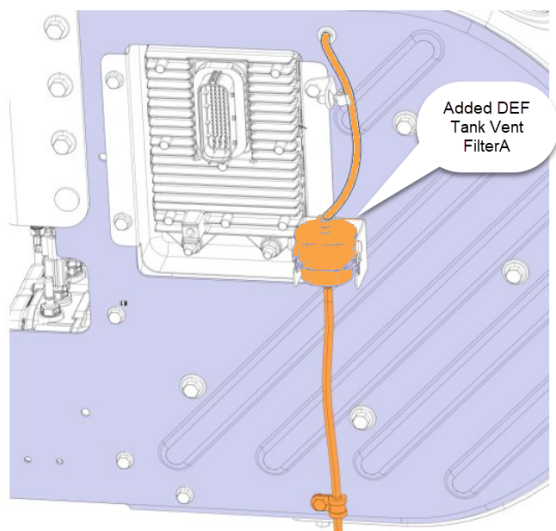

Rules for Replacement

Warranty will only cover replacement of the DEF Pump if:

- Leak is identified as unreparable (leaks at fittings or main filter are repairable), these pumps may require parts returned for analysis.
- Fault codes in the Yellow sections above is active or confirmed.

In addition, if the DEF Pump is being replaced. Maintenance records will be required showing the cleaning of the DEF Tank and Filter Change have been properly maintained and are not the root cause of the failure.

Refer to Service At a Glance (SAG) found in the Trucks Dealer Portal under the Information tab - Service - Service literature for replacement and cleaning intervals of the DEF Tank & Filters.

Standard Diagnostic Time 1.0 hrs

Diagnostic Trouble Codes With DEF/Urea in the Description

Direction/Repair: DO NOT REPLACE the DEF Pump for these codes. Diagnostics should be performed using PTT Diagnostics and the comment section in the table below.

DTC	Description	Probable Source
P2042-01	Reductant Temperature Sensor, Electrical Failure	Temperature - Check wiring harness CBR-2015
P21CA-00	Reductant Control Module Supply Voltage	Check ACM Power Supply CBR-2040
P2043-64	Aftertreatment Reagent Tank Temperature Sensor Stuck, Signal plausibility failure	TBD

 Tags

[p2042-01](#) [p20a3-00](#) [p208d-00](#) [p10ae-00](#)
[def pump](#) [def tank](#) [def filter](#) [p21ca-00](#)
[p204b-64](#) [p10af-00](#) [p204c-00](#) [p20a2-00](#)
[p208c-00](#) [p208a-13](#) [p10ce-97](#) [p20a1-07](#)
[p20e8-92](#) [p202d-00](#) [p20ba-00](#) [p204a-13](#)
[p10ad-13](#) [p20a0-13](#) [p208b-00](#) [unlocking uptime](#)
[mack](#) [p2043-64](#)

Categories 

Make and Model > Mack > CXU/CHU/PI - Pinnacle

Make and Model > Mack > LEU - TerraPro Low Entry

Make and Model > Mack > LR

Make and Model > Mack > TD - Titan

Make and Model > Mack > MRU/TE - TerraPro

Vehicle System > Emissions

Make and Model > Mack > AN - Anthem

Make and Model > Mack > GU/GR - Granite

Related links and attachments

[KC-2165 2581-03-02-01](#)

[KC-2165 2589-03-02-42](#)

[KC-2165 2589-08-03-05 IMG 1](#)

[KC-2165 2589-08-03-05 IMG 2](#)

[KC-2165 2589-08-03-05 IMG 3](#)



Feedback

[Give feedback](#)

to help improve the content of this article

25807-2 Aftertreatment Diesel Exhaust Fluid (DEF) Pump Unit, Replacement

You must read and understand the precautions and guidelines in Service Information, group 20, "General Safety Practices, Engine" before performing this procedure. If you are not properly trained and certified in this procedure, ask your supervisor for training before you perform it.

Removal

- 1
Apply parking brake and place shift lever in neutral.
- 2
Remove all cables from ground (negative) battery terminals to prevent personal injury from electrical shock and prevent damage to electrical components.
- 3
If equipped, remove the side fairing covering the Diesel Exhaust Fluid (DEF) tank.

4

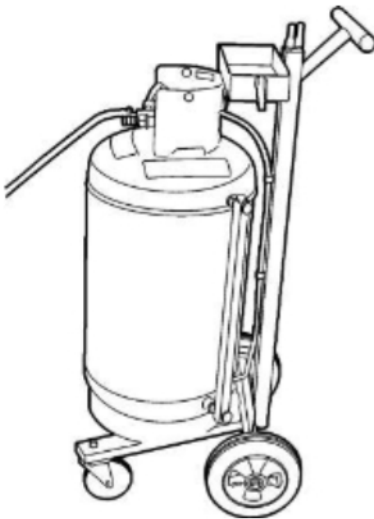

Connect the coolant extractor to the drain fitting at the bottom of the radiator and drain the coolant.

Note: An alternate method is to connect the coolant drain hose to the drain fitting and drain the coolant into a suitable container.



Danger

Coolant is toxic; risk of poisoning. Do not drink coolant. Use proper hand protection when handling. Keep coolant out of reach of children and animals. Failure to follow these precautions can cause serious illness or death.

Special tools: [DBT2V700](#), [9996049](#)

5

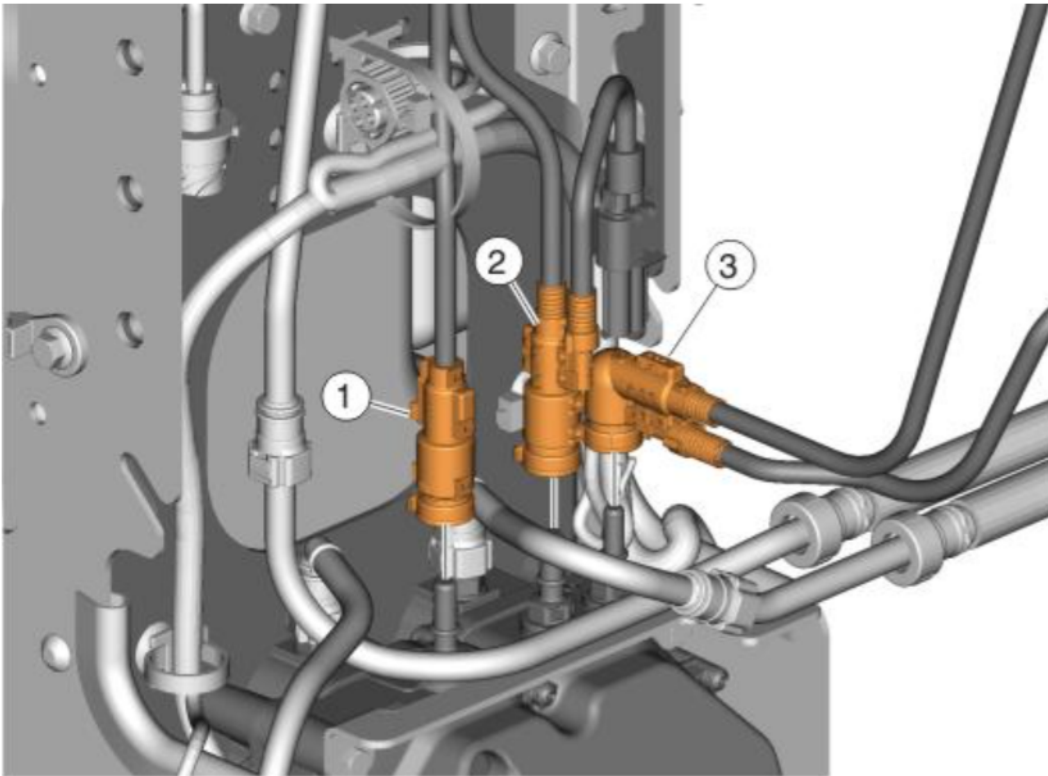

1. DEF Inlet Line
2. DEF Backflow Line
3. DEF Outlet Line

Note: For information on the handling of DEF, refer to "General Safety Practices", Group 20.

Note: If inlet and backflow lines are switched, the system will not start.

Mark the DEF lines before removal. Place a suitable container under the DEF tank to catch fluid that may drain from the pump. Remove the DEF inlet, backflow and outlet lines from the pump.

6

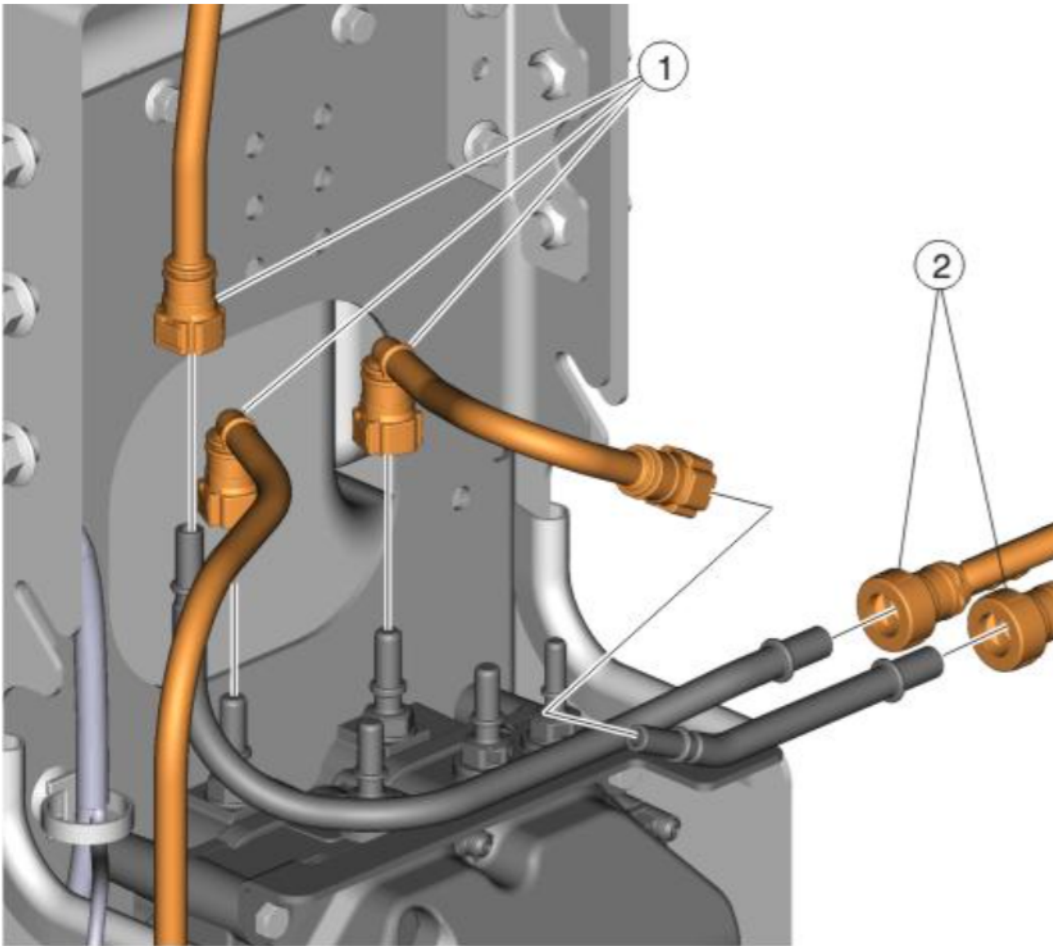

1. Inlet Coolant Lines
2. Outlet Coolant Lines

Remove the inlet and outlet coolant lines from the pump. Place protective caps on the DEF and coolant connectors.

7

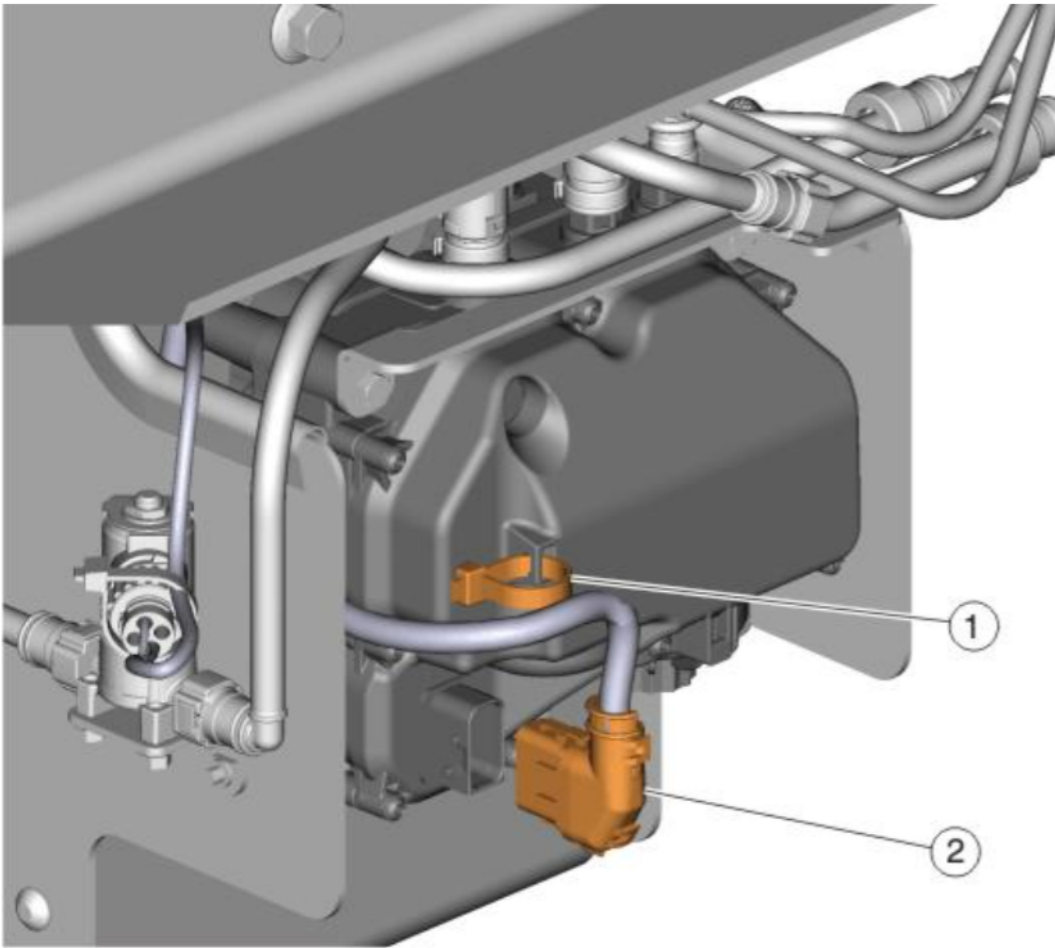

- 1. Cable Tie
- 2. Wiring Harness

Remove cable tie and disconnect the wiring harness from the DEF pump. Cover the electrical connector with a plastic bag to protect from possible damage from the DEF.

8

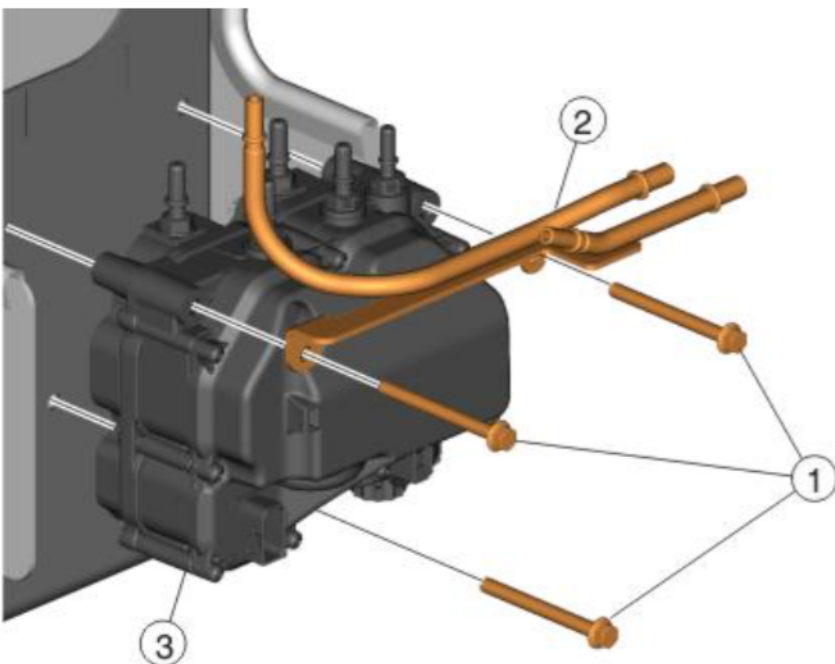

1. Fasteners
2. Bracket
3. DEF Pump

Remove the DEF pump from the tank by removing the fasteners along with the bracket.

Installation

1

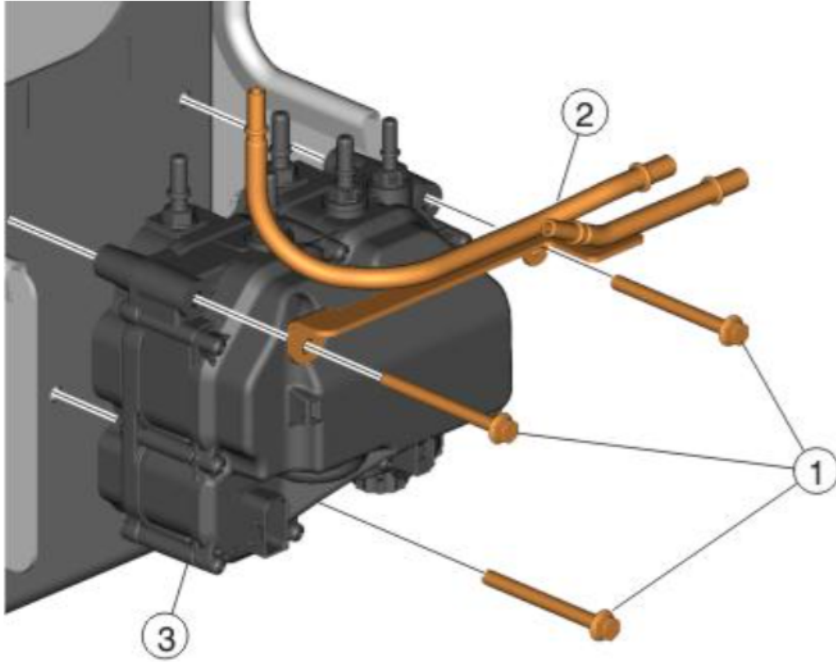

1. Fasteners
2. Bracket
3. DEF Pump

Install fasteners to attach bracket and the DEF pump onto the tank. Tighten the fasteners to specification. Refer to Specifications in Group 20.

2

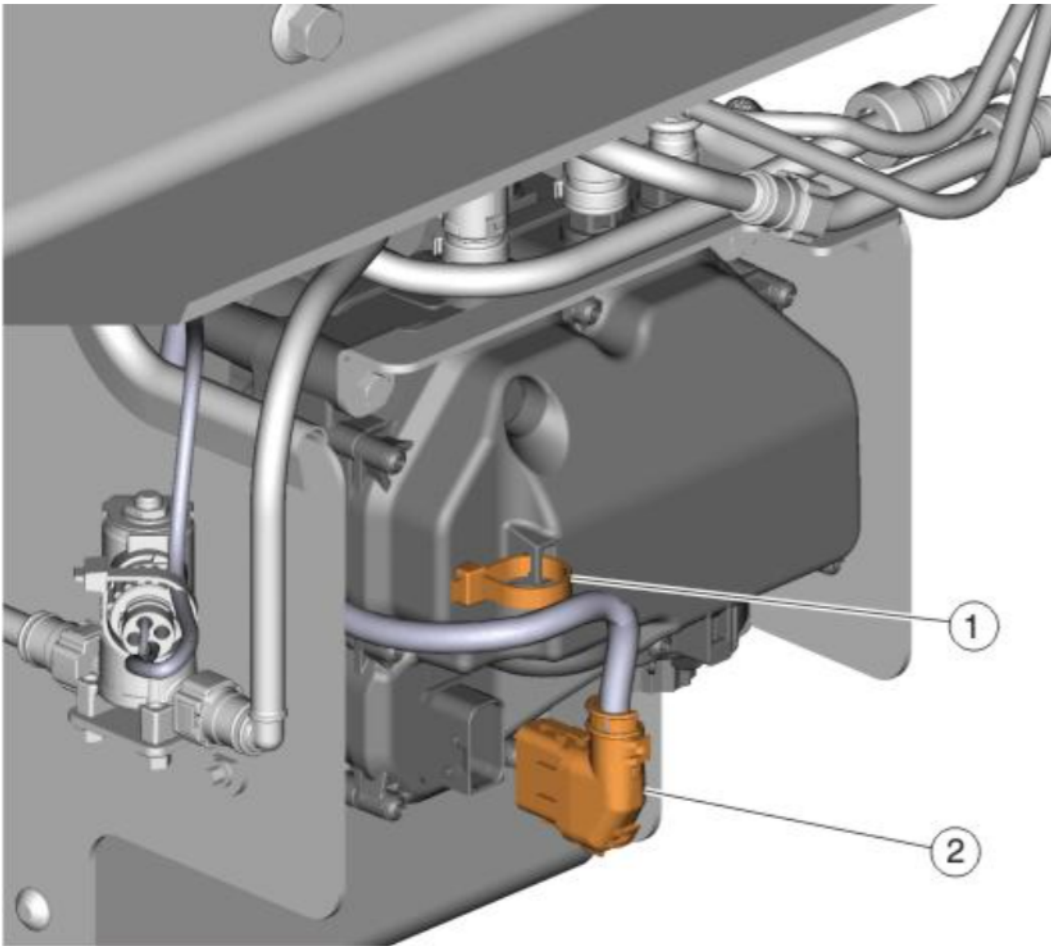

1. Cable Tie
2. Wiring Harness

Remove plastic bag from the electrical connector. Connect the wiring harness to the DEF pump and secure the harness using a cable tie.

3

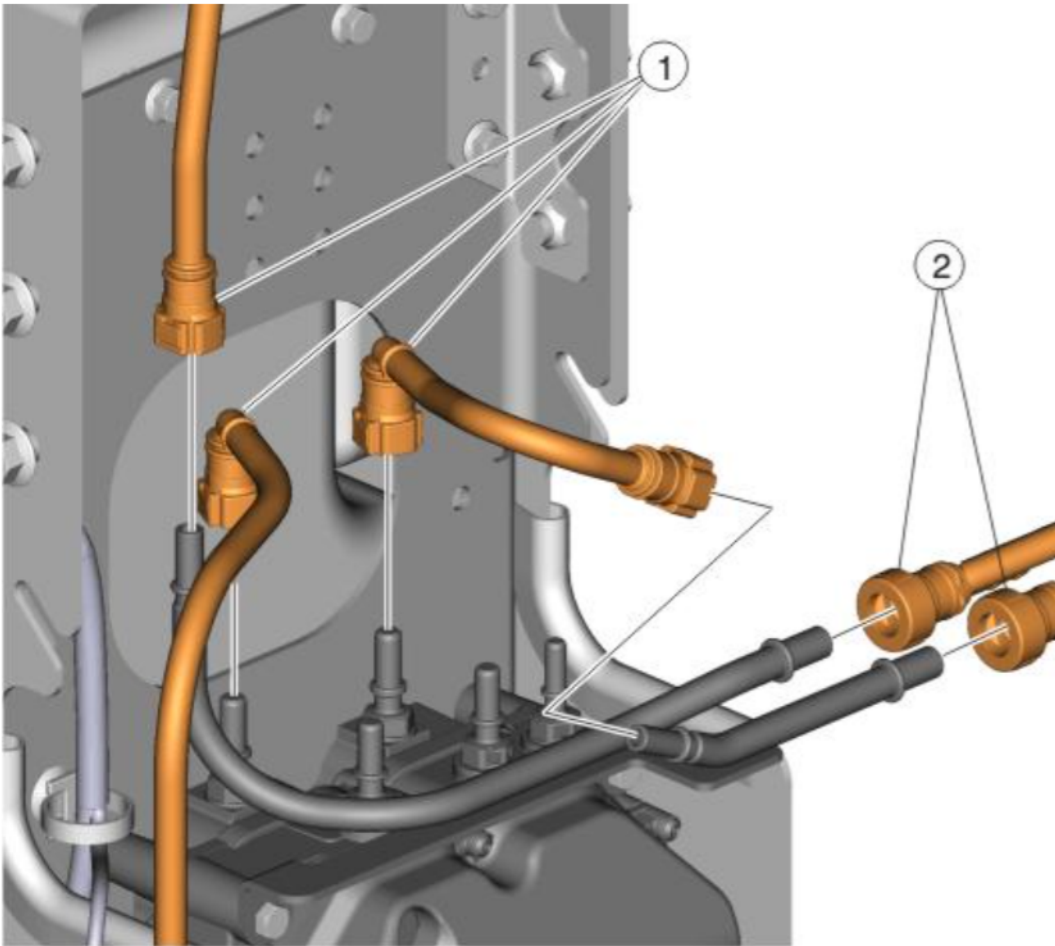

- 1. Inlet Coolant Lines
- 2. Outlet Coolant Lines

Install the inlet and outlet coolant lines onto the DEF pump.

4

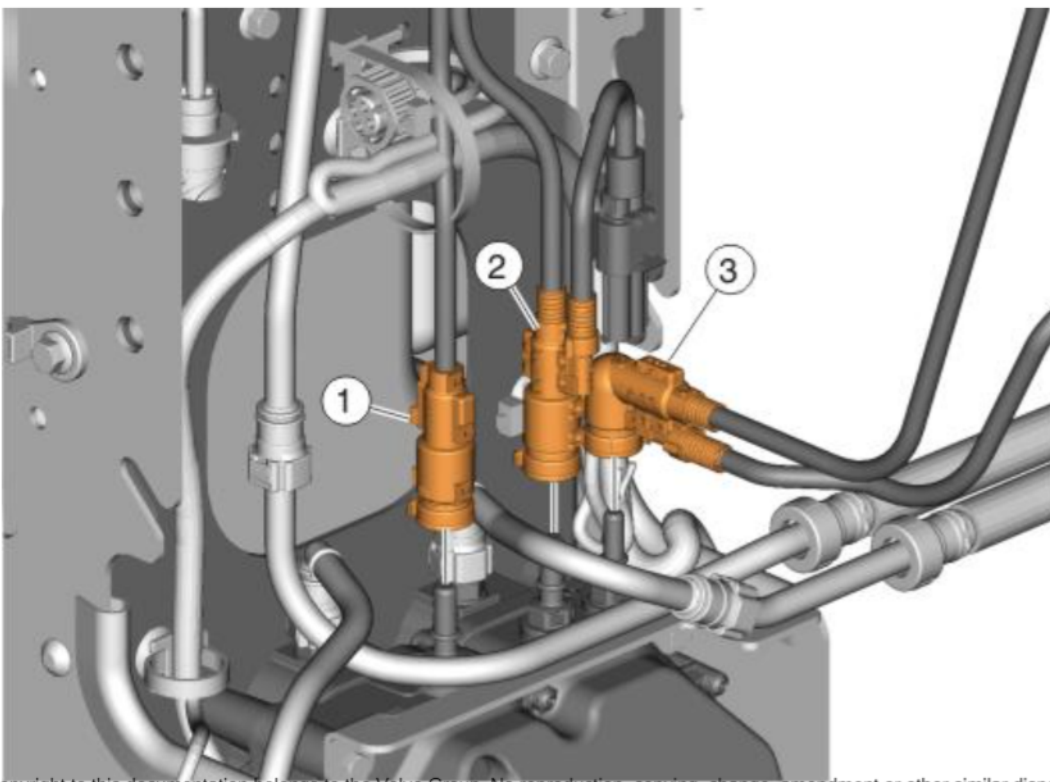

Copyright to this documentation belongs to the Volvo Group. No reproduction, copying, change, amendment or other similar disposal is entitled without prior written consent by the Volvo Group

The information contained herein is current at the time of its original distribution, but is subject to change. The reader is advised that printed copies are uncontrolled.

1. DEF Inlet Line
2. DEF Backflow Line
3. DEF Outlet Line

Install DEF inlet, backflow and outlet lines onto the pump.

Note: If inlet and backflow lines are switched, the system will not start.

5

If equipped, install the side fairing that covers the DEF tank.

6

Install all previously removed cables to the ground (negative) battery terminals.

7

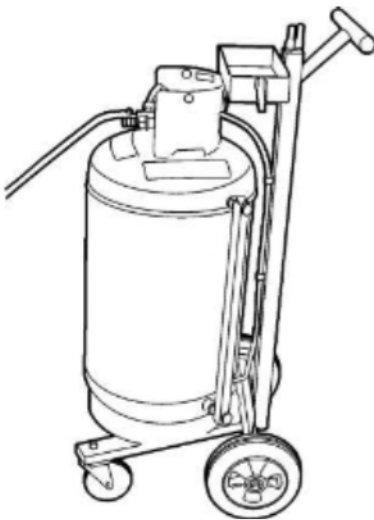

Fill the cooling system with the recommended coolant using the coolant extractor. Ensure the coolant system is full.

Special tools: [DBT2V700](#)

8

Use the diagnostic tool to purge the air out of the coolant heating system.

25832-2 Aftertreatment Diesel Exhaust Fluid (DEF) Tank, Filler Neck Insert, Replacement

You must read and understand the precautions and guidelines in Service Information, group 20, "General Safety Practices, Engine" before performing this procedure. If you are not properly trained and certified in this procedure, ask your supervisor for training before you perform it.

Removal

- 1
Apply the parking brake and place the shift lever in neutral.
- 2
Remove filler cap (1) on DEF tank.
- 3

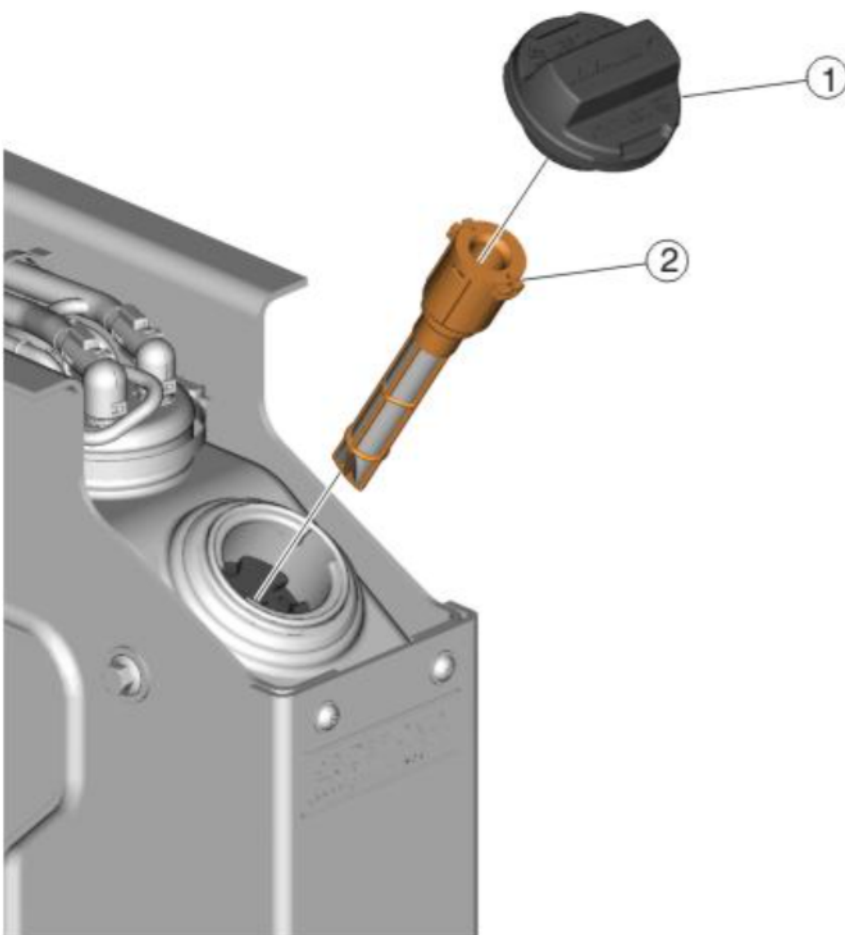

Release the retaining tabs and remove defective filler neck insert (2) from DEF tank.

Installation

- 1
Copyright to this documentation belongs to the Volvo Group. No reproduction, copying, change, amendment or other similar disposal is entitled without prior written consent by the Volvo Group

The information contained herein is current at the time of its original distribution, but is subject to change. The reader is advised that printed copies are uncontrolled.

Install replacement insert into DEF tank filler neck.

Note: Insert until the retaining tabs snap into the filler neck

2

Install filler cap.

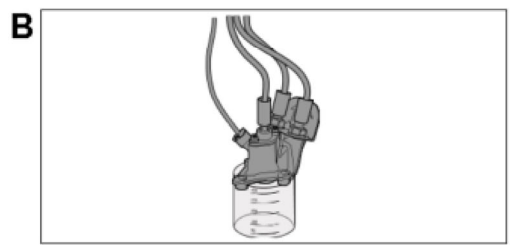
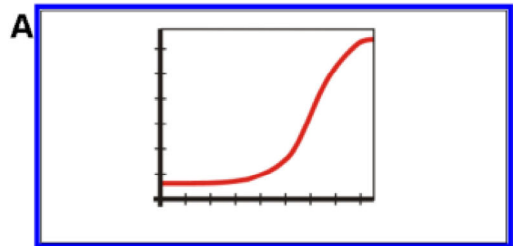

C

Exit inducement mode

D

SCR efficiency test values

2589-08-03-05 Aftertreatment selective catalytic reduction (SCR) system

Simulation

Information >> Conditions >> Execution

Purpose

Check that a newly installed, repaired, overhauled or replaced SCR system works correctly

Selections

Select the illustration corresponding to the method or test to be performed

A - System pressure build up

Check function/leakage of pump and hoses

B - Dosing test

- Check function/leakage of dosing valve
- Perform the Dosing test after the dosing valve has been replaced in order to exit inducement and clear **DTC P208E** or **P103B**

C - Exit inducement mode

- This should only be performed to exit inducement mode in order to find the root cause of **DTC P207F** or **P103C**
- Reset SCR system inducement timers

D - SCR efficiency test values

The following diagnostic trouble codes (DTCs) are concerned: **P207F** or **P20EE**











2589-08-03-05 Aftertreatment selective catalytic reduction (SCR) system

Simulation

Information >> Conditions >> Execution

Automatically checked conditions

- 1 Parking brake applied
- 2 Engine not running
- 3 DEF tank level above 10 %
- 4 Ambient temperature above 41 °F

1				
2		= 0 rpm	0 rpm	
3		> 10 %	11 %	
4		> 41 °F	41 °F	

SCR Start-up Test (Pressure build up)

▶ ◻

DEF System Status:
Waiting for start

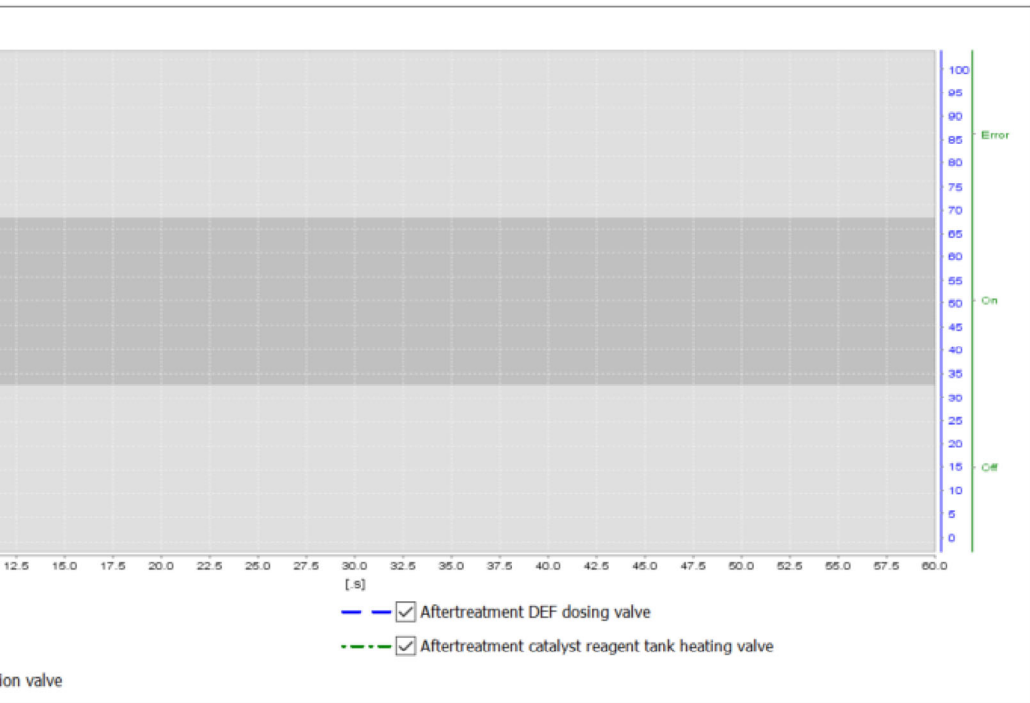

2589-08-03-05 Aftertreatment selective catalytic reduction (SCR) system

Simulation

Information >> Conditions >> Execution

Information

This test gives the possibility to start up / build up the pressure without starting the engine
The test can be used to check that the repaired, serviced or replaced dosing system is working correctly

Action

- Before starting the test, monitor the signals and make sure the DEF pressure is near 0 kPa (0 psi) without a large deviation
- Start the test

Note: The SCR Start-up test should be run for several minutes to verify that the system can hold pressure over time

Parameter values

14.5038 psi	DEF pressure
0 %	DEF pump rate in percent
0	Aftertreatment DEF dosing valve
	DEF tank heating valve
	DEF direction valve
60 %	DEF concentration

Evaluation

The pressure should build up to approximately 900 kPa (130 psi)

Test result

Select one of the following alternatives

- OK
- Not OK

Restart the operation

