

March 3, 2023

Version 2

Product Update: 2022 CR-V EPS Gearbox ReplacementSupersedes 22-011, dated June 15, 2022, to revise the information highlighted in **yellow**.**AFFECTED VEHICLES**

Year	Model	Trim	VIN Range
2022	CR-V	ALL	Check iN VIN status for eligibility
2022	CR-V Hybrid	ALL	Check iN VIN status for eligibility

REVISION SUMMARY

Under REPAIR PROCEDURE, steps 23.2 through 27.5 was added.

BACKGROUND

Due to a manufacturing issue, a short circuit in the EPS torque sensor may cause unstable power supply. This may lead to a loss of steering assistance and turn the EPS warning light ON (DTC C1423-14, Torque Sensor Power Source Circuit Malfunction).

CUSTOMER NOTIFICATION

Owners of affected vehicles will be sent a notification of this campaign.

Do an iN VIN status inquiry to make sure the vehicle is shown as eligible.

Some vehicles affected by this campaign may be in your used vehicle inventory. Repair these vehicles before they are sold.

CORRECTIVE ACTION

Remove the EPS Gearbox Assembly and replace/install a new gearbox while maintaining the original EPS Motor/Control Unit.

PARTS INFORMATION

Part Name	Part Number	Quantity
CR-V Petrol: EPS Hardware Kit	06530-TLA-305	1
CR-V Petrol: EPS Gearbox Assembly	53640-TLB-305	1
CR-V Hybrid: EPS Hardware Kit	06530-TPG-305	1
CR-V Hybrid: EPS Gearbox Assembly	53640-TPG-305	1

CUSTOMER INFORMATION:The information in this bulletin is intended for use only by skilled technicians who have the proper tools, equipment, and training to correctly and safely maintain your vehicle. These procedures should not be attempted by "do-it-yourselfers," and you should not assume this bulletin applies to your vehicle, or that your vehicle has the condition described. To determine whether this information applies, contact an authorized Honda automobile dealer.

WARRANTY CLAIM INFORMATION

Operation Number	Description	Flat Rate Time	Defect Code	Symptom Code	Template ID	Failed Part
5131M3	Petrol with 2WD: Replace the EPS gearbox. Includes steering neutral position re-learn, DTC Clear and alignment.	2.5 hr	6HE00	MCA00	A22011A	53620-TLA-A30
5131M3A	Petrol with 4WD - Add	0.4 hr	6HE00	MCA00	A22011B	53620-TLA-A30
5131M3	Hybrid: Replace the EPS gearbox. Includes steering neutral position re-learn, DTC Clear and alignment.	2.4 hr	6HE00	MCA00	A22011C	53620-TPG-A00

REPAIR PROCEDURE

Refer to the Service Information (SIS) for complete Power Steering (P/S) gearbox removal repair procedure.

1. Disconnect the 12-volt battery terminal.
2. Keep the vehicle elevated at a proper height for the procedure.
3. Remove the front wheels.
4. Disconnect the steering joint.
5. Disconnect the tie-rod end ball joint from both sides.

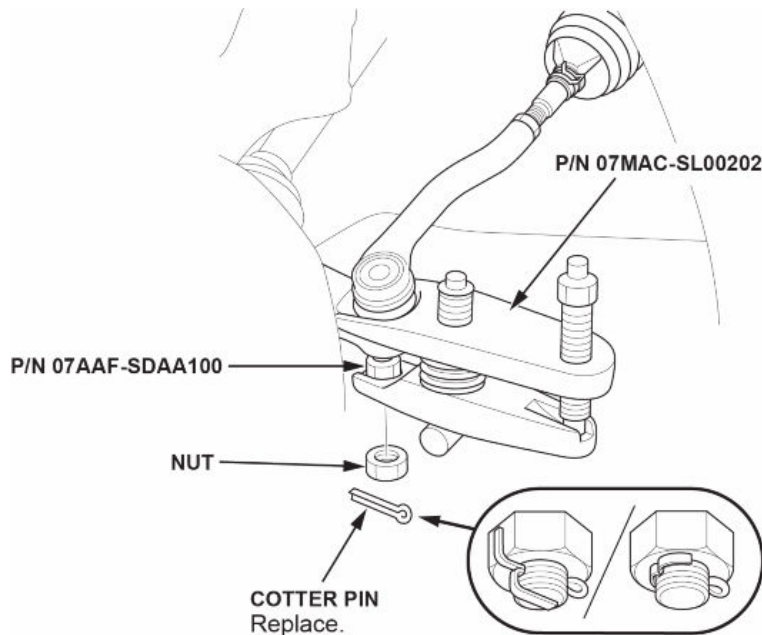

6. Remove the undercover from the engine.

7. Disconnect the EPS harness connectors.

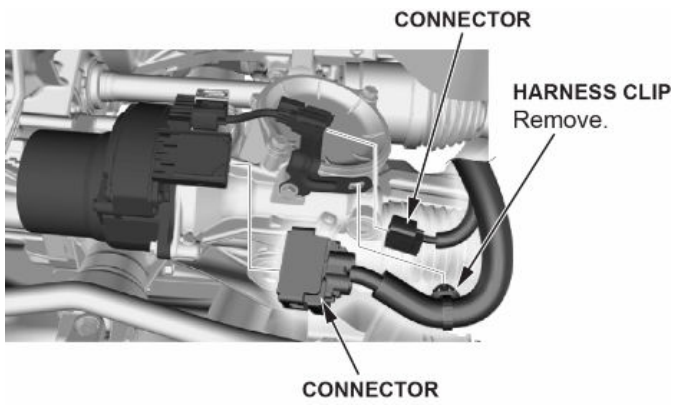

8. Disconnect the stabilizer links located on top.

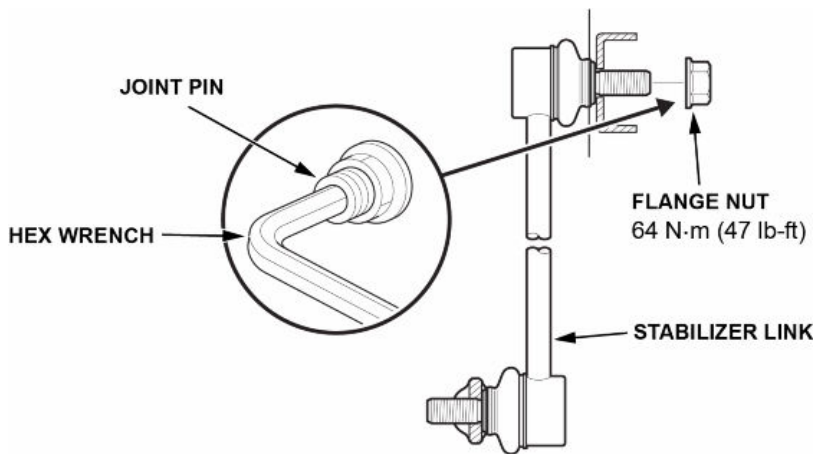

NOTE: During the subframe installation process, position the stabilizer links in vertical position for easier installation.

9. Disconnect the front lower arms.

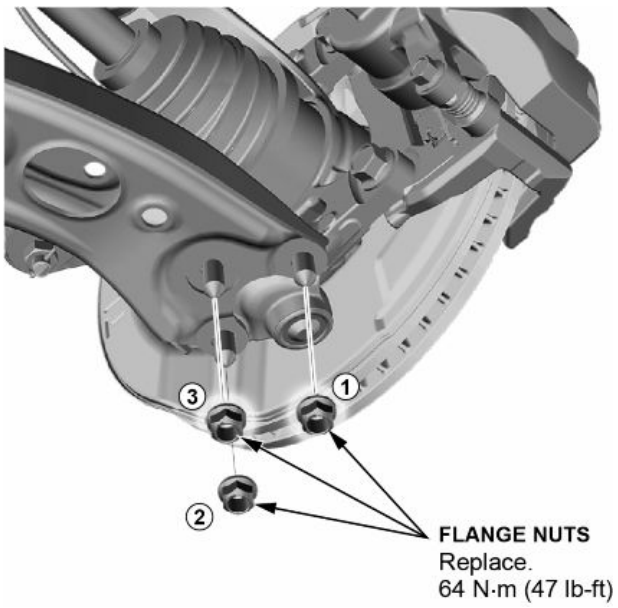

NOTE: During reassembly, loosely install the new Flange Nuts (A), then tighten them to the specified torque in the numbered sequence shown.

10. Excluding Hybrid: Remove exhaust pipe A.

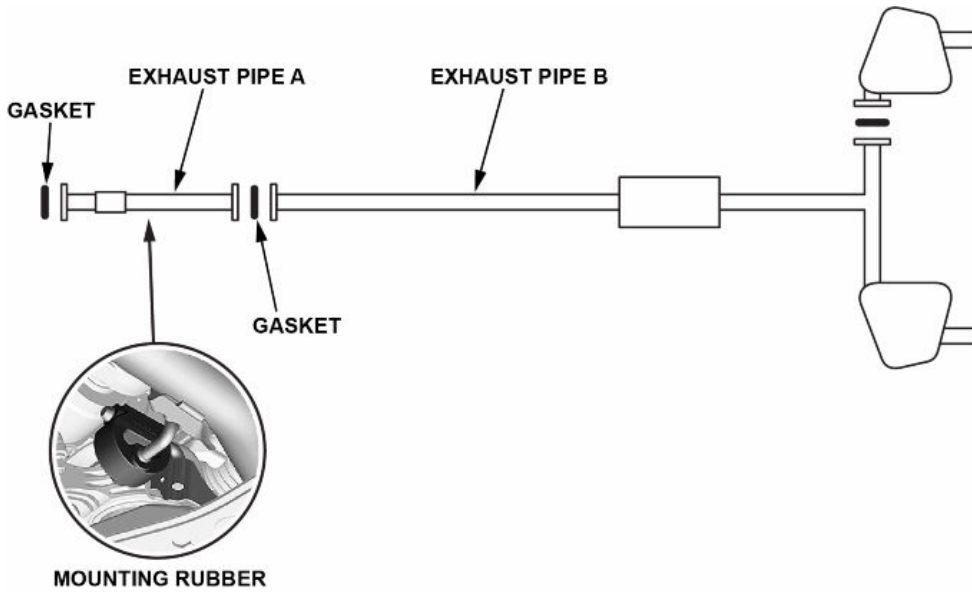

11. Petrol 4WD Only: Remove the propeller shaft.

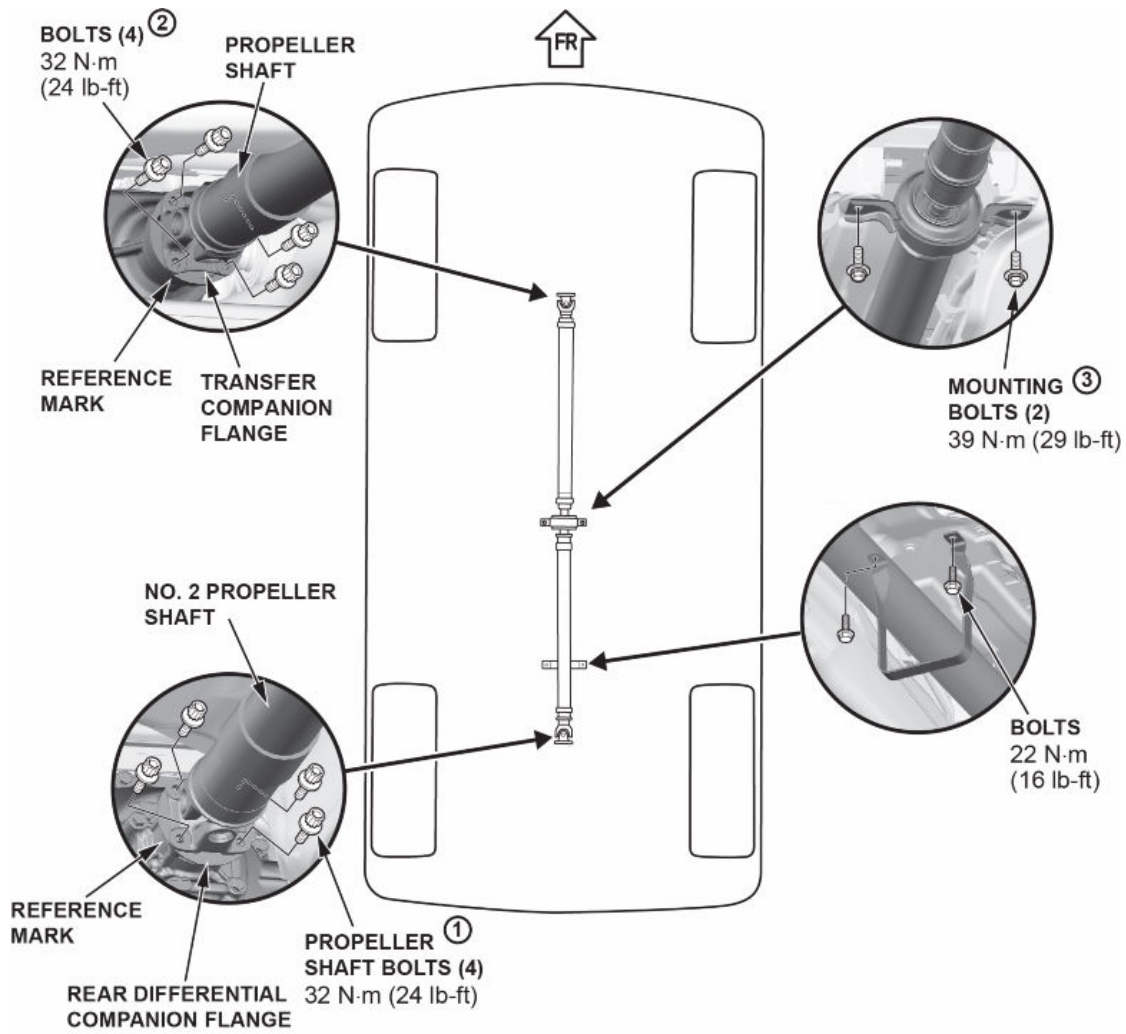

12. Remove the front subframe brace.

NOTE: After removing the front subframe mounting bolts, be sure to replace them with new ones.

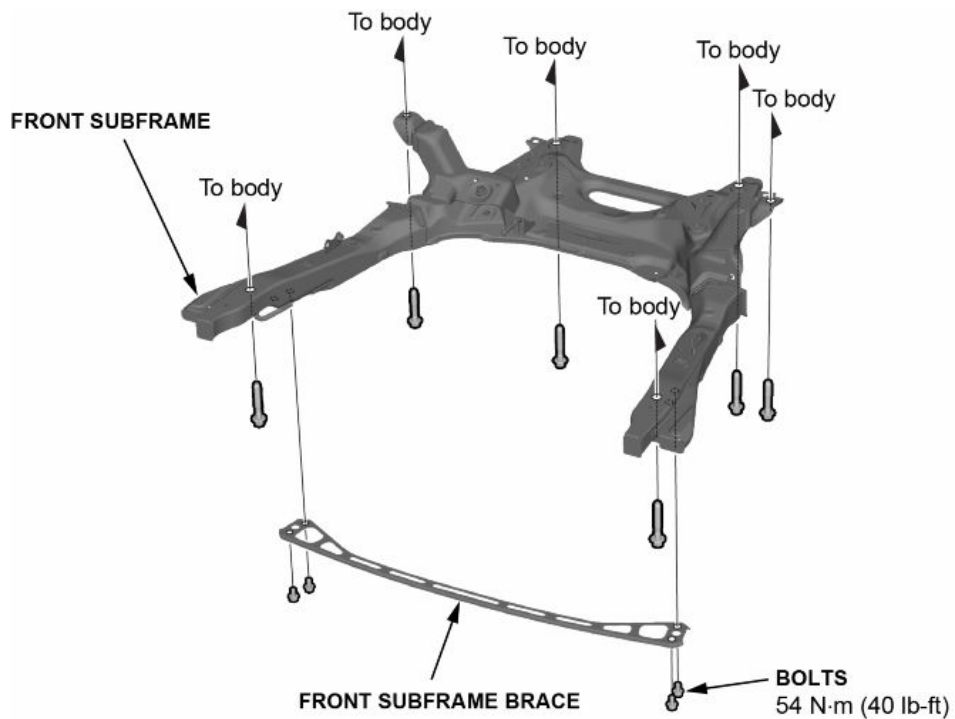

13. Remove the lower torque rod and compliance bushing.

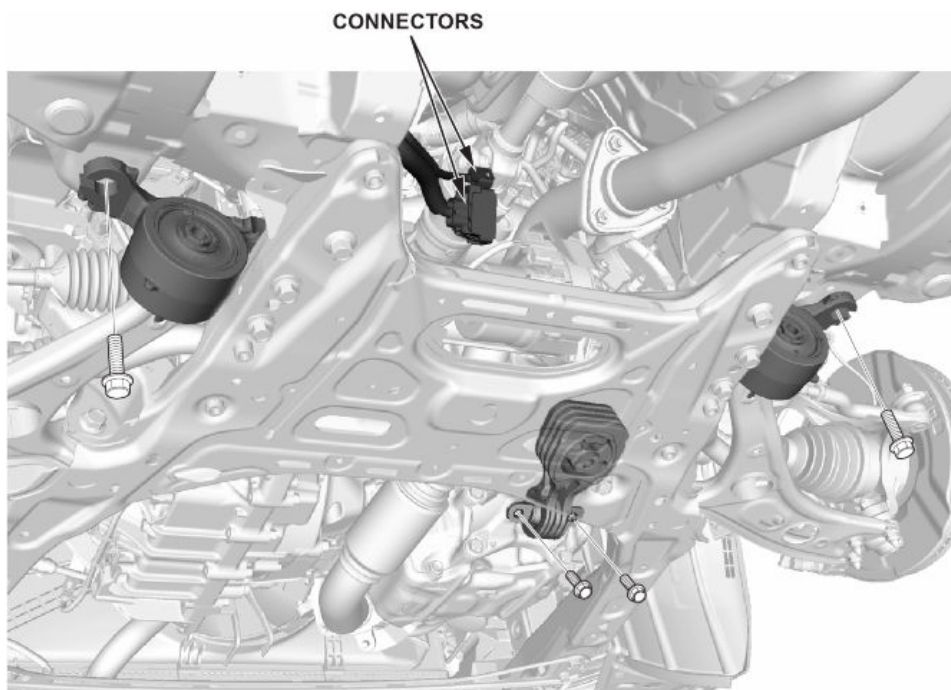

14. Remove the front lower arm mounting bolt.

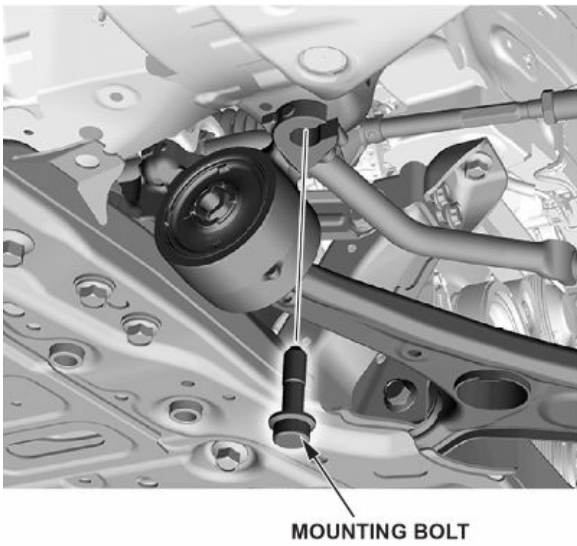

15. Drop down the front subframe.

16. Remove the front stabilizer bar bushing holder.

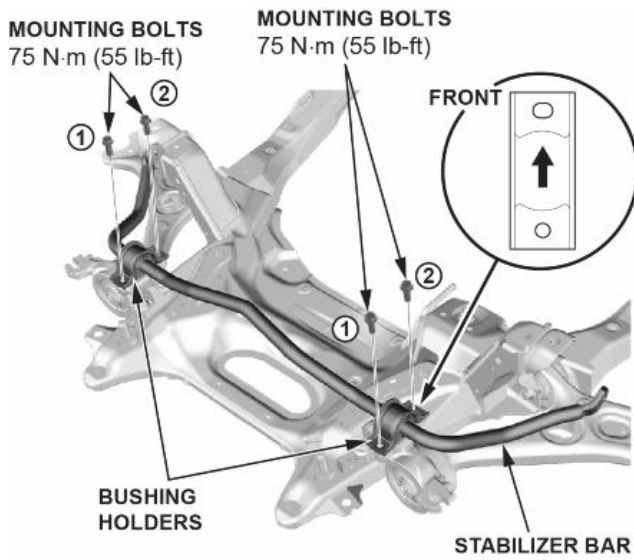

17. Remove the pinion shaft grommet.

18. Remove the steering gearbox.

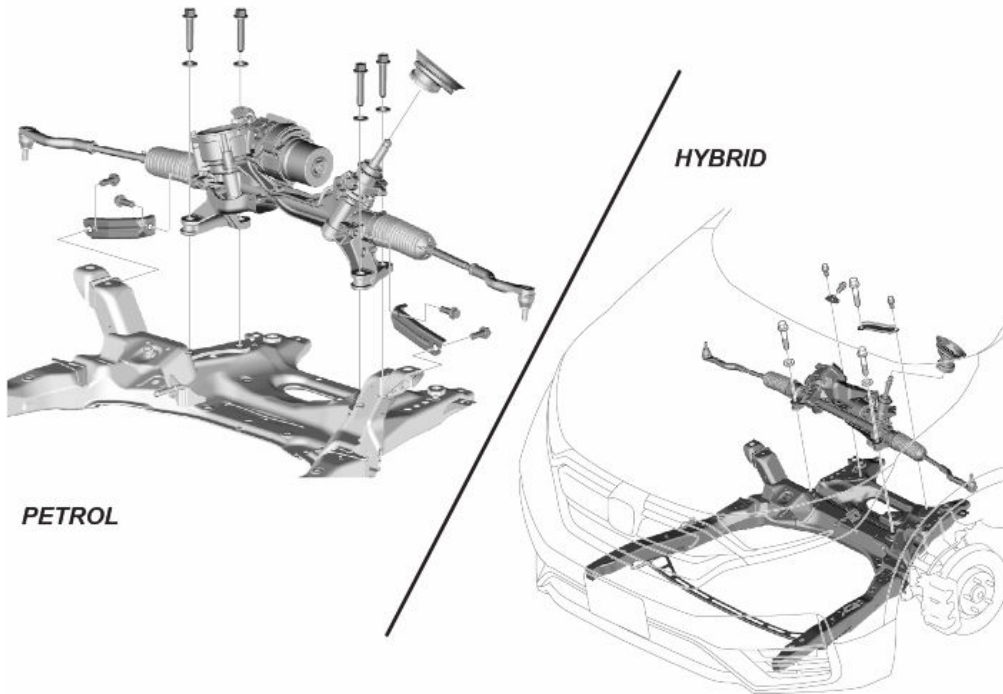

19. Mark out the steering gearbox bar code.

20. Hybrid Only: Remove the heat baffle.

21. Hybrid Only: Remove the EPS harness.

22. Remove the EPS motor.

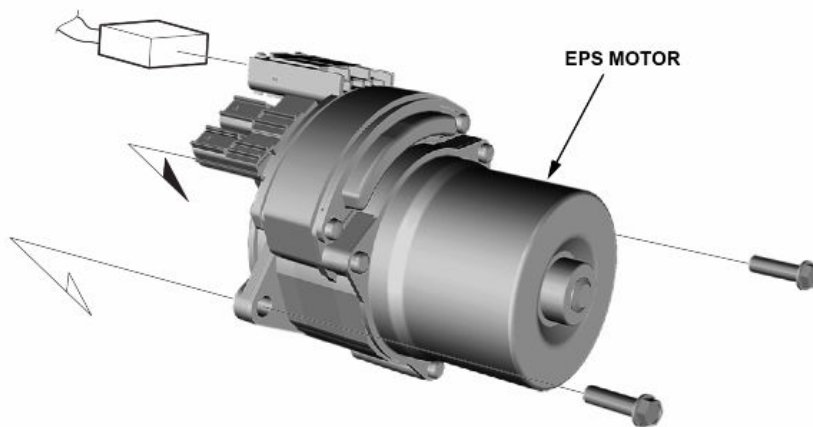

23. Install the EPS motor onto the new P/S gearbox kit, which includes the following parts:

Description	Quantity
O-Ring, Motor (79.4 x 3.1)	1
Bolt, Flange (8 x 30)	2
Bush, Motor	1
Rubber, Bush	1

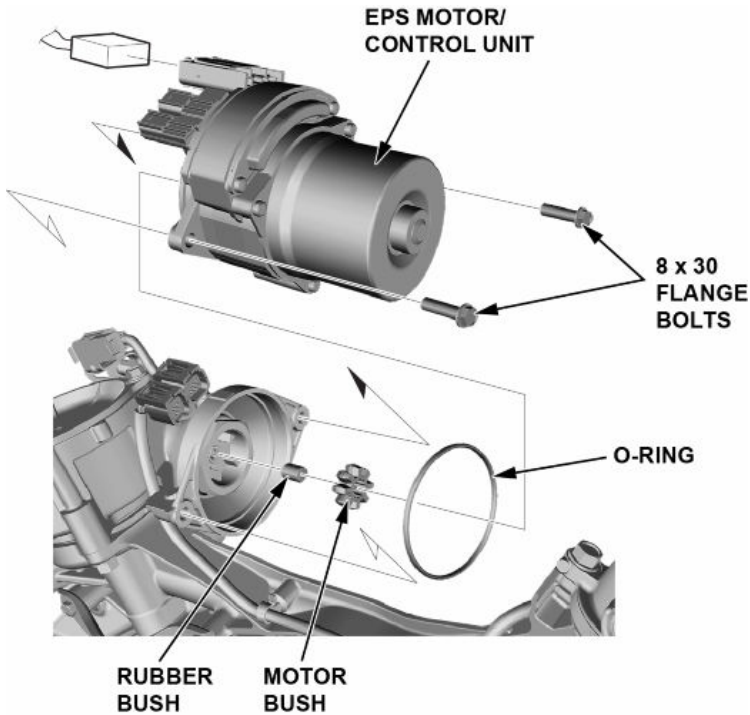

23.1. Install a new O-ring to the EPS motor/control unit.

NOTE: Apply steering grease to the O-ring if necessary.

23.2. Apply steering grease to the rubber bush and motor bush, then install them to the EPS motor/control unit.

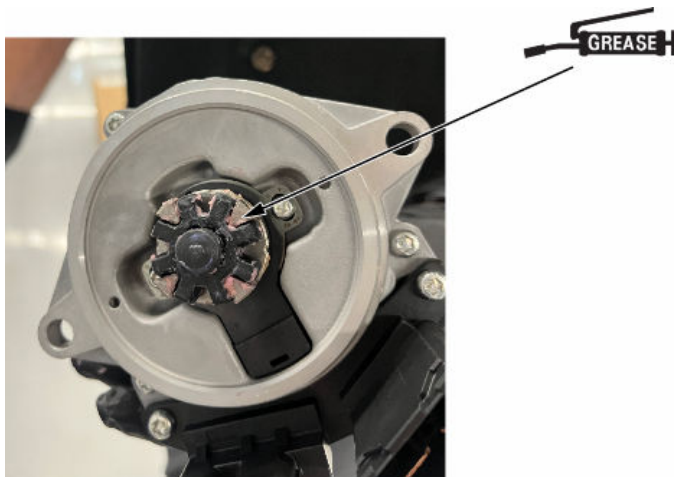

23.3. Install the EPS motor/control unit, but do not install the mounting bolts.

23.4. Turn the EPS motor/control unit two or three times to the right and left about 45 degrees.



EPS MOTOR CONTROL UNIT
Turn unit two or three times to the right and left (about 45 degrees).

23.5. Loosely install the EPS motor/control unit mounting bolts by hand but do not tighten.

NOTE:

- To prevent damaging the motor and/or gearbox, DO NOT use power tools to install or tighten the bolts.
- Make sure the EPS motor/control unit is evenly seated on the P/S Gearbox.

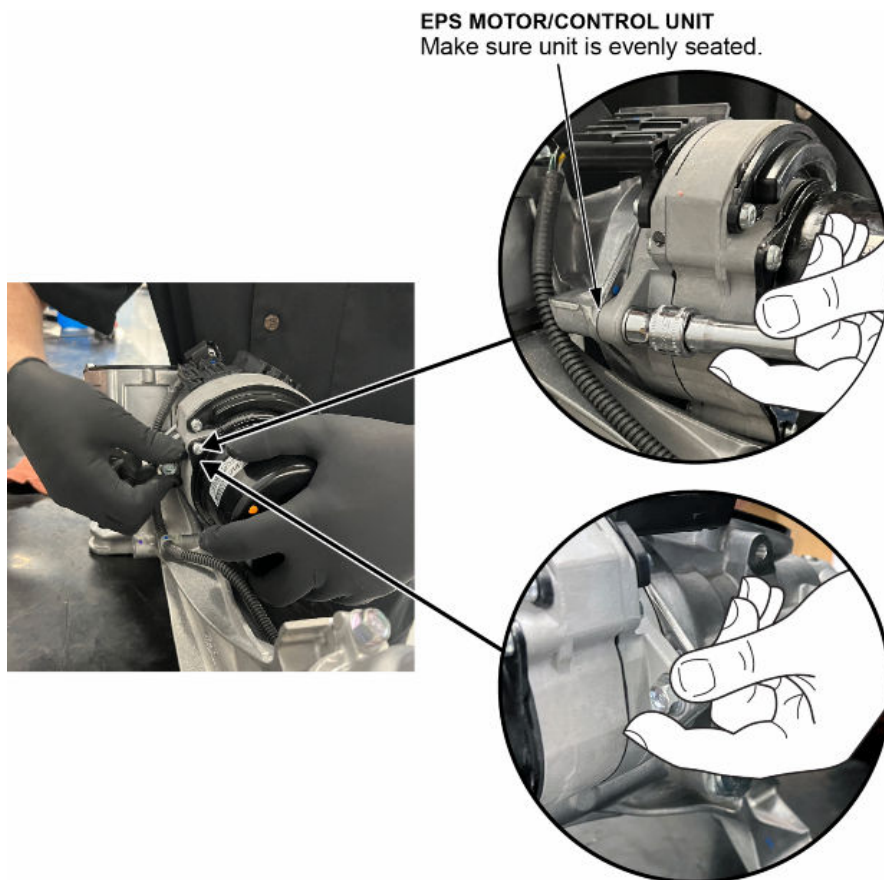

23.6. Tighten the EPS motor/control unit mounting bolts to **20 N.m (15 lb-ft)**.

24. Install the new P/S gearbox kit (with EPS motor), and reassemble in the reverse order of removal.

25. Check the steering gearbox.

25.1. With the front wheels straight ahead, make sure the steering wheel is centered and the turning revolutions from center to full lock (left and right) is equal. If not, check the installation of the steering wheel and the engagement of the joint/pinion shaft splines.

25.2. With the tires raised off the ground, check for noise and abnormality by turning the steering wheel fully to the right and left several times.

25.3. Confirm the EPS provides power assist.

25.4. Check that the EPS indicator does not come on.

26. Do a wheel alignment.

27. Do the VSA Sensor Neutral Position Memorization.

27.1. Park the vehicle on a flat and level surface.

27.2. Connect HDS to the DLC located under the driver's side of the dashboard.

27.3. Turn the vehicle to the ON mode, but do not start the engine.

27.4. Set the steering wheel in the straight ahead position.

27.5. Select the ADJUSTMENT from the ABS/TCS/VSA menu with the HDS, then select ALL SENSOR, and follow the screen prompts.

END