



Service Bulletin

Bulletin No.: 18-NA-361



Date: March, 2023

TECHNICAL

Subject: Diagnostic Tip for Diesel Fuel System Contamination, No Start, Malfunction Indicator Lamp (MIL) Illuminated - DTC P0087, P026D, P0461, P0463, P0171, P0172, P0300 , P1029, P129F, P2A00, P2264, P228C, P228A, P228B, and/or P228D Set

Brand:	Model:	Model Year:		VIN:		Engine:	Transmission:
		from	to	from	to		
Cadillac	Escalade Models	2021	2023			3.0L Turbo Diesel (LM2)	
Chevrolet	Cruze	2014	2015			2.0L Diesel (LUZ)	
	Cruze	2018	2019			1.6L Diesel (LH7)	
	Equinox	2018	2019			6.6L Turbo Diesel (L5P)	
	Silverado	2017	2018			3.0L Turbo Diesel (LM2)	
	Silverado 1500 - 4WD (New Model, 12th VIN Digit = 7)	2019	2019			3.0L Turbo Diesel (LM2)	—
	Silverado 1500	2020	2021				
	Silverado 1500 LTD (RPO J21, VIN Digit 5 = W / Y)	2022	2022				
	Silverado 1500 New (RPO J22, VIN Digit 5 = A / D)						
	Silverado 1500	2023	2023			3.0L Diesel (LZ0)	
	Silverado 2500/3500	2019	2023			6.6L V-8 Duramax Turbo Diesel (L5P)	
	Silverado 4500HD, 5500HD and 6500HD	2019	2023			6.6L V-8 Duramax Turbo Diesel (L5D)	
	Silverado LD	2019	2019			6.6L V-8 Duramax Turbo Diesel (L5P)	
	Suburban	2021	2023			3.0L Turbo Diesel (LM2)	
	Tahoe	2020	2023			3.0L Turbo Diesel (LM2)	

Brand:	Model:	Model Year:		VIN:		Engine:	Transmission:
		from	to	from	to		
GMC	Sierra	2017	2018	—	—	6.6L V-8 Duramax Turbo Diesel (L5P)	—
	Sierra 1500	2020	2021				
	Sierra 1500 Limited (RPO J21, VIN Digit 5 = 8 / 9)	2022	2022				
	Sierra 1500 New (RPO J22, VIN Digit 5 = H / U)						
	Sierra 1500	2023	2023				
	Sierra 2500/3500	2019	2023				
	Terrain	2018	2019				
	Yukon	2021	2023				
						3.0L Turbo Diesel (LM2)	
						3.0L Diesel (LZ0)	
						6.6L V-8 Duramax Turbo Diesel (L5P)	
						1.6L Diesel (LH7)	

<p>Involved Region or Country</p>	<p>North America, Middle East, Israel, Palestine, Chile (West), Paraguay (West), Thailand (ASEAN), Australia/New Zealand</p>
<p>Condition</p>	<p>Some customers may comment on one or more of the following conditions:</p> <ul style="list-style-type: none"> • MIL is illuminated • No start <div style="display: flex; justify-content: space-around; align-items: center;">   </div> <p style="text-align: right; font-size: small;">5168457</p> <p>Note: If removing the fuel filter from the filter housing, clean the outside of the fuel filter assembly prior to removing the fuel/water filter from the housing.</p> <p>Some technicians may find metal particles in the fuel system during diagnostics.</p> <p>Important: If the fuel/water filter has been removed for inspection, Do Not install the filter back into the housing until the fuel/water separator reservoir has been cleaned. Refer to the Information on Fuel/Water Filter Removal section below.</p> <p>Some technicians may also find one or more of the following DTCs set in the Engine Control Module (ECM):</p> <ul style="list-style-type: none"> • P0087: : Fuel Rail Low Pressure • P0171: Fuel System Lean • P0172: Fuel System Rich • P026D: Injection Quantity Too High • P0300: Engine Misfire Detected • P0461: Fuel Level Sensor Performance • P0463: Fuel Level Sensor Circuit High Voltage • P1029: Fuel Pump Motor Phase U-V-W Circuits • P129F: Fuel Pump Power Control Module Fuel Pump Speed Signal Incorrect • P2264: Water in Fuel Sensor Circuit • P228A: : Fuel Pressure Regulator 1 Control - Forced Engine Shutdown • P228B: : Fuel Pressure Regulator 2 Control - Forced Engine Shutdown • P228C: : Fuel Pressure Regulator 1 Control Performance - Low Pressure • P228D: : Fuel Pressure Regulator 1 Control Performance - High Pressure • P2A00: HO2S Performance Sensor 1

Correction	<p>If you encounter such a situation, DO NOT replace the fuel system as described in Service Bulletin #16-NA-102.</p> <p>Please perform the following fuel system flushing procedure prior to performing further diagnostics.</p> <p>Once the fuel system has been flushed, continue with diagnostics as described in SI.</p>
-------------------	--

Important: Service agents must comply with all International, Federal, State, Provincial, and/or Local laws applicable to the activities it performs under this bulletin, including but not limited to handling, deploying, preparing, classifying, packaging, marking, labeling, and shipping dangerous goods. In the event of a conflict between the procedures set forth in this bulletin and the laws that apply to your dealership, you must follow those applicable laws.

Vehicles that have been Mis-filled

Note: Mis-fuelling or the presents of contamination in the fuel is not a product issue and should not be charged to warranty,

By analyzing warranty return parts, GM engineering has found that many fuel pumps and fuel injection system component failures showed evidence of DEF contamination in the fuel. Just recently, SI Contaminants-in-Fuel Diagnosis has been updated with an accurate test for determining if DEF can be found in the fuel system. This adds to our toolbox used for evaluating diesel fuel.

Here are some of the tools to help determine if a vehicle has contaminated fuel:

1. Test for the presents of DEF in the fuel. Refer to Contaminants-in-Fuel Diagnosis in SI.
2. Test the Specific Gravity (API) of the fuel. Refer to Fuel Specific Gravity Testing in SI.
3. Place a fuel sample in a clear container. Look at the color of the fuel compared to what you normally see in your region. Cloudy looking fuel is an indication that there may be an issue with the fuel.
4. Look for any separation of the fuel. This can be anything from sediment settling or different layers like water or DEF being seen.
5. Put a sample of the fuel into a Styrofoam cup, and place the cup in a drain pan, fuel contaminated with gasoline will certainly melt the cup within half an hour. B20 Biodiesel will also melt a Styrofoam cup but will take about an hour.

R-99 or R-95 Diesel Fuel

Renewable diesel (RD) is essentially any diesel fuel produced from a renewable feedstock that is predominantly hydrocarbon (not oxygenates). RD meets the requirements for use in a diesel engine.

B20 (Biodiesel) fuel is a blend of up to 20-percent bio components and 80-percent conventional diesel. This helps lower carbon dioxide emissions and lessens dependence on petroleum.

All Fuel must meet ASTM D975 diesel fuel standards. Renewable or BioMass fuels have an API of up to 50. The API can be between 40 and 50, depending on if the fuel is a combination of #1, #2, and the RD fuel. Most all of this fuel is clear in color when not mixed with other fuels.

Information on Fuel/Water Filter Removal

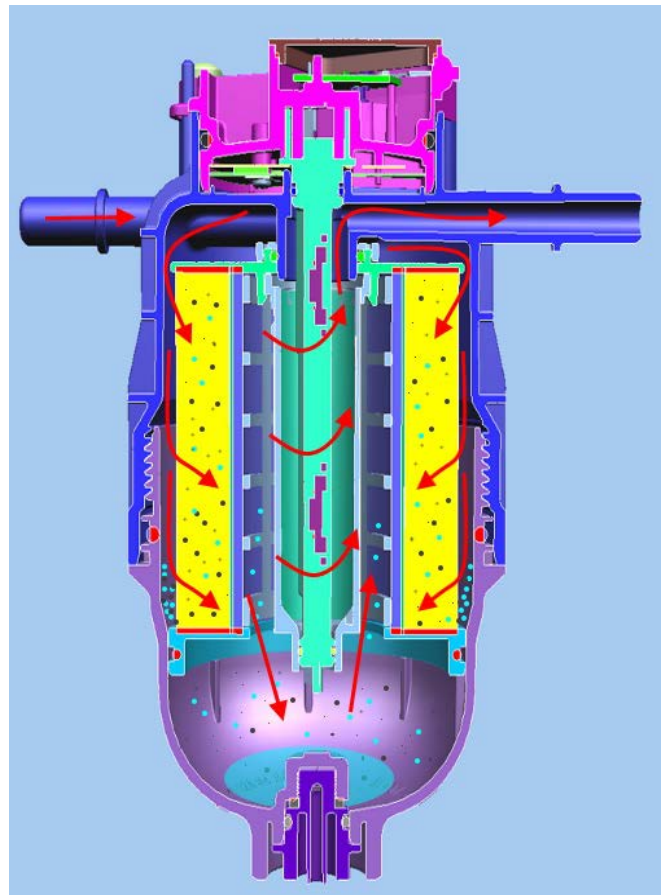

5417311

Water or other like contaminates in the fuel will create driveability concerns and loss of engine power. If water and/or debris is present in the fuel system, the fuel cannot cool and lubricate the components properly, causing overheating, rust and corrosion. This can result in component failure. Water and debris can enter the fuel system in several ways, either through a contaminated refueling source, plugged venting or through long term condensation in the vehicle fuel tanks.

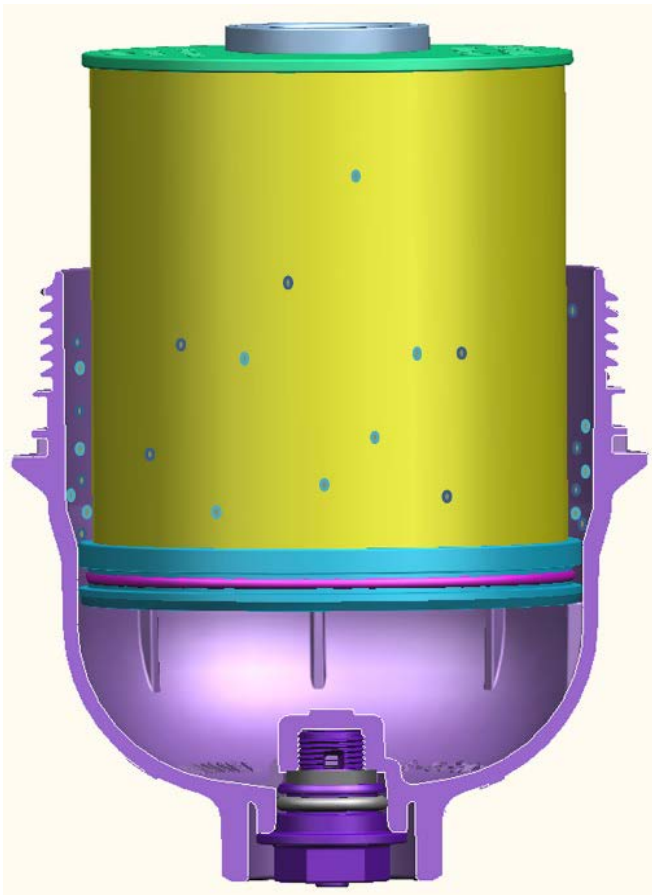

5417281

1. Remove the fuel/water filter from the housing using care not to separate the filter from the fuel/water separator reservoir.

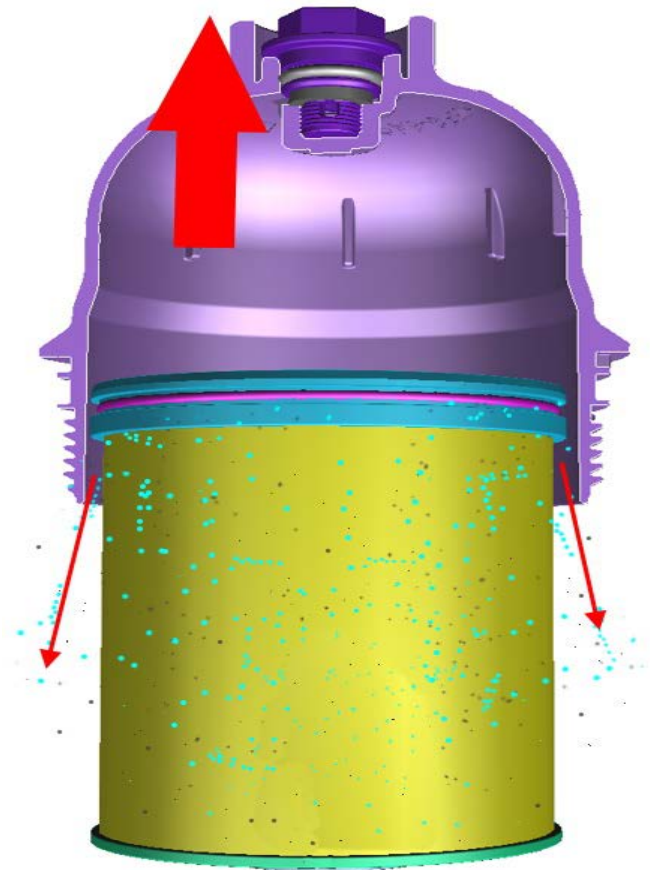

5417298

2. Using care, separate the filter from the fuel/water separator reservoir by placing the filter downwards in a clean/dry drain pan.

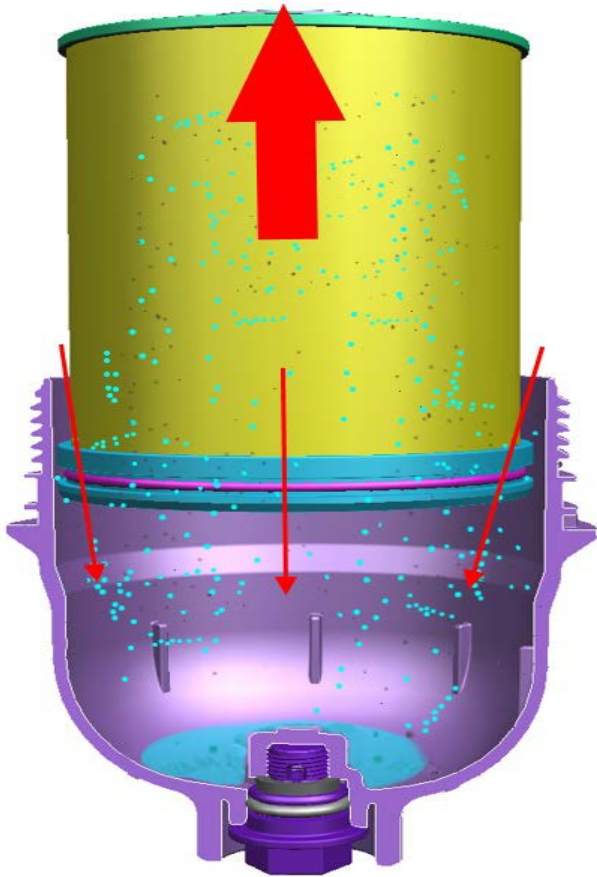

5417283

- If the filter is facing upwards, debris left on the sides of the filter may escape past the O-ring seal during removal and settle in the fuel/water separator reservoir.
 - Water and/or debris left in the fuel/water separator reservoir will flow past the filter, directly into the fuel system when re-started.
 - Debris that is allowed past the filter and into the fuel system can cause fuel injection issues that may set DTCs P2A00, P026D, P0300, P0172. Replacement of fuel injectors without a complete cleaning of the fuel system will only be a temporary fix until the debris gets into the new injectors.
3. Inspect the fuel/water separator reservoir and filter for heavy debris.
- If heavy debris is found in the filter, clean the fuel/water separator reservoir and continue to the Fuel System Flushing Procedure below.
 - If no signs of debris are found, clean the fuel/water separator reservoir, install a new filter and refer to SI for further diagnostics.

Fuel System Flushing Procedure

Note: Performing the test may aid in determining the source and section of the fuel system causing the contamination.

1. If removed, re-install the fuel filter.

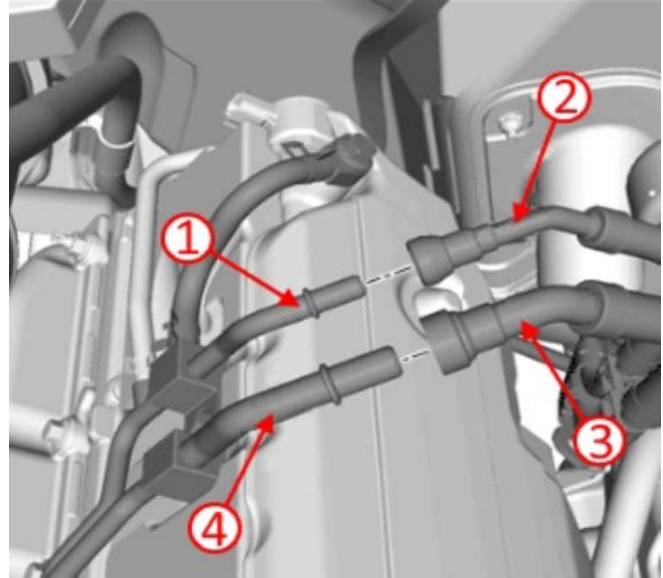

5167517

2. Disconnect the chassis side fuel feed hose (3) from the engine side fuel feed pipe (4).
3. Place the end of the chassis side fuel feed hose into a clean container and run the fuel pump to clean any debris left in the fuel lines, approximately 2-3 gallons (7.6-11.4L).
4. Clean the fuel/water separator reservoir.
5. Install a new fuel filter.
6. Disconnect the chassis side fuel return hose (2) from the engine side return pipe (1).

Note: The white "Tubing" shown in the graphics below depict the route of the clear line, not the length.

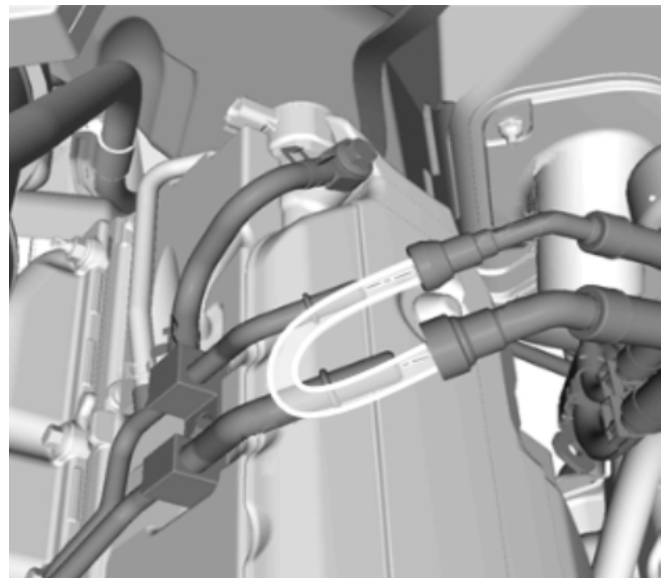

5168476

- 7. Install a clear line between the fuel supply hose and the fuel return hose.
- 8. Run the fuel pump until the fuel runs clear in the line.

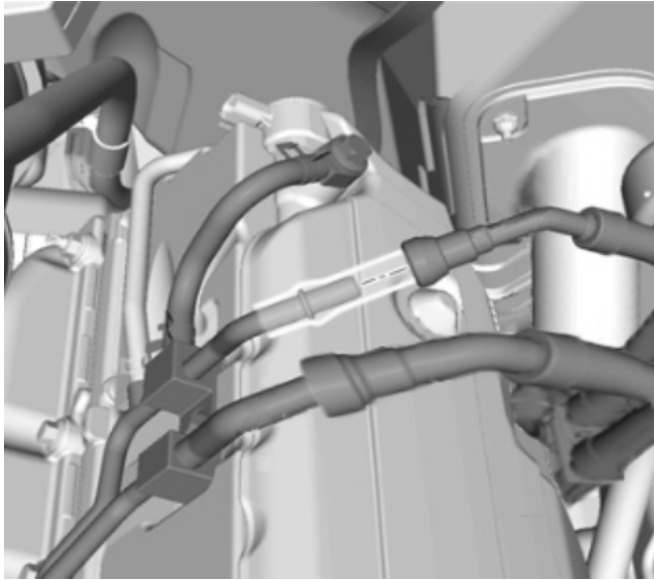

5168447

- 9. Connect the fuel supply hose to the engine supply pipe.
- 10. Install a clear line in series at the fuel return hose to the engine return pipe.
- 11. Run the fuel pump until the fuel runs clear in the line.

Reconnect all fuel lines and retest for any codes or symptoms in the vehicle.

Parts Information

No parts are required for this repair.

Version	13
Modified	<p>Released December 10, 2018</p> <p>Revised June 24, 2019 – Added 2020 to Model Year.</p> <p>Revised August 14, 2019 – Added 2019 and 2020 Silverado HD Models.</p> <p>Revised October 03, 2019 – Added Information on Fuel/Water Filter Removal section.</p> <p>Revised October 14, 2019 – Removed LCF and added 2020 Silverado/Sierra 1500 with LM2.</p> <p>Revised September 09, 2020 – Added DTCs to the Subject, Condition and Information on Fuel/Water Filter Removal sections.</p> <p>Revised October 20, 2020 – Added the 2021 Model Year to Silverado and Sierra Models and additional engine descriptions.</p> <p>Revised May 06, 2021 - Add Note to Condition section to clean the Filter Housing Assembly.</p> <p>Revised January 10, 2022 - Added 2022 to Model Year.</p> <p>Revised September 06, 2022 - Added 2023 to Model Year.</p> <p>Revised November 07, 2022 - Update P-codes in Condition section, and Added Vehicles that have been Mis-filled and R-99 or R-95 Diesel Fuel sections.</p> <p>Revised November 29, 2022 - Added P2264 to Subject and Condition section.</p> <p>Revised March 10, 2023 - Removed the use of renewable Diesel (R-99, RD100, R-95) Information from the R-99 or R-95 Diesel Fuel section.</p>

