



Service Bulletin

Bulletin No.: 22-NA-168

Date: March, 2023

INFORMATION

Subject: Diagnostic Tip for Checking Exhaust System for Leaks, Malfunction Indicator Lamp (MIL) Illuminated - DTC P11D5, P14D9, P20EE, P2C7A and/or P0421 Set

Brand:	Model:	Model Year:		VIN:		Engine:	Transmission:
		from	to	from	to		
Cadillac	Escalade Models	2021	2023	—	—	Duramax 3.0L Turbo Diesel (RPO LM2)	—
Chevrolet	Silverado 1500	2020	2021				
	Silverado 1500 - LTD (RPO J21, VIN Digit 5 = W/Y)	2022	2022				
	Silverado 1500 - New (RPO J22, VIN Digit 5 = A/D)						
	Suburban						
	Tahoe	2021	2023				
GMC	Sierra 1500	2020	2021				
	Sierra 1500 - Limited (RPO J21, VIN Digit 5 = 8/9)	2022	2022				
	Sierra 1500 - New (RPO J22, VIN Digit 5 = H/U)						
	Yukon Models	2021	2023				

Involved Region or Country	North America, Russia, Middle East, Chile, Colombia, Ecuador, Paraguay, Peru, Japan, Cadillac Korea (South Korea), Thailand, Australia/New Zealand
Condition	<p>Some customers may comment that the MIL is illuminated.</p> <p>Technicians may comment on one or more of the following DTCs set in the Engine Control Module (ECM):</p> <ul style="list-style-type: none"> • P11D5: Nitrogen Oxides Sensor 2 Exceeded Minimum Learning Limit • P14D9: NOx Sensor Exceeded Minimum Learning Limit Bank 1 Sensor 3 • P20EE: Nitrogen Oxides Catalytic Converter Efficiency Below Threshold • P2C7A: Nitrogen Oxides Catalytic Converter 2 Efficiency Below Threshold • P0421: Catalytic Converter Low Efficiency
Cause	This condition may be caused by an exhaust leak that will let oxygen into the exhaust and will make the Nitrogen Oxide sensors read incorrectly.

Correction	<p>There are two different types of leak tests that can be performed on the induction or exhaust system. The first is a smoke leak test where the area being tested is filled with pressurized smoke and the leak is detected by visually inspecting for smoke exiting the system. The second is a pressure leak test where soapy water is applied to the outside of the area being tested and leaks are visually identified by the presence of bubbles forming over the leaking area.</p> <p>Advantages to using a Smoke leak test vs. a Pressure leak test:</p> <ul style="list-style-type: none">• Smoke is easy to see exiting relatively large leak locations. The smoke bellows out.• You can sometimes smell the smoke to help identify a leak location. <p>Disadvantages to using a Smoke leak test vs. a Pressure leak test:</p> <ul style="list-style-type: none">• Smoke is hard to see exiting a small leak as the smoke is traveling fast.• Smoke can be removed when it passes through a DPF. <p>Advantages to using a Pressure leak test vs. a Smoke leak test:</p> <ul style="list-style-type: none">• Bubbles will easily form over a small leak making it easy to spot.• You can leave soapy water on the surface being tested while you go to eat lunch. When you return, you should still see bubbles. <p>Disadvantages to using a Pressure leak test vs. a Smoke leak test:</p> <ul style="list-style-type: none">• It is very difficult for a soap film to form over a large leak to make a bubble.
-------------------	--

Important: Service agents must comply with all International, Federal, State, Provincial, and/or Local laws applicable to the activities it performs under this bulletin, including but not limited to handling, deploying, preparing, classifying, packaging, marking, labeling, and shipping dangerous goods. In the event of a conflict between the procedures set forth in this bulletin and the laws that apply to your dealership, you must follow those applicable laws.

Service Procedure

Note: A leak at the turbocharger vane actuator shaft is considered a normal condition. Any smoke or bubbles from this area should be ignored.

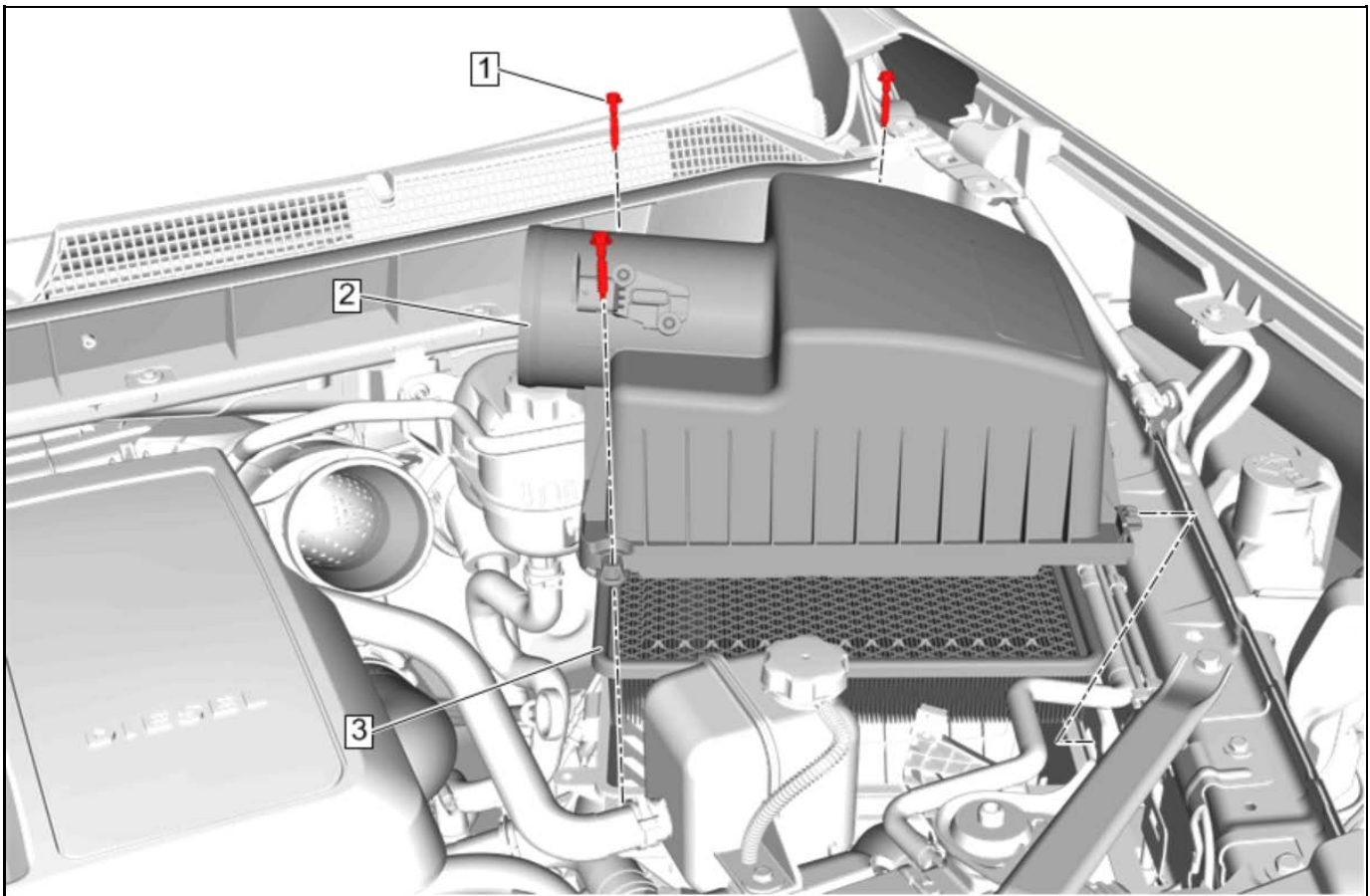

5150254

1. Remove the air filter (3) from the air filter housing. Refer to *Air Cleaner Element Replacement* in SI.

3. Re-install the air filter into the air filter housing.
4. Raise the vehicle.



6140930

2. Put the air filter in a plastic bag.

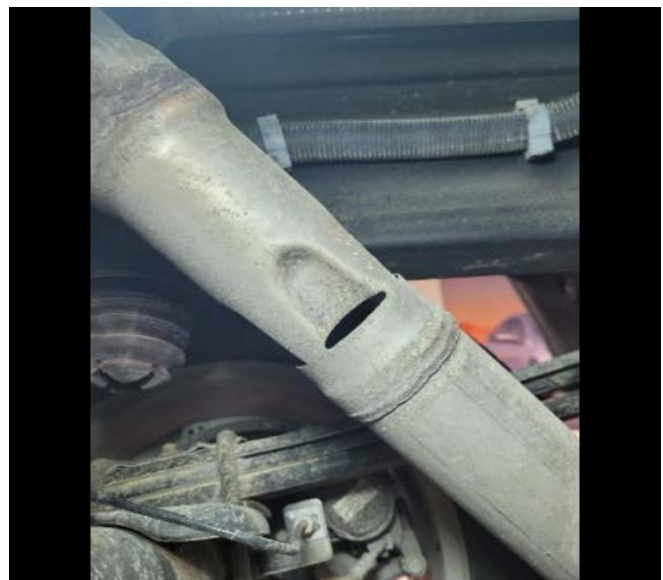

6140932

5. Locate the cooling ports in the exhaust system.



6140943

Note: The graphic depicts a single exhaust system. If equipped with a dual exhaust, both cooling holes will need to be taped off and one of the tail pipes sealed with a rag or equivalent.

6. Tape the holes utilizing duct tape or equivalent.

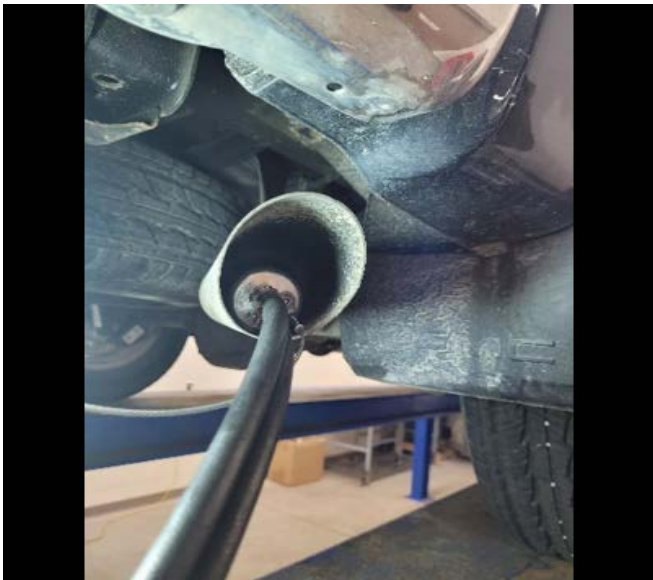

6140928

7. Install the inlatable adapter (second largest adapter for our application) for the GE-52250 machine and insert it into the tailpipe.
8. Attach the GE-52250 to the adapter and shop air supply.
9. Command the vapor test, and adjust the test pressure to 34–55 kPa (5-8 psi).

Note: To aid in testing, it may be useful to remove the right front tire and front wheelhouse liner.

10. Using a soapy water mixture, spray all connections, welds, and sensors with the soapy water mixture, and look for air leaks (See Examples of Exhaust Leak Areas of Concern section below).
11. Once all the leaks are detected and corrected, verify that the exhaust is sealed by retesting with the GE-52250.

Important: If there is a leak between the under floor SCR and the tail pipe, this needs to either be temporarily sealed or corrected to allow the pressure to get to the front of the exhaust.

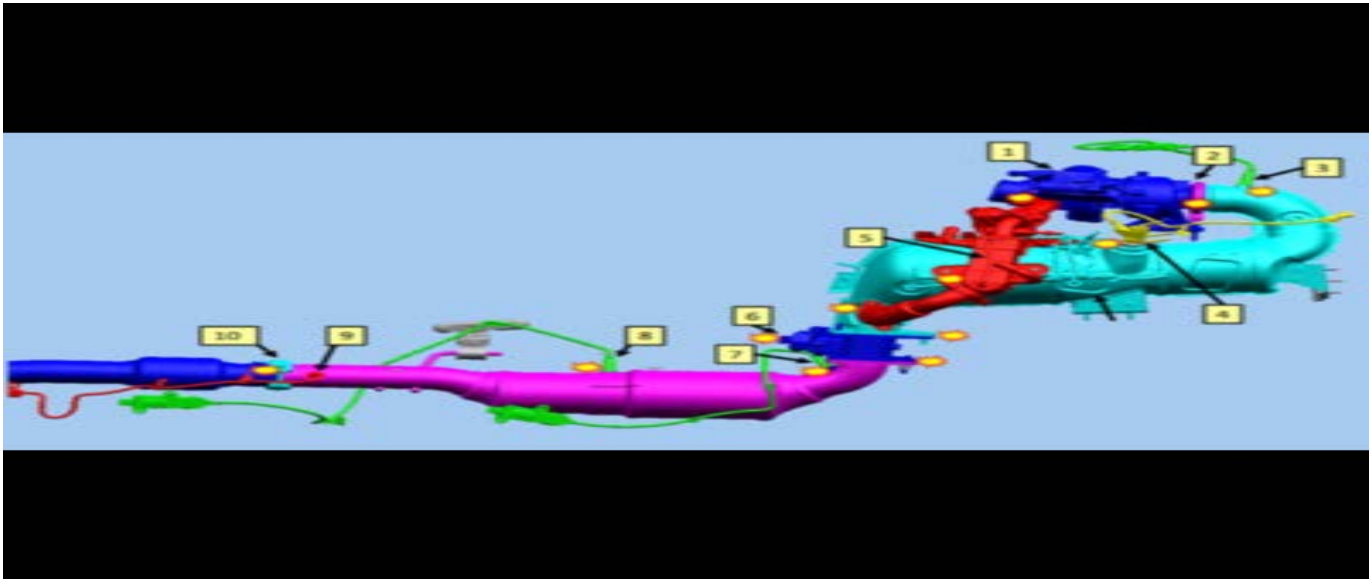

6141008

Examples of Exhaust Leak Areas of Concern

LM2 After Treatment Exhaust System	
Note: The areas that have been marked on the graphic require inspection for leaks.	
Exhaust Leak Areas of Concern	
1	Turbocharger
2	V-Band Clamp
3	NOx Sensor
4	Def Injector
5	LP EGR Cooler
6	EXH. Throttle/Back Pressure Valve
7	NOx 2 Sensor
8	NOx 3 Sensor
9	Particulate Matter Sensor
10	Norma Band Clamp

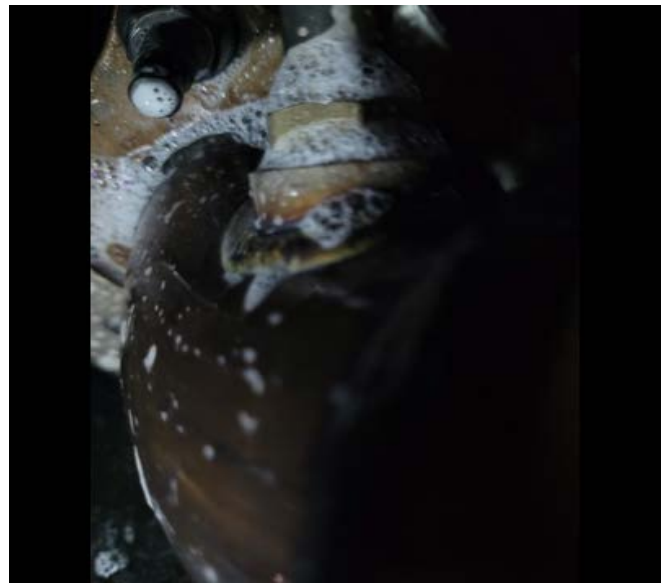

6140935

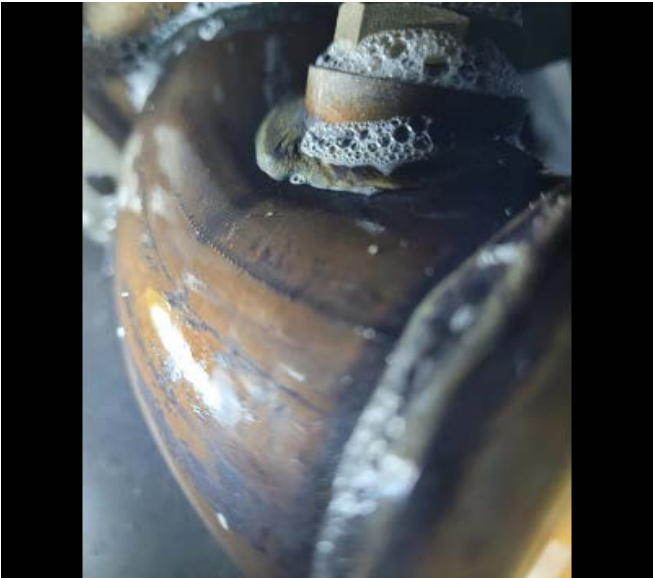

6140936



6140940



6140937

Examples of Normal Exhaust Leak Areas



6289019

Normal backpressure valve shaft seal leakage.



6288860

Normal turbocharger VGT shaft seal leakage.

Version	4
Modified	Released August 12, 2022 Revised September 20, 2022 – Added additional DTCs to Condition section. Revised November 15, 2022 - Added Note between Step 9 and 10 and Added Important Statement after Step 11. Revised March 08, 2023 - Added Examples of Normal Exhaust Leak Areas section.

GM bulletins are intended for use by professional technicians, NOT a "do-it-yourselfer". They are written to inform these technicians of conditions that may occur on some vehicles, or to provide information that could assist in the proper service of a vehicle. Properly trained technicians have the equipment, tools, safety instructions, and know-how to do a job properly and safely. If a condition is described, DO NOT assume that the bulletin applies to your vehicle, or that your vehicle will have that condition. See your GM dealer for information on whether your vehicle may benefit from the information.



WE SUPPORT VOLUNTARY
TECHNICIAN
CERTIFICATION