



# TECHNICAL SERVICE BULLETIN

## Level 3 Charging, Illuminated Charger Service Required Indicator In The IPC And/Or Multiple DTCs

**23-2014**01 March  
2023

This bulletin supersedes 22-2355.

**Model:**

<b>Ford</b> 2022-2023 e-Transit
2022-2023 F-150 Lightning
2021-2023 Mustang Mach-E

**Summary**

This article supersedes TSB 22-2355 to update the vehicle model years affected.

**Issue:** Some 2021-2023 Mustang Mach-E, 2022-2023 e-Transit/F-150 Lightning vehicles may experience inoperative level 3 charging with an illuminated Charger Service Required indicator in the instrument panel cluster (IPC) and diagnostic trouble codes (DTCs) P0D93:00, P0D94:00, P0D98:00, P0D9E:00 and/or P0DA0:00 in the secondary on-board diagnostic module (SOBDM). If the charging cord is removed from the charge port without the lock/release button fully pressed, this can damage the charge port locking pin actuator and disable level 3 charging for the next charging session. To correct the condition, follow the Service Procedure to replace only the charge port lock actuator.

**Action:** Follow the Service Procedure to correct the condition on vehicles that meet all of the following criteria:

- One of the following vehicles:
  - 2021-2023 Mustang Mach-E
  - 2022-2023 e-Transit
  - 2022-2023 F-150 Lightning
- Level 3 charging inoperative
- Illuminated Charger Service Required indicator
- Charge port lock actuator pin broken and/or missing
- At least one of the following DTCs:
  - P0D93:00
  - P0D94:00
  - P0D98:00
  - P0D9E:00
  - P0DA0:00

**Parts**

Service Part Number	Quantity	Description
LJ9Z-10D737-A	1	Actuator Assembly

**Warranty Status:** Eligible under provisions of New Vehicle Limited Warranty (NVLW)/Service Part Warranty (SPW)/Special Service Part (SSP)/Extended Service Plan (ESP) coverage. Limits/policies/prior approvals are not altered by a TSB. NVLW/SPW/SSP/ESP coverage limits are determined by the identified causal part and verified using the OASIS part coverage tool.

**Labor Times**

Description	Operation No.	Time

2022-2023 e-Transit: Inspect And Replace Actuator Following The Service Procedure (Can Be Used With Operation D) (Do Not Use With Any Other Labor Operations Outside Of This Article)	232014A	1.7 Hrs.
2022-2023 F-150 Lightning: Inspect And Replace Actuator Following The Service Procedure (Do Not Use With Any Other Labor Operations)	232014B	1.2 Hrs.
2021-2023 Mustang Mach-E: Inspect And Replace Actuator Following The Service Procedure (Do Not Use With Any Other Labor Operations)	232014C	1.5 Hrs.
2022-2023 e-Transit: Additional Time To Perform 360 Degree Camera Alignment (Can Be Use With Operation A)	232014D	0.7 Hrs.

**Repair/Claim Coding**

Causal Part:	10D737
Condition Code:	01

**Service Procedure**

**NOTE: To prevent repeat concerns with the charge port lock actuator, fully press the charge port lock/release button before disconnecting the charge cord. (Figure 1) The charge port lock actuator may also be released through the vehicle's center display screen or pressing the release button located on the level 3 direct current (DC) fast charger.**

Figure 1



E391533

- For Mustang Mach-E vehicles, refer to the Digital Owner's Manual located in the vehicle's center display screen by selecting Features > Owner's Manual > Charging Your Vehicle > DC Charging > Stopping Charging.
- For e-Transit vehicles, refer to the Digital Owner's Manual located in the vehicle's center display screen by selecting Features > Owner's Manual > Charging Your Vehicle - Electric Motor > DC Charging > Stopping Charging.
- For F-150 Lightning vehicles, refer to the Lightning Digital Owner's Manual located in the vehicle's center display screen by selecting Features > Owner's Manual > Charging Your Vehicle > DC Charging > Stopping Charging.

1. Inspect the charge port lock actuator pin. (Figure 2) Is the charge port lock actuator pin missing or loose?

Figure 2



E391534

- (1). Yes - proceed to Step 2.
  - (2). No - this article does not apply. Refer to Workshop Manual (WSM), Section 414-03B High Voltage Battery Charging System.
2. De-energize the high voltage system. Refer to WSM, Section 414-03A High Voltage Battery > Mounting and Cable > General Procedures.
3. Gain access to the charging port.
- (1). For e-Transit vehicles, remove the front bumper cover. Refer to WSM, Section 501-19 Front Bumper Cover > Bumpers > Disassembly and Assembly.
    - Remove the retainers and the charge port cover. (Figure 3)

Figure 3



(2). For Mustang Mach-E and F-150 Lightning vehicles, remove the following components:

- Left front wheel. Refer to WSM, Section 204-04A Wheels and Tires.
- Fender splash shield. Refer to WSM, Section 501-02 Front End Body Panels > Removal and Installation.
- Charge status indicator (CSI) housing assembly. Refer to WSM, Section 414-03B High Voltage Battery Charging System > Removal and Installation.

4. Disconnect the charge cord lock release cable and 4-way electrical connector to the lock actuator. (Figure 4)

Figure 4

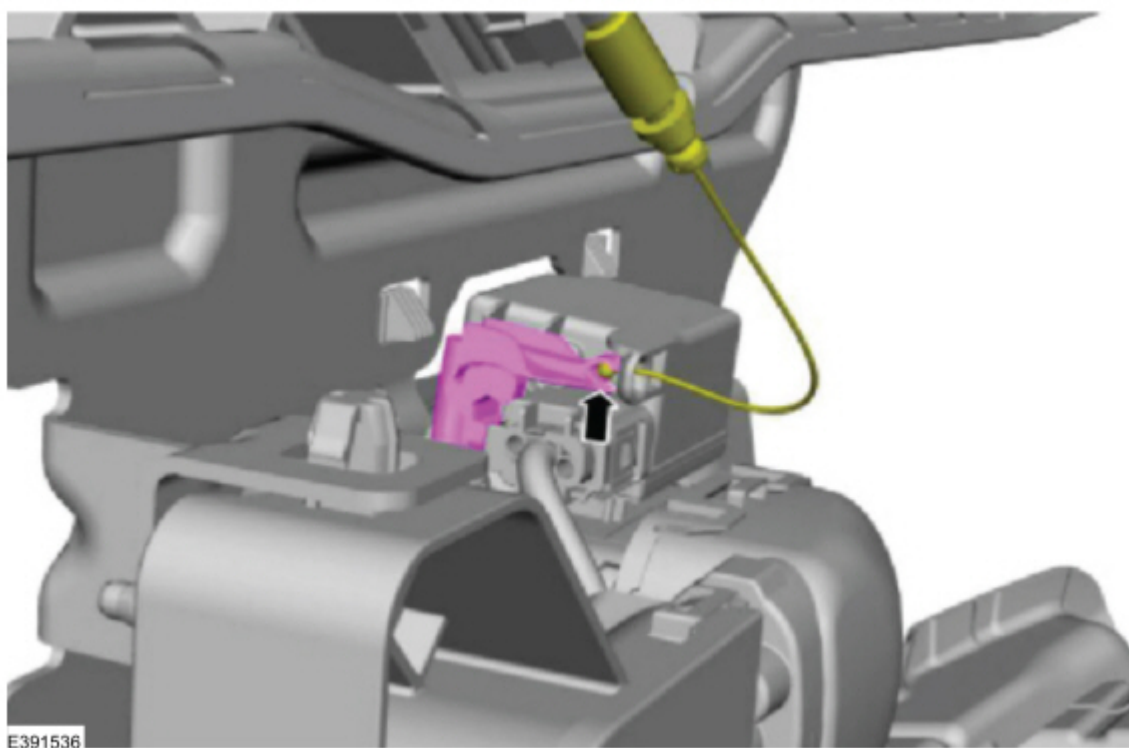

5. Remove the 4 bolts holding the charge port to the body bracket. (Figure 5)

Figure 5

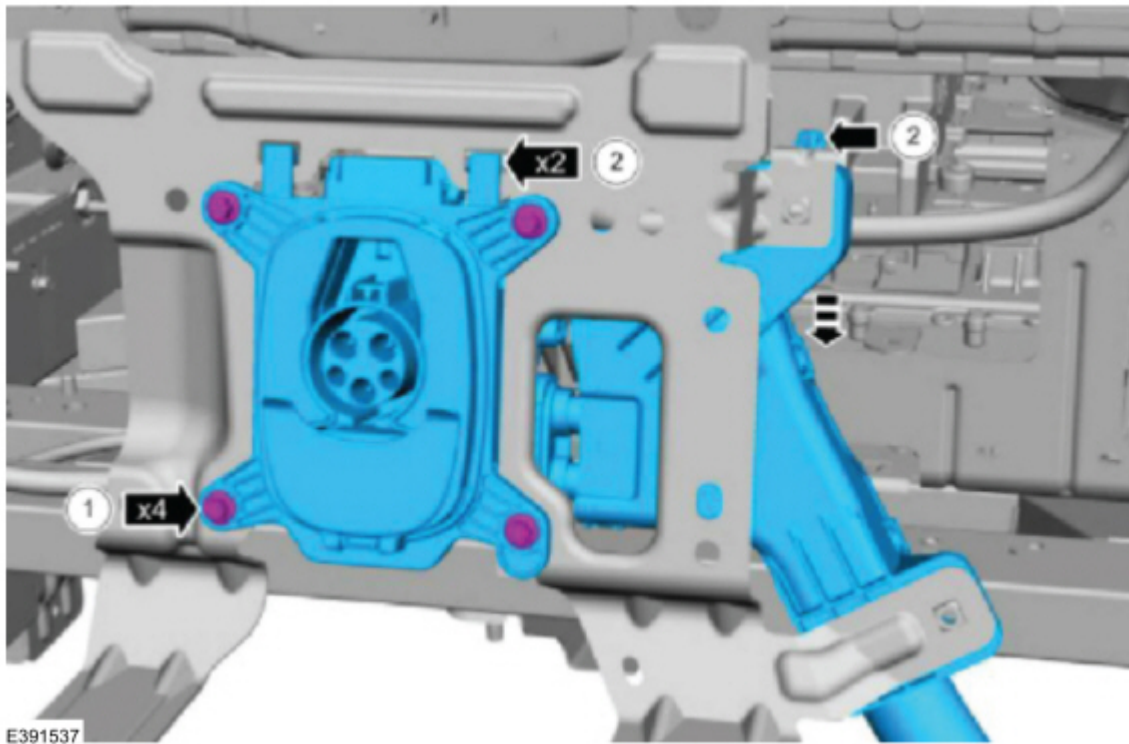

6. Release the 2 snap features and slide the charge port downward along the guide track until there is enough space to remove and discard the 2 actuator bolts and the actuator. (Figure 6)

Figure 6



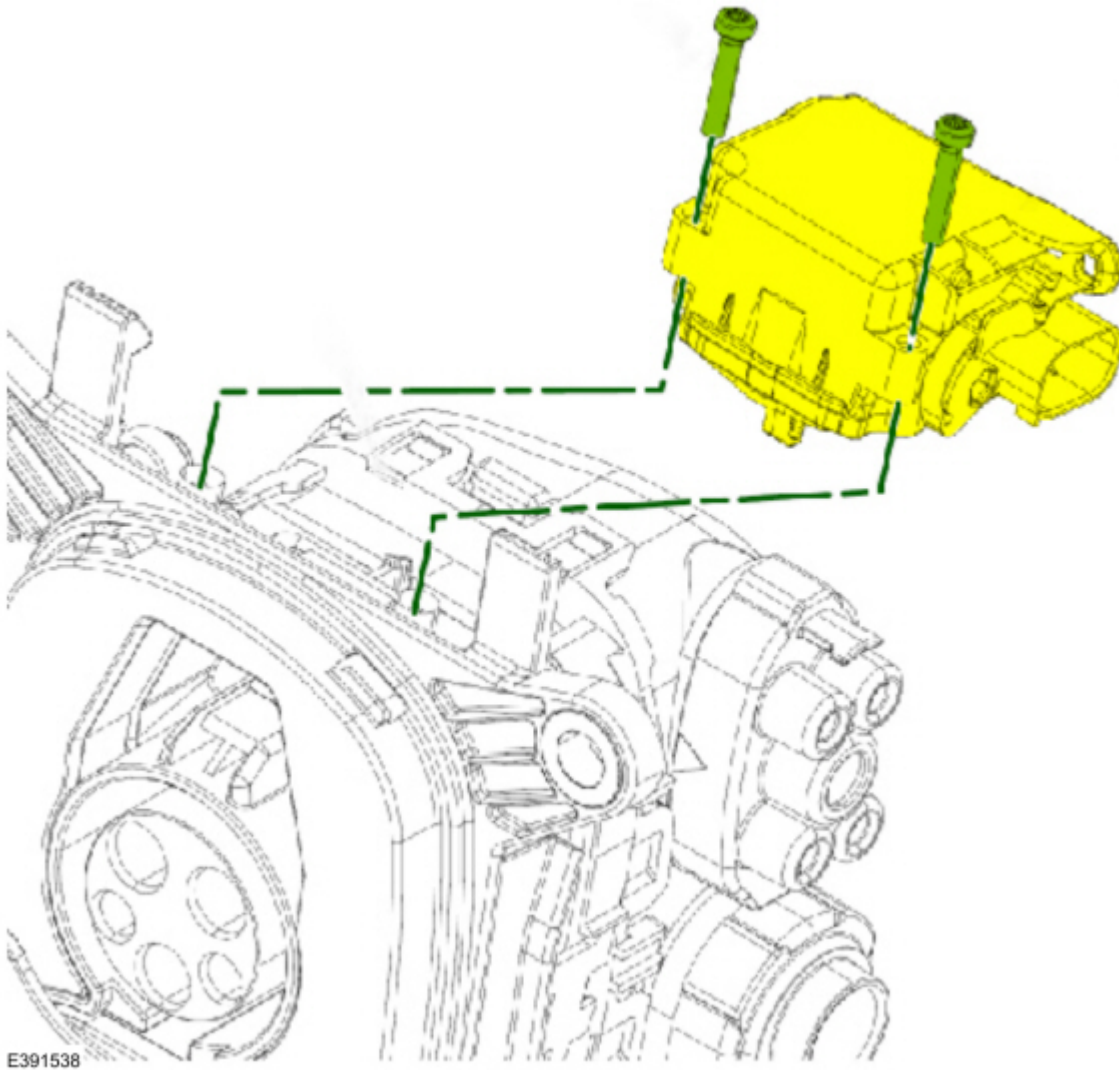

7. Install a new actuator and 2 new actuator bolts. Tighten to 1.2 nm (10.6 lb-in).
8. Align the charge port guides with the bracket. Slide the bracket back into position until the snap features engage, holding the bracket in place with all four holes lined up.
9. Install the 4 charge port bolts. Tighten to 10.5 Nm (93 lb-in).
10. Install the charge cord lock release cable and 4-way electrical connector to the lock actuator. (Figure 4)
11. Install the accessibility components.
  - (1). For e-Transit vehicles, install the retainers and the charge port cover. (Figure 3)
    - Reinstall the front bumper cover. Refer to WSM, Section 501-19 Front Bumper Cover > Bumpers > Disassembly and Assembly.
  - (2). For Mustang Mach-E and F-150 Lightning vehicles, install the following components:
    - Left front wheel. Refer to WSM, Section 204-04A Wheels and Tires.
    - Fender splash shield. Refer to WSM, Section 501-02 Front End Body Panels > Removal and Installation.
    - CSI housing assembly. Refer to WSM, Section 414-03B High Voltage Battery Charging System > Removal and Installation.

© 2023 Ford Motor Company  
All rights reserved.

NOTE: The information in Technical Service Bulletins is intended for use by trained, professional technicians with the knowledge, tools, and equipment to do the job properly and safely. It informs these technicians of conditions that may occur on some vehicles, or provides information that could assist in proper vehicle service. The procedures should not be performed by "do-it-yourselfers". Do not assume that a condition

described affects your car or truck. Contact a Ford or Lincoln dealership to determine whether the Bulletin applies to your vehicle. Warranty Policy and Extended Service Plan documentation determine Warranty and/or Extended Service Plan coverage unless stated otherwise in the TSB article. The information in this Technical Service Bulletin (TSB) was current at the time of printing. Ford Motor Company reserves the right to supersede this information with updates. The most recent information is available through Ford Motor Company's on-line technical resources.