

Technical Service Bulletin



39 All-wheel drive coupling does not work, DTC C111204 stored in the all-wheel drive control module or fuse SC44 blown

39 23 53 2043144/9 April 10, 2023. Supersedes Technical Service Bulletin Group 39 number 22-46 dated February 9, 2022, for reasons listed below.

Model(s)	Year	VIN Range	Vehicle-Specific Equipment
TT, TTS, and TT Roadster	2013 – 2019	All	Not Applicable
TTS Roadster	2013 – 2015		
TT RS	2013 2018 – 2019		
A3, A3 Cabriolet, S3, and Q3	2015 – 2019		
RS 3	2017 – 2019		

Condition

REVISION HISTORY		
Revision	Date	Purpose
9	-	Revised <i>Service</i> (Changed Verbiage of Figure 1) Revised <i>Warranty</i> (Added labor operation for Fuse SC44)
8	02/09/2022	Revised <i>Title</i> (Added Fuse SC44) Revised <i>Condition</i> (Added Fuse SC44 information) Revised <i>Service</i> (Added Fuse SC44 information)
7	07/13/2020	Revised header (Added Model Years 2016 through 2019) Revised <i>Required Parts and Tools</i> (Updated Model Years in Parts Table)

Customer states:

One or both of the following issues are present:

- All-wheel drive does not work.
- The EPC warning lamp is illuminated.

Workshop findings:

The following DTC is stored in the all-wheel drive control module, J492 (address word 0022):

- **DTC C111204** (All Wheel Drive clutch pump faulty).



Or

There is no communication with the all-wheel drive control module, J492 (address word 0022) and fuse SC44 is blown.

Technical Background

There is an internal leak in the hydraulic pump.

Production Solution

Improved hydraulic pump.

Service

1. Before proceeding, confirm that the issue matches the *Condition* exactly.
2. If Fuse SC44 is blown, replace the fuse and continue.
3. Confirm that the propeller shaft from the transmission to the differential is transmitting power to the rear differential.
4. Replace the BorgWarner™ clutch pump according to the Elsa Repair Manual.
5. Replace the high-performance oil for the Borg Warner™ clutch according to the Elsa Repair Manual.
6. Perform all-wheel drive basic settings



Note:

The final drive and the BorgWarner™ clutch have separate oil circuits. Refer to ETKA for information on which oil to use, and refer to the Elsa Repair Manual for draining and filling information.

- The BorgWarner™ clutch uses high-performance oil for clutches, and the final drive uses gear oil.
- The image on the right (Figure 1) shows the correct drain and fill plugs.

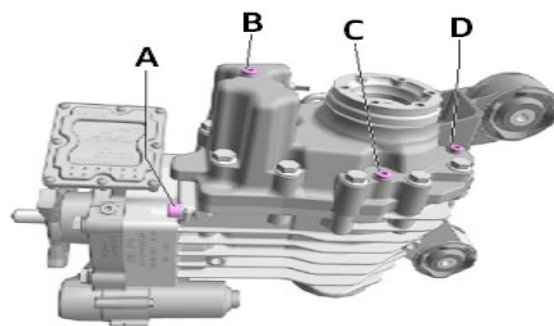

Figure 1. Drain plug for BorgWarner clutch oil (A), oil filler plug for BorgWarner clutch oil (B), gear oil drain plug (C), and oil filler plug for gear oil (D).

Warranty

Technical Service Bulletin



Claim Type:	<ul style="list-style-type: none"> • 110 up to 48 Months/50,000 miles • G10 for CPO vehicles – Verify Owner • If the vehicle is outside any warranty, this Technical Service Bulletin is informational only. 		
Service Number:	3994		
Damage Code:	0040		
Labor Operations:	Pump for AWD remove + reinstall	3994 1900	See SRT
	Replace Fuse SC44 (If necessary)	3994 0199	15TU
Diagnostic Time:	GFF	0150 0000	Time stated on the diagnostic protocol (Max 70 TU)
	Road test prior to service procedure	0121 0002	10 TU
	Road test after service procedure	0121 0004	10 TU
Claim Comment:	As per TSB 2043144/9		

All warranty claims submitted for payment must be in accordance with the *Audi Warranty Policies and Procedures Manual*. Claims are subject to review or audit by Audi Warranty.

Required Parts and Tools

Always check with your Parts Department and/or ETKA for the latest information and parts bulletins.		
Part Number	Part Description	Quantity
TT Model Years 2013-2014		
0AY598549A	Repair kit for primer pump	01
TT and A3 Model Years 2015-2019		
0CQ598549	Repair kit for primer pump	01
Q3 MY 2015		
 Note: Requires a check of the currently installed part!		
0AY598549A	Repair kit for primer pump (Check the installed part # and order the correct replacement part)	01
Or		



0CQ598549		
Q3 MY 2016-2019		
0CQ598549	Repair kit for primer pump	01
All Vehicles		
G 060175A2	High-performance oil for all-wheel drive coupling	01
N 90281802	Seal bolt	01
N 10720201	Bolt with polygon socket head	01
N 91082701	Bolt with hex socket head	01
See ETKA	Fasteners, Bolts, Nuts, and Screws as needed per the Repair Manual	See ETKA/ELSA
See ETKA	Fuse SC44 (If needed)	See ETKA/ELSA

Additional Information

All parts and service references provided in this TSB (**2043144**) are subject to change and/or removal.

©2023 Audi of America, Inc. All rights reserved. The information contained in this document is based on the latest information available at the time of printing and is subject to the copyright and other intellectual property rights of Audi of America, Inc., its affiliated companies, and its licensors. All rights are reserved to make changes at any time without notice. No part of this document may be reproduced, stored in a retrieval system, or transmitted in any form or by any means, electronic, mechanical, photocopying, recording, or otherwise, nor may these materials be modified or reposted to other sites, without the prior expressed written permission of the publisher.