

April 12, 2023

Version 2

Engine Does Not Crank

Supersedes 23-023, dated March 1, 2023, to revise the information highlighted in yellow.

AFFECTED VEHICLES

Year	Model	Trim	VIN Range
2018–23	Odyssey	ALL	ALL
2019–23	Passport	ALL	ALL
2016–20	Pilot	ALL with 9 A/T	ALL
2021–22	Pilot	ALL	ALL
2020–23	Ridgeline	ALL	ALL

REVISION SUMMARY

- Under AFFECTED VEHICLES, the information was updated.
- Under PARTS INFORMATION, the information was updated.
- Under WARRANTY CLAIM INFORMATION, the information was updated.

SYMPTOM

The engine will not crank on initial startup after precipitation and sub-freezing temperatures.

POSSIBLE CAUSE

Water can enter the starter motor, and when temperatures drop below freezing, the water will freeze inside the starter motor. This will prevent the starter from cranking the engine.

CORRECTIVE ACTION

Replace the starter motor assembly if needed.

CUSTOMER INFORMATION:The information in this bulletin is intended for use only by skilled technicians who have the proper tools, equipment, and training to correctly and safely maintain your vehicle. These procedures should not be attempted by "do-it-yourselfers," and you should not assume this bulletin applies to your vehicle, or that your vehicle has the condition described. To determine whether this information applies, contact an authorized Honda automobile dealer.

PARTS INFORMATION

Part Name	Part Number	Quantity
Starter Motor Assembly (All plus 9 A/T Odyssey)	31200-5J2-305	1
Starter Motor Assembly (10 A/T Odyssey)	31200-5MR-305	1
Flange Bolt (12X45)	90165-SDA-A00	2
Flange Bolt (12X120)	90051-5J4-000	1
Power Relay Assembly	39794-T5A-J01	2

TOOLS INFORMATION

Part Name	Part Number	Quantity
Relay Puller	07AAC-000A2A1	1

WARRANTY CLAIM INFORMATION

The normal warranty applies.

Operation Number	Description	Flat Rate Time	Defect Code	Symptom Code	Template ID	Failed Part Number
1161J0	Odyssey 10 A/T: Replace the starter motor assembly and relays (includes inspection).	0.8 hr	01601	03217	A23023A	31200-5MR-A01
1161J0	Pilot: Replace the starter motor assembly and relays (includes inspection).	0.8 hr	01601	03217	A23023B	31200-5J2-A53
1161J0	Passport, Ridgeline: Replace the starter motor assembly and relays (includes inspection).	0.9 hr	01601	03217	A23023C	31200-5J2-A53
1161J0	Odyssey 9 A/T: Replace the starter motor assembly and relays (includes inspection).	0.8 hr	01601	03217	A23023D	31200-5J2-A53

INSPECTION PROCEDURE

1. Confirm that the engine does not crank.
2. Inspect the starter motor, if you find evidence of icing on or around the starter motor, warm up the starter motor either by gently applying heat or allowing the vehicle to thaw inside the shop environment.
3. After the thawing period, attempt to crank/start the engine.
 - If the engine starts, go to REPAIR PROCEDURE.
 - If the engine doesn't crank/start, continue with normal troubleshooting.

REPAIR PROCEDURE

Odyssey

1. Open the hood.
2. Remove the front bulkhead cover.
3. Remove the air intake duct/air cleaner.

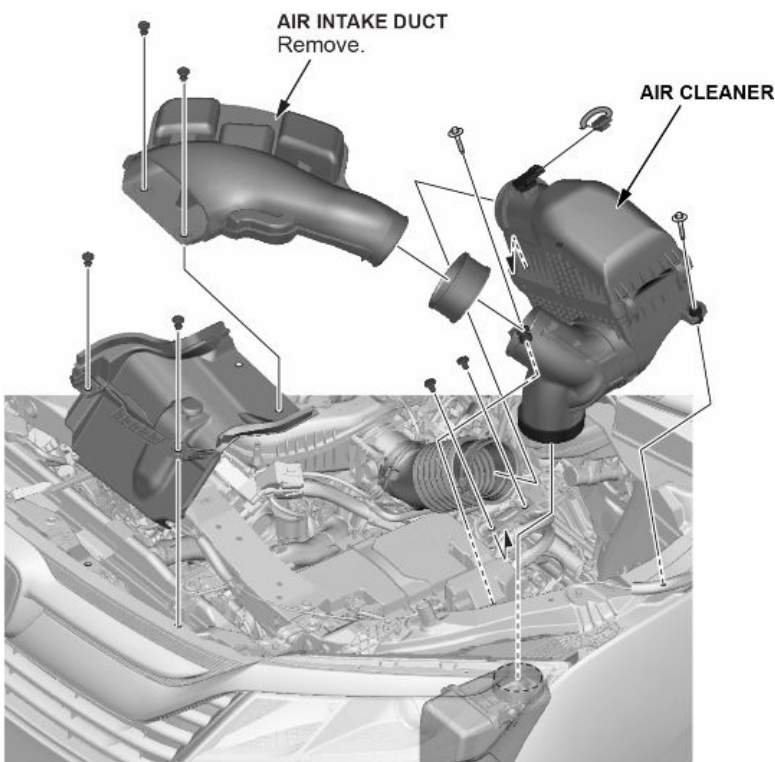

4. Remove the 12 volt battery.
 - 4.1. Make sure the vehicle is in the OFF (LOCK) mode.
 - 4.2. Disconnect and isolate the negative cable with the 12 volt battery sensor from the 12 volt battery.

NOTE:

 - Always disconnect the negative side first.
 - To protect the connector from damage, do not hold it when removing the terminal.
 - Do not disconnect the 12 volt battery sensor from the cable.
 - 4.3. Open the terminal cover.

4.4. Disconnect the terminal from the 12 volt battery.

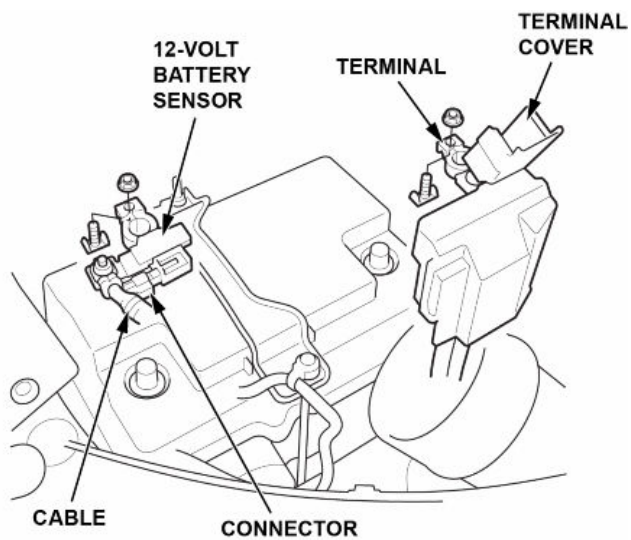

5. Remove the 12 volt battery setting plate.

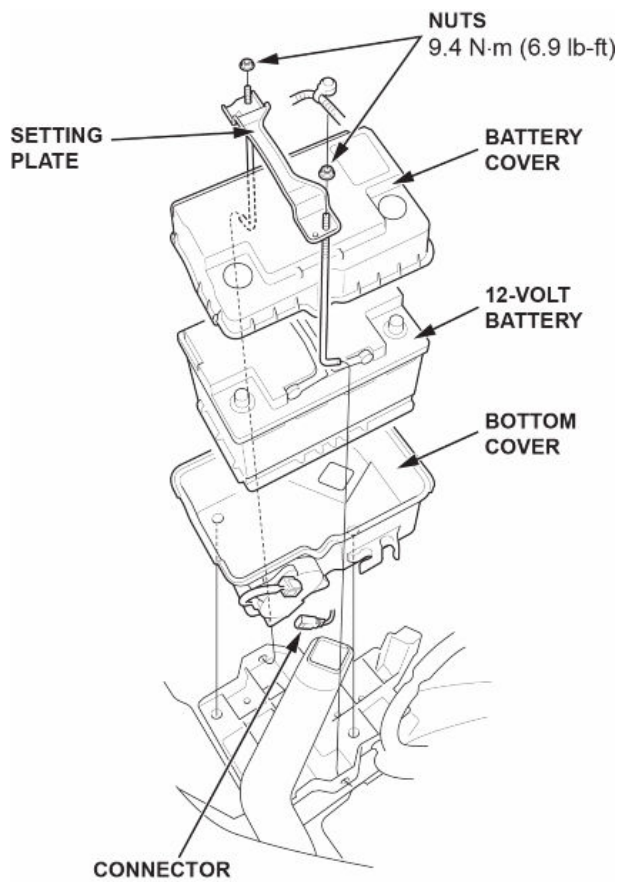

6. Remove the 12 volt battery cover.

7. Remove the 12 volt battery.

8. Disconnect the connector.

9. Remove the 12 volt battery bottom cover.

10. Remove the skid block.

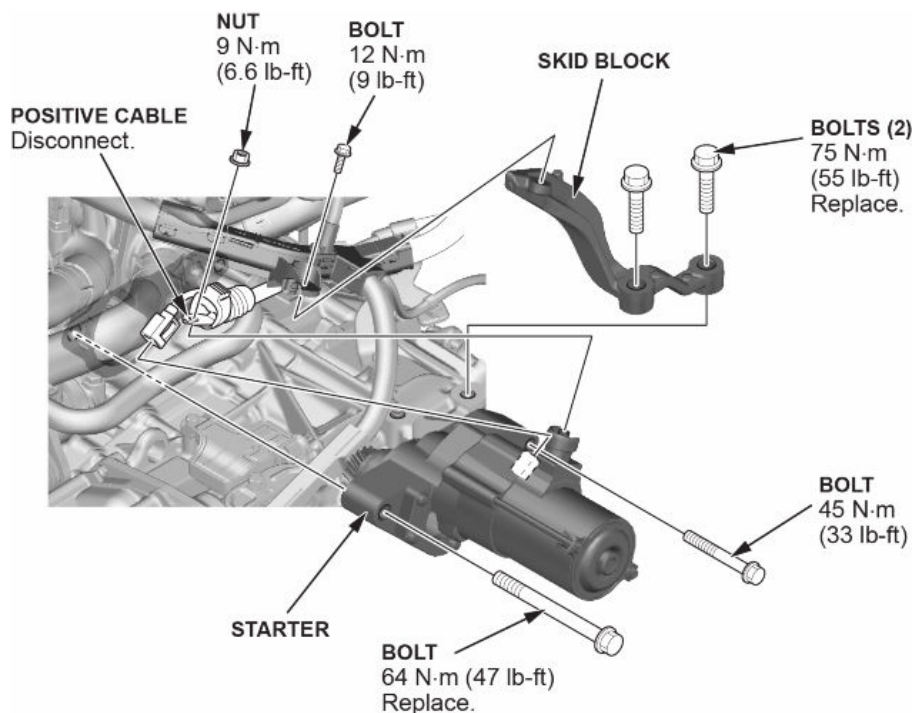

11. Disconnect the positive cable.

12. Remove the starter assembly.

NOTE: Make sure the crimped side of the ring terminal faces away from the starter when you connect the positive cable.

13. Install the new starter assembly and all remaining parts in the reverse order of removal.

14. Replace starter cut relay 1 and starter cut relay 2.

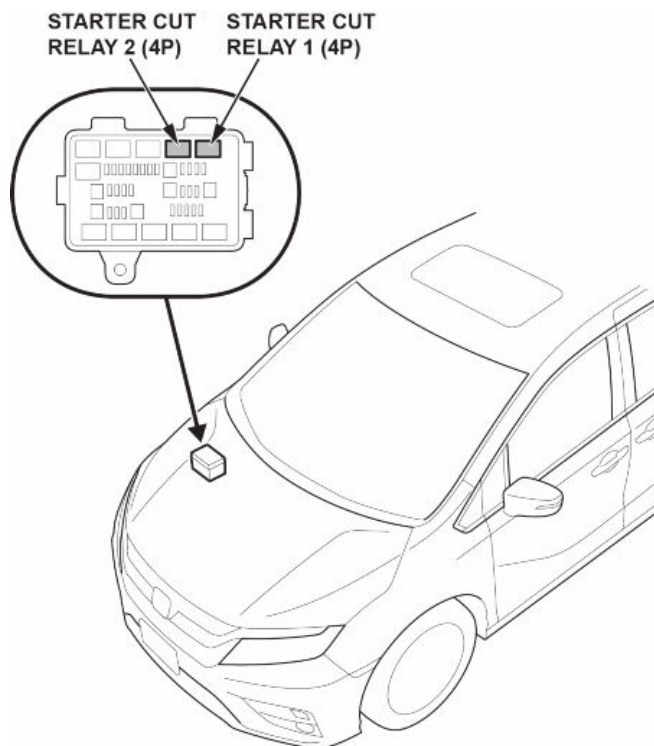

15. Connect the HDS to the DLC.

NOTE: Make sure the HDS is loaded with the latest software version.

16. Turn the vehicle to the ON mode.

17. Select **IDLE STOP STARTER COUNTER CLEAR** in the ADJUSTMENT MENU with the HDS.

Passport, Pilot, Ridgeline

1. Remove the front bulkhead cover.

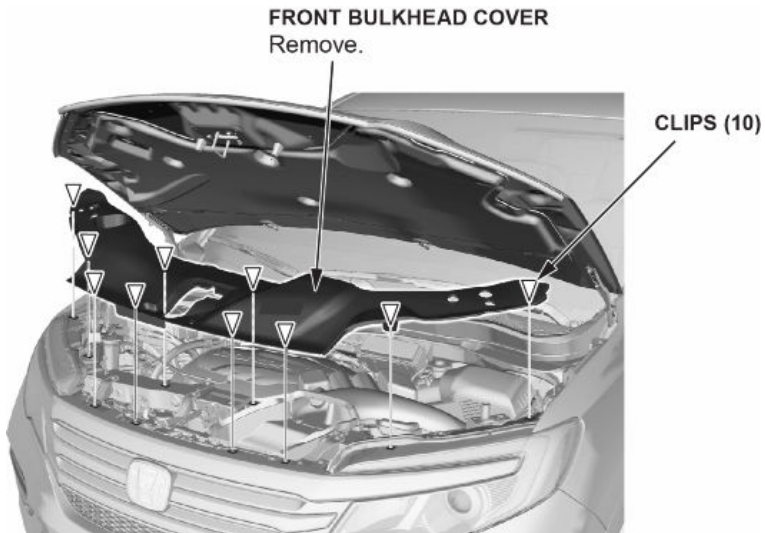

2. Remove the air intake tube.

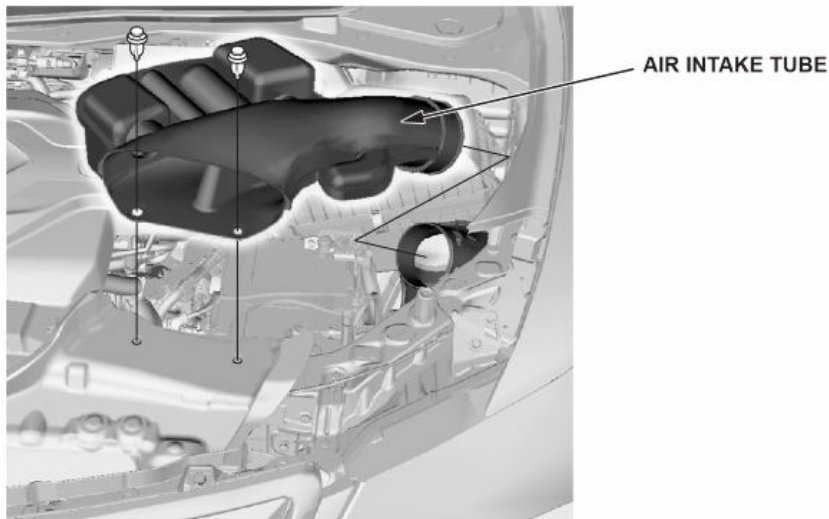

3. Remove the air cleaner.
 - 3.1. Disconnect the connector.
 - 3.2. Remove the clips.
 - 3.3. Remove the air cleaner.

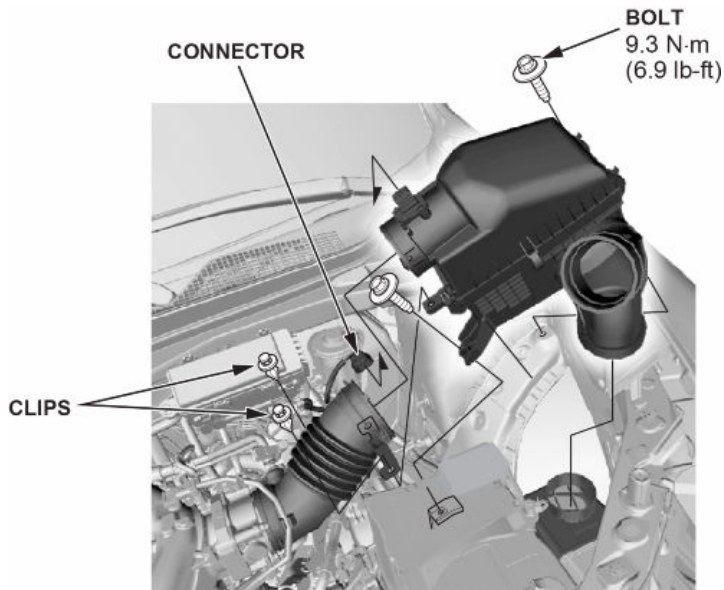

4. Disconnect the 12 volt battery terminal.
 - 4.1. Make sure the vehicle is in the OFF (LOCK) mode.
 - 4.2. Disconnect and isolate the negative cable with the 12 volt battery sensor from the 12 volt battery.

NOTE:

 - Always disconnect the negative side first.
 - To protect the 12 volt battery sensor connector from damage, do not hold it when removing the negative terminal.
 - Do not disconnect the 12 volt battery sensor from the negative terminal.
 - 4.3. Open the cover.

NOTE: If necessary, remove the cover.
 - 4.4. Disconnect the positive cable and the 12 volt battery terminal from the 12 volt battery.

5. Remove the 12 volt battery.

5.1. Remove the 12 volt battery setting plate (A) and the 12 volt battery.

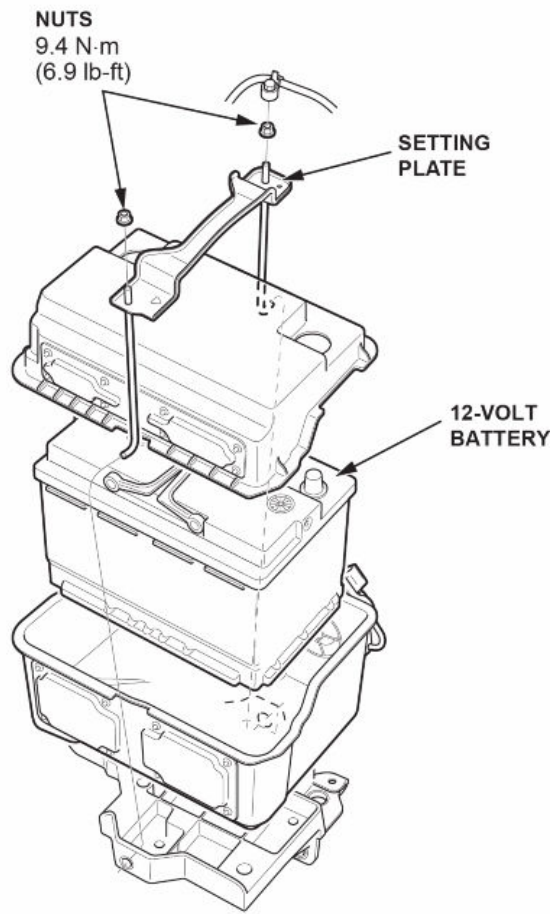

6. Remove the 12 volt battery box.
 - 6.1. Disconnect the connector.
 - 6.2. Remove the 12 volt battery fan motor from the 12 volt battery box.

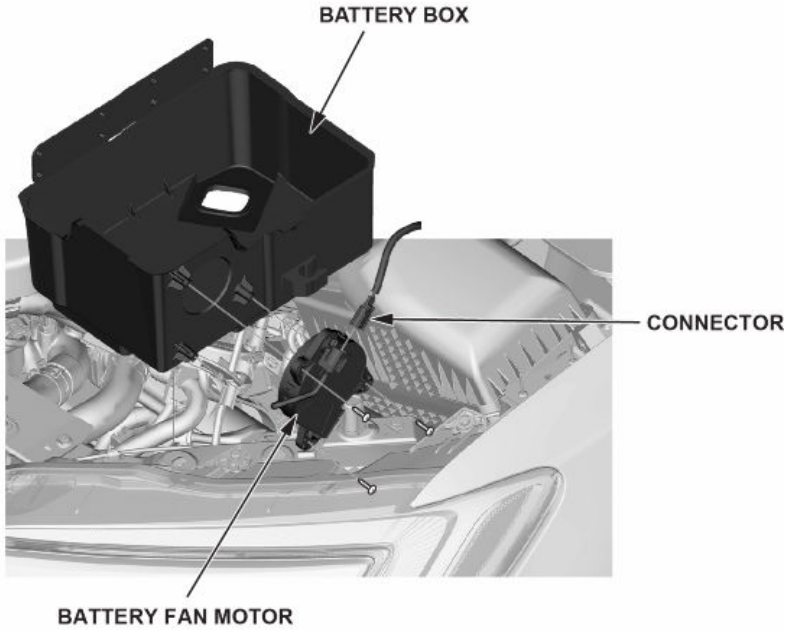

7. Move the harness holder.
 - 7.1. Remove the connector clamp.
 - 7.2. Move the harness holder,

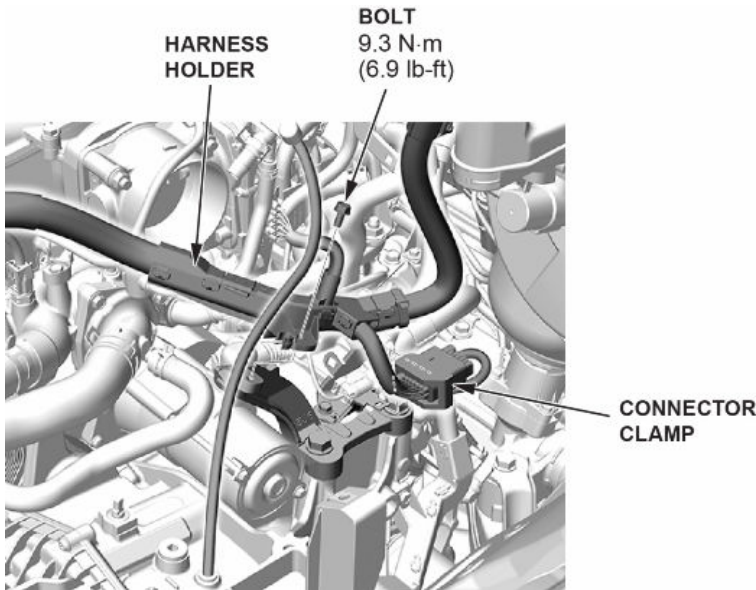

8. Remove the skid block.

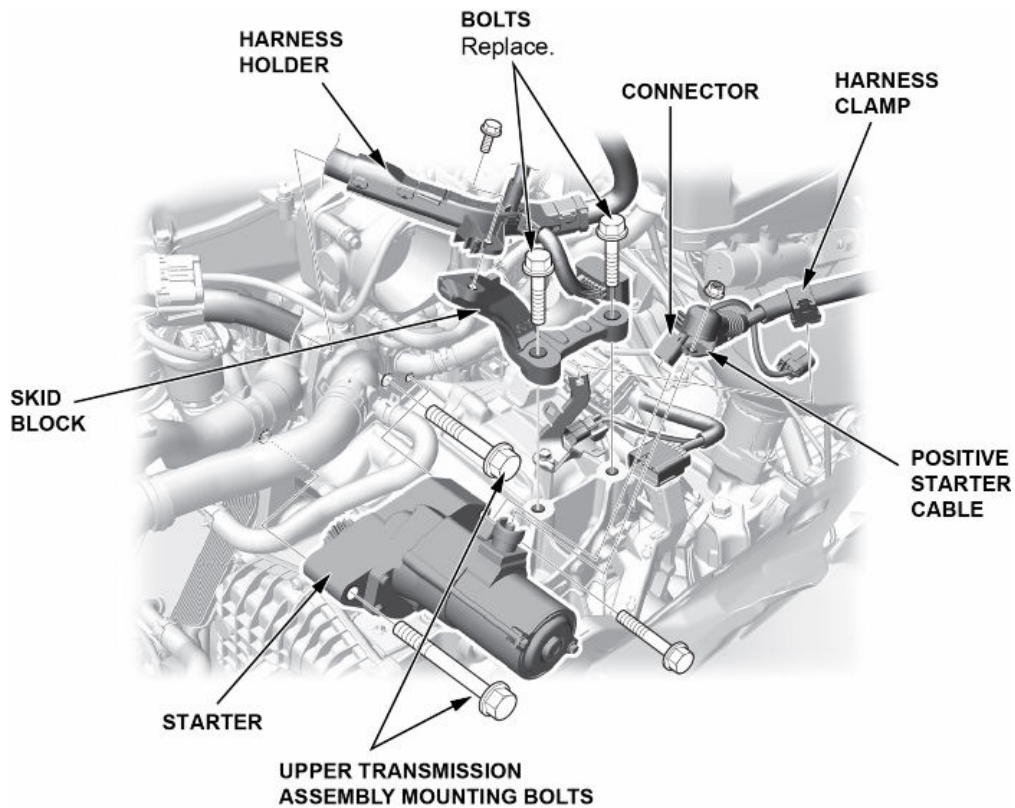

9. Remove the harness clamp.

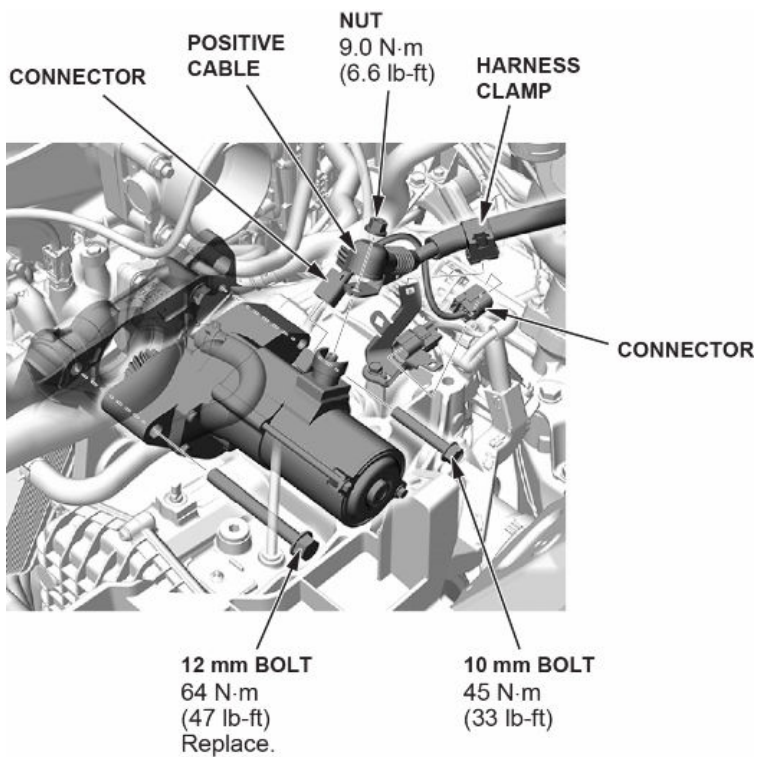

10. Disconnect the positive cable and the connectors.

11. Remove the starter.

12. Install the new starter assembly and all remaining parts in the reverse order of removal.

13. Replace the starter cut relay 1 and starter cut relay 2.

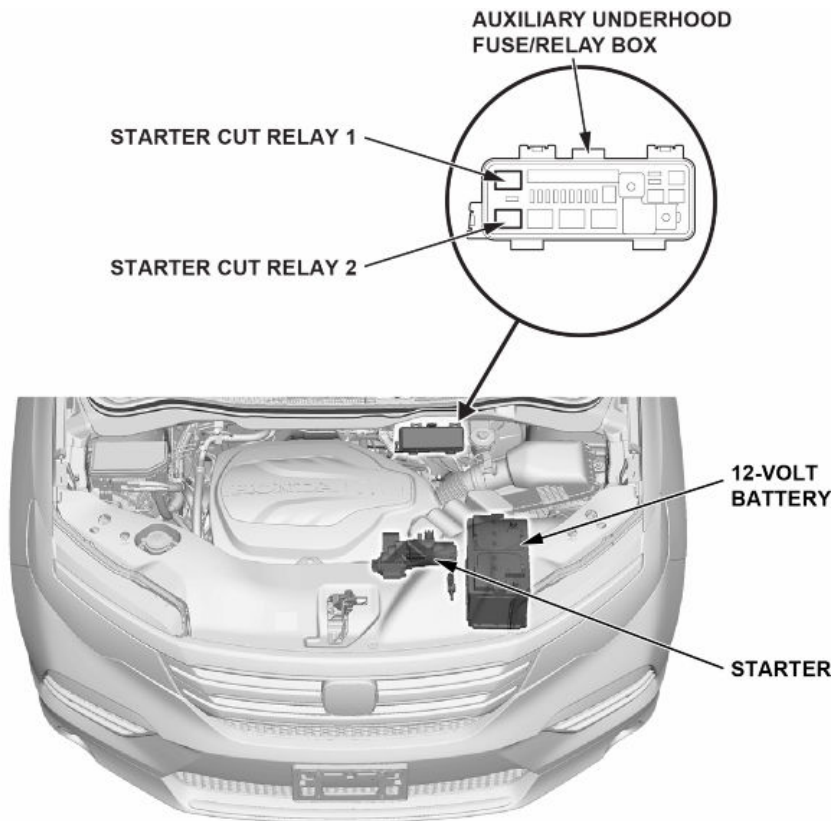

14. Clear the starter counter.

14.1. Connect the HDS to the DLC.

NOTE: Make sure the HDS is loaded with the latest software version.

14.2. Turn the vehicle to the ON mode.

14.3. Select **IDLE STOP STARTER COUNTER CLEAR** in the **ADJUSTMENT MENU** with the HDS.

END