



Technical Journal

TITLE:
Replacement of ERAD components

REF NO: TJ 33358.5.0	ISSUING DEPARTMENT: Technical Service	CAR MARKET: United States and Canada	
PARTNER: 3 US 7510 Volvo Car USA		ISSUE DATE: 2018-09-10	STATUS DATE: 2018-09-18
FUNC GROUP: 4600	FUNC DESC: Rear axle, drive shaft	Page 1 of 22	

“Right first time in Time”

Attachment

File Name	File Size
PN 32240142.JPG	0.1042 MB
TJI-509127-1_1_2_en-US.pdf	6.1224 MB

Vehicle Type

Type	Eng	Eng Desc	Sales	Body	Gear	Steer	Model Year	Plant	Chassis range	Struc Week Range
238	BC	B1BPHEV					2018-2018		-	201718-201744
238	BR	B1FPHEV					2018-9999		-	201746-209952
246	BR	B1FPHEV					2018-9999		-	201717-209952
256	BC	B1BPHEV					2016-9999		-	201526-209952
256	BR	B1FPHEV					2018-9999		-	201717-209952

CSC Customer Symptom Codes

Code	Description
YR	Drive mode "AWD"/Disengages automatically/Not available
56	Drive mode "OFF ROAD"/Disengages automatically/Not available
53	Driving, Twin Engine/Propulsion using electric motor not possible
55	Driving, Twin Engine/Propulsion using combustion engine/Always active/Active too often
AJ	Driving/Poor performance/lacks power
DL	Warning lights and chimes/Malfunction Indicator Light ("Check engine" light) indication/no indication
8N	Driving/Unusual noise/Unsure when/at all times
D2	Front/rear axle/Unusual noise



VST Operation Number

VST Operation Number	Description
98210-2	ERAD transmission, replacement

DTC Diagnostic Trouble Codes

Control Module	Code	Fault Type
IEM	P286F00	Intermittent
IEM	P286D00	Intermittent

Rows beginning with * are modified

Note! If using a printed copy of this Technical Journal, first check for the latest online version.

Text

DESCRIPTION:

To determine if the transmission or the complete ERAD needs to be exchanged follow instructions under “Service”.

Instructional film is included as [attachment, mp4](#).

The repair method is included as attachment, pdf.

* Note: The ERAD (Electrical Rear Axle Drive) can almost always be repaired by replacing only the transmission. The complete ERAD rarely needs to be replaced.

SERVICE:

* If the customer is driving in electric mode and experiences noise from the rear that increase with vehicle speed (that corresponds to the electrical motor speed), such as whining or howling, it is an electrical motor issue.

In this case the complete ERAD is to be exchanged. No DTC(s) are set for this issue.

If the customer experiences hesitation when the electrical motor should be engaged or no electrical motor engagement at all, the transmission part needs to be exchanged.

This fault may result in Clutch DTC(s) as indicated in the list, and a possible message in DIM (Driver Information Module) “Hybrid system failure, Service required”.

*ERAD transmission is ordered according to normal routines, Prior Approval is not necessary. ERAD transmission Part No. 32240142.

Note: Transmission oil is necessary to complete the repair and is not included in the repair kit. Please order in accordance with VIDA.

VEHICLE REPORT:

Yes, please submit a Vehicle Report if the service solution described in this TJ has no effect. Use concern area “Vehicle Report” and sub concern area “Support not needed”, use function group 4600.

To view TJ attachment continue to next page. This TJ has two attachments.





Title	ERAD transmission	Page	1 (19)
Action	Replacement	Operation number:	98210-2

Issue	Date	Reason
1	2018-01	First issue

Affected vehicles

Model year	Model	Engine	Transmission
2018	S90 (17-)	B4204T28, T35	TG-81SC
2018	S90L	B4204T28, T35	TG-81SC
2018	V90 (17-)	B4204T35	TG-81SC
2018	XC60 (18-)	B4204T28, T34, T35	TG-81SC
2016, 2017, 2018	XC90 (16-)	B4204T28, T34, T35	TG-81SC

Materials

Materials	Qty.	Part No.	Notes
Strip clamp	1.0	983750	

Special tools

Description	Part No.
Fixture	999 7689
FLOOR STAND (TO FIXTURES)	999 2520

Equipment

Designation	Part No.
Plastic mallet	
Circlip pliers, internal	

Color symbols

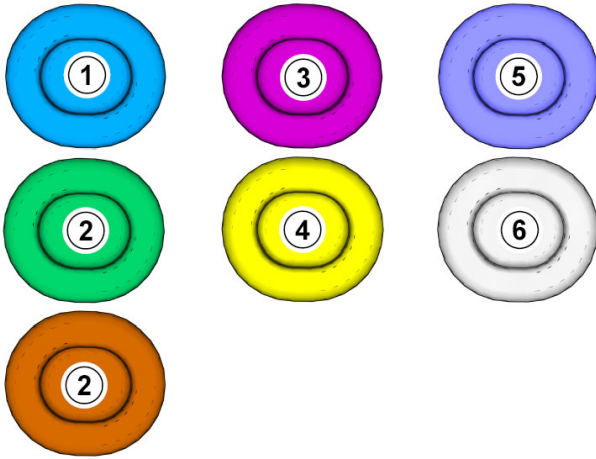

Note! This colour chart displays (in colour print and electronic version) the importance of the different colours used in the images of the method steps.

- 1 . Used for focused component, the component with which you will do something.
- 2 . Used as extra colors when you need to show or differentiate additional parts.
- 3 . Used for attachments that are to be removed/installed. May be screws, clips, connectors, etc.
- 4 . Used when the component is not fully removed from the vehicle but only hung to the side.
- 5 . Used for standard tools and special tools.
- 6 . Used as background color for vehicle components.

Removal

Follow instructions for lifting points body frame , refer to:

- Specifications, mechanical
- 8 - Body and interior
- 81 - Body frame
- 810 - general

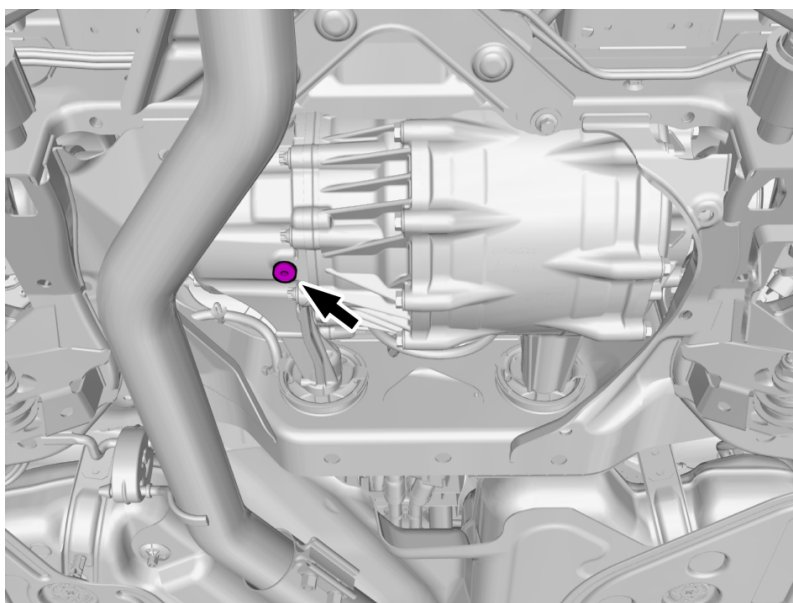

Warning! Be prepared to collect escaping fluid.

Remove the screw.

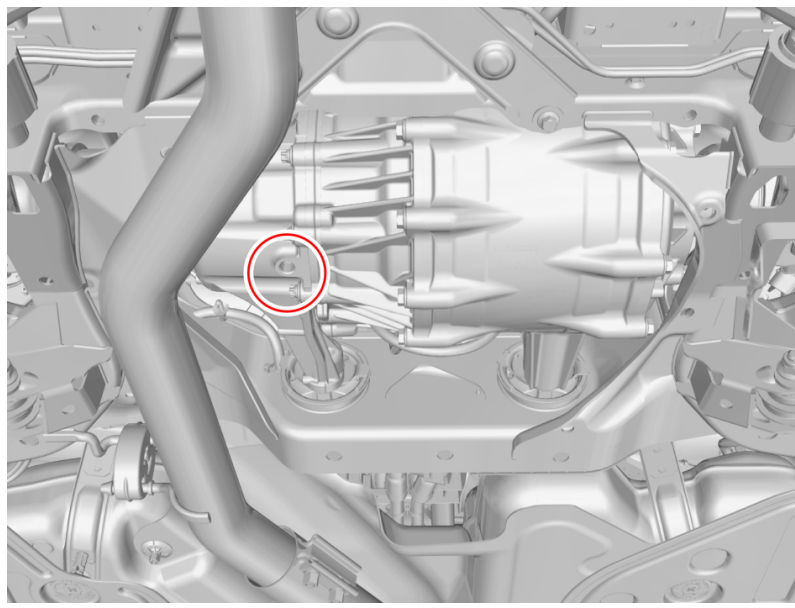

Caution! The fluid must be allowed to escape until a continuous flow changes into single drops.

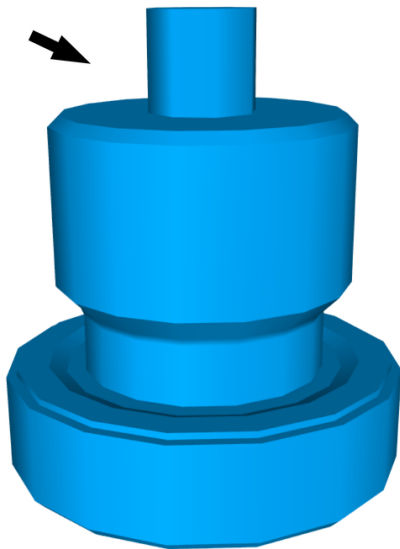

Note! Make sure that the component is clean and free of foreign material.

Remove the swarf.

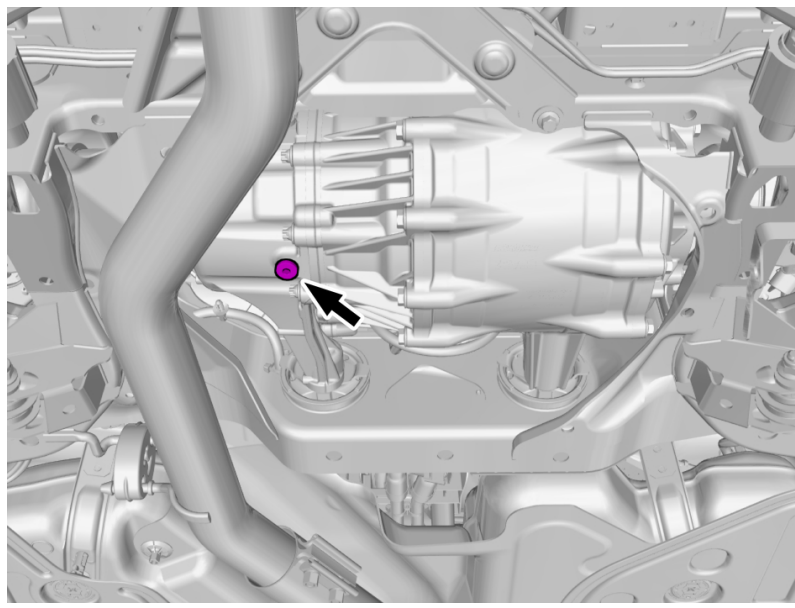

Install the screw.

Torque:

ERAD Oil drain plug , 20 Nm

Remove rear axle, electric erad , refer to:
Removal, replacement and installation
4 - Power transmission
46 - Rear axle, drive shafts
465 - final drive (front and rear)

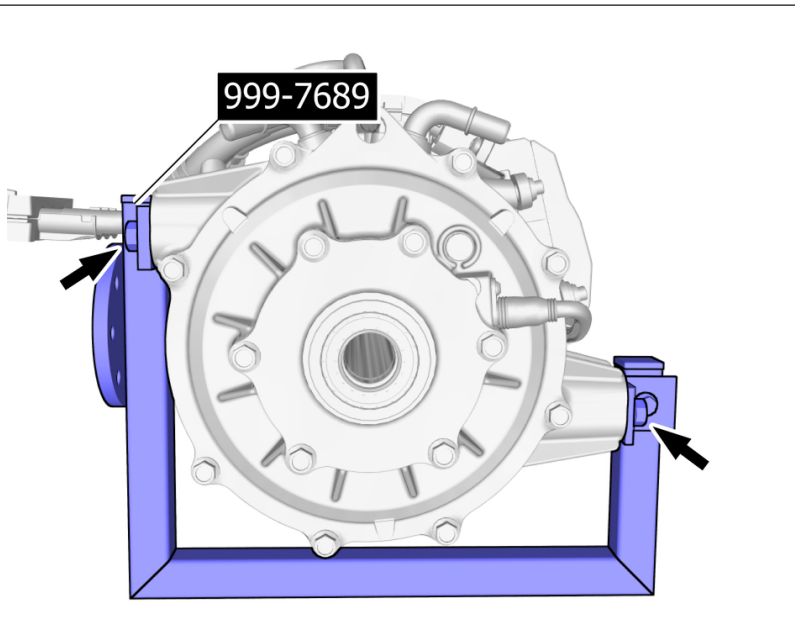

Special Tool: T9997689, Fixture

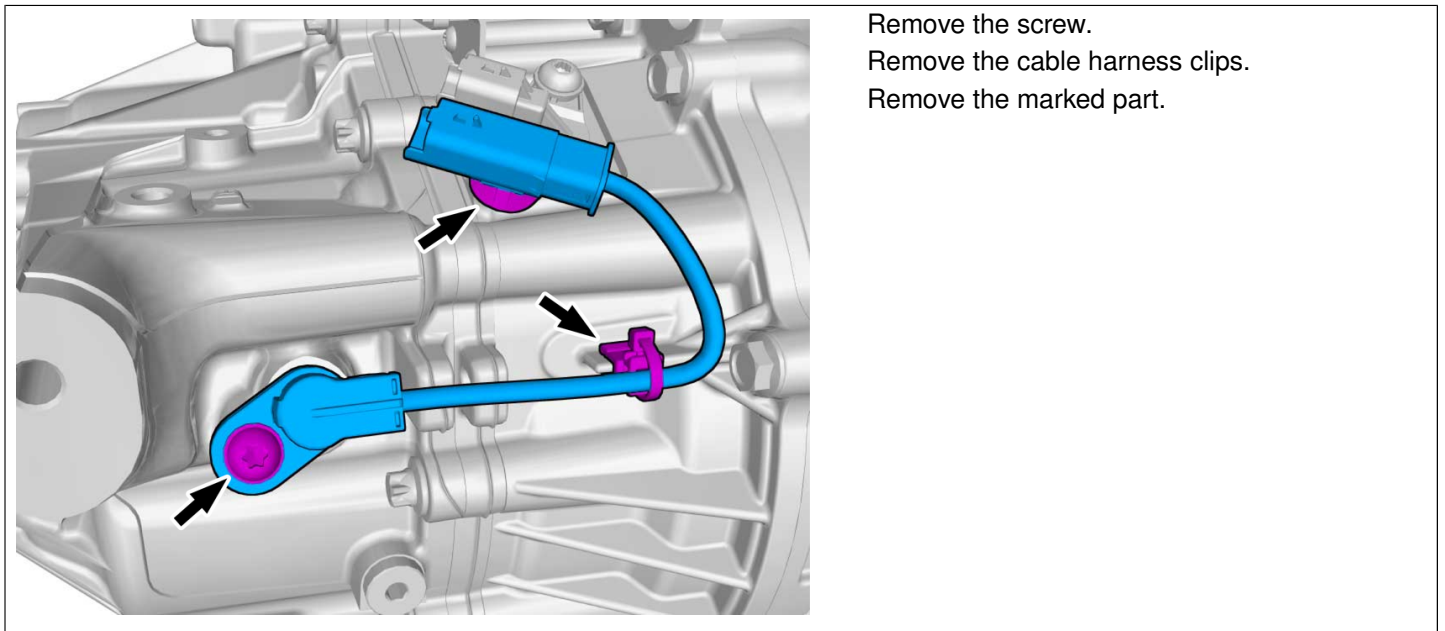
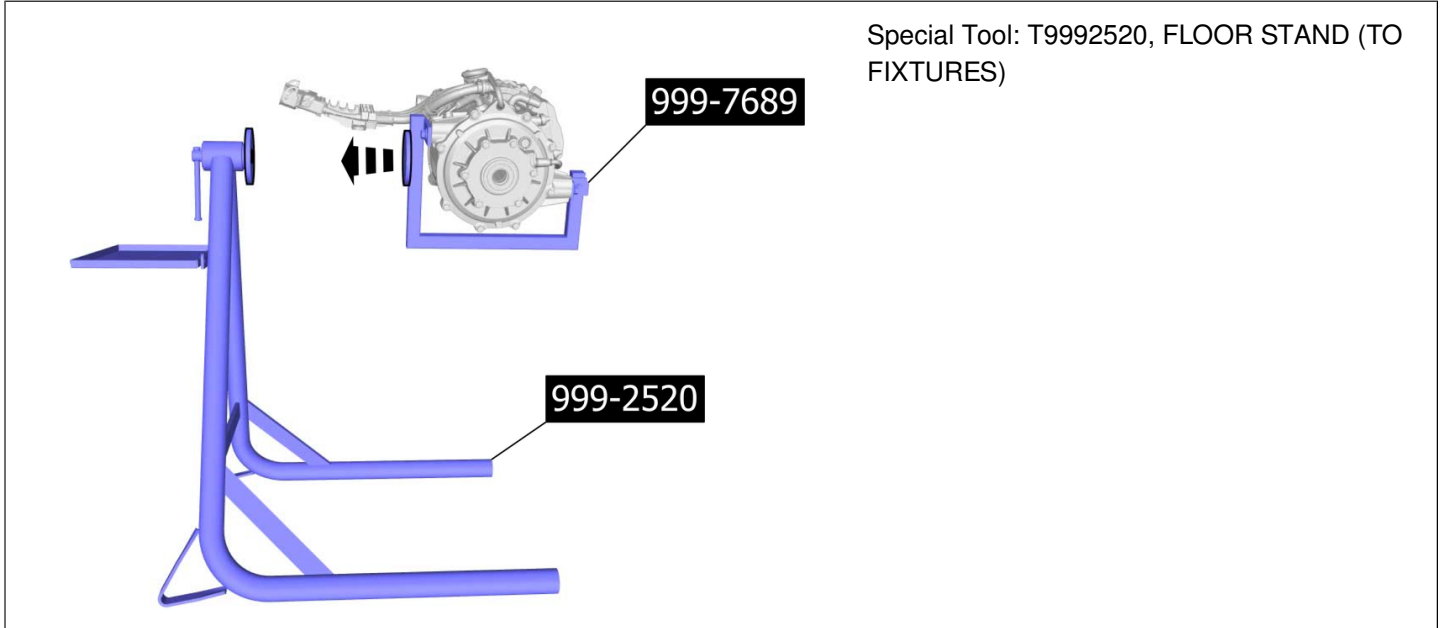

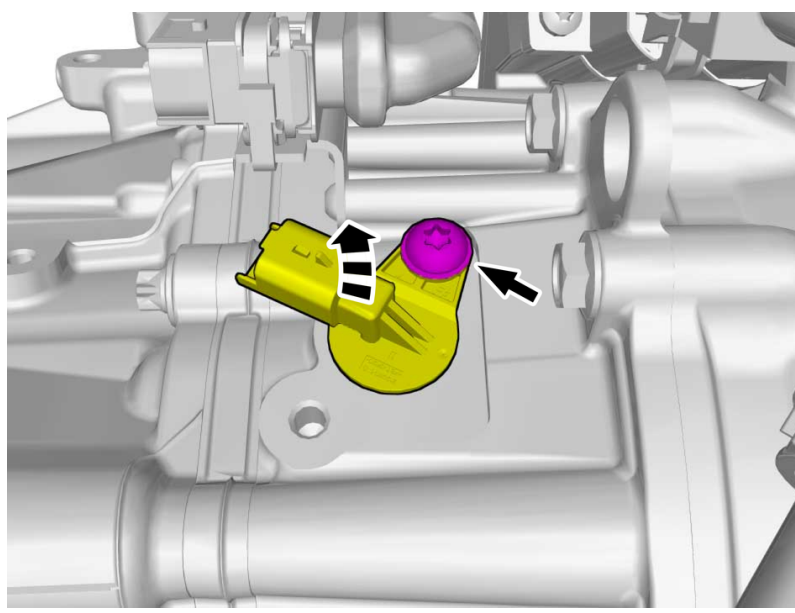

Remove the screw.
Lift the marked component up

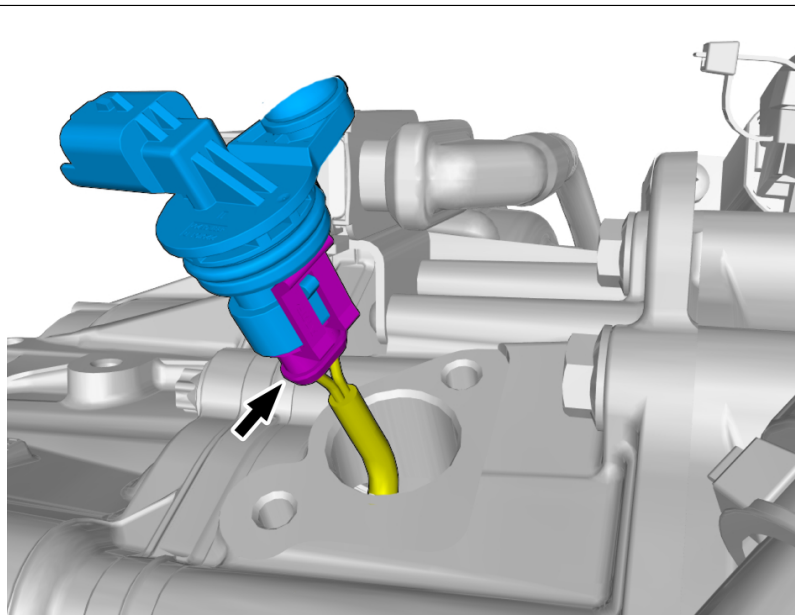

Disconnect the connector.
Remove the marked part.

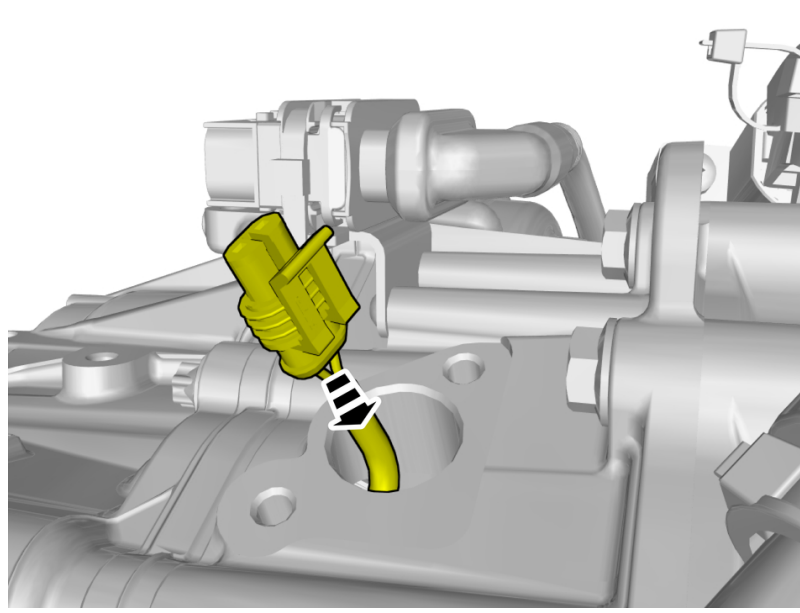

Fold marked part to one side.

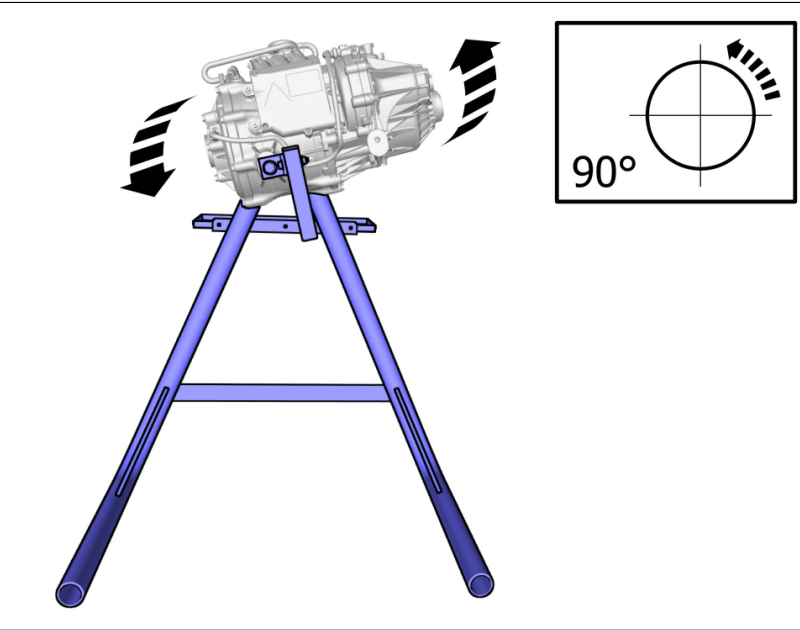

Turn the engine

Remove the screws.

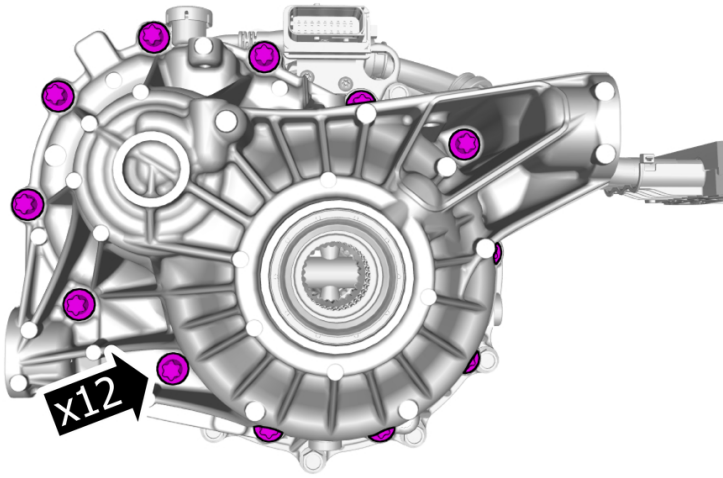

Note! Make sure that locating studs remains in the timing gear casing.

Remove the marked part.

Use: Plastic mallet

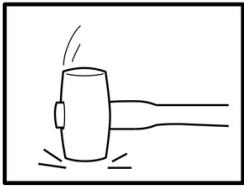
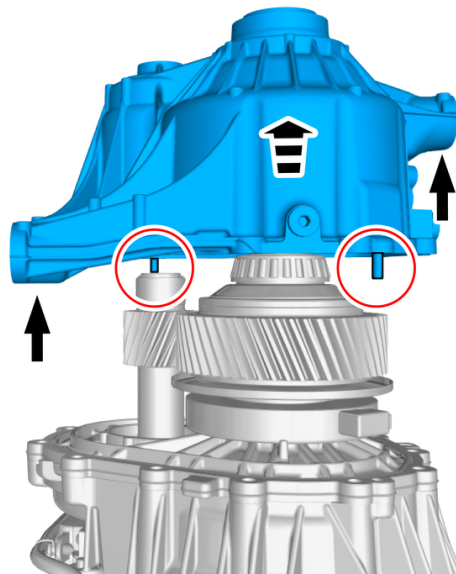

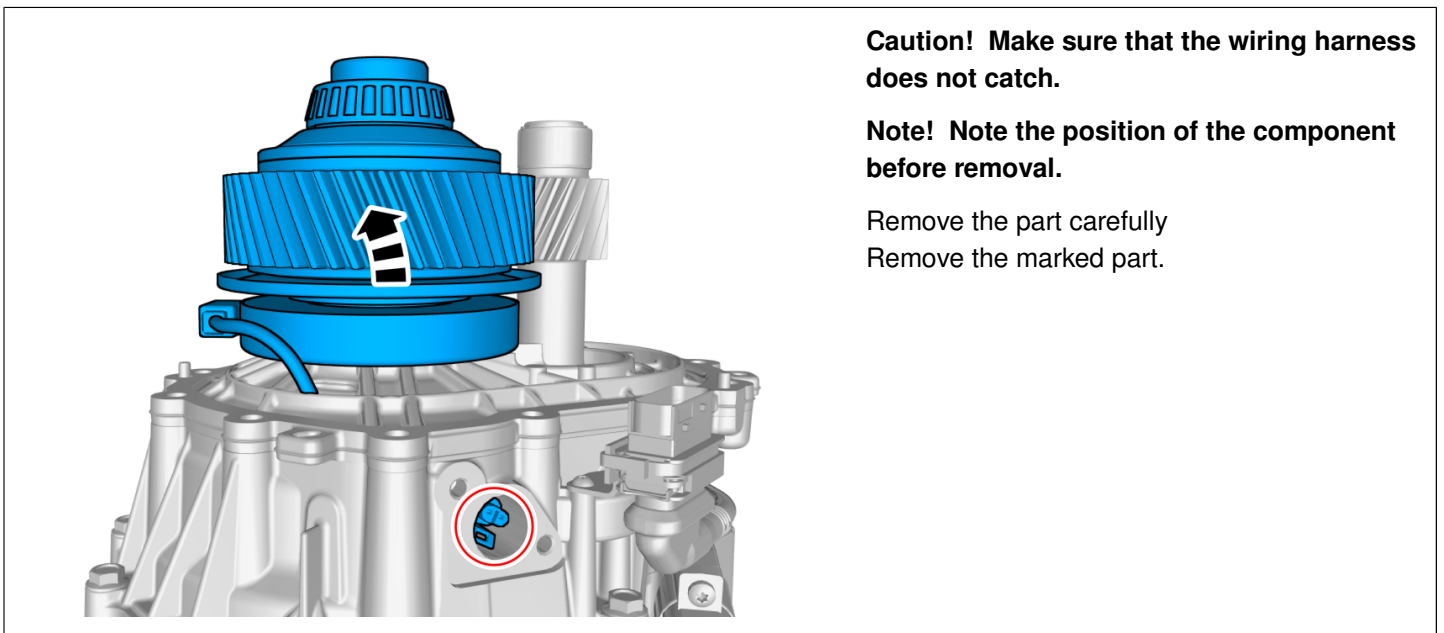
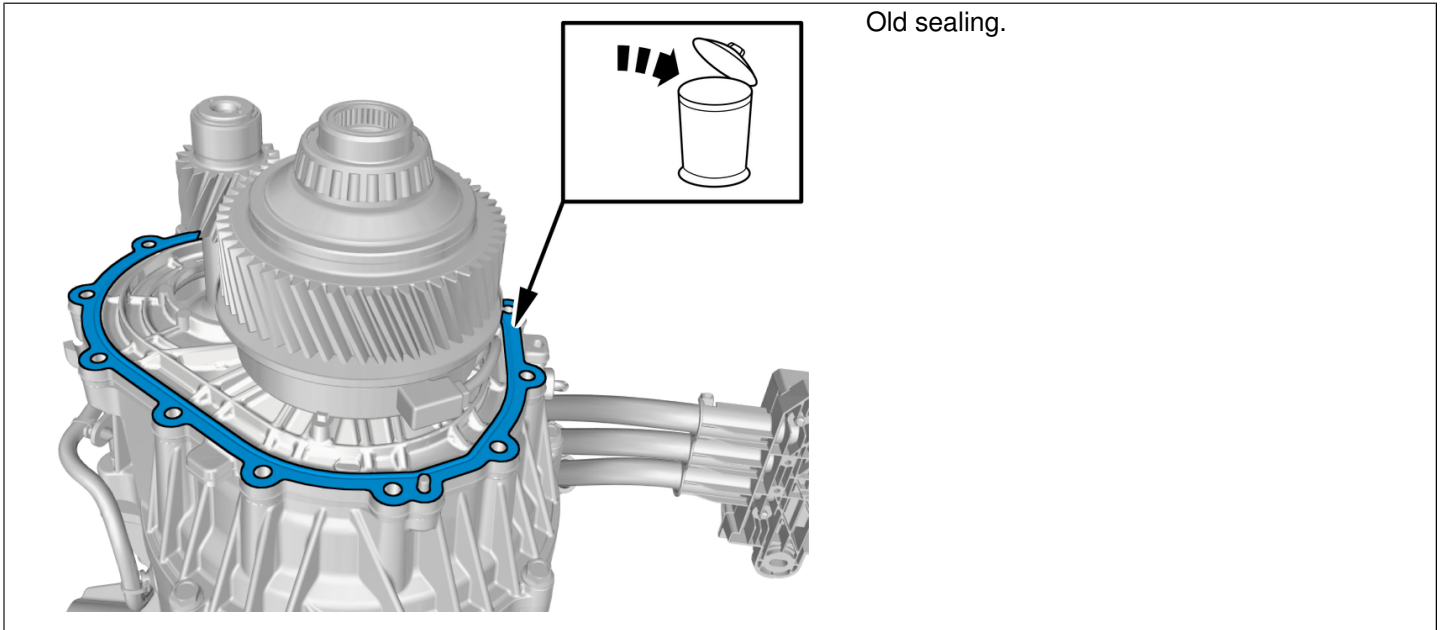

Remove the marked part.

Use: Plastic mallet

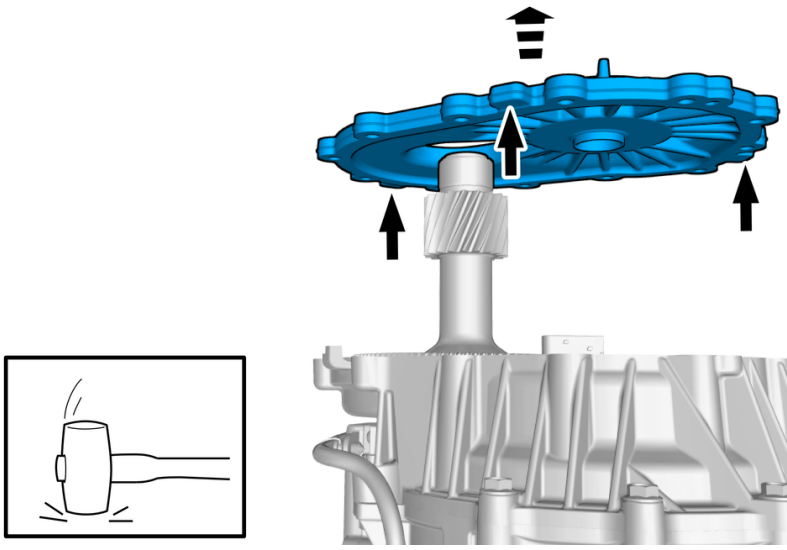

Old sealing.

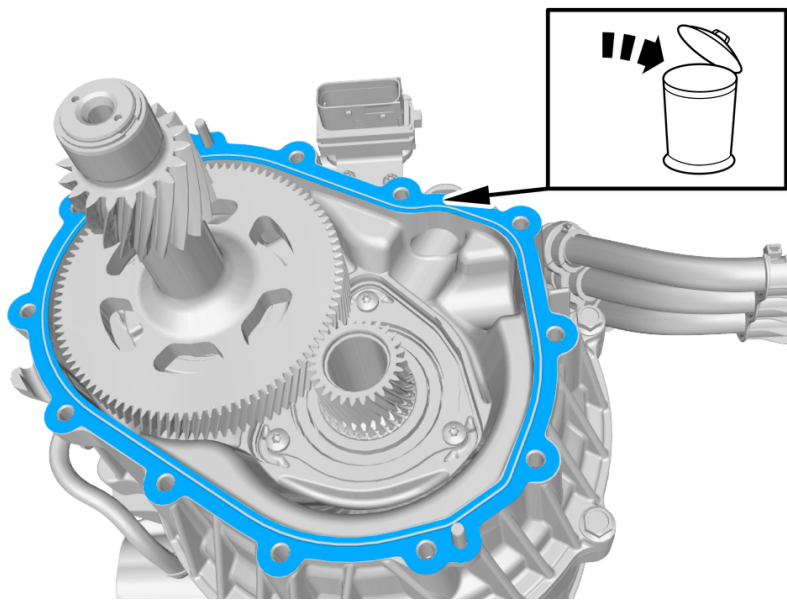

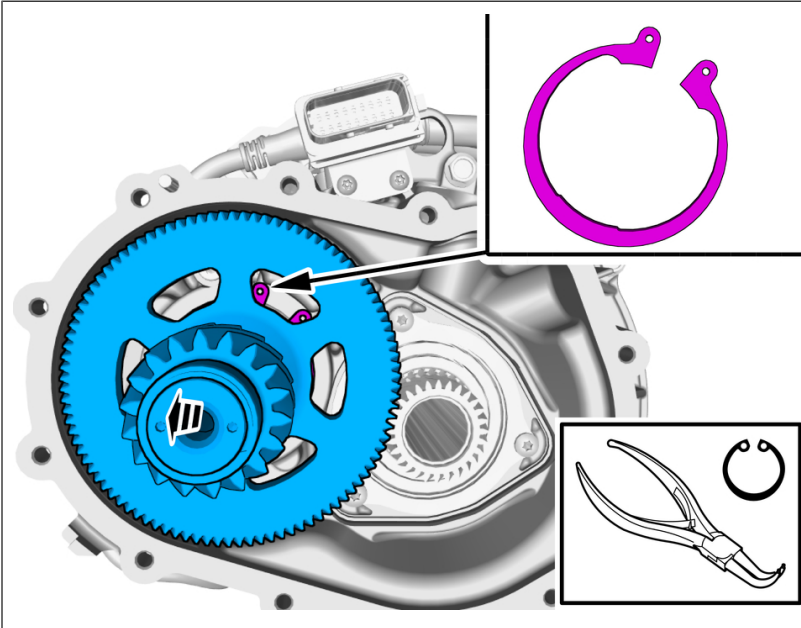

Release the lock.
Remove the marked part.

Use: Circlip pliers

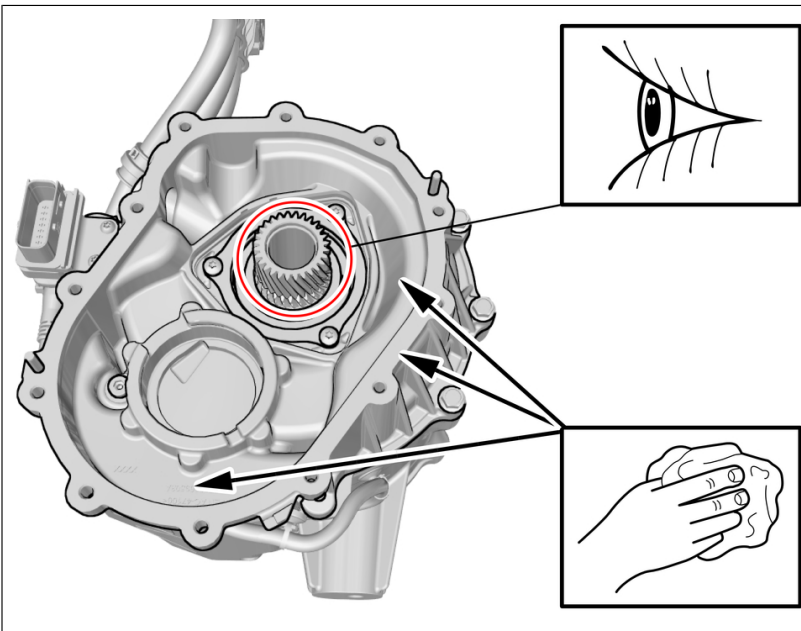

Note! Check the component. if any damage is shown, the whole complete ERAD is to be exchanged.

Note! Make sure that the component is clean and free of foreign material.

Installation

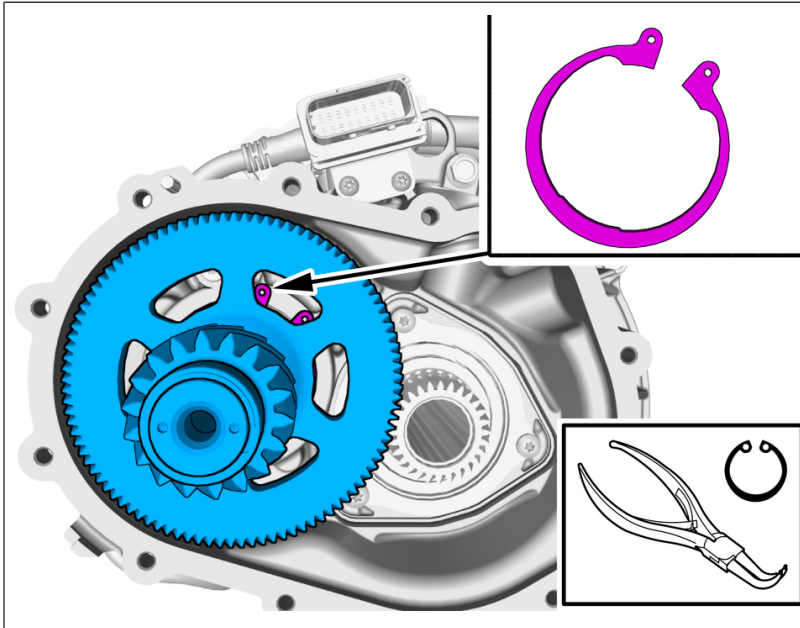

Caution! Make sure that the component is positioned correctly.

Install the catch.

A click confirms that the component is in the correct position.

Use: Circlip pliers

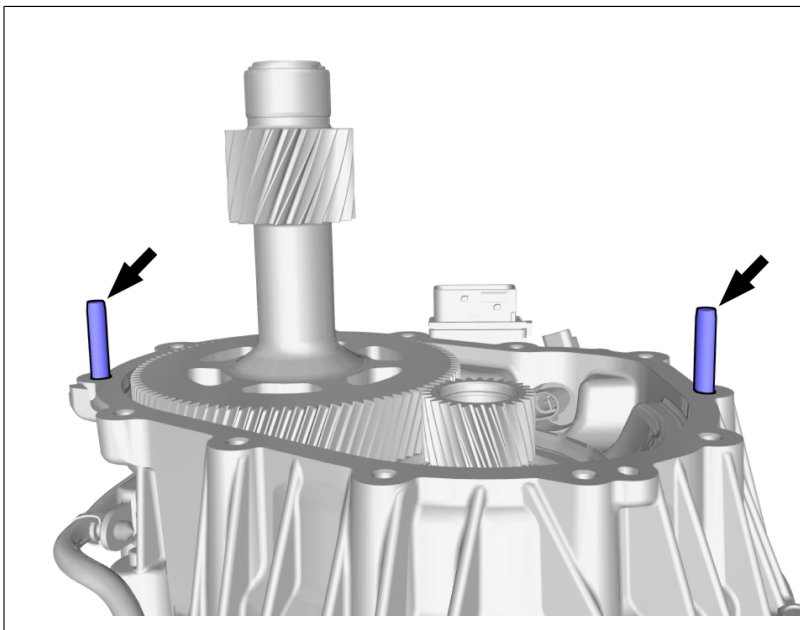

Note! As an alternative if a tool is not at hand, use two bolts M8 x 60 mm with heads cut off.

Note! Use a new seal.

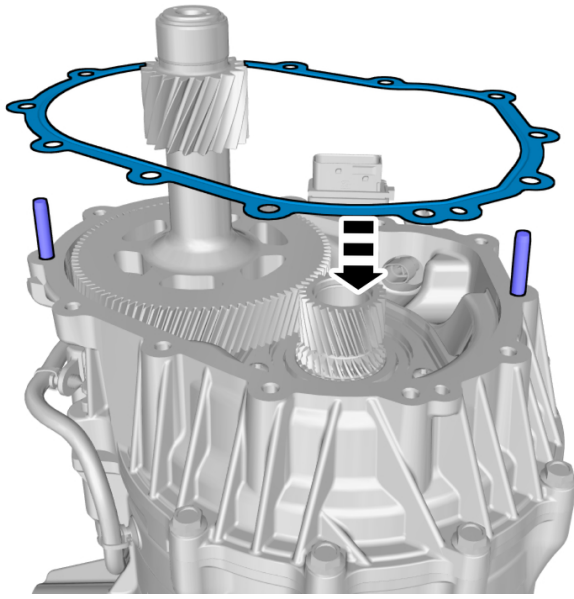

Caution! Make sure that the component is correctly located on the locating dowels.

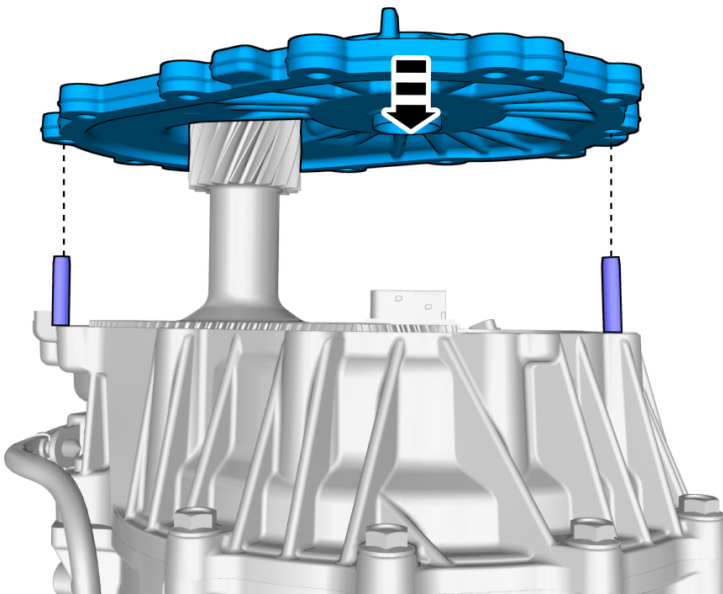

Use: Strip clamp , 983750

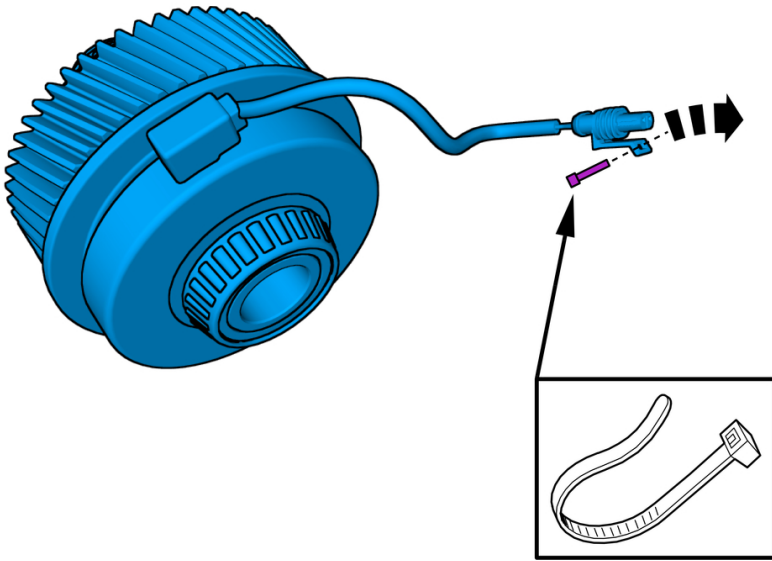

Caution! Make sure that the wiring harness does not catch.

Pull the wiring through.

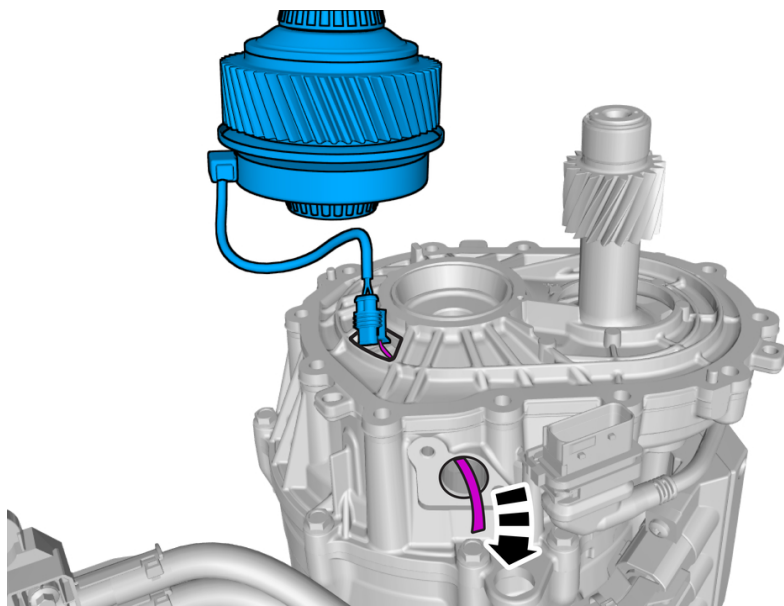

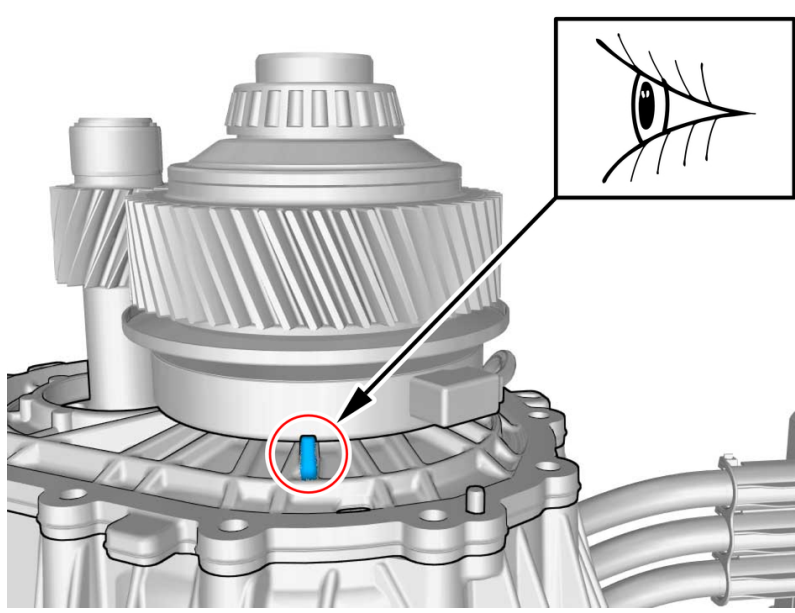

Note! Make sure that the installation marks are aligned.

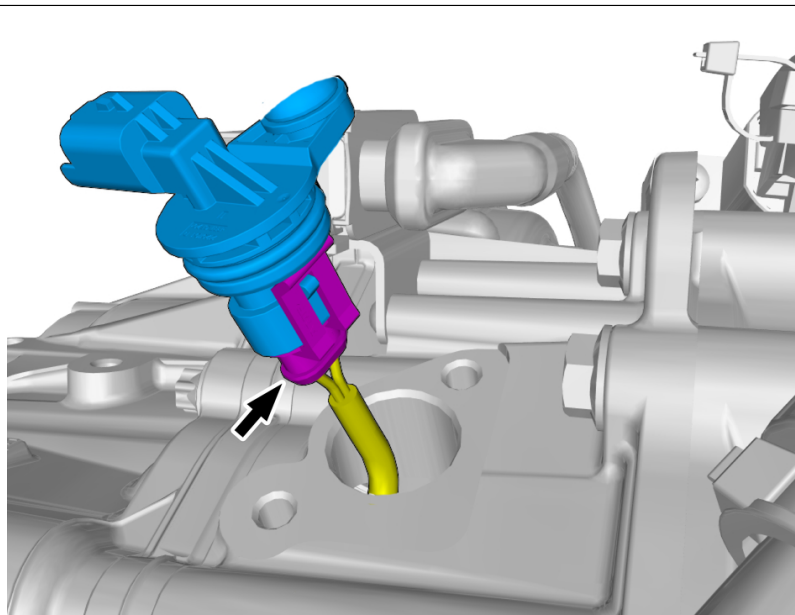

Connect the connector.

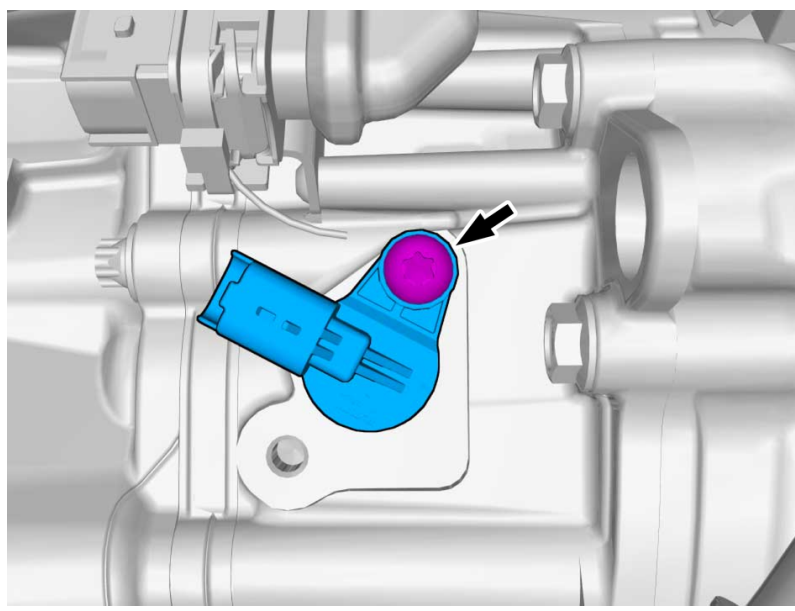

Install the marked component.
Install the screw.

Torque:

Solenoid Connector, to ERAD housing ,
10 Nm

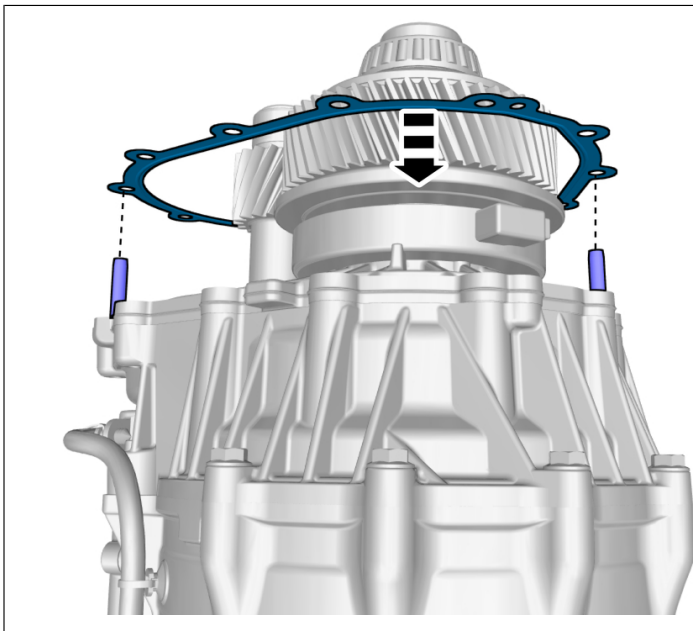

Note! Use a new seal.

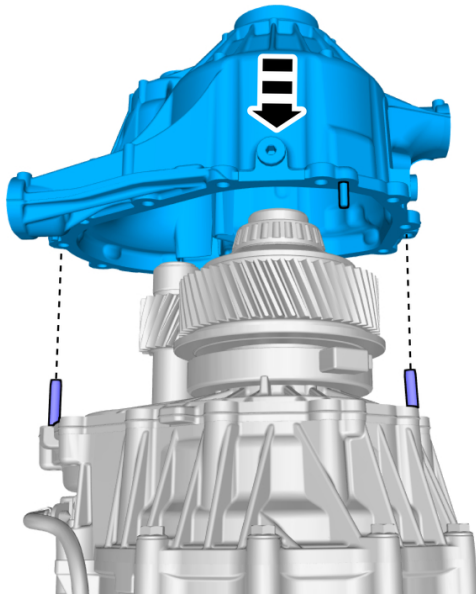

Caution! Make sure that the component is correctly located on the locating dowels.

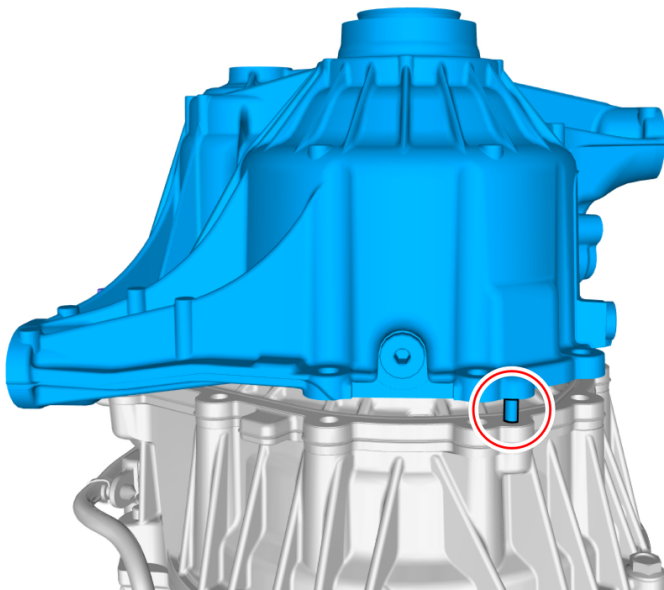

Caution! Make sure that the component is correctly located on the locating dowels.

Remove the Special Tool.

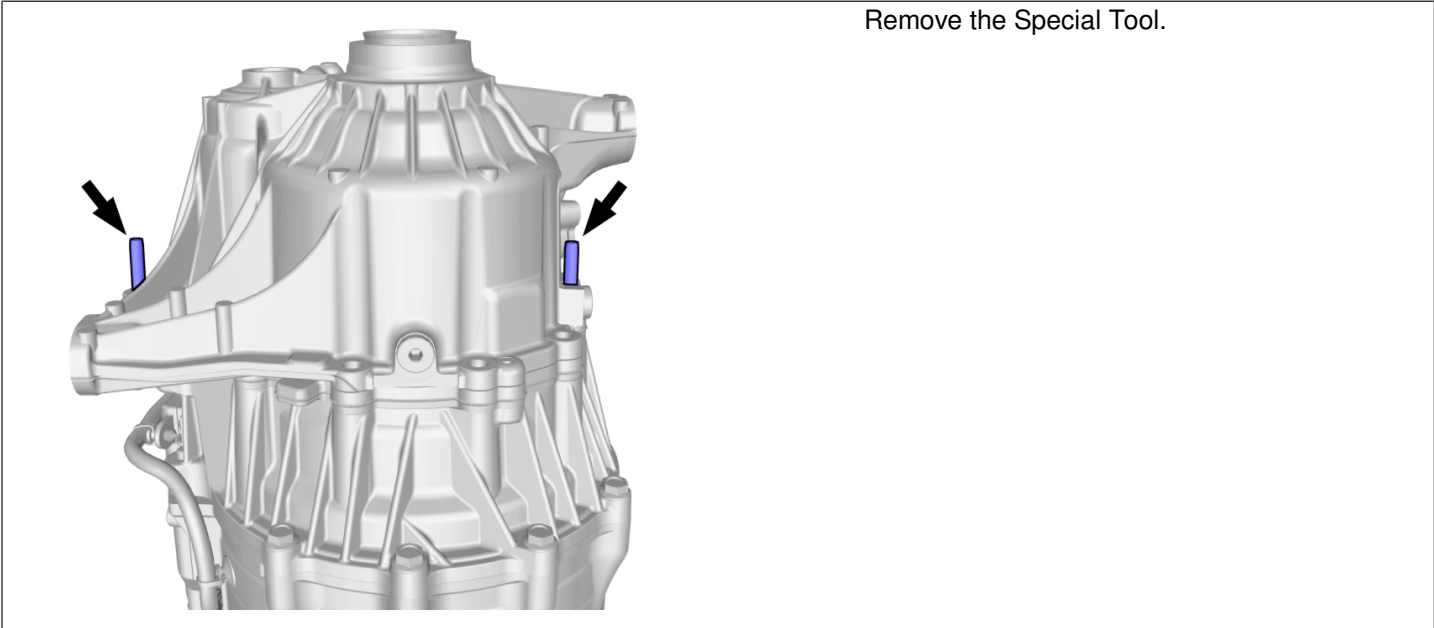

Install the screws.
Tighten the bolts.

Torque:
M8 , 24 Nm

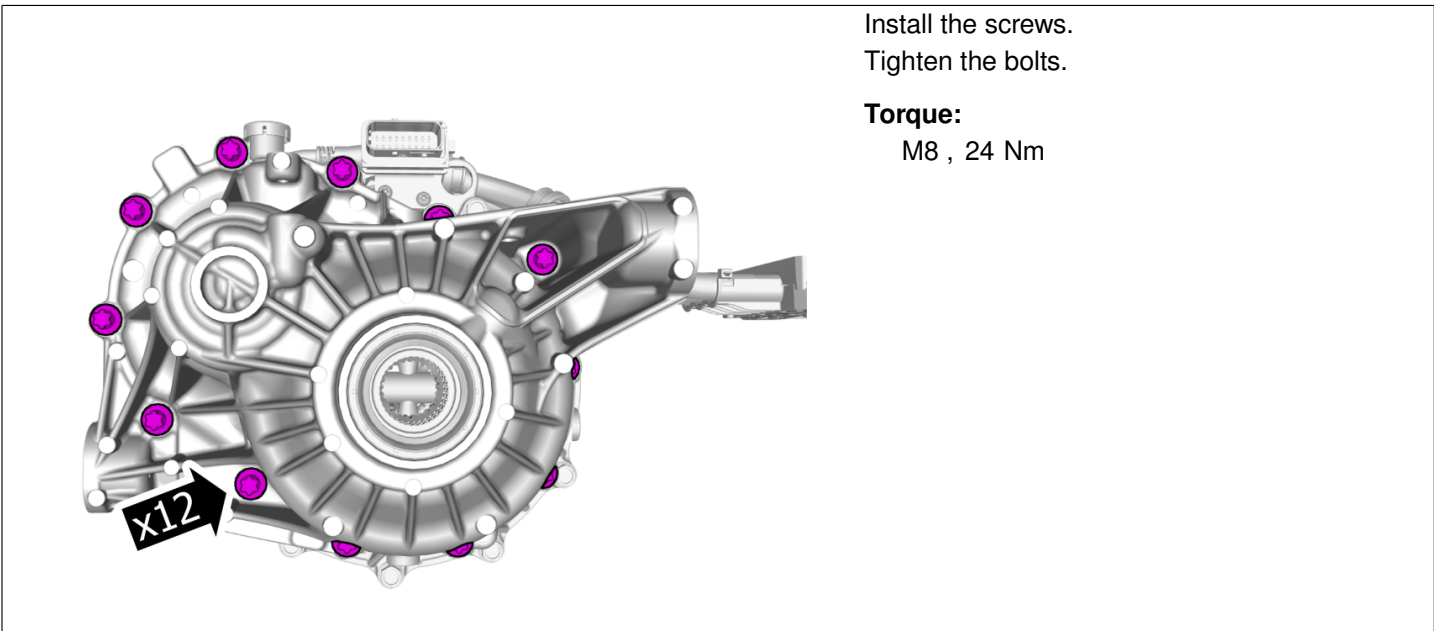

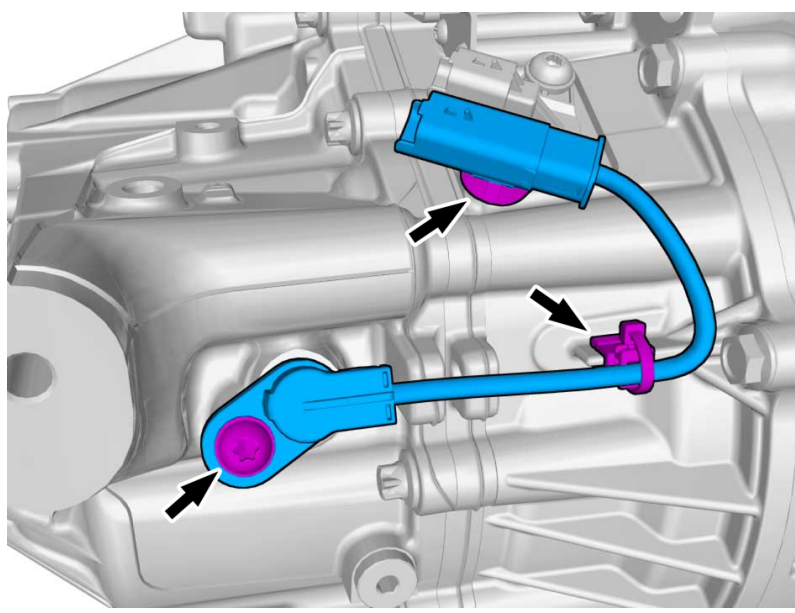

Install the marked component.

Install the screw.

Fasten the wiring harness using the existing clips.

Torque:

Position Sensor Connector, to ERAD housing , 10 Nm

Install electric rear axle drive ERAD , refer to:

Removal, replacement and installation

4 - Power transmission

46 - Rear axle, drive shafts

465 - final drive (front and rear)

Perform ERAD oil level check , refer to:

Cleaning, Inspection and Adjustment

4 - Power transmission

46 - Rear axle, drive shafts

465 - final drive (front and rear)