



# Technical Journal

TITLE:  
**DIM message "Parking brake service required"**

<b>REF NO:</b> TJ 32525.4.0	<b>ISSUING DEPARTMENT:</b> Technical Service	<b>CAR MARKET:</b> United States and Canada	
<b>PARTNER:</b> 3 US 7510 Volvo Car USA		<b>ISSUE DATE:</b> 2018-01-29	<b>STATUS DATE:</b> 2018-02-14
<b>FUNC GROUP:</b> 3710	<b>FUNC DESC:</b> Cables	Page 1 of 25	

"Right first time in Time"

## Attachment

File Name	File Size
TJ32525.JPG	0.1931 MB
TJI-503688-2_1_2_en-US.pdf	3.5583 MB
TJI-503692-2_1_1_en-US.pdf	3.8535 MB

## Vehicle Type

Type	Eng	Eng Desc	Sales	Body	Gear	Steer	Model Year	Plant	Chassis range	Struc Week Range
234							2017-9999		-	201617-999952
235							2017-9999		-	201624-999952

## CSC Customer Symptom Codes

Code	Description
PK	Parking brake/No/reduced/incorrect function

## VST Operation Number

VST Operation Number	Description
98663-2	Cutting of cable harness acc. to TJ



## DTC Diagnostic Trouble Codes

Control Module	Code	Fault Type
BCM	C20081B	Permanent
BCM	C200713	Permanent
BCM	C200E29	Permanent
BCM	C200574	Permanent
BCM	C20071B	Permanent
BCM	B111177	Permanent

Rows beginning with \* are modified

Note! If using a printed copy of this Technical Journal, first check for the latest online version.

### Text

#### DESCRIPTION:

If the DIM message “Parking Brake Service required” appears in the DIM and applicable DTC’s are present, please follow instructions under “Service”.

\*Changes in this version:

- DTC added, BCM-C20081B.
- Repair instructions with new part number.
- Spare parts are now available through normal channels i.e. parts department.

DIM = Driver Information Module

BCM = Brake Control Module

#### SERVICE:

\*NOTE: The DTC’s may have been set due to other reasons than damaged wiring.

\*Please study typical examples of damaged areas in the attachment “TJ32525.jpg” before replacing any harness.

Check wire harness for the emergency parking brake on the rear control arm(s), if wires are damaged.

Perform repair as per attached instructions.

TJI 503688 - right hand side

TJI 503692 - Left hand side

#### VEHICLE REPORT:

Yes, please submit a Vehicle Report if the service solution described in this TJ has no effect. Use concern area “Vehicle Report” and sub concern area “Support not needed”, use function group 3760.

**To view TJ attachments continue to next page. This TJ has three attachments.**





## Volvo Car Customer Service

TJ Instruction VCC-503688-2

<b>Title</b>	Joining wires, right	<b>Page</b>	1 ( 11 )
<b>Action</b>	Product fix	<b>Operation number:</b>	98663-2

Issue	Date	Reason
2	2018-01	Materials list change
1	2017-05	First issue

### Affected vehicles

Model year	Model
2017	S90 (17-)
2017, 2018	V90 (17-)

### Materials

Materials	Qty.	Part No.	Notes
Electrical tape	0.1	9511028	Consumable;
Tape	0.1	1985615	WURTH Part Number; Consumable;
Kit	1.0	32214495	

### Equipment

Designation	Part No.
Angle drill machine	

Removal

Note! Removal steps in this procedure may contain installation details.

Orientation view

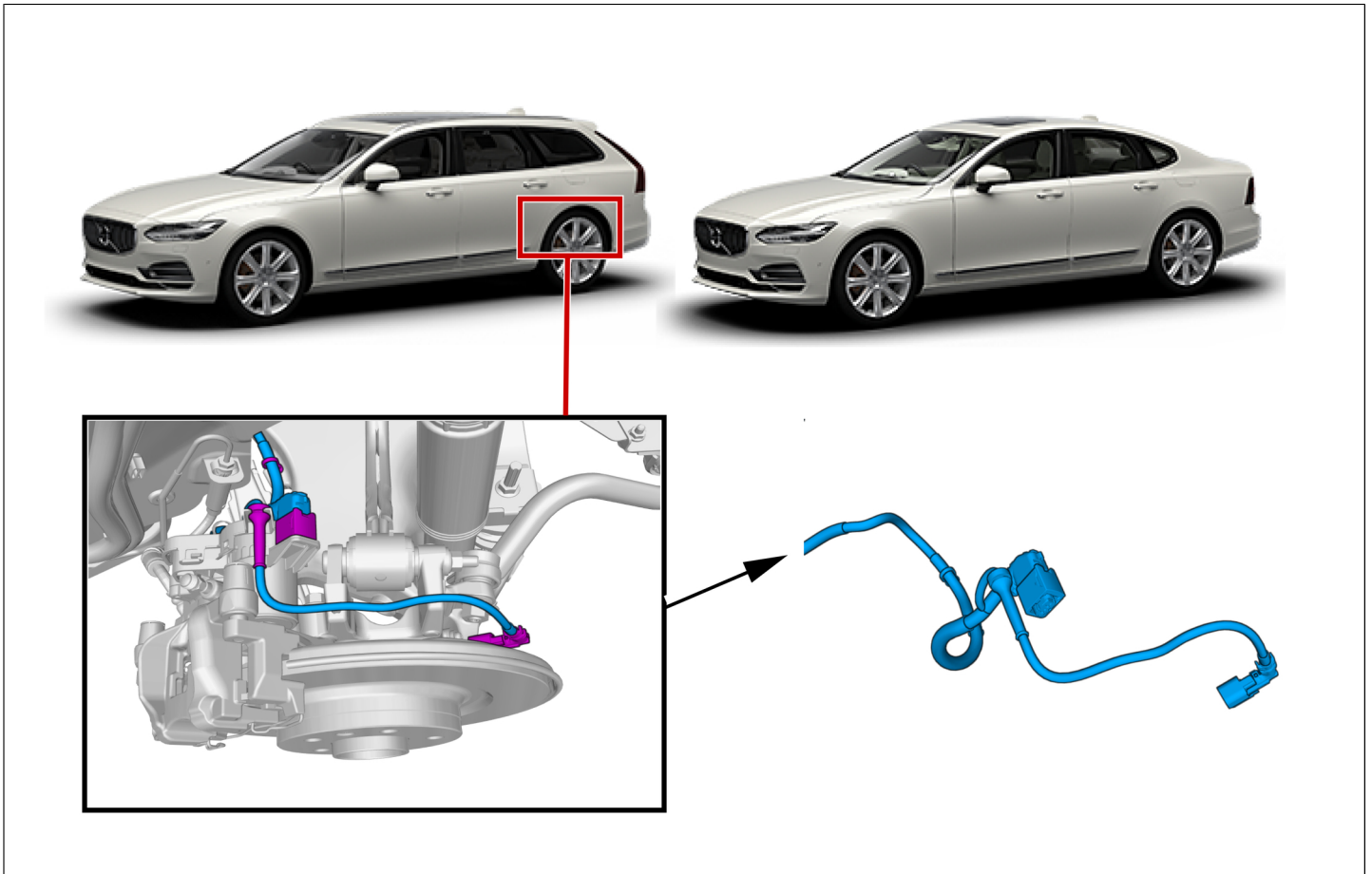

## Color symbols

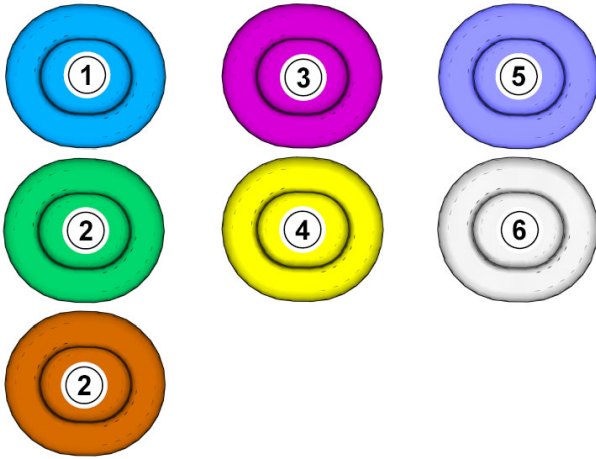

**Note! This colour chart displays (in colour print and electronic version) the importance of the different colours used in the images of the method steps.**

- 1 . Used for focused component, the component with which you will do something.
- 2 . Used as extra colors when you need to show or differentiate additional parts.
- 3 . Used for attachments that are to be removed/installed. May be screws, clips, connectors, etc.
- 4 . Used when the component is not fully removed from the vehicle but only hung to the side.
- 5 . Used for standard tools and special tools.
- 6 . Used as background color for vehicle components.

Set the vehicle to Inactive mode, described in user mode , refer to:

- General Information
- 3 - Electrical system
- 30 - General
- 300 - general

Remove the right rear wheel , refer to:

- Removal, replacement and installation
- 7 - Springs and wheels
- 77 - Wheels, tyres, hubs
- 771 - wheel and wheel trim

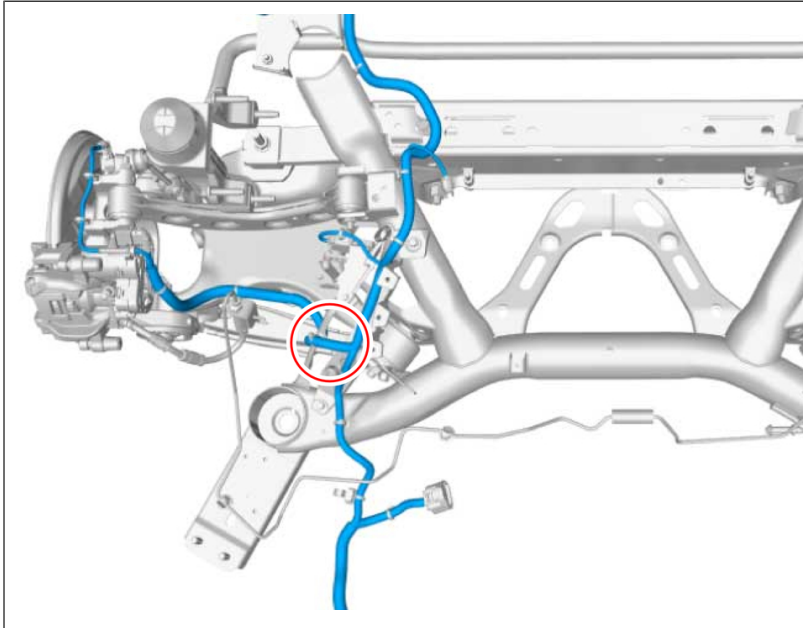

Note! Orientation view

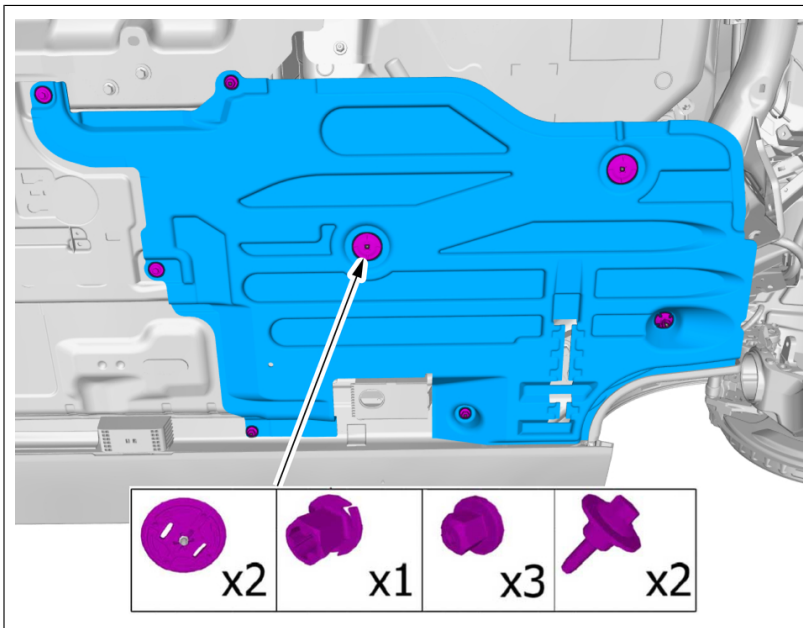

Remove the screws.  
Remove the clips.  
Remove the marked part.

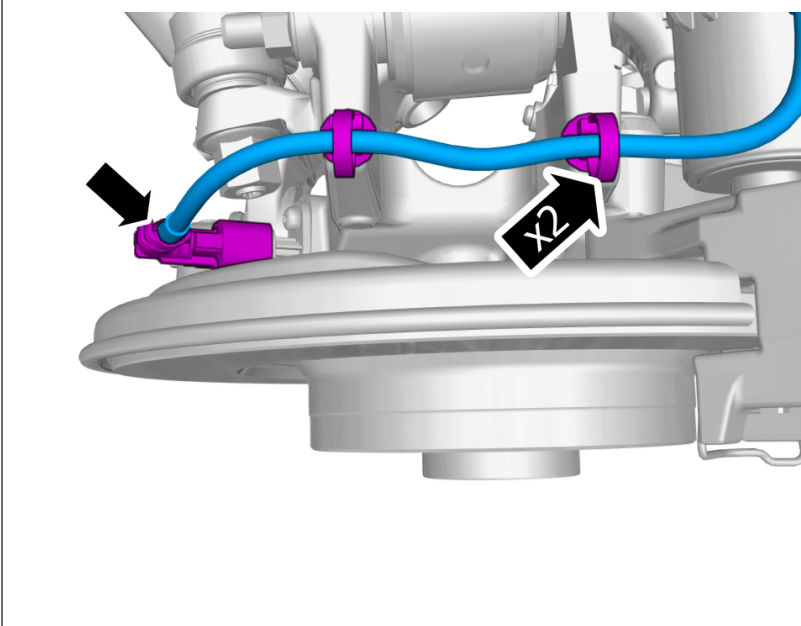

Loosen the clips.  
Disconnect the connector.

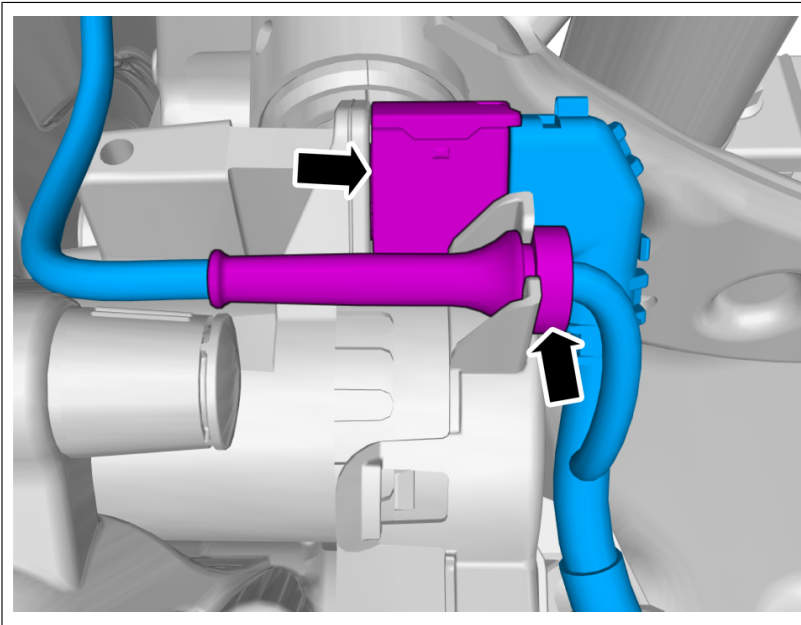

Disconnect the connector.  
Loosen the fastener.



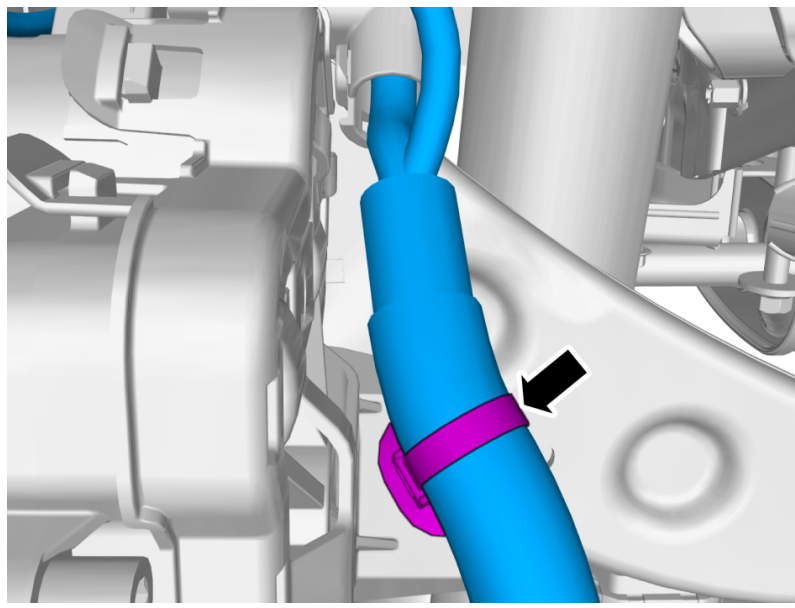

Loosen the clip.

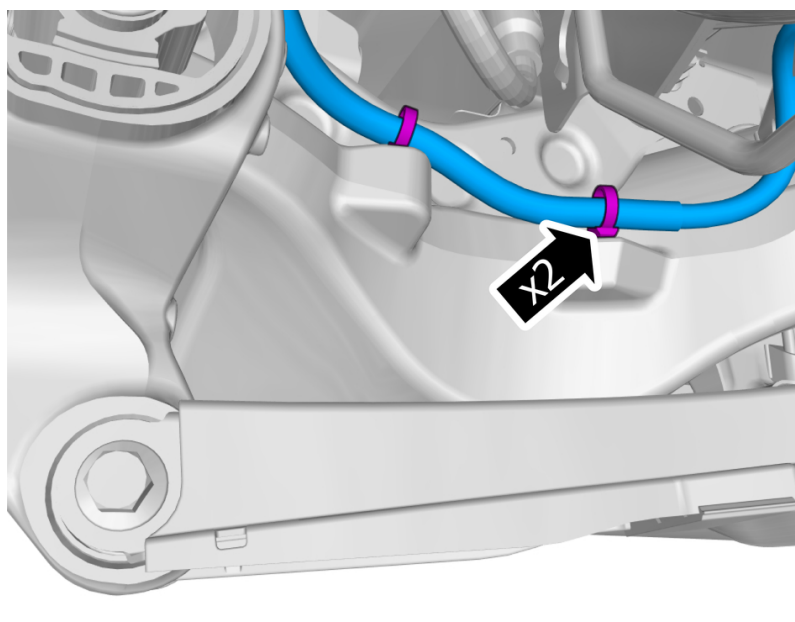

Loosen the clips.

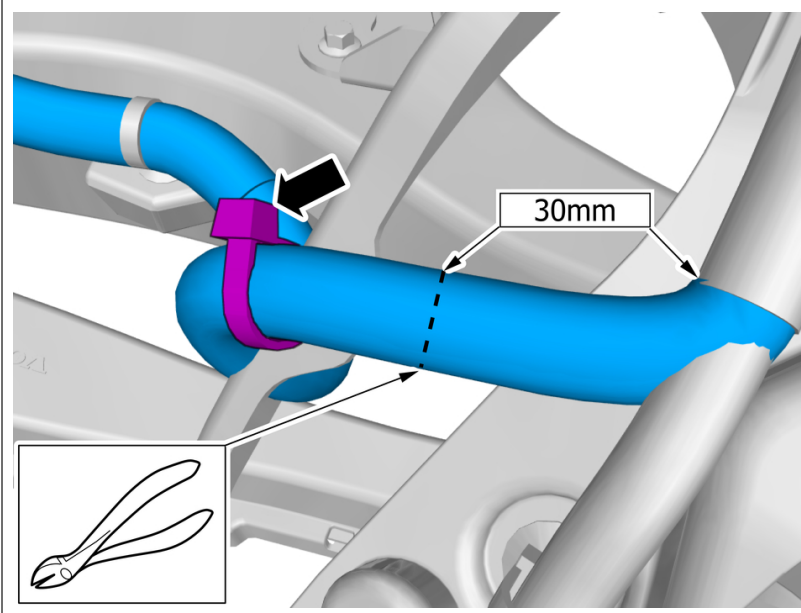

Loosen the clip.  
Cut

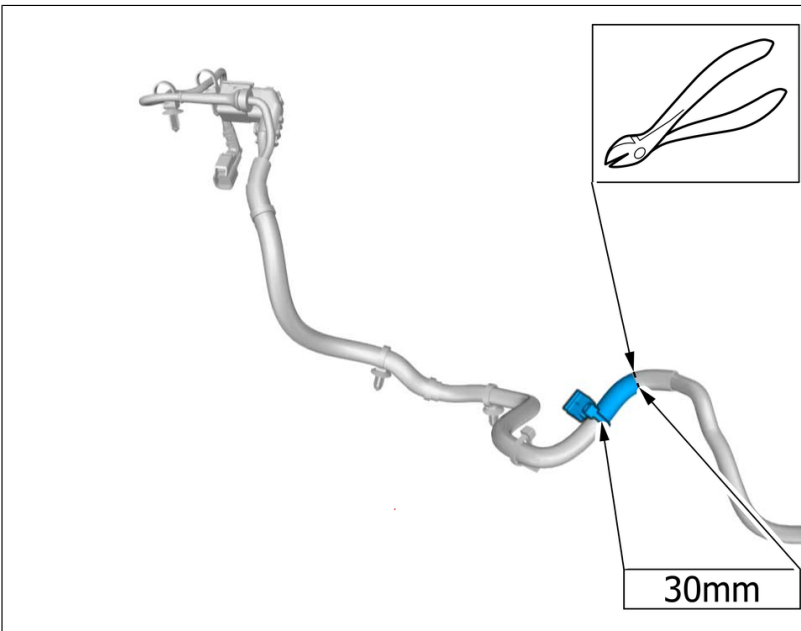

This step is performed on new component.

### Installation

Carry out splicing of wire , refer to:  
Cleaning, Inspection and Adjustment  
3 - Electrical system  
37 - Cables and fuses  
371 - cables

- 1 · **Use:** Electrical tape , 9511028
- 2 · **Use:** Tape , 9511071

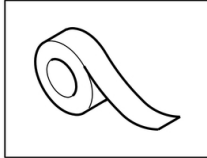
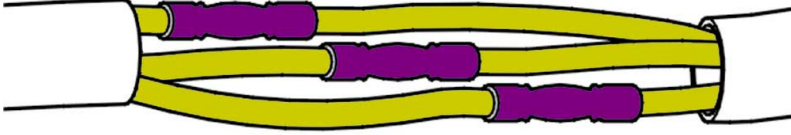

Position wire as illustrated.  
Install the clip(s).

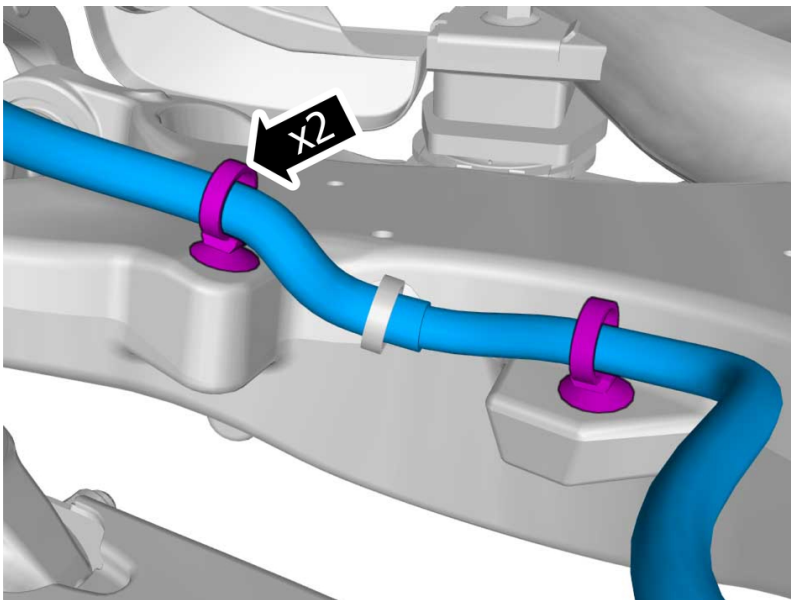

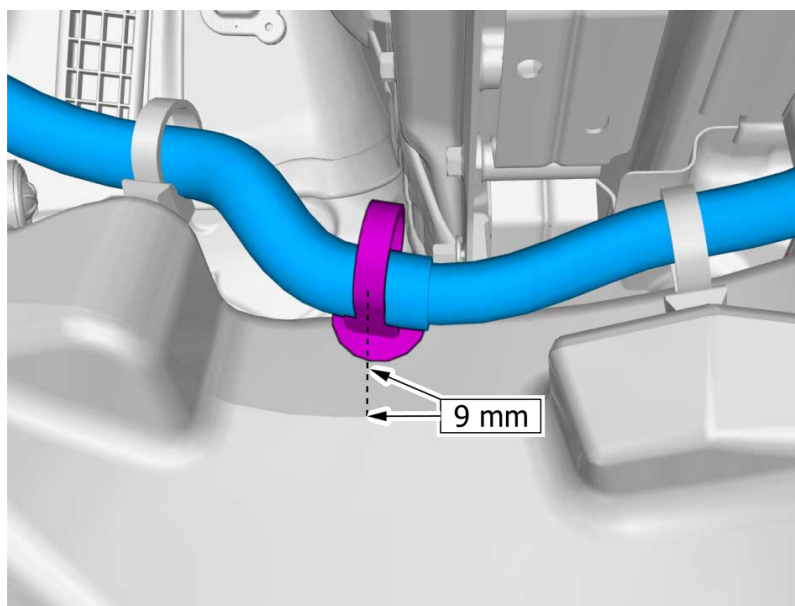

Measure from upper flange edge.  
Mark using a pen

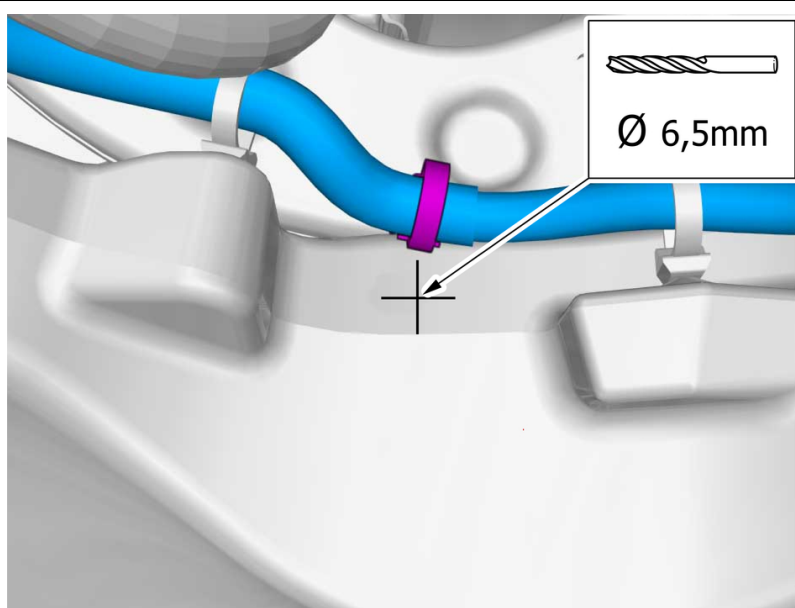

Position wire as illustrated.  
**Use:** Angle drill machine

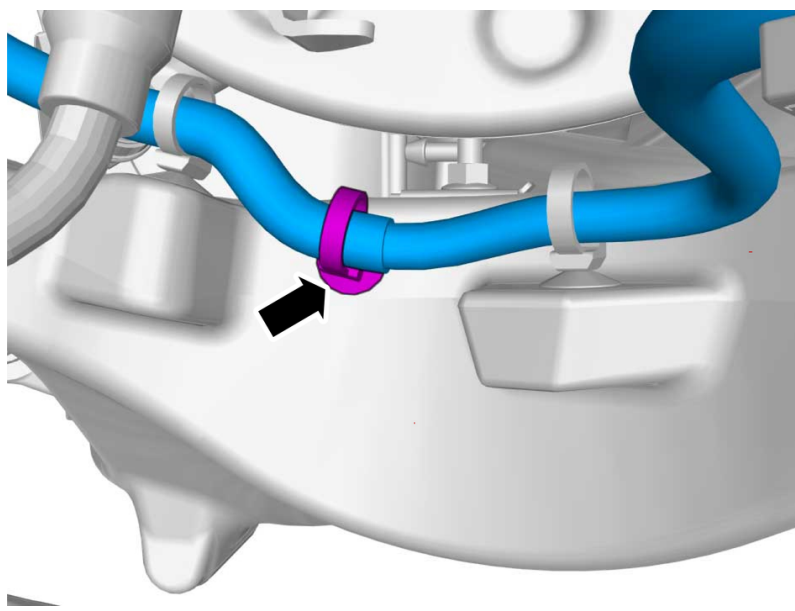

Install the clip(s).

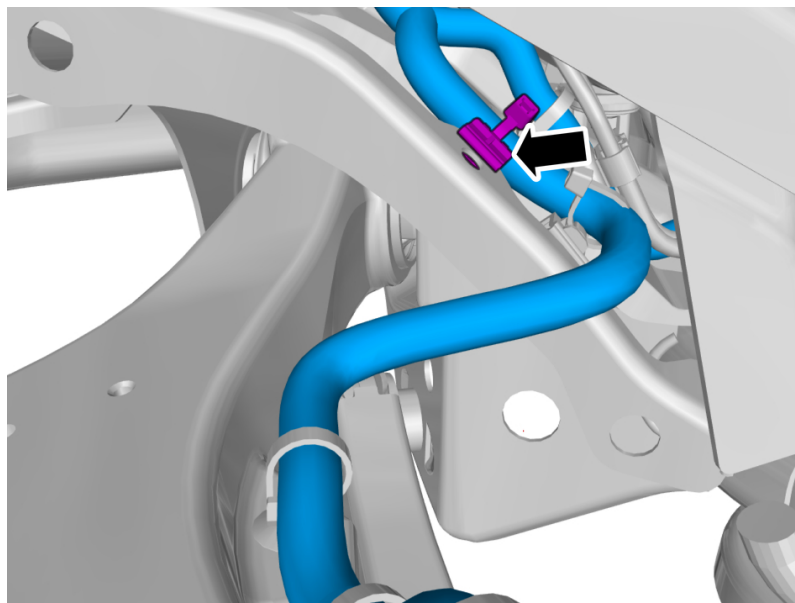

Position wire as illustrated.  
Install the clip(s).

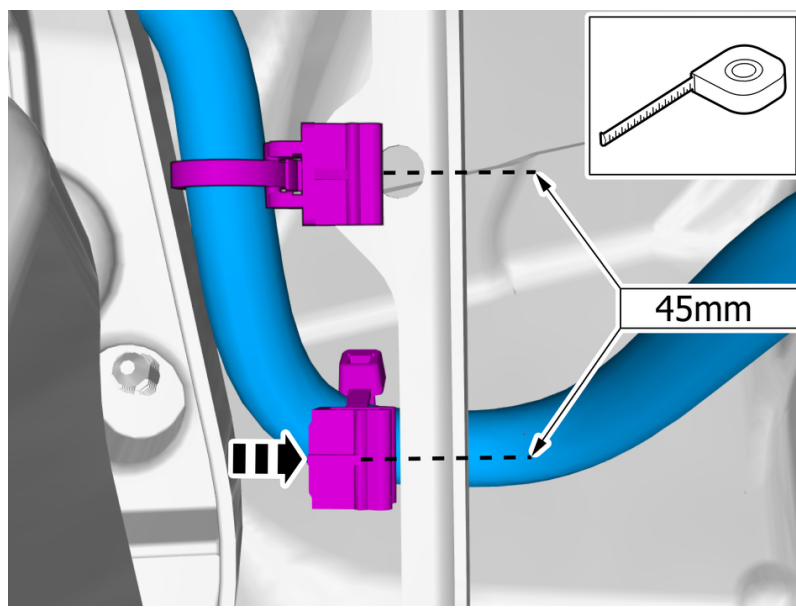

View from below  
Mark using a pen  
Install the clip(s).

To install, reverse the removal procedure.



## Volvo Car Customer Service

TJ Instruction VCC-503692-2

<b>Title</b>	Joining wires, left	<b>Page</b>	1 ( 11 )
<b>Action</b>	Product fix	<b>Operation number:</b>	98663-2

Issue	Date	Reason
1	2017-05	First issue
2	2018-01	Materials list change

### Affected vehicles

Model year	Model
2017	S90 (17-)
2017, 2018	V90 (17-)

### Materials

Materials	Qty.	Part No.	Notes
Strip clamp	1.0	983671	
Electrical tape	0.1	9511028	Consumable;
Tape	0.1	1985615	WURTH Part Number; Consumable;
Kit	1.0	32214494	

### Equipment

Designation	Part No.
Angle drill machine	

Removal

Note! Removal steps in this procedure may contain installation details.

Orientation view

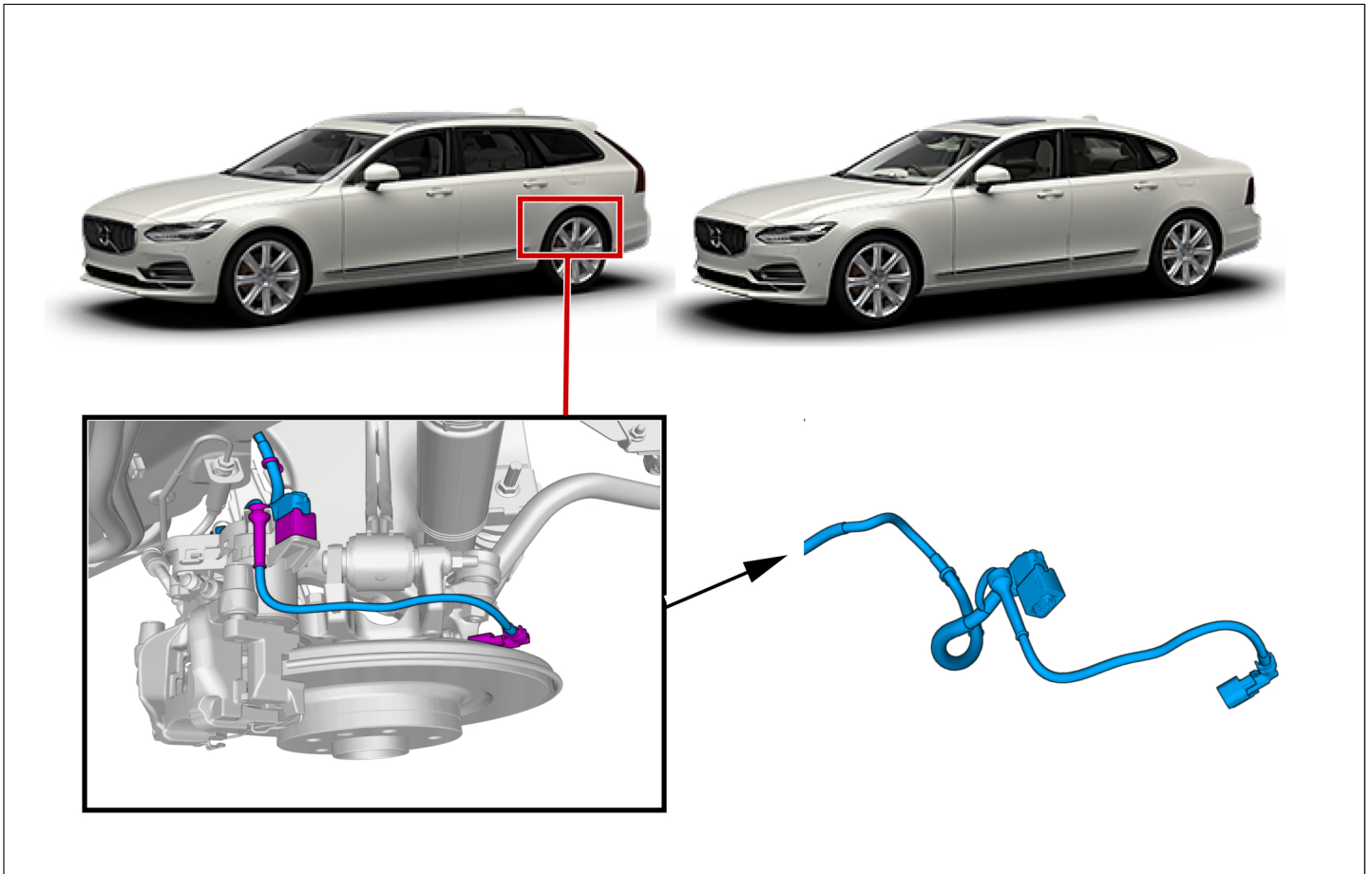



## Color symbols

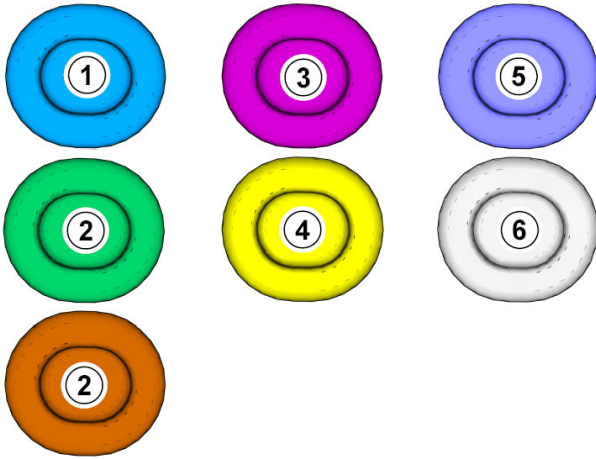

**Note! This colour chart displays (in colour print and electronic version) the importance of the different colours used in the images of the method steps.**

- 1 . Used for focused component, the component with which you will do something.
- 2 . Used as extra colors when you need to show or differentiate additional parts.
- 3 . Used for attachments that are to be removed/installed. May be screws, clips, connectors, etc.
- 4 . Used when the component is not fully removed from the vehicle but only hung to the side.
- 5 . Used for standard tools and special tools.
- 6 . Used as background color for vehicle components.

Set the vehicle to Inactive mode, described in user mode , refer to:

- General Information
- 3 - Electrical system
- 30 - General
- 300 - general

Remove the left rear wheel , refer to:

- Removal, replacement and installation
- 7 - Springs and wheels
- 77 - Wheels, tyres, hubs
- 771 - wheel and wheel trim

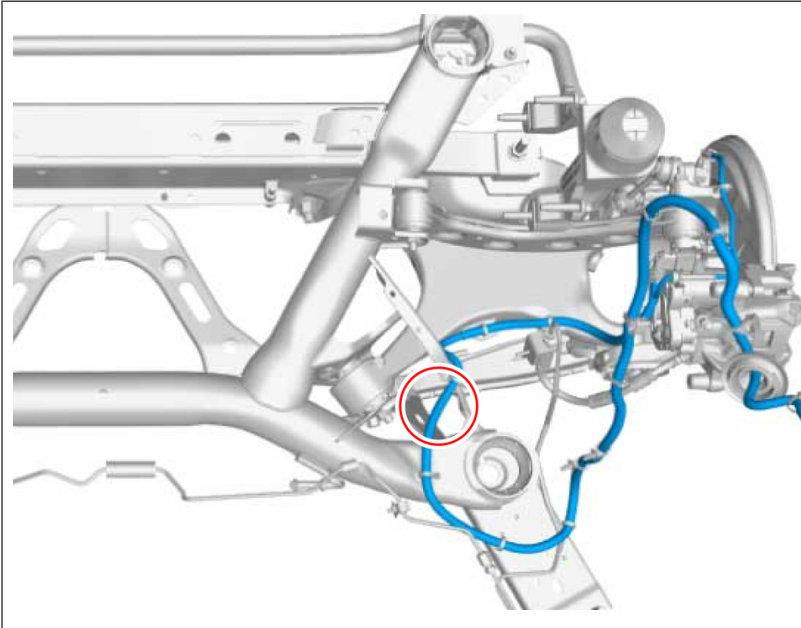

Note! Orientation view

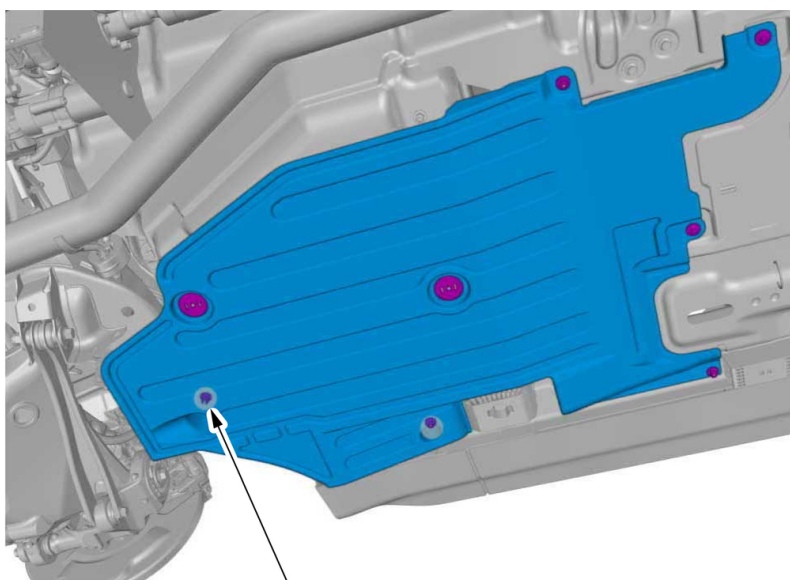

Remove the screws.  
Remove the clips.  
Remove the marked part.

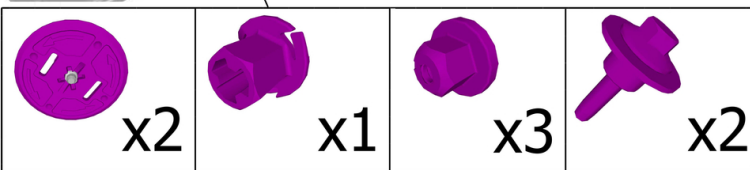

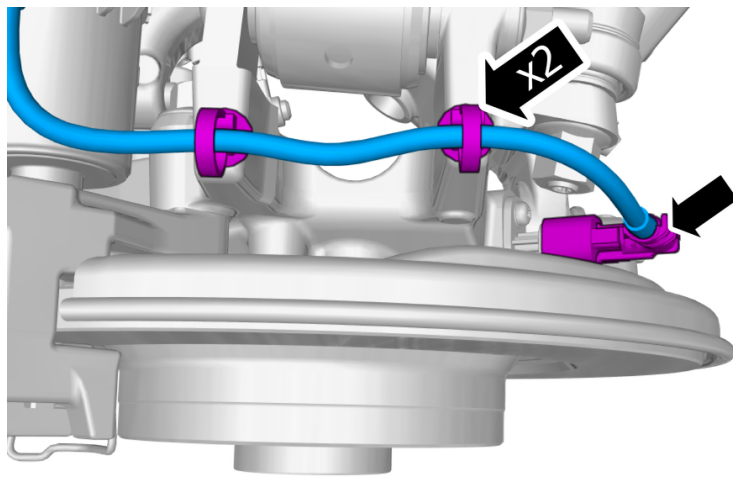

Loosen the clips.  
Disconnect the connector.

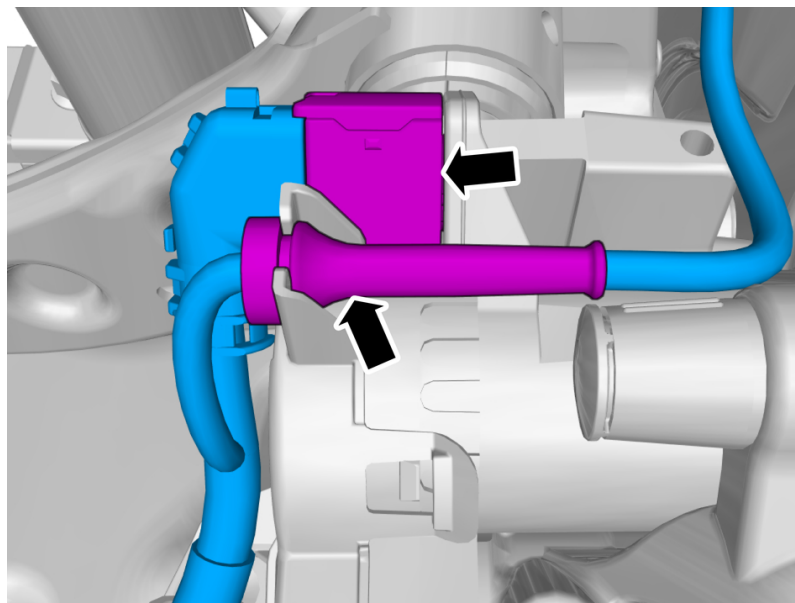

Disconnect the connector.  
Loosen the fastener.

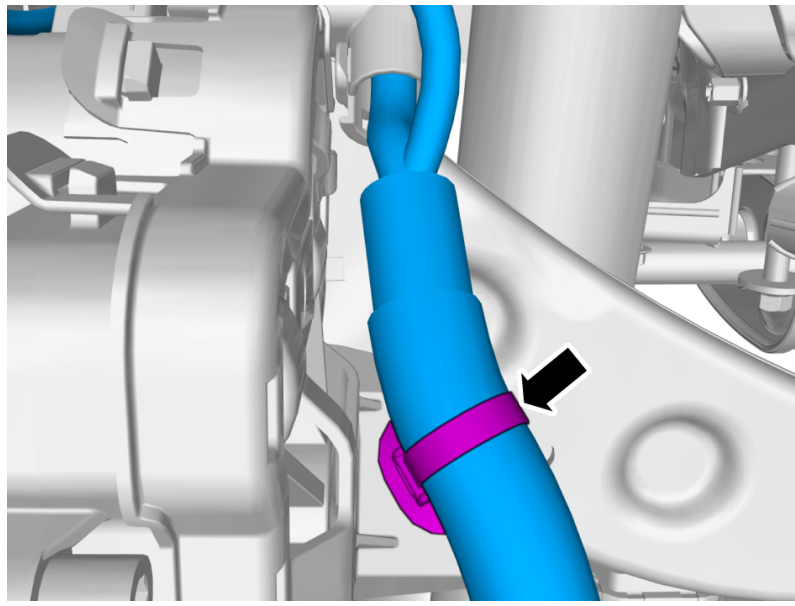

Loosen the clip.

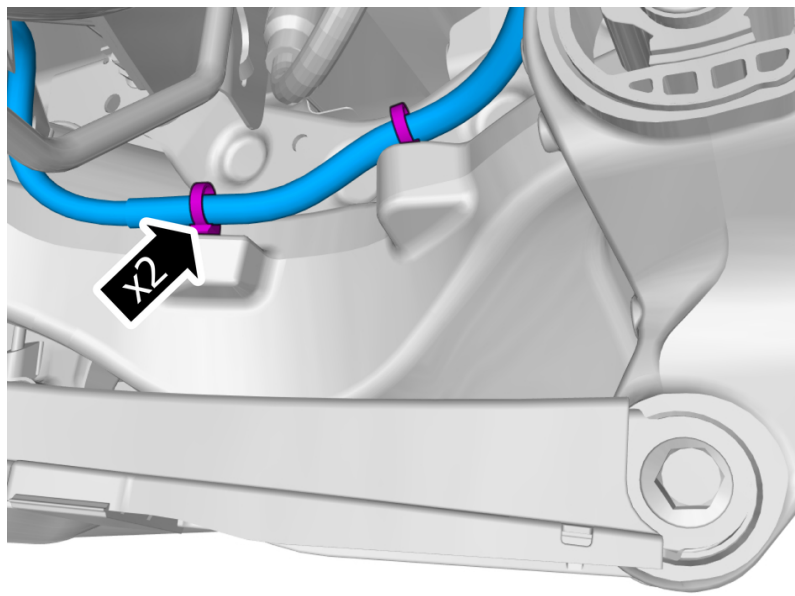

Loosen the clips.

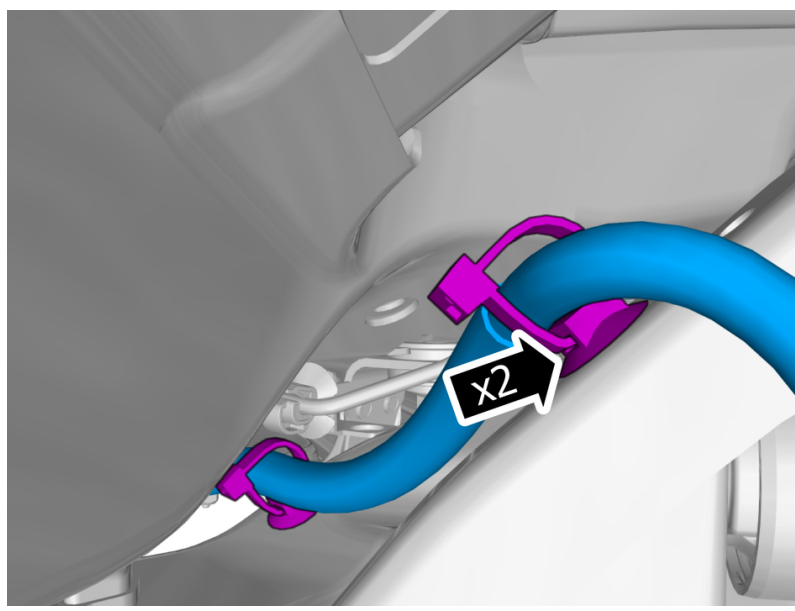

**Note! Make sure that a new component is installed.**

Loosen the clips.

**Use:** Strip clamp , 983671

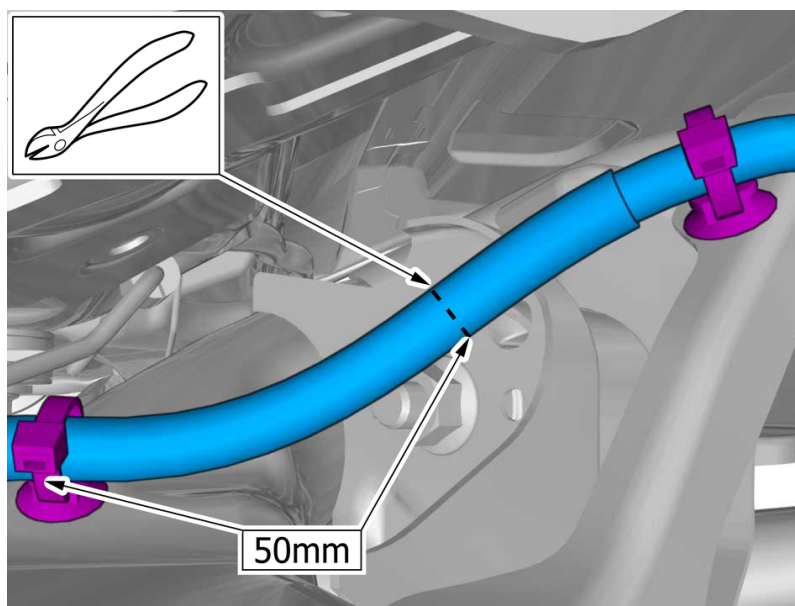

Cut

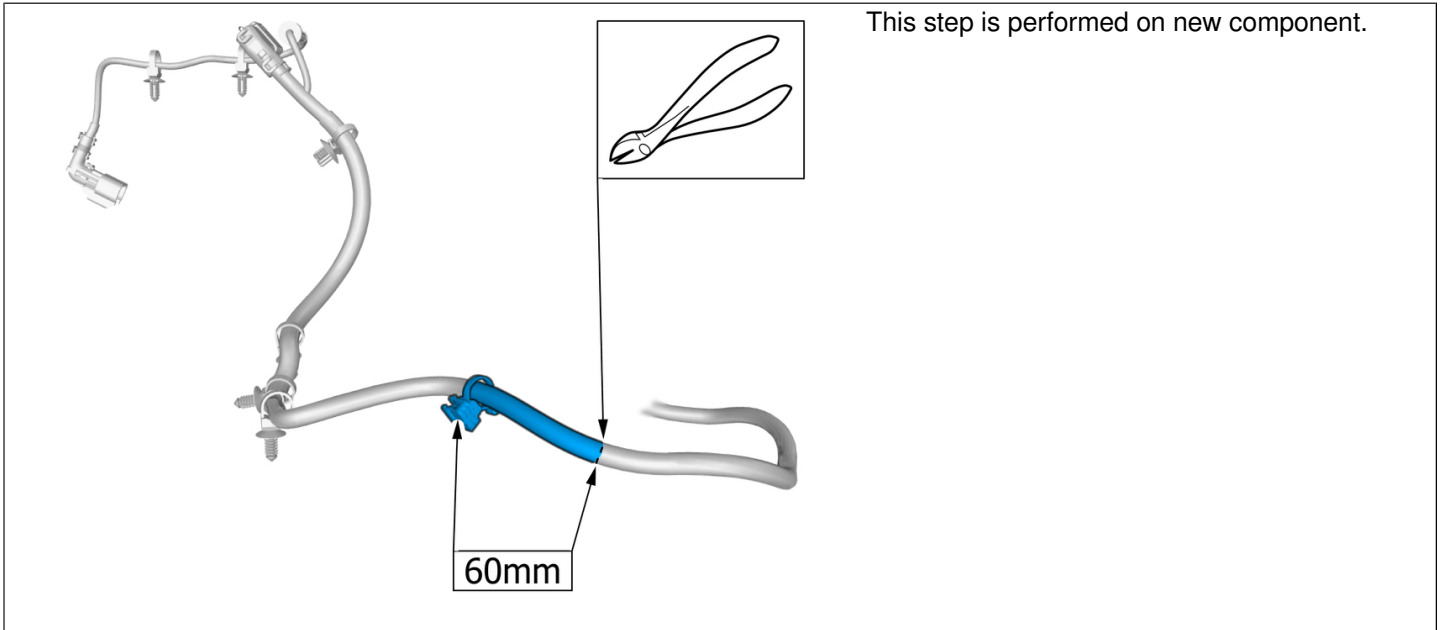

### Installation

Carry out splicing of wire , refer to:  
Cleaning, Inspection and Adjustment  
3 - Electrical system  
37 - Cables and fuses  
371 - cables

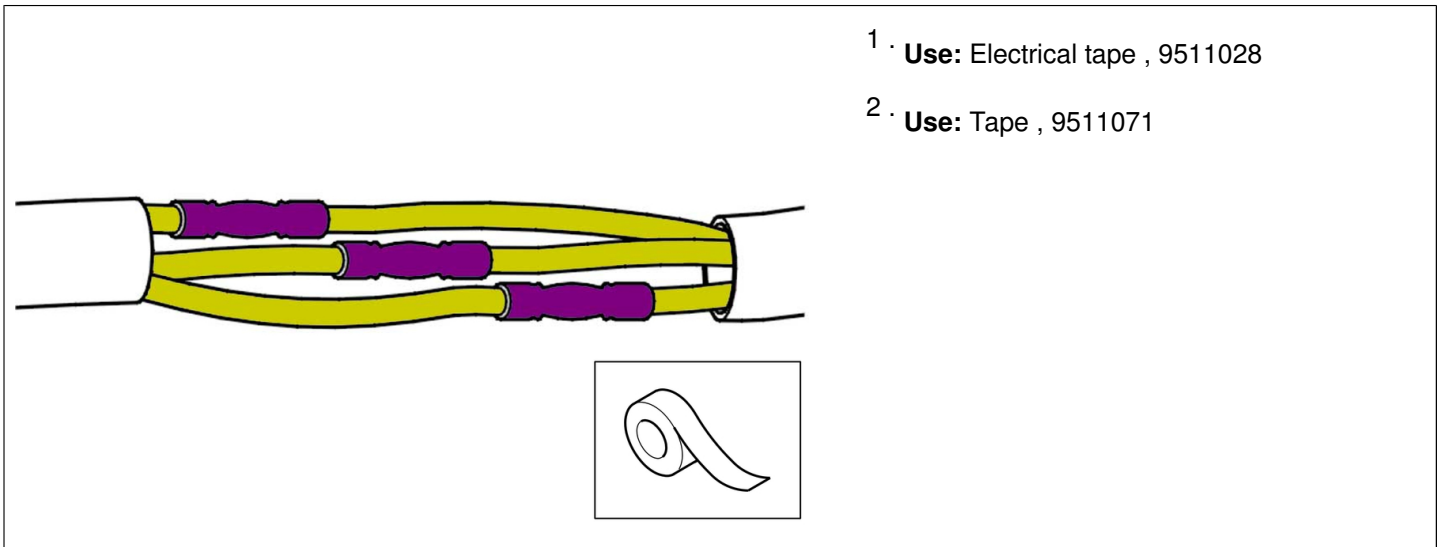

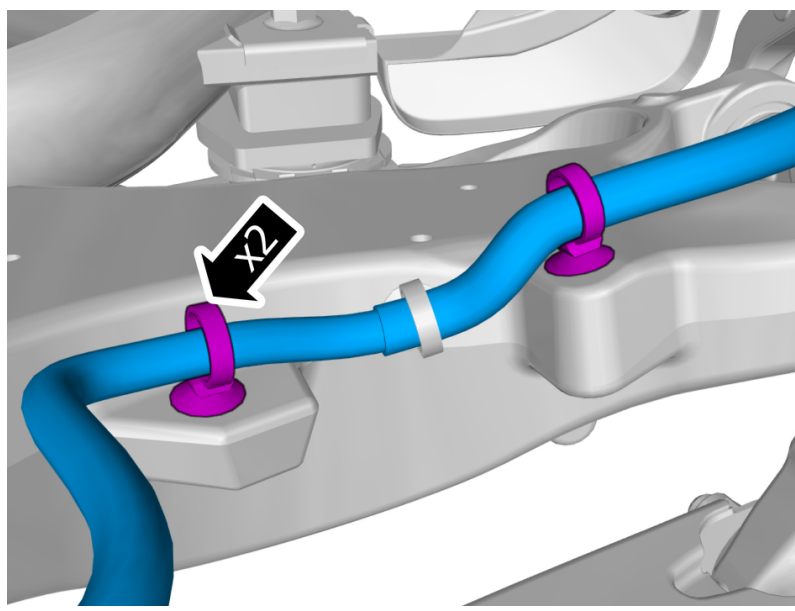

Position wire as illustrated.  
Install the clip(s).

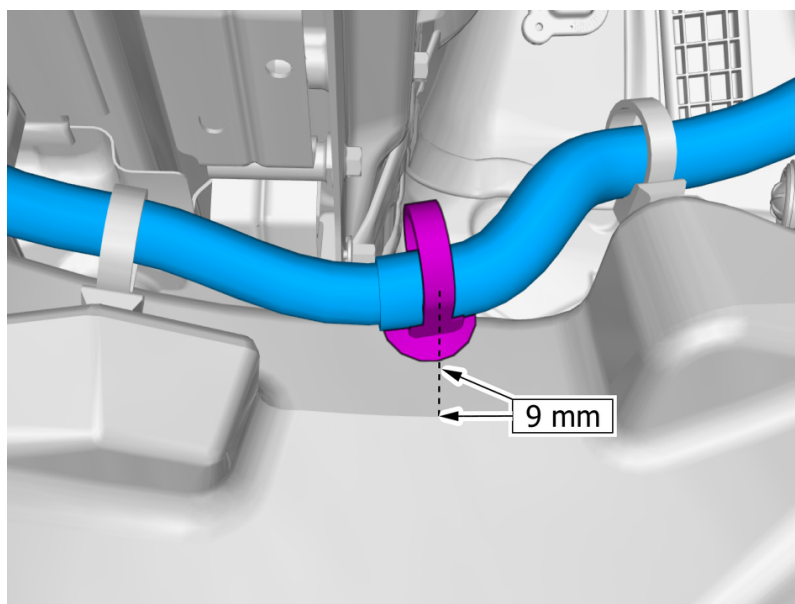

Measure from upper flange edge.  
Mark using a pen

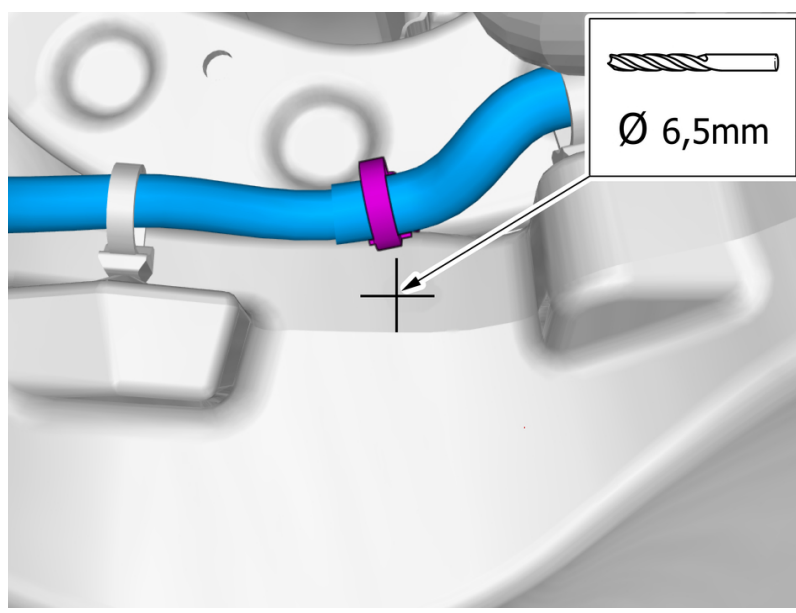

Position wire as illustrated.  
**Use:** Angle drill machine

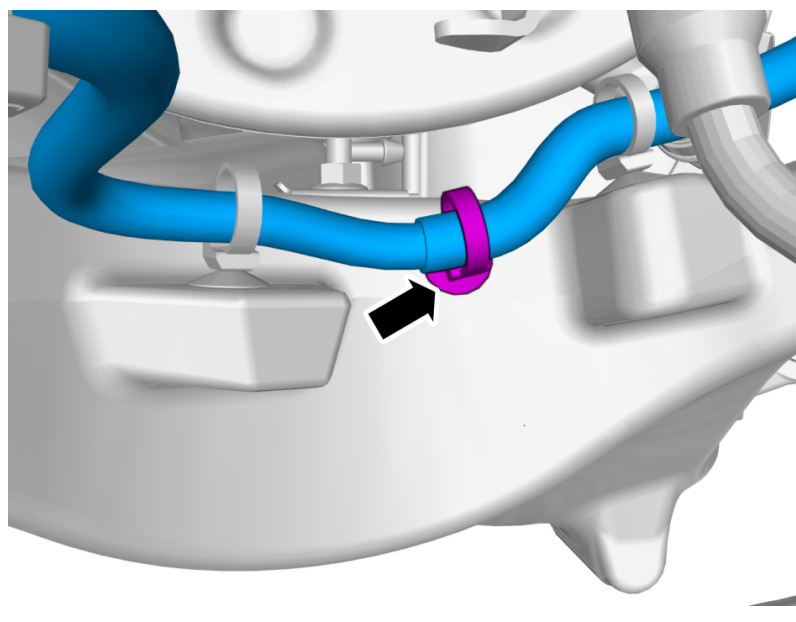

Install the clip(s).



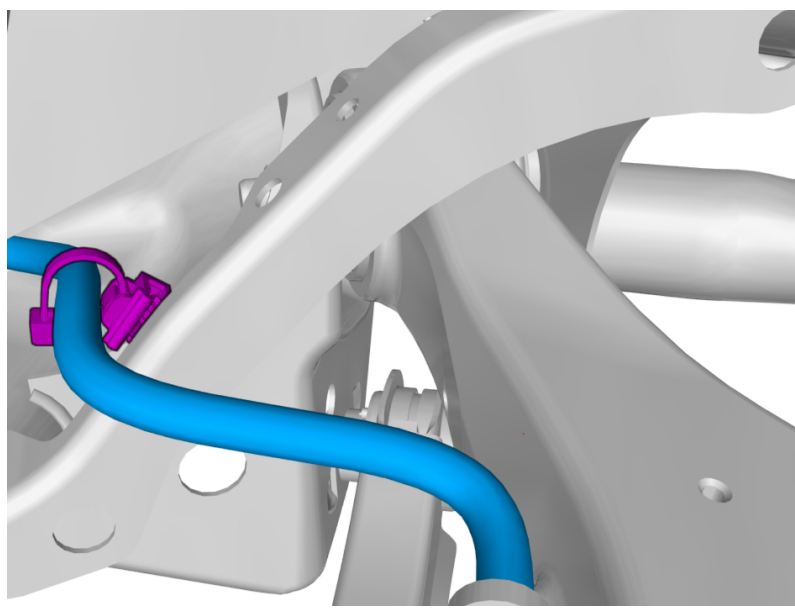

Position wire as illustrated.

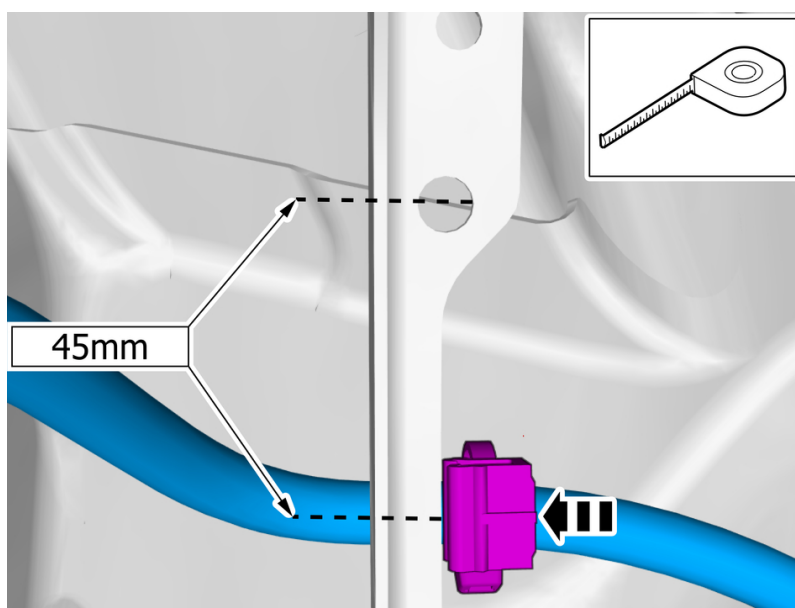

View from below  
Mark using a pen  
Install the clip(s).

To install, reverse the removal procedure.