



Volvo Chassis - Timing Gear Plate Repair

Internal Content

2018 vgt and newer

Information

This solution provides supplementary information to be used when installing a Timing Gear Plate with Integrated Seal.

Repair Criteria

For inspection procedures and repair criteria, refer to TSB [V-212-003 Timing Gear Plate, Inspection](#) in Impact.

Tools

- **For Turbo Compound:** A new Turbo Component Support Tool has been developed. This tool is designed to support the TC unit in place while performing TGP Repair.
 - Tool Part Number 88800826.
 - For additional information, see Tool Bulletin [STB23-005V](#) and the [Trucks Academy Video](#).
- A list of other tools required can be found on the Job Aid included at the end of this solution.

Parts

- **PART KITS** have been developed to include all necessary parts for a complete repair. New Seal Conditioner will be included in all kits (instructions for seal condition application below):
 - **VGT Engines:** Spare Parts Kit 24459407
 - **Turbo Compound Engines:** Spare Parts Kit 24459389



Repair

The timing gear plate replacement procedure in Impact should be utilized for this repair **in addition to the supplementary installation steps for application of the seal conditioner below.**

- The Impact procedure is Operation [2152-03-03-05 Timing Gear Plate, Replacement - Transmission and Clutch Removed](#).
- **IMPORTANT:** Loosening of the rocker shaft and overhead adjustment **IS NOT REQUIRED** when following the Impact instructions. There are new steps included in the Impact procedure for setting gear backlash.

Seal Conditioner Application

1. Clean engine block TGP seal mating surface of any oil, grease, dirt. Inspect and clean the TGP bolt holes in rear of the engine block.
2. Apply a **LIGHT FILM** of the seal conditioner (included in the part kit) with a gloved finger to the TGP mating seal surface of the block.
 - Avoid getting conditioner in bolt holes.
 - Remove any excess seal conditioner from bolt holes.
 - **IMPORTANT:** To keep conditioner from contaminating the T-joints, conditioner should not be applied beyond the corresponding dowel or bolt holes in the block. The correct application pattern is shown below:

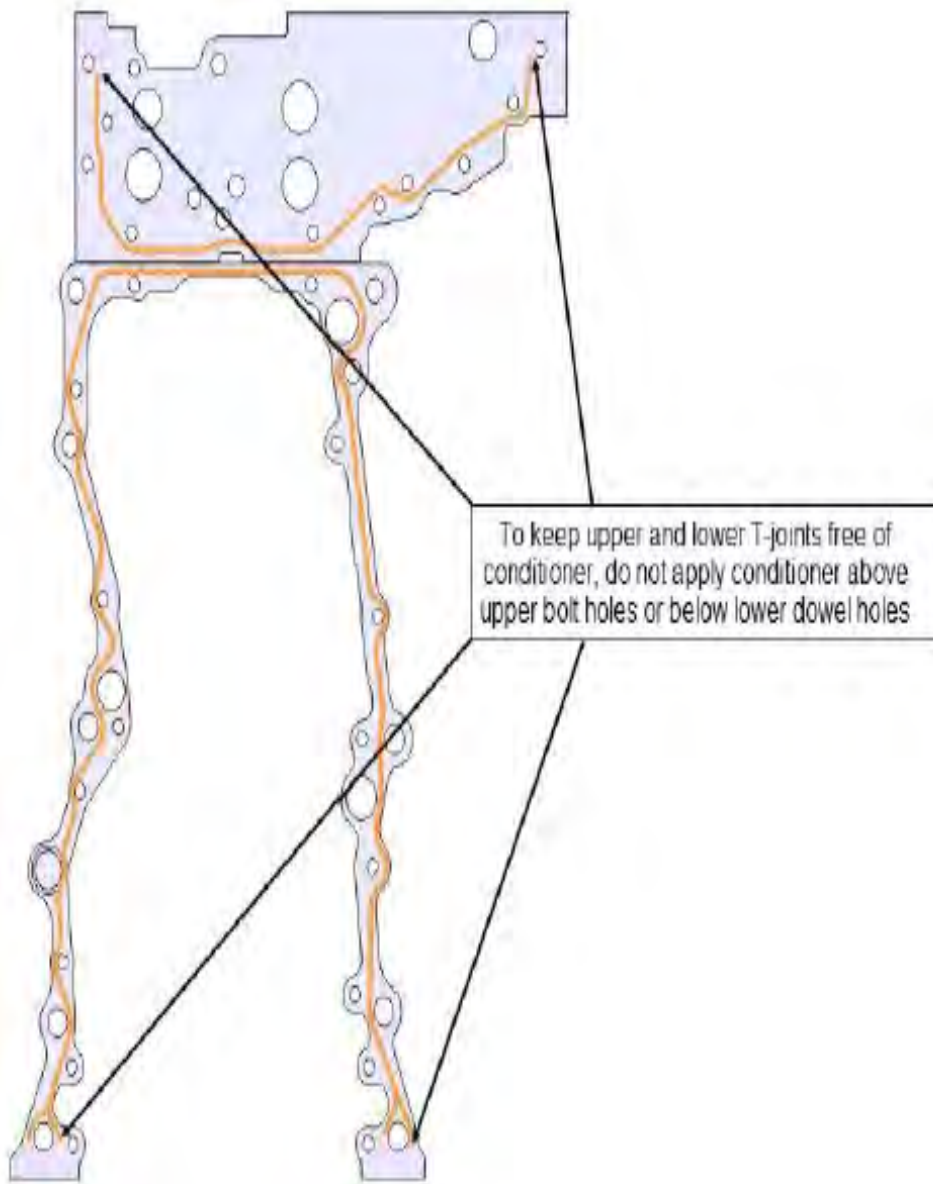

2a. IMPORTANT: For a turbo compound engine, seal conditioner should be applied **to the surface of the TC unit.**



3. Install the TGP on the engine block per the Impact procedure. **Remove any excess seal conditioner from T-joints.**
4. Refer to the Impact operation for installation of timing gears and set-up procedures.
5. Prior to the installation of the flywheel housing (FWH) onto the TGP, clean the FWH mating surface of any oil, grease, dirt. Inspect and clean the TGP bolt holes in the FWH.
6. Complete the installation of the flywheel housing onto the engine following the procedure in Impact.
7. After the flywheel housing has been reinstalled, wipe away any excess conditioner from the joints.

Video

A video of the procedure can be found below. Click the YouTube button in the lower right-hand corner of the video to view the video full-size.



Timing Gear Plate Repair

Job Aid

A Job Aid outlining repair times, document information, and a tool list can be found below (click on the pictures to expand to a larger size).

Timing Gear Plate, Integrated Plate
Job Aid

Special Tools

<p>Coolant Extractor 85112740</p> <p>Drain Hose 9996049</p> <p>Disassembly Tool J-44773</p> <p>Cranking Tool 88840317</p> <p>Fixture 88800570</p> <p>Impact Wrench 9996400</p> <p>Puller 9990192</p> <p>Disassembly Tool 88800502</p> <p>Guide 9998267</p> <p>Rocker Indicator 9999683</p>	<p>Magnetic Stand 9999696</p> <p>Timing Kit J-44514B</p> <p>Assembly Tool 88800619</p> <p>Assembly Tool 9990166</p> <p>Align Tool 85111422</p> <p>Setting Tool 8880031</p> <p>Align tool 9990024</p> <p>Fixture 9996857</p> <p>Transmission jack and plate</p> <p>TC Support Plate 88800826</p>	
--	---	--

<p>1) Secure the truck for service, disconnect negative cable.</p> <p>2) Drain air and coolant.</p> <p>3) Remove interior components.</p> <p>4) Remove transmission.</p> <p>5) Remove air cleaner box, CAC pipe and Diffuser pipe.</p> <p>6) Remove EGR valve, EGR crossover pipe, valve cover, spacer frame, and upper timing cover.</p> <p>7) Remove all electrical, coolant lines, air lines, and brackets from the rear of the engine.</p> <p>8) Remove air compressor, starter, and tandem pump.</p>	<p>9) Remove oil pan and Remove oil filters.</p> <p>10) Place the engine on TDC.</p> <p>11) Raise and support the engine and Remove engine mounting brackets from flywheel housing.</p> <p>12) Remove engine mounts from the frame.</p> <p>13) Remove clutch, pressure plate, and flywheel.</p> <p>14) Install TC support tool (TC engine Only).</p> <p>15) Remove all hardware securing the flywheel housing and remove the flywheel housing.</p> <p>16) Remove timing gears</p> <ul style="list-style-type: none"> - Tandem idler rear (a puller may be required to remove the gear) - TC Idler Gear (TC Engine Only) - Cam gear, Double idler gear and Adjustable idler gear <p>17) Install aligning dowels, removed TGP hardware, and remove TGP.</p>	<p>Teardown 0-4 Hrs.</p> <p>Teardown 5-8 Hrs.</p>
<p>18) Apply seal conditioner to the block and head.</p> <p>19) Install TGP and new mounting bolts.</p> <p>20) Install all timing gears verifying timing and gear lash are correct.</p> <p>21) Make sure to remove alignment dowels.</p> <p>22) Apply seal conditioner to the TGP.</p> <p>23) Install flywheel housing and torque all securing hardware to spec.</p> <p>24) Remove TC support tool. (TC Engine Only)</p> <p>25) Install engine mounting brackets to flywheel housing and engine mounts in frame.</p> <p>26) Lower engine onto the engine mounts, install and torque engine mounting bolts.</p> <p>27) Clean and install oil pan, hook up level sensor, dipstick, and fill tube.</p> <p>28) Replace oil filters and fill engine with new oil.</p> <p>29) Install rear main seal, flywheel, and starter.</p> <p>30) Install upper timing cover, valve cover, and EGR cross over pipe.</p> <p>31) Install tandem pump, air compressor, air compressor line and connection.</p> <p>32) Connect E1 (engine interface) connector.</p>	<p>33) Install all electrical, coolant lines, air lines, and accessories from the rear of the engine.</p> <p>34) Install EGR valve, EGR hot pipe, diffuser pipe, filter pipe, and install hot side CAC pipe.</p> <p>35) Install air cleaner housing and turbo inlet pipe.</p> <p>36) Install clutch and pressure plate.</p> <p>37) Ready transmission for installation and install trans.</p> <p>38) Route and secure battery cables, trans cooler coolant lines, air lines, and electrical harness.</p> <p>39) Install drive line.</p> <p>40) Fill engine with coolant.</p> <p>41) Connect batteries, start engine and check for leaks.</p>	<p>Install 9-13 Hrs.</p> <p>Install 14-17.8 Hrs.</p>
<p>Training Video available at VolvoTrainingsupport.com</p>		
<p>Additional Communications</p> <p>Turbo Compound Support Bracket TSB M-212-001 Timing gear plate, Inspectors/Repair</p> <p>Timing Gear Plate Install Repair operation 2152-03-03-05 (Timing Gear Plate, Replacement) in Impact</p>		





Volvo TGP Job Aid v3.pdf

Warranty Information

Warranty Information can be found in the Warranty Operations Manual, [6.2.1.1 - TIMING GEAR PLATE - Clean Claim Template](#).

- Log in to TDP prior to clicking the link.

Additional Information

• Use of recommended oils is advised. The Recommended Oil List can be found in Impact or by clicking [here](#).

 Tags

[volvo](#) [unlocking uptime](#) [tgp](#) [oil leak](#)

[timing gear plate](#)

Categories 

Make and Model > Volvo > VNL

Make and Model > Volvo > VNR

Make and Model > Volvo > VNX

Make and Model > Volvo > VAH

Make and Model > Volvo > VHD

Powerplant > Volvo > D11

Powerplant > Volvo > D13

Vehicle System > Engine

 Live UI

Related links and attachments

[Volvo TGP Job Aid V3](#)



Feedback

[Give feedback](#)

to help improve the content of this article

Timing Gear Plate, Inspection and Repair

V-212-003

(December 2022)

Valid for

All Volvo Powered Trucks 2017 to current

Case description

Volvo Trucks with an 11L and 13L engine utilize two types of timing gear plates. In some instances, the timing gear plates may show evidence of an oil leak or oil weep. The information in this publication describes the differences between the two types of timing gear plates used, the inspection criteria for determining an oil weep vs an oil leak, and the recommended best practices for how to properly diagnose a leak, and what is considered a valid repair and updated repair instructions.

Types of timing gear plates

Wet seal plates are multiple time use and can be removed, cleaned and reinstalled with new sealant. Wet seal plates are used on 11L-13L engines from the start of production to current on the 11L and through April 2018 on the 13L VGT engines. The 13L turbocompound engine has never been built using the wet seal plate.

Important Note
13L Engine with a wet seal plate can be upgraded to the new integrated seal plate but will require additional components to be replaced. Refer to TPI 212-031, Timing Gear Plate for required parts list.

Integrated seal plates were introduced into production in 2017 models built with the 13L turbocompound engine and 13L VGT engines built after April 2019. If a leak is found on an integrated seal plate or any damage is found to the integrated seal the plate must be replaced. The integrated plate is not repairable and must be replaced if any damage is found.

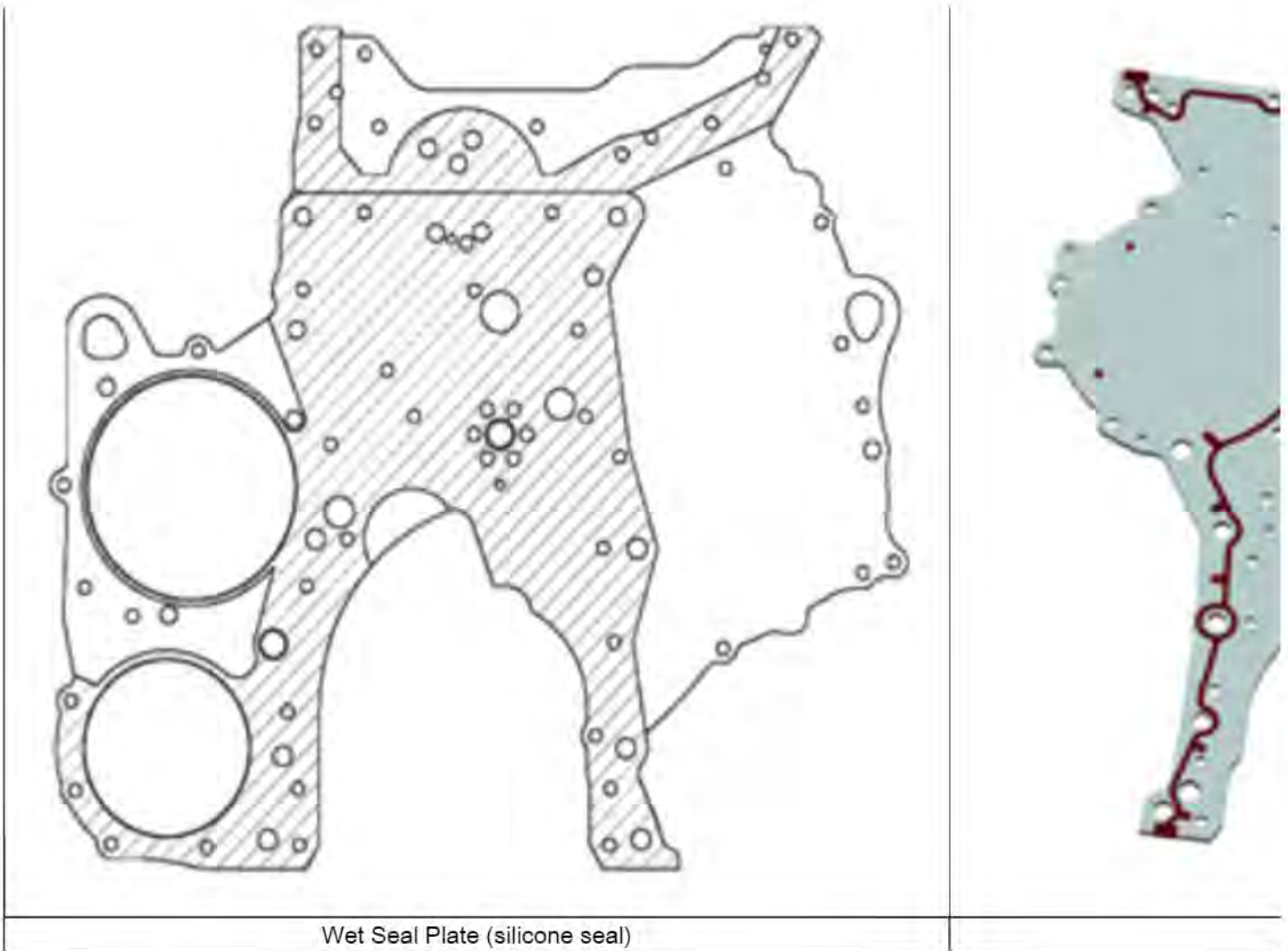

Repair criteria

Oil leak can be classified into two different categories, a weep, or an active leak.

Oil Weep is determined by the appearance of a thin accumulation of oil on the exterior of a part. The area will look like a dark stain or look damp in appearance (but not wet or dripping) and will likely collect dust and dirt.

Note: An oil weep is a normal condition seen around mechanical joints and does not require a repair.

Oil Leak is determined by the identification of oil actively accumulating on the exterior of a part. The area will be visibly saturated, can be seen actively accumulating and running from the area.

Note: An active leak is the only leak that is considered a valid warrantable repair.

Use the images below for a visual reference of the leak categories. If farther assist in needed determining the leak category, please follow normal support procedures.

Note: If an integrated seal plate is leaking or if damage is found to the seal, it must be replaced with a new one. It cannot be repaired using silicone.

Reference images of an oil weep (not a valid warrantable repair)

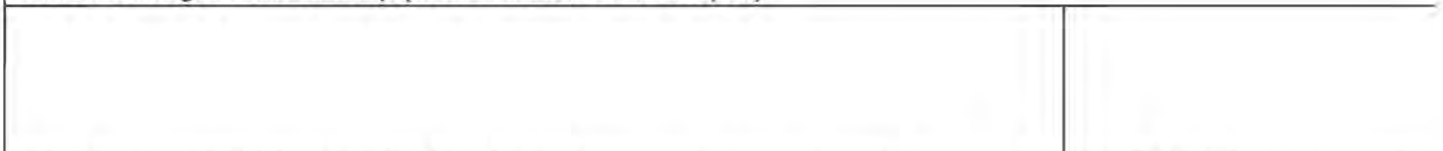



Dark spot or stain

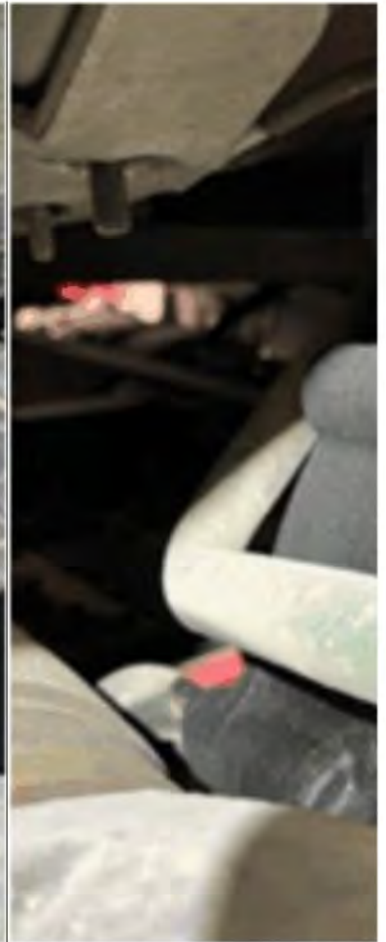

Colle

Reference images for an oil leak (valid warrantable repair)





Oil actively leaking

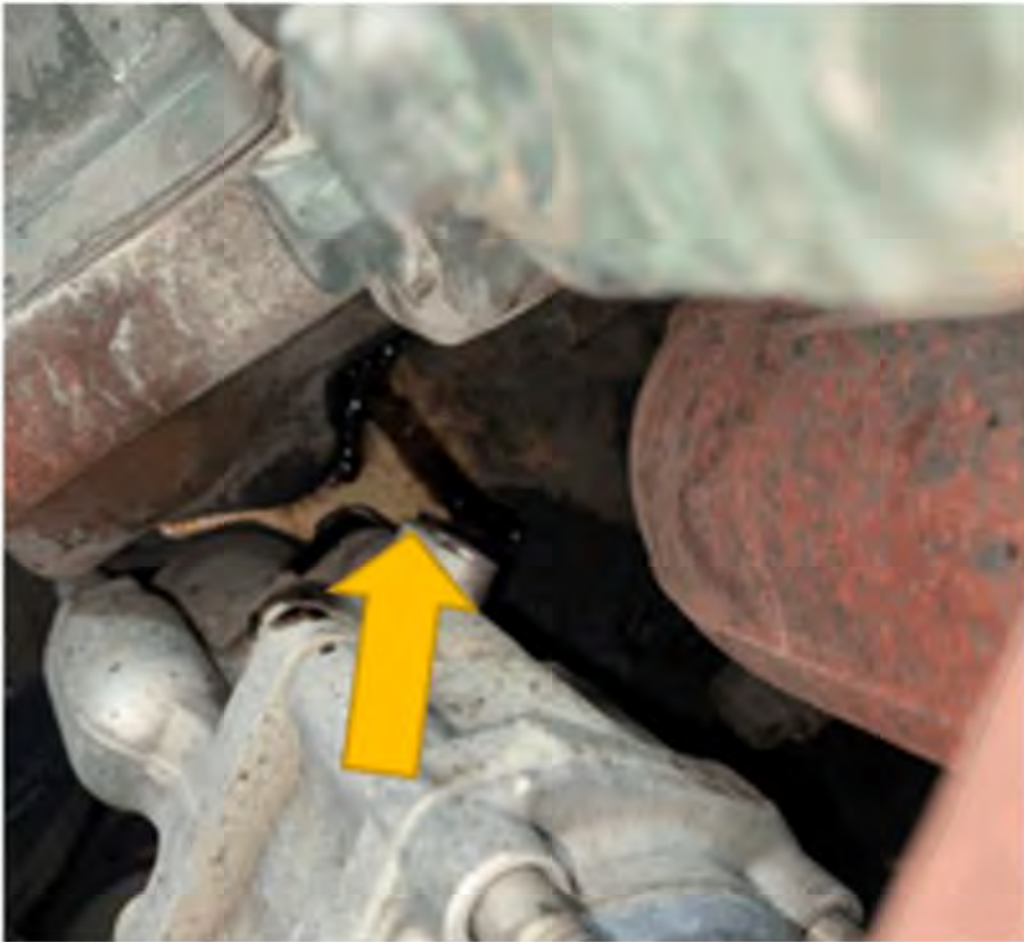

Oil actively running down joint

11L-13L Engine Oil Leak Diagnose

Note: When diagnosing a suspected timing gear plate leak, it is important to understand the difference between a weep and a leak.

- . Park the vehicle on a level surface.
- . Apply the parking brake.
- . Place the gear lever in neutral.
- . Install the wheel chocks.

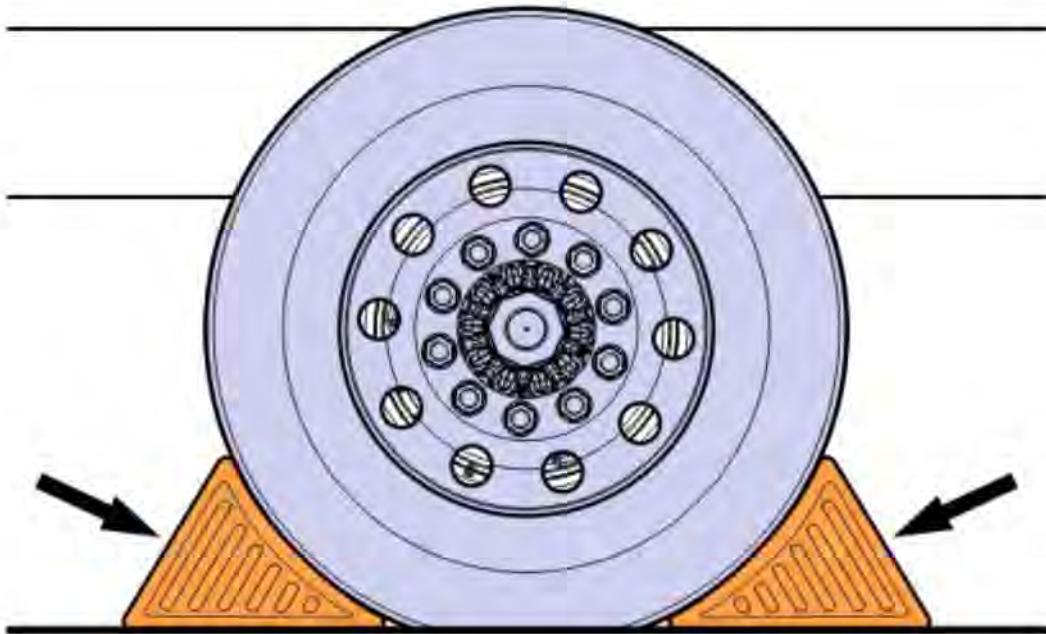

- Unlatch and raise the hood.
- Visually inspect the Timing Gear Plate (TGP) for an active leak.
- If a **weep** is found (dark stain/dust and dirt) no further diagnostics is needed. Release truck back into service.
- If a **leak** is suspected, follow the steps below to properly diagnose and repair the leak.

When diagnosing a TGP leak

- A. Prior to cleaning the engine, document the suspected leak with pictures that clearly shows the accumulation of the oil leak as well as pictures of the suspected area.
- B. Thoroughly clean the suspected area.
- C. Load the engine (road test/regen) to get coolant and oil up to operating temperature.
- D. Verify oil is actively leaking.
- E. Document the oil leak with clear pictures of the active leak and the origin point.

Important Note

If further assistance is needed determining a leak request support using the normal process.
--

- Once a leak is determined and documented with pictures, follow Impact repair instruction in function group 2152 for replacement of the TGP.

Important Note

If an integrated seal plate is leaking or if damage is found to the seal, it must be replaced with a new one.

- Verify the leak is repaired and release truck back into service.

Repair Information

Timing gear plate kits are now available for the 13L VGT **24459407** and 13L TC engines **24459389** and includes a new seal conditioner **24533210**. This seal conditioner is used on the integrated TGP seal and is designed to extend the life of the TGP seal. Seal conditioner should be applied to the TGP seal anytime the seal is exposed (TGP replacement, flywheel housing removal, cylinder head removal and TC unit removal).

- When installing a TGP, the seal conditioner should be applied to the back of the block and cylinder head. Make sure not to apply seal conditioner above the top holes of the cylinder head and below the dowel holes at the bottom of the block. (Shown below). Any excess seal conditioner must be cleaned from the bolt holes and T-joints. This is to prevent seal conditioner from interfering with the securing hardware torque and the silicone sealant at the T-joints.

Copyright to this documentation belongs to the Volvo Group. No reproduction, copying, change, amendment or other similar disposal is entitled without prior written consent by the Volvo Group

The information contained herein is current at the time of its original distribution, but is subject to change. The reader is advised that printed copies are uncontrolled.

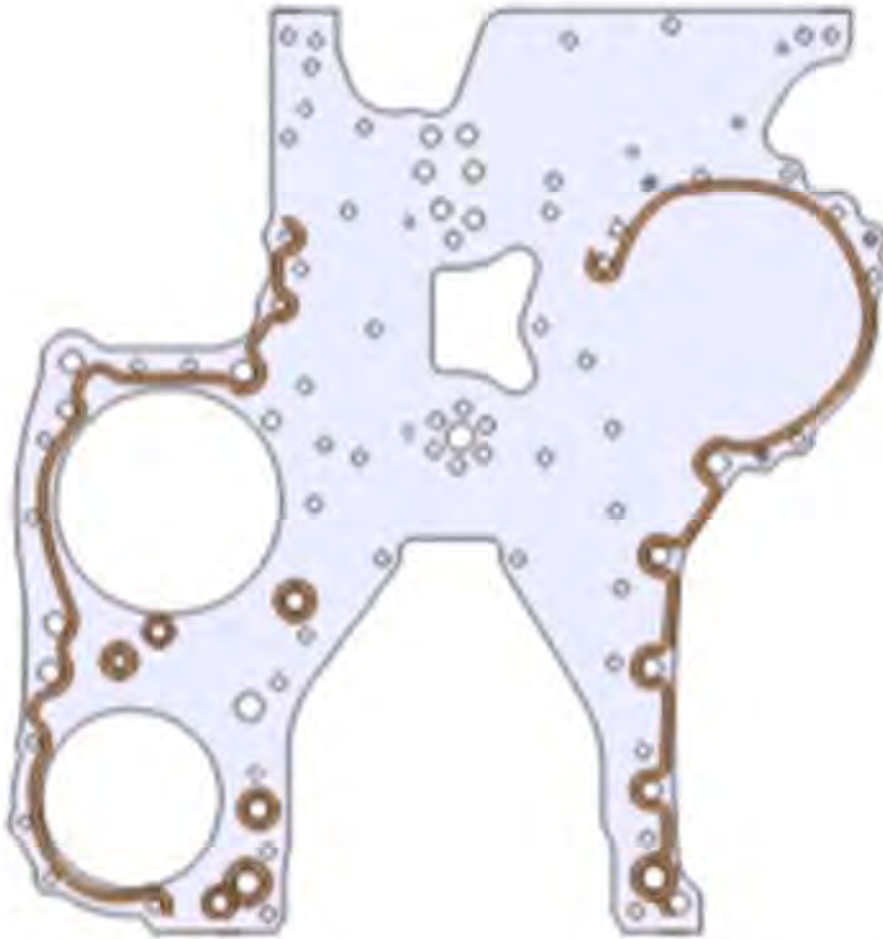

When installing the TC unit, the seal conditioner should be applied to the TC unit not the TGP. (Shown below). Any excess seal conditioner must be cleaned from the bolt holes. This is to prevent seal conditioner from interfering with the securing hardware torque.





Issued by

Technical Service

21527-3 Timing Gear Plate, Replacement

Transmission and Clutch Removed

 Illustrations may differ slightly from the actual vehicle being serviced. However, key components addressed in this information are represented as accurately as possible.

 Colors used in illustrations are for highlighting purposes only and do not correspond to the actual colors of the vehicle.

 All threaded fasteners that do not have a tightening torque specification in the information are tightened to a standard torque. Standard torques are available in the following specification. [▶ Standard Tightening Torques](#)

 CAUTION	
Risk of material damage.	
Any damage or deformation to the EGR (Exhaust Gas Recirculation) pipes can affect their function and lifetime. The corrugated steel bellows are sensitive to dents.	
▶	Use caution when working on or near the EGR pipes.
▶	Do not try to force the pipe into place by bending, twisting, or stretching the bellows.

 WARNING	
Risk of burn injuries.	
Heated components and mechanical parts can cause burns.	
▶	Exercise caution when working with heated components. Always use the appropriate protective equipment.

 WARNING	
Risk of burn injuries.	
The coolant may be hot.	
▶	The cooling system is under pressure and can reach the temperature sufficient to cause burns. Allow the coolant temperature to reach the safe level before starting the work.
▶	Remove the coolant tank cap carefully. Use appropriate protective equipment.

 CAUTION	
Risk of material damage.	
Using the wrong type of oil filter could result in damage to bearings, crankshaft, and connected parts as a result of unfiltered oil entering the lubrication system.	
▶	Only use oil filters approved by the manufacturer.

 CAUTION	
Service Information Advisory.	

If you are not properly trained and certified in this procedure, ask your supervisor for training before you perform it.

▶ You must read and understand the precautions and guidelines in Service Information, Function Group 2, "General Safety Practices, Engine" before performing this procedure.

Special tools

85112740	88800031	88800502	88800570	88800619
88840317	9990166	9990192	9996049	9996400
9998267	9999683	9999696	85111422	J-44514B
J-44773				

1 Unlatch and raise the hood.

2 Remove the lower right splash shield.

3 Remove the lower left splash shield.

4 Perform this procedure when the condition below is met.

Conditions

- Certain vehicle applications may require the engine cover to be removed

▶ Remove the engine cover if needed.



Service hint
To gain better access to the engine.

5 Perform this procedure when the condition below is met.

Conditions

- If the vehicle is equipped with a removable bumper end cap

▶ Remove the end cap.

6 Position the column lifts.

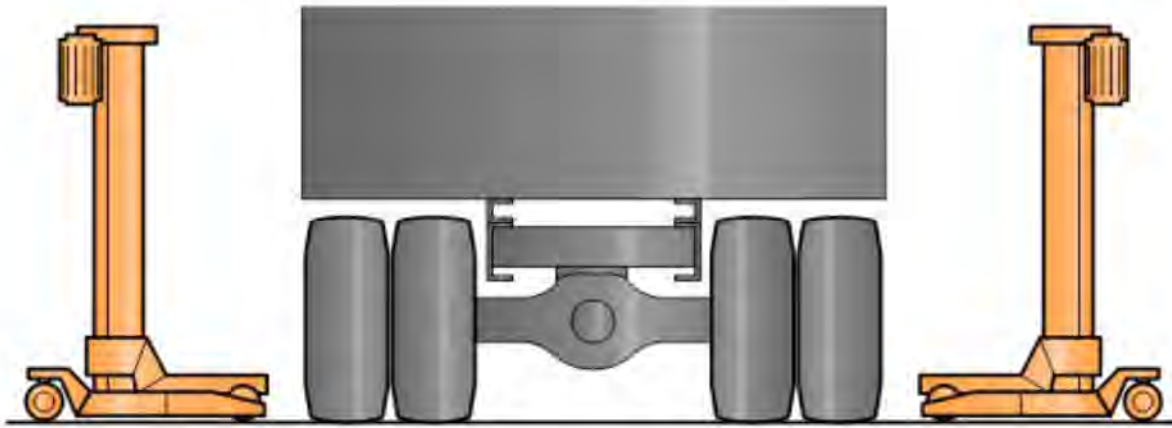

7 Raise the vehicle.

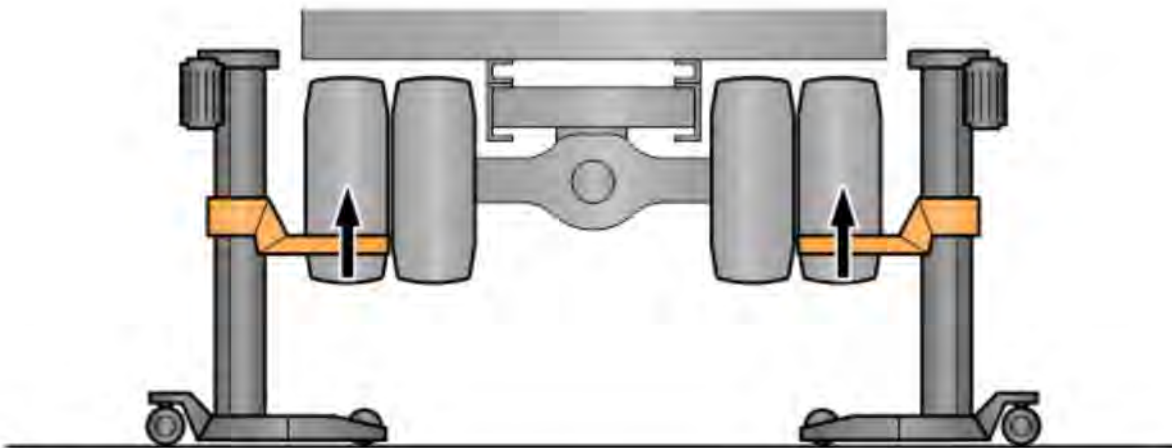

8 Perform this procedure when the condition below is met.

Conditions

- If the coolant is not drained, then drain the coolant
- ▶ Drain the cooling system using either a coolant extractor or a drain hose and pan.

Required material

COOLANT EXTRACTOR/INJECTOR [85112740](#)

DRAIN_HOSE [9996049](#)



Note

Take the collected coolant to a recycling facility as per local safety regulations.

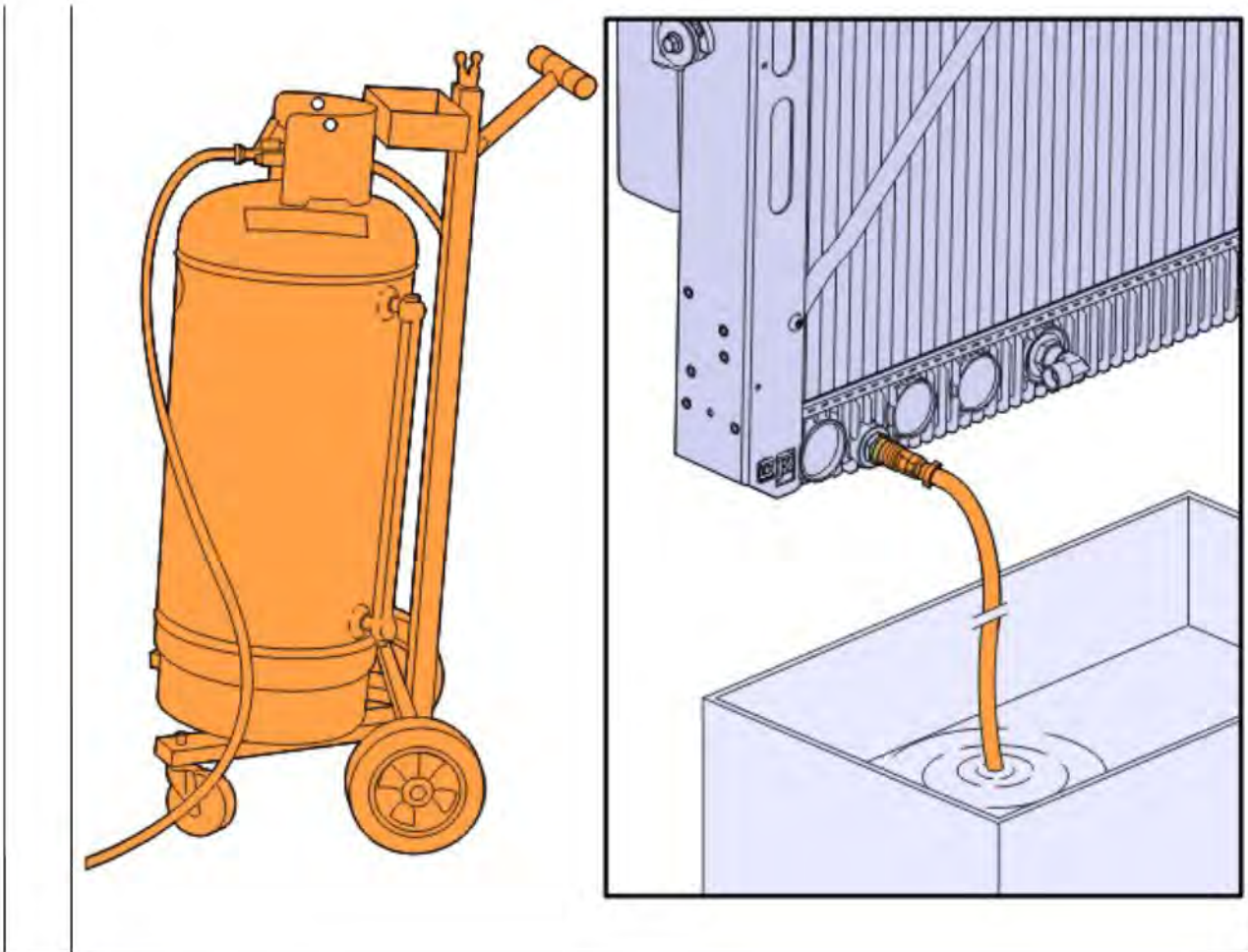

9 Loosen the clamps.



Note

Note the orientations and the positions.

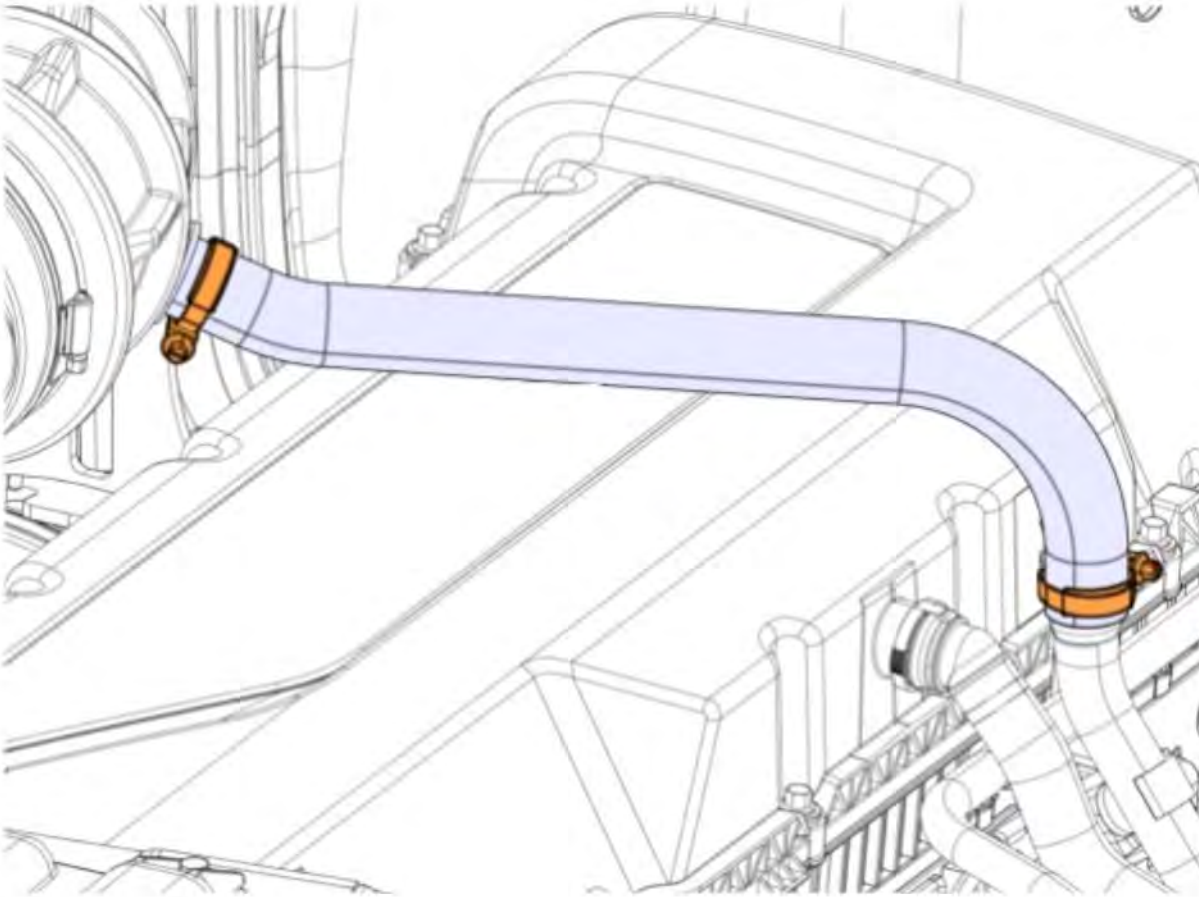

10 Remove the hose.

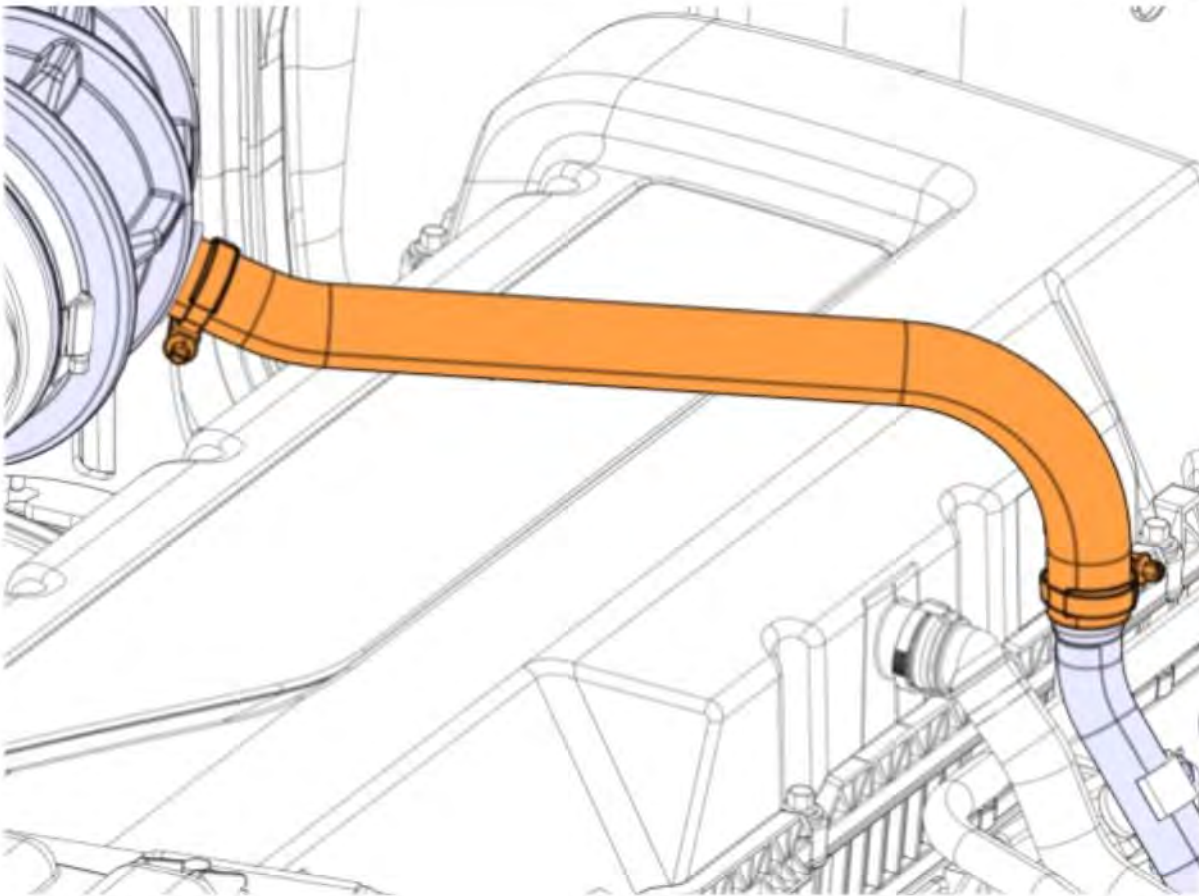

11 Remove the V-clamps.

**Note**

Note the position.

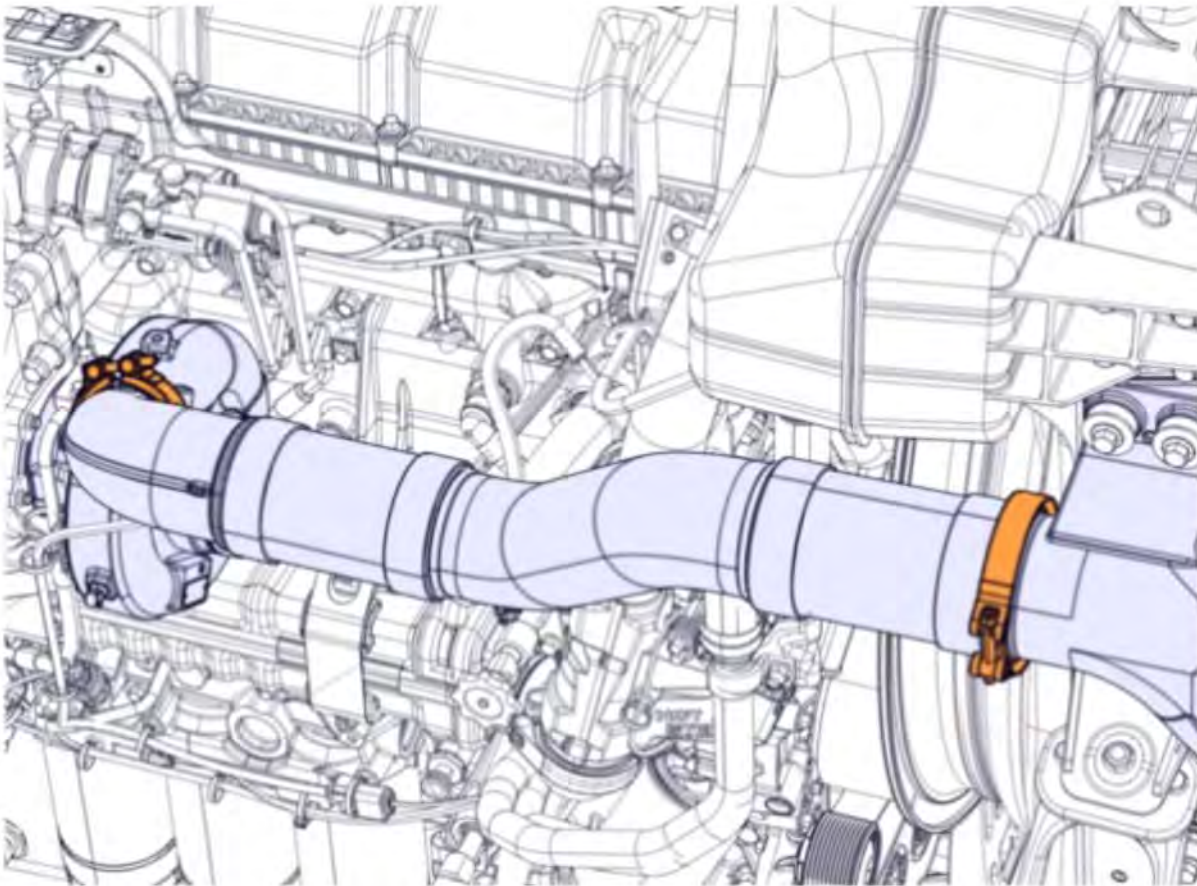

12	Remove the charge air pipe.
----	-----------------------------

13	Remove the seals.
----	-------------------

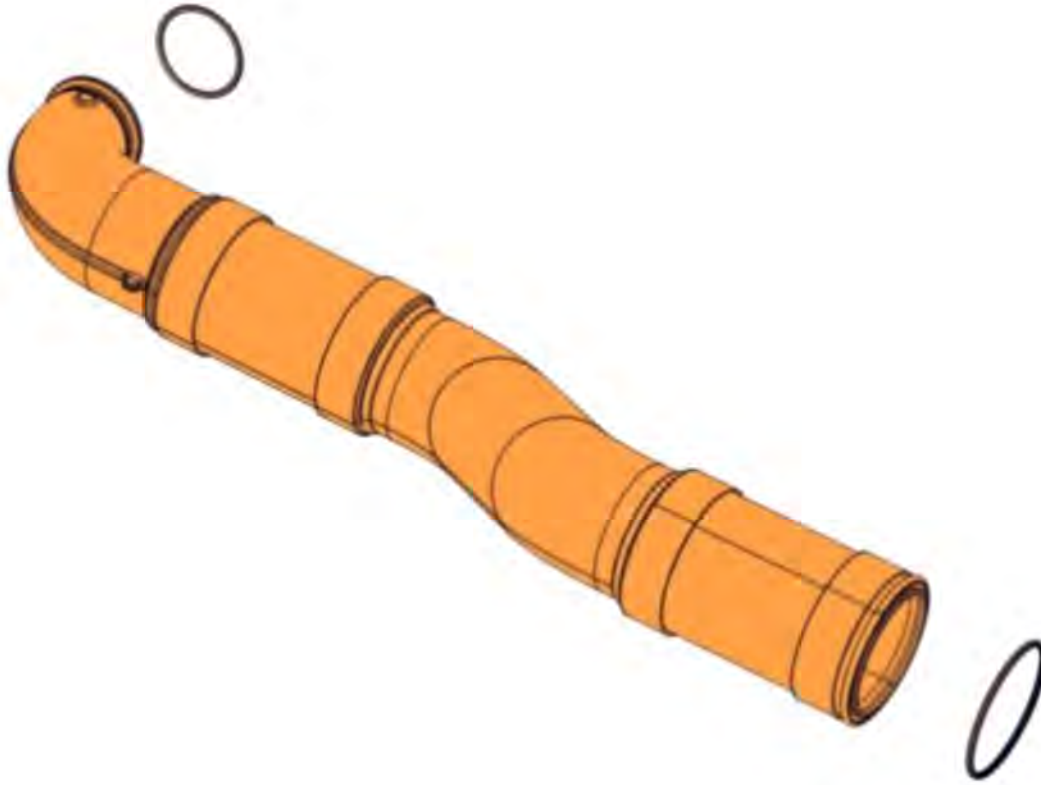

14 Loosen the clamps.



Note

Note the orientations and the positions.

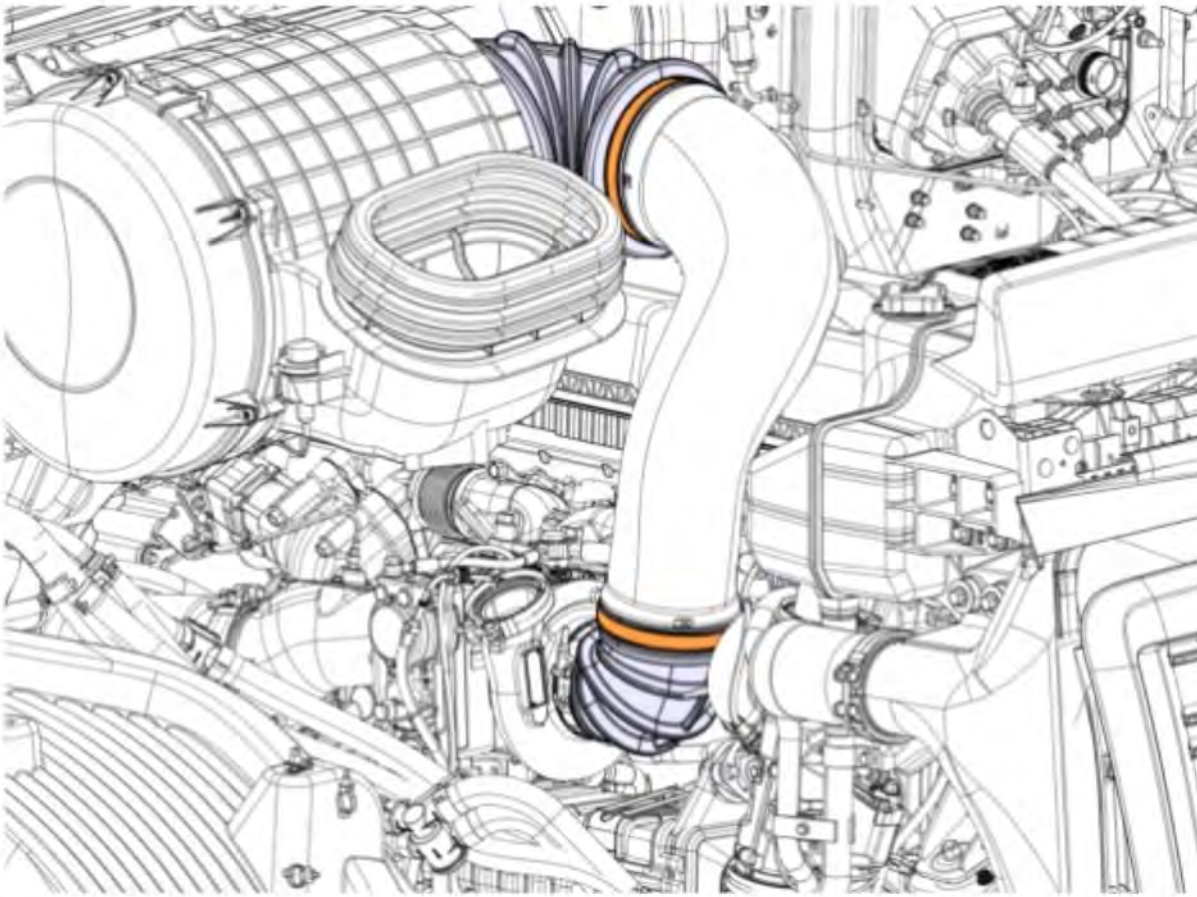

15 Remove the air duct.

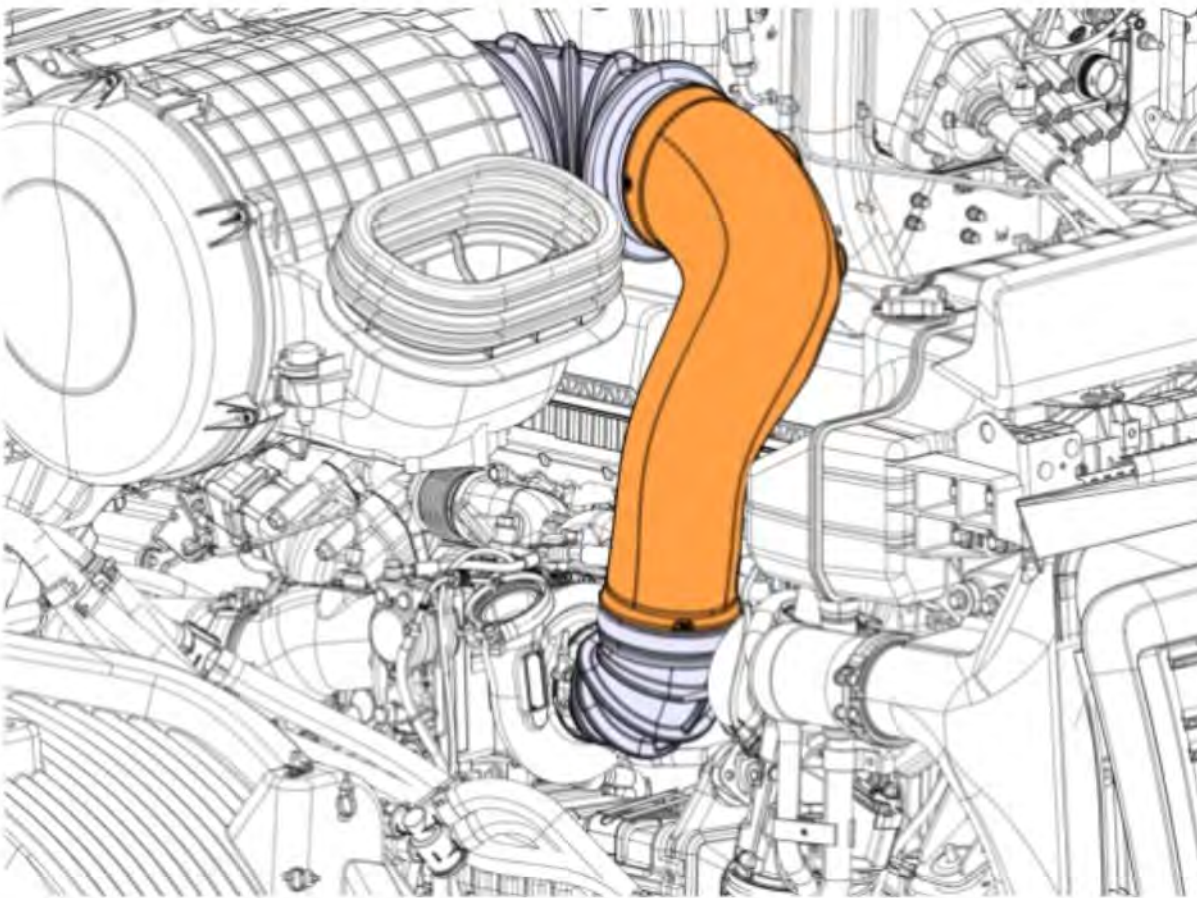

16 Remove the screws.

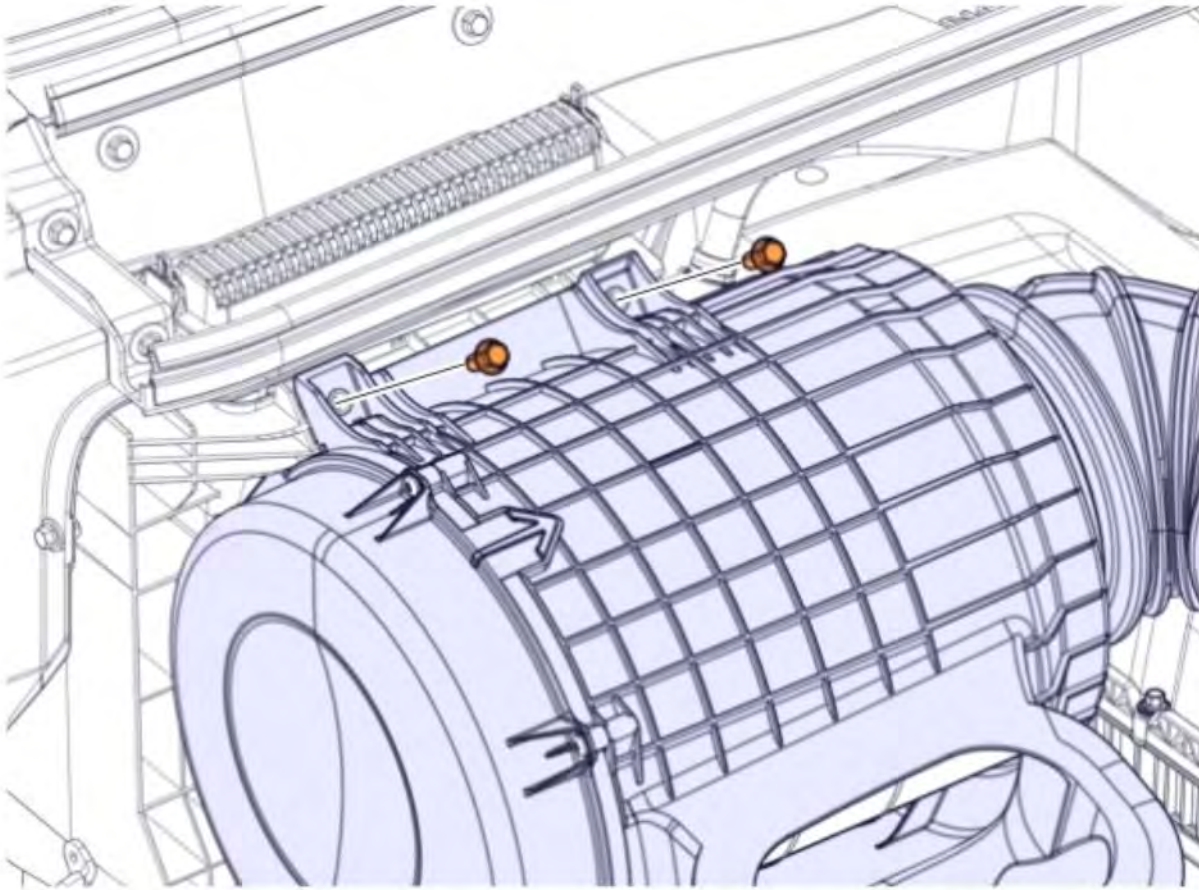

17 Remove the air filter housing.

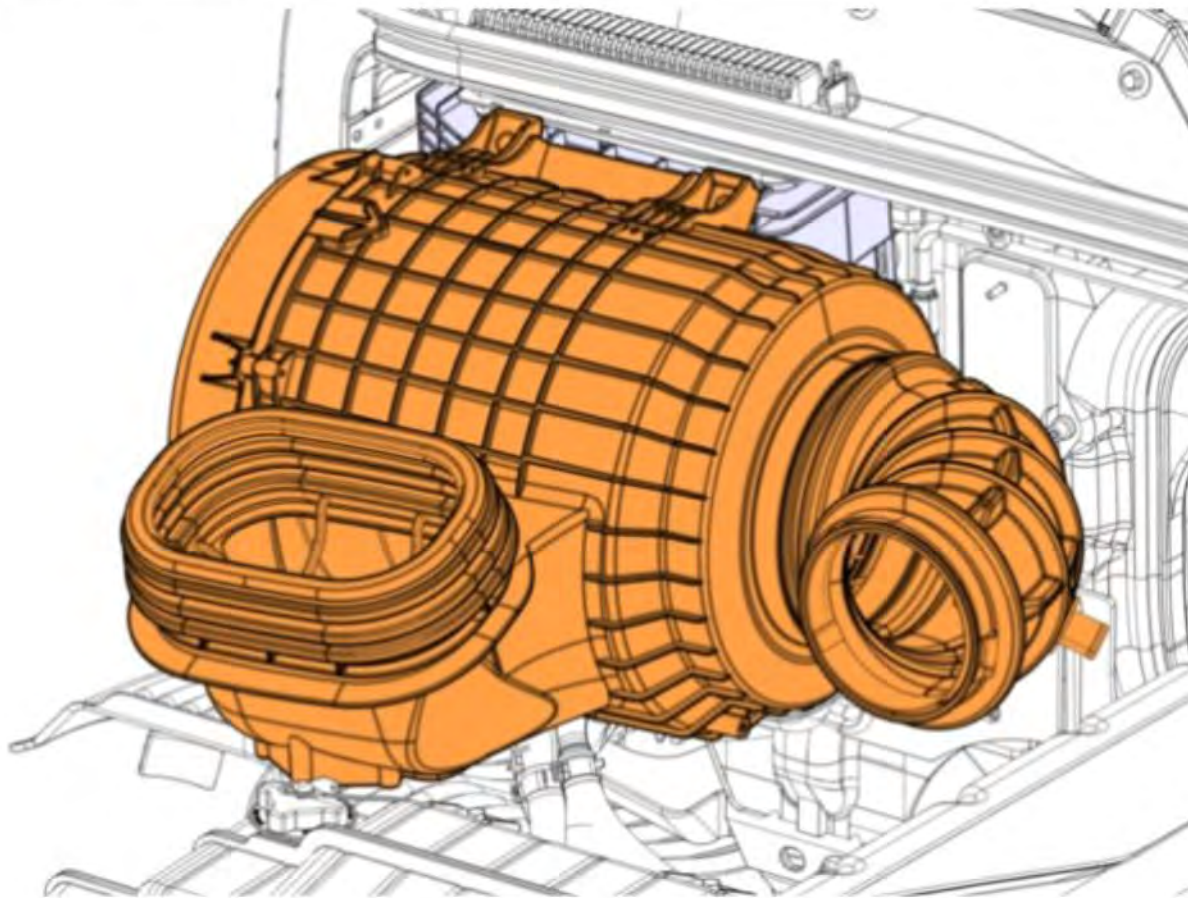

18 Loosen the clamp.

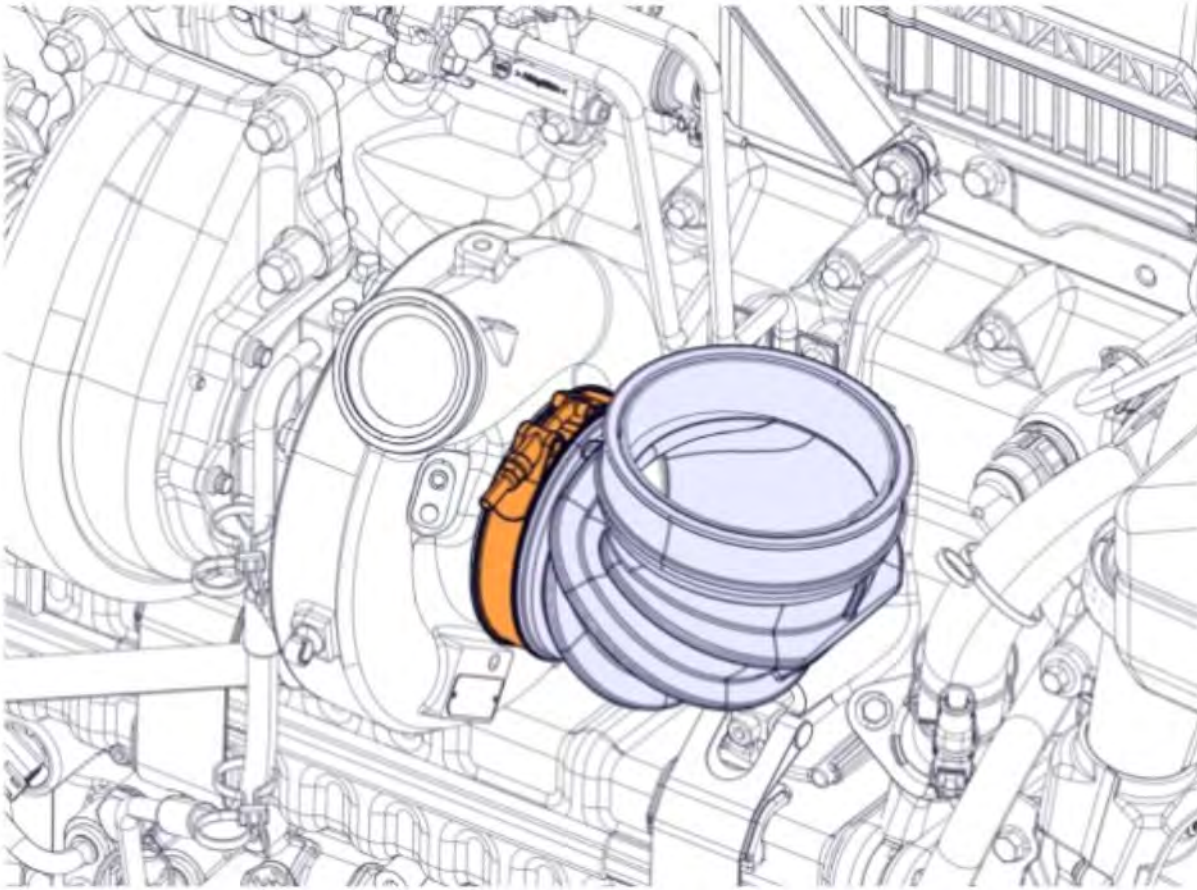

19 Remove the duct.

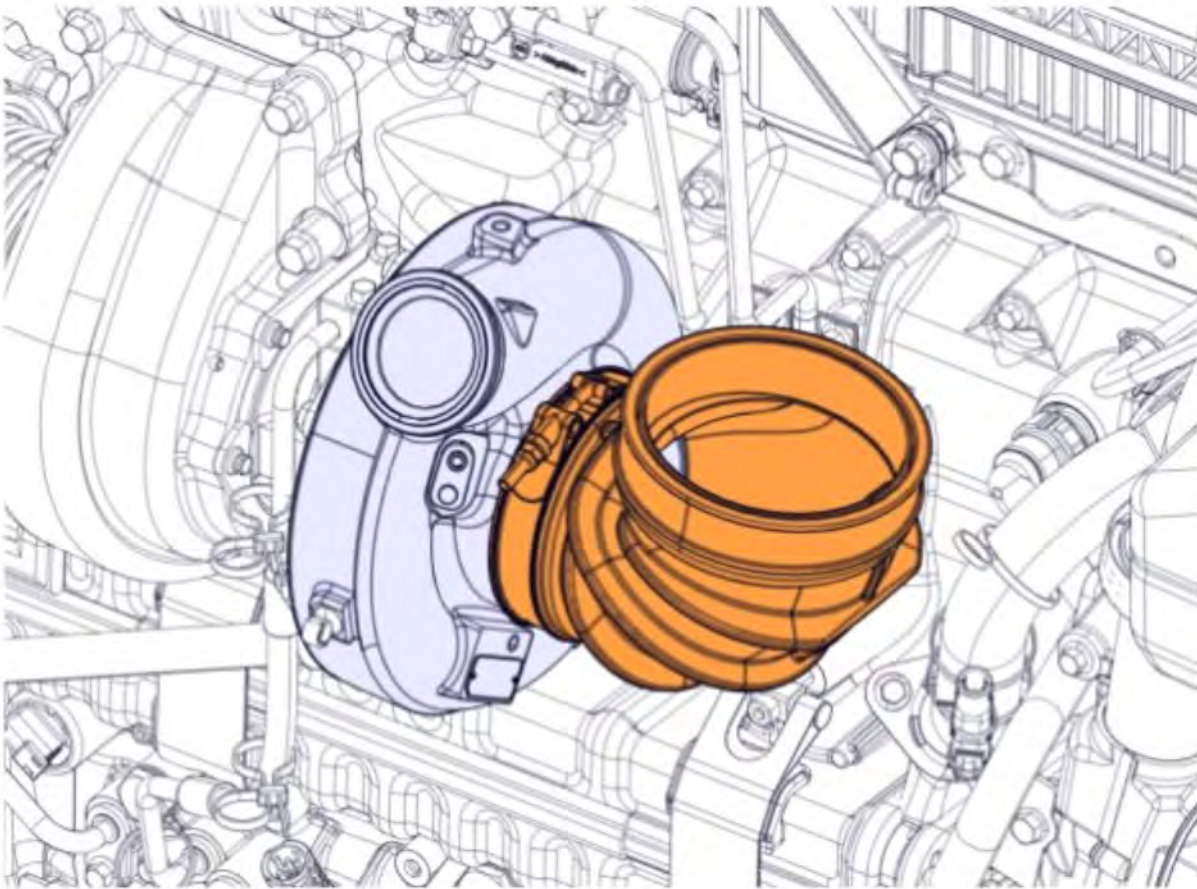

20 Disconnect the connector.

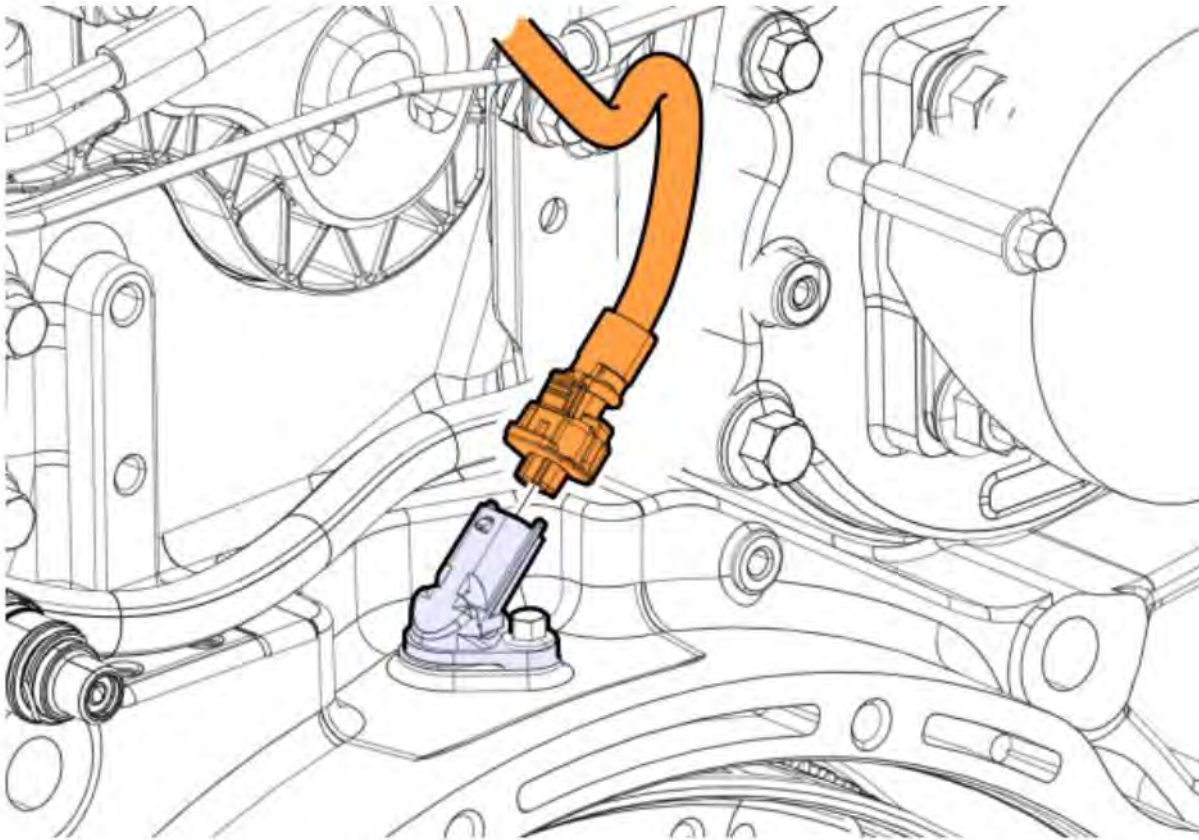

21	Remove the screw.
----	-------------------

22	Remove the sensor.
----	--------------------

23	Remove the O-ring.
----	--------------------

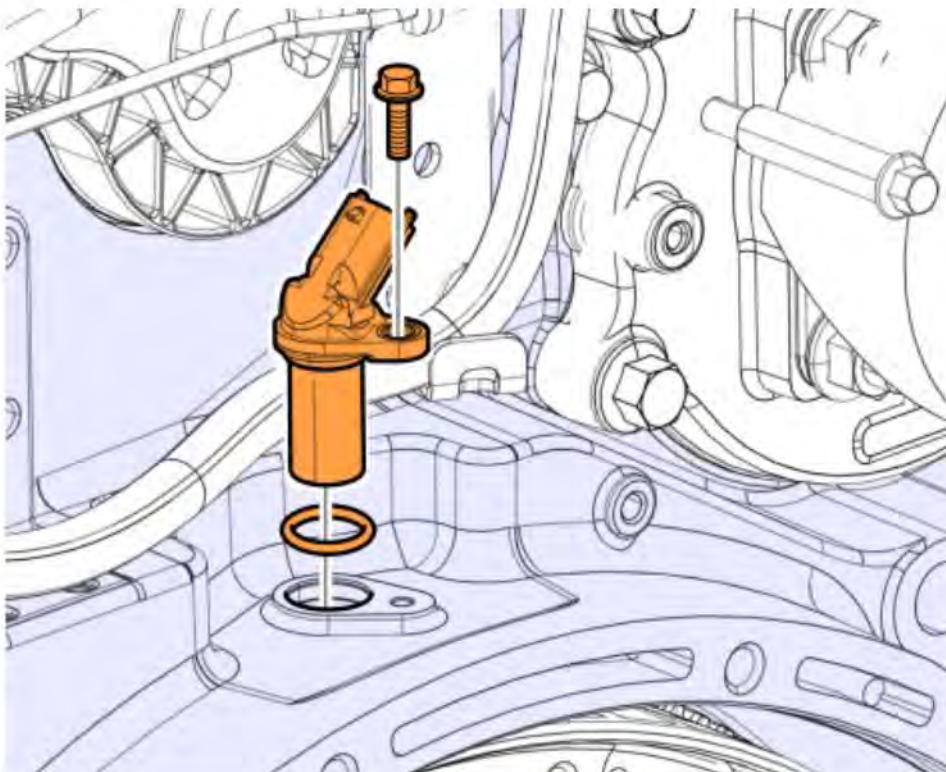

24	Disconnect the connector (1).
----	-------------------------------

25	Remove the screw (2).
----	-----------------------

Copyright to this documentation belongs to the Volvo Group. No reproduction, copying, change, amendment or other similar disposal is entitled without prior written consent by the Volvo Group

The information contained herein is current at the time of its original distribution, but is subject to change. The reader is advised that printed copies are uncontrolled.

26	Remove the heat shield (3).
----	-----------------------------

27	Remove the sensor (4).
----	------------------------

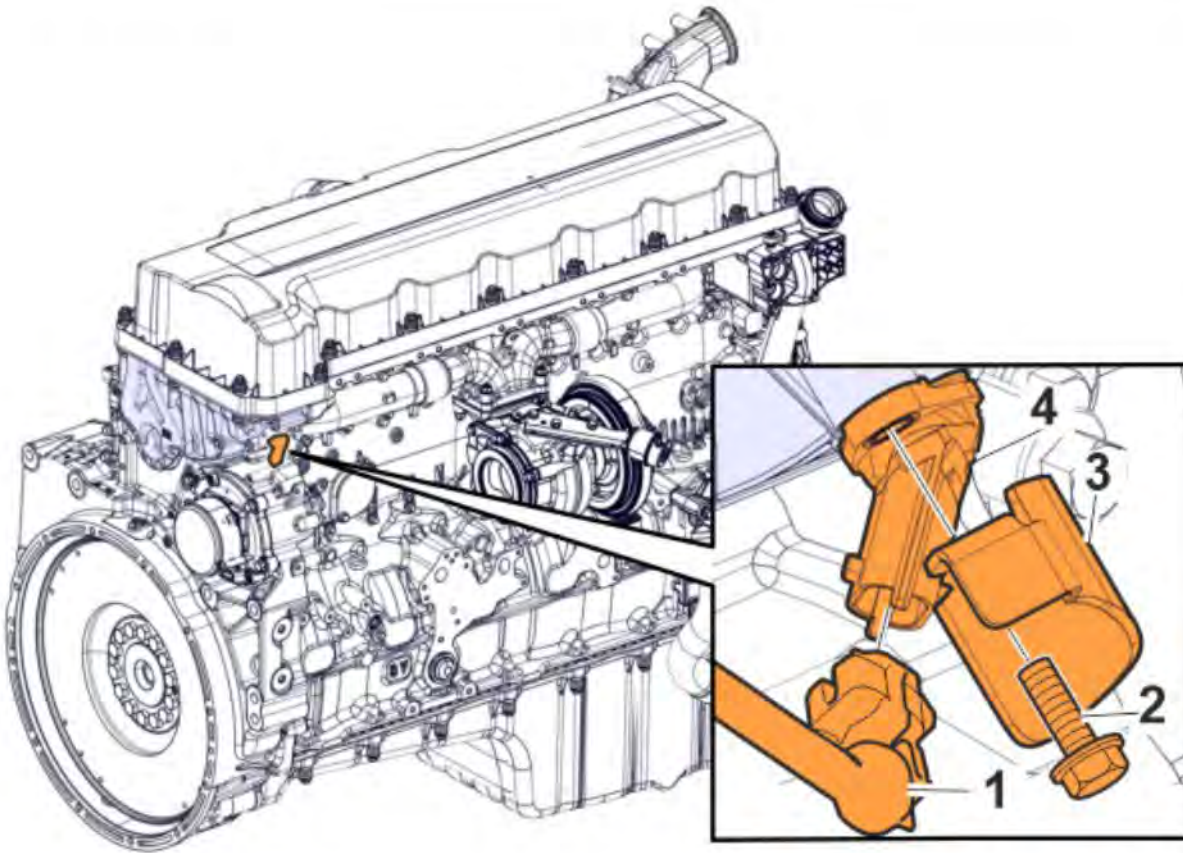

28	Remove the O-ring.
----	--------------------

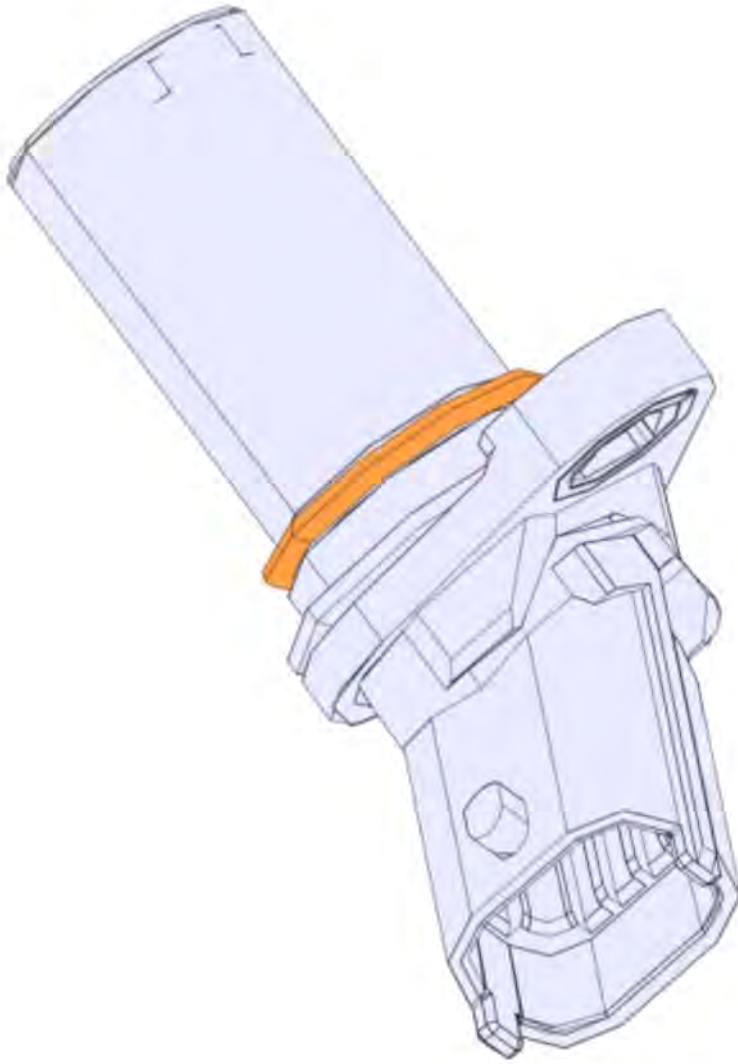

29	Remove the shims as needed.
----	-----------------------------

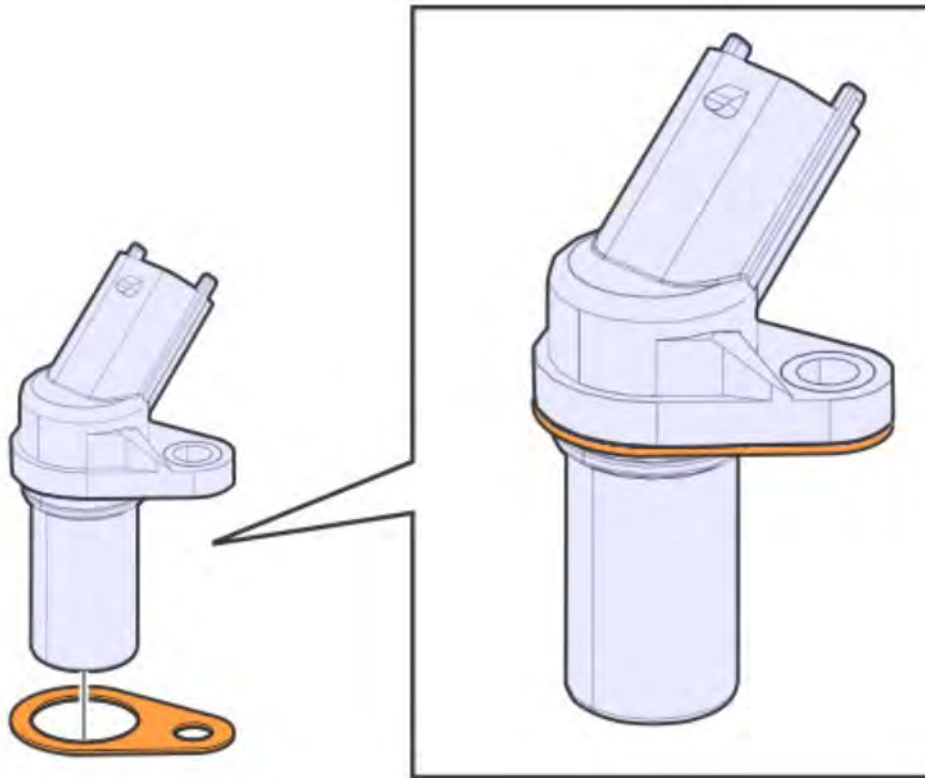

30	Loosen the clamp.
----	-------------------

31	Remove the hose.
----	------------------

32	Remove the screws.
----	--------------------

33	Remove the clamp.
----	-------------------

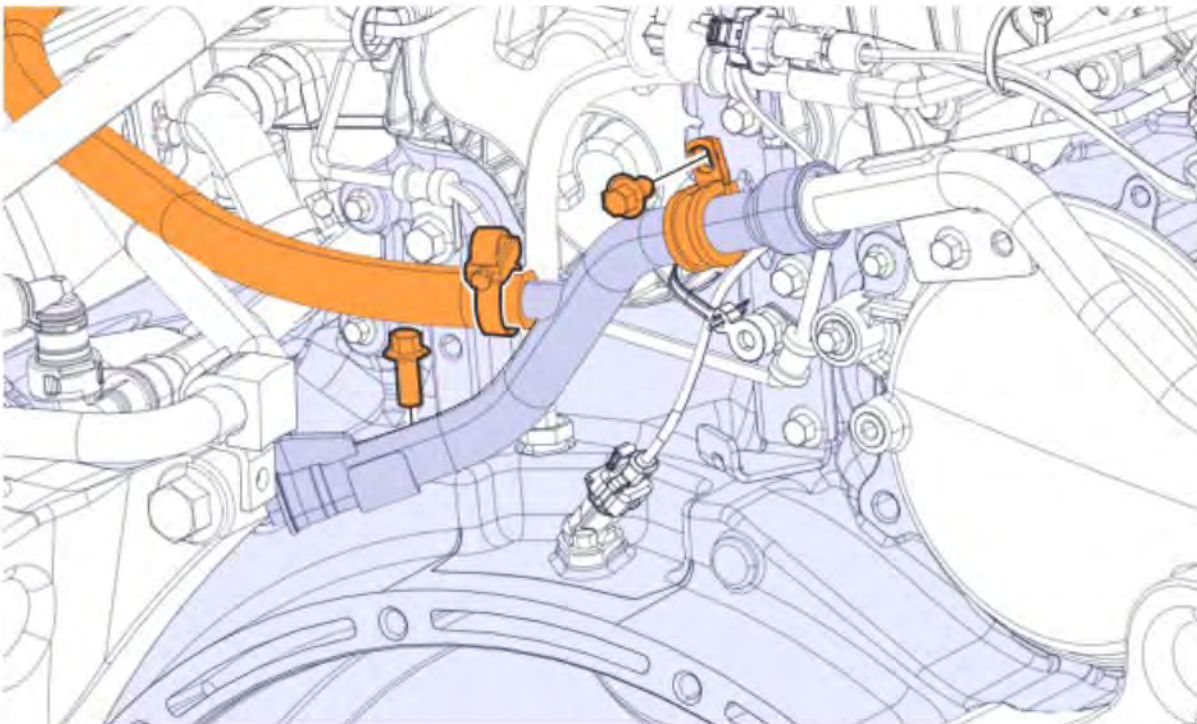

34	Remove the pipe.
----	------------------

35 Remove the seal.

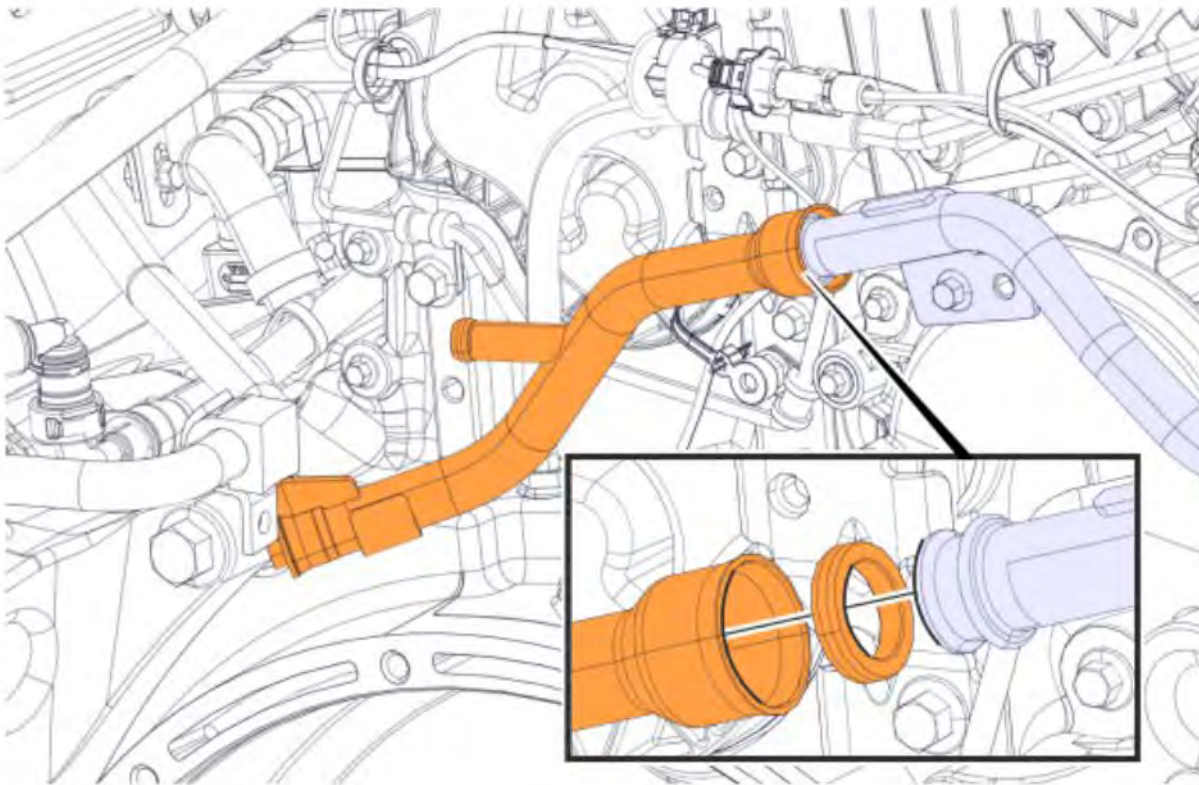

36 Remove the screws and clamps.

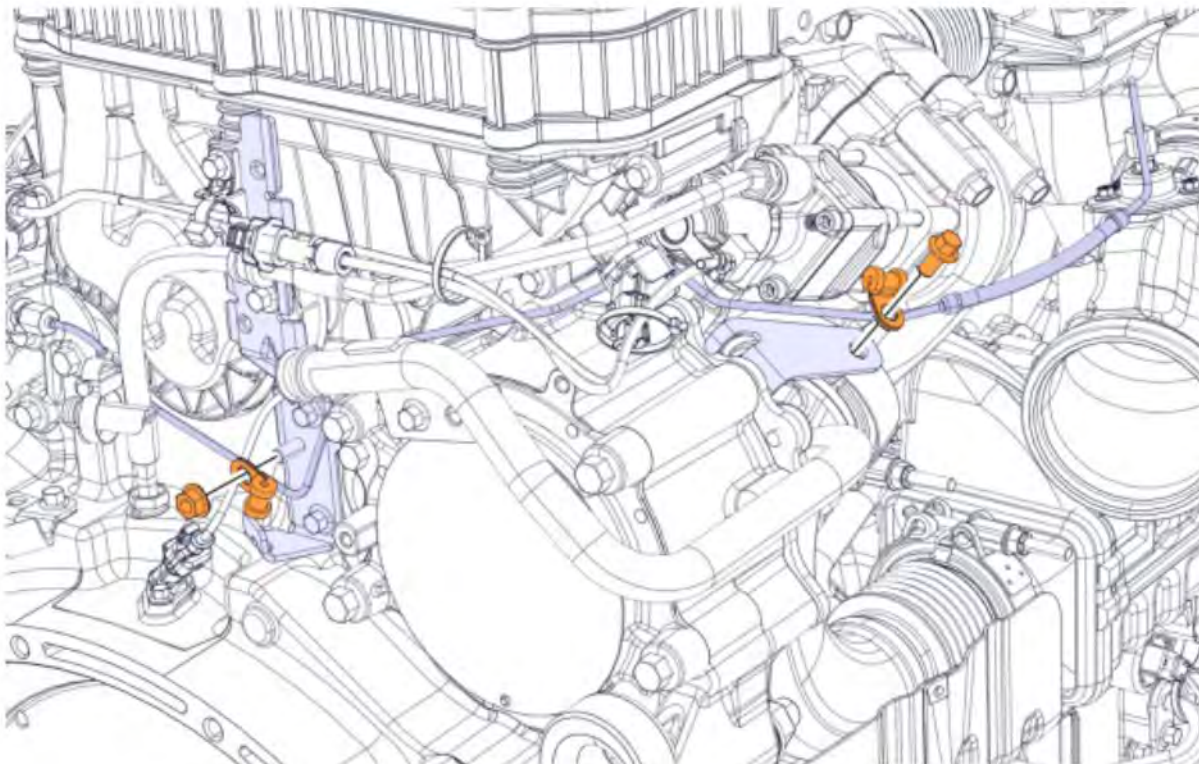

37 Loosen the nuts.

38 Remove the pipe.

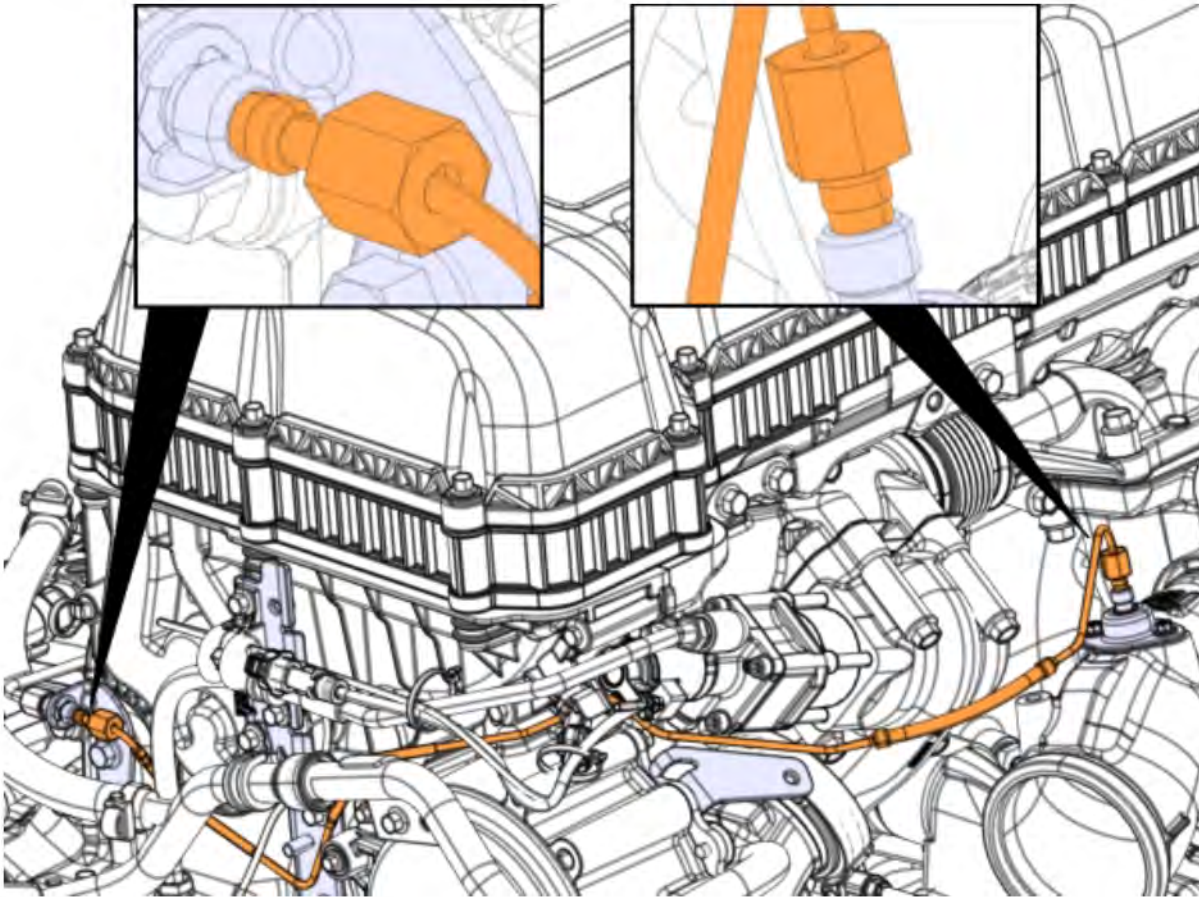

39	Remove the nut.
-----------	-----------------

40	Remove the cable terminal.
-----------	----------------------------

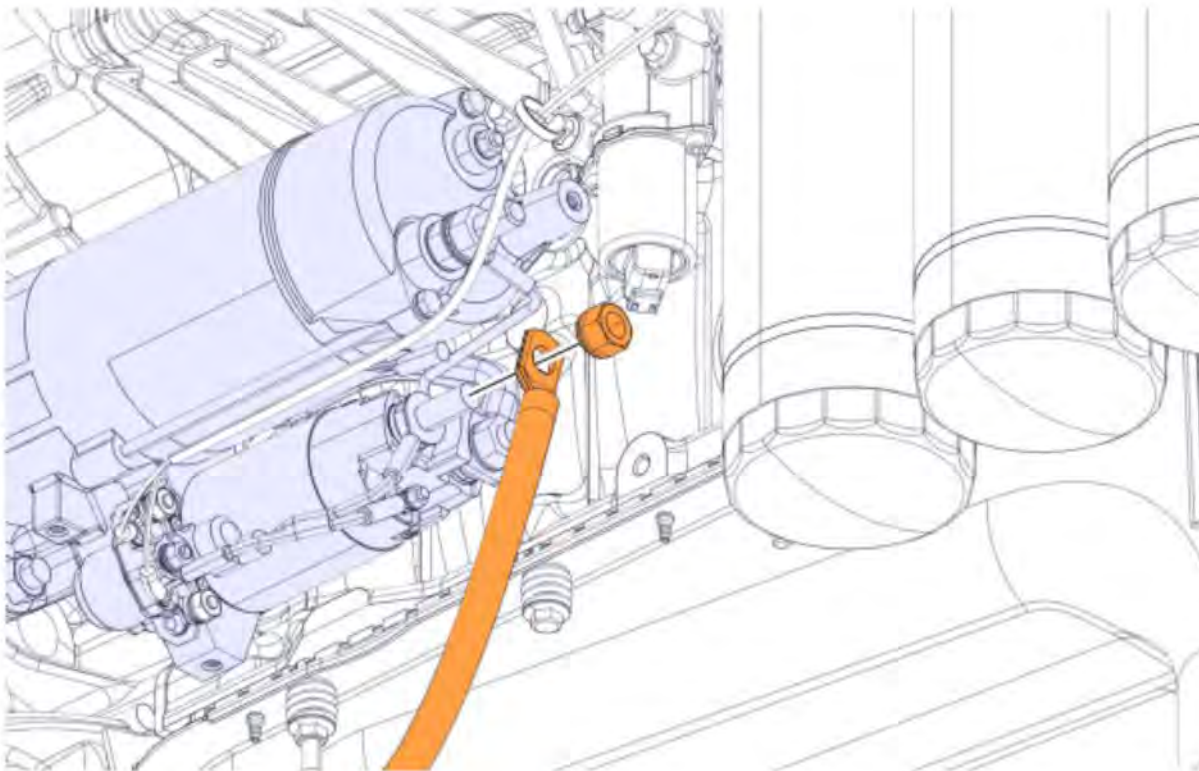

41	Remove the nuts.
-----------	------------------

42	Remove the cable terminals.
-----------	-----------------------------

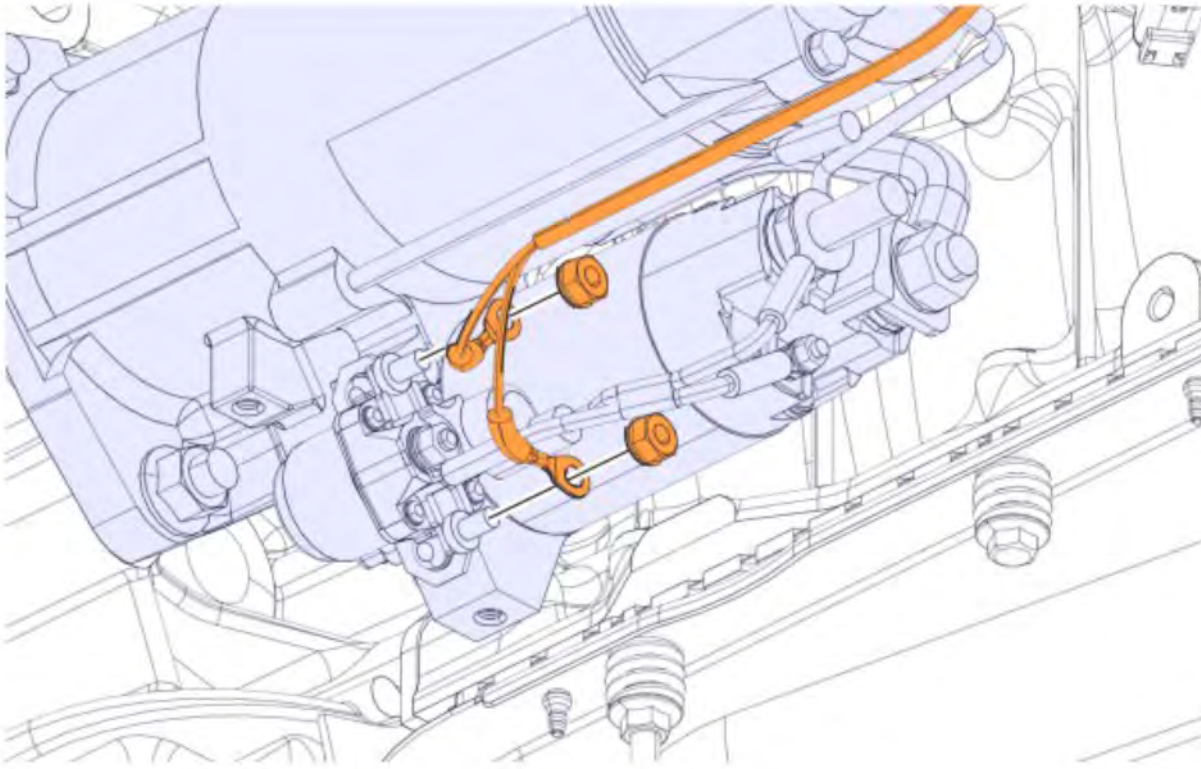

43 Remove the nuts.

44 Remove the starter motor.

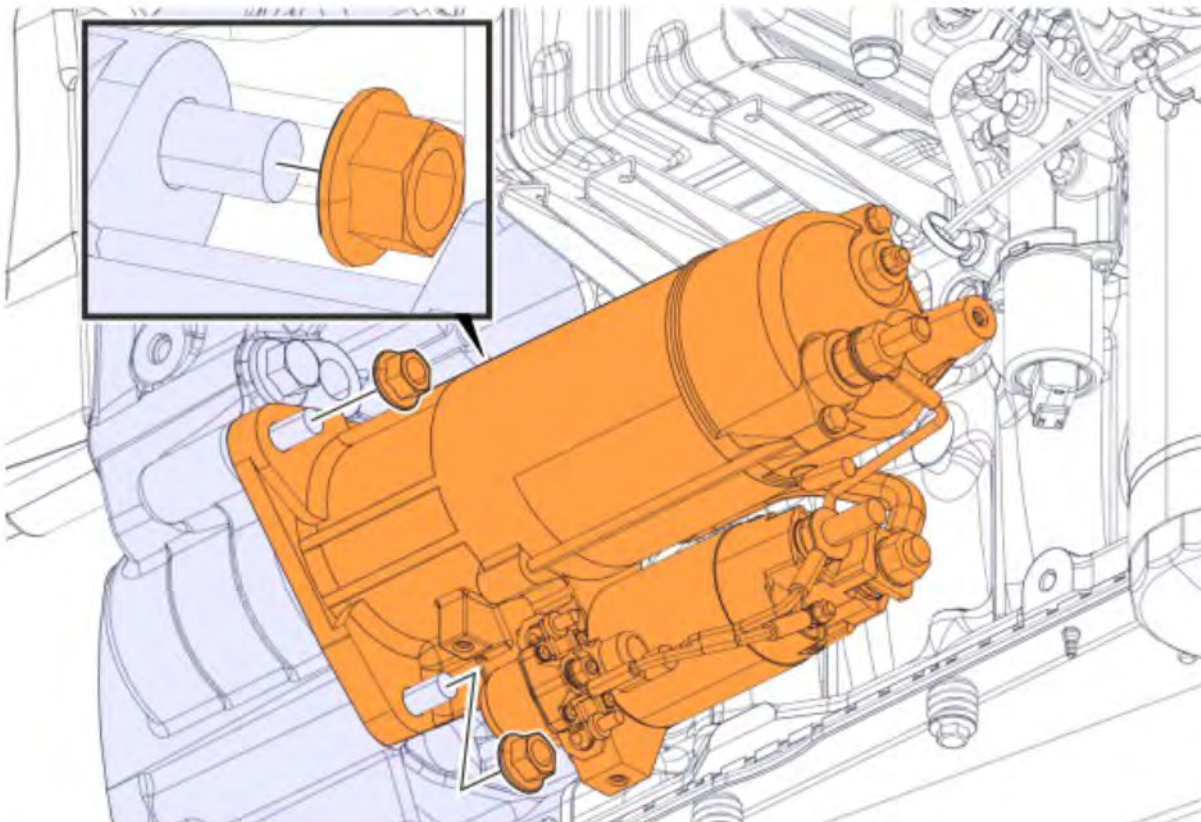

45 Remove the clamps.

i **Note**
 Note the orientations and the positions.

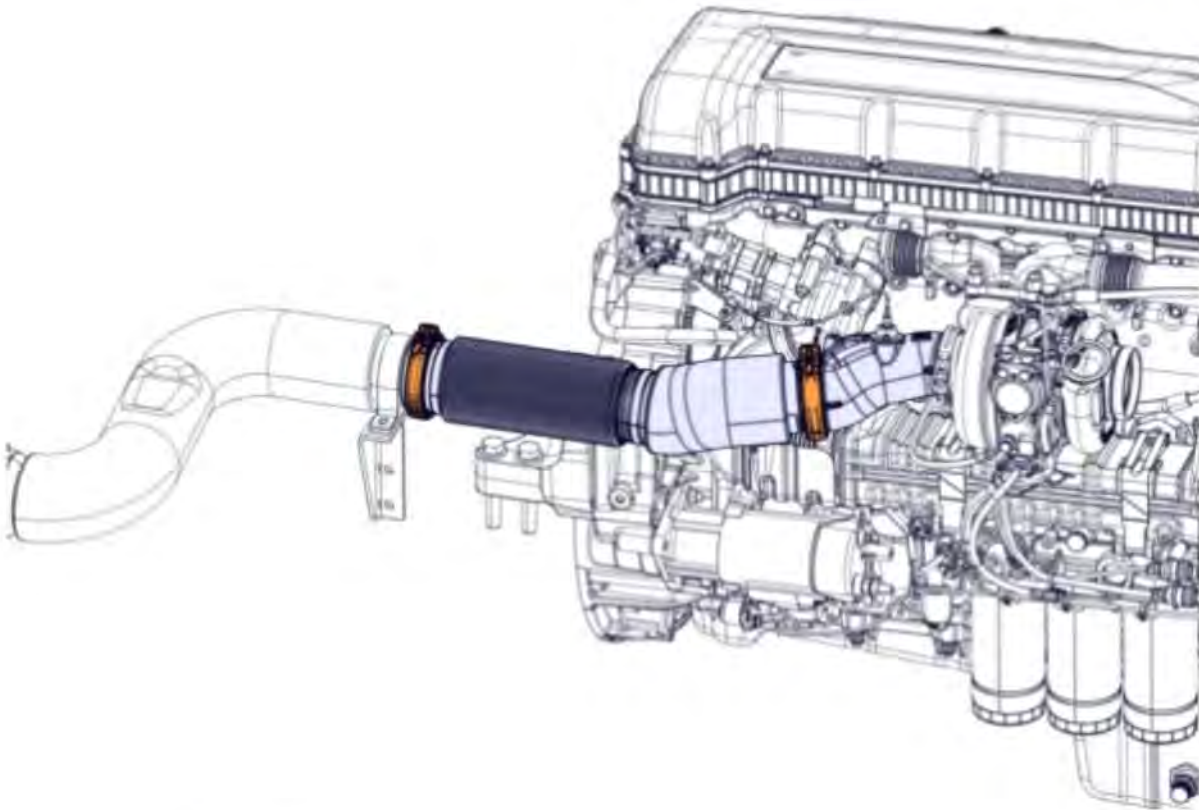

46 Remove the pipe.



Note

Note the orientation and the position.

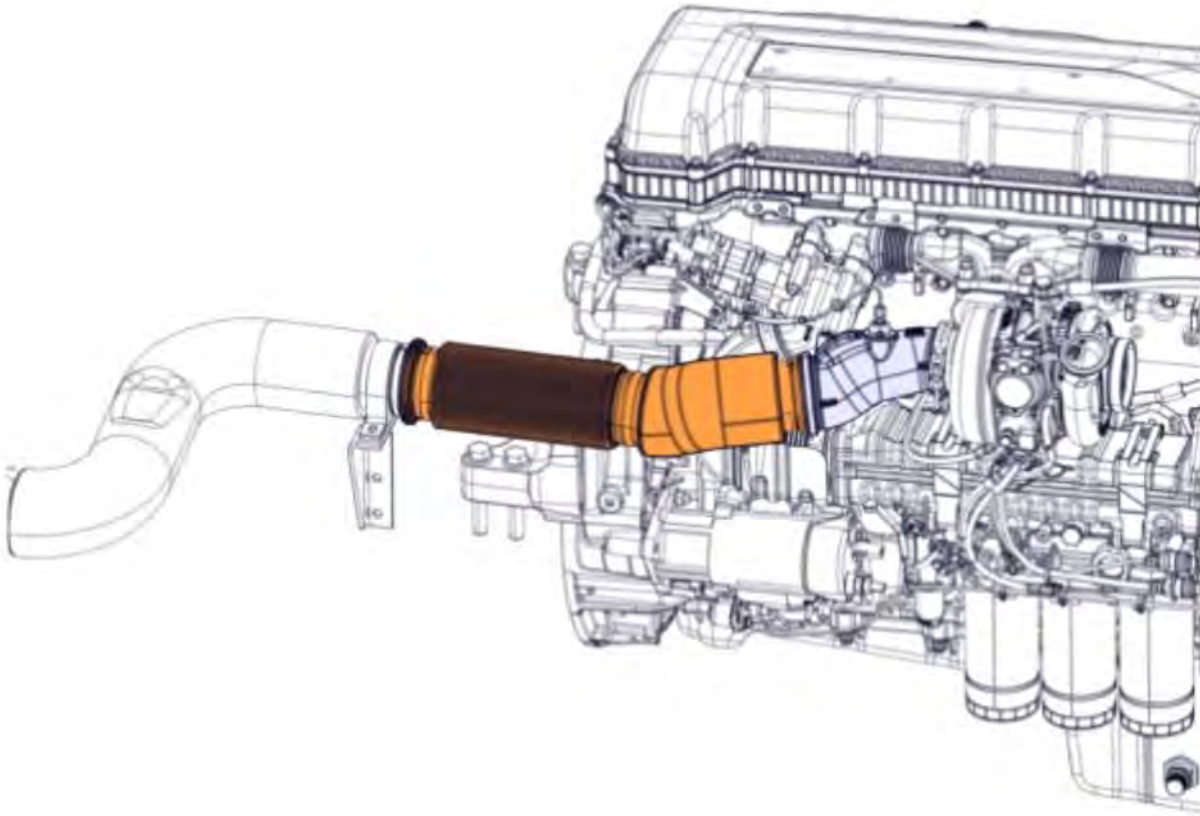

47	Remove the gaskets.
----	---------------------



48	Remove the clamp.
----	-------------------

**Note**

Note the orientation and the position.

Copyright to this documentation belongs to the Volvo Group. No reproduction, copying, change, amendment or other similar disposal is entitled without prior written consent by the Volvo Group

The information contained herein is current at the time of its original distribution, but is subject to change. The reader is advised that printed copies are uncontrolled.

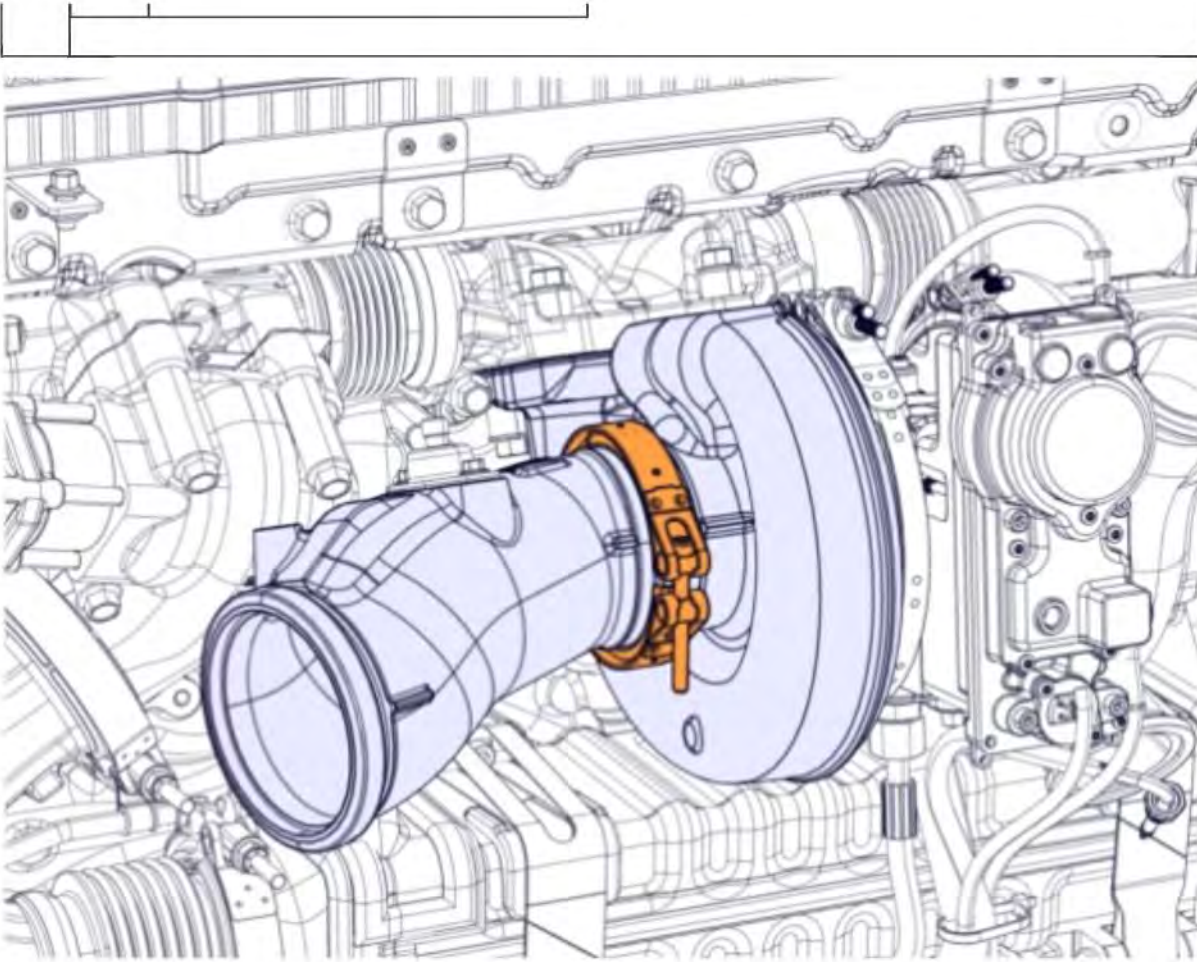

49	Remove the diffuser.
----	----------------------

50	Remove the gasket.
----	--------------------

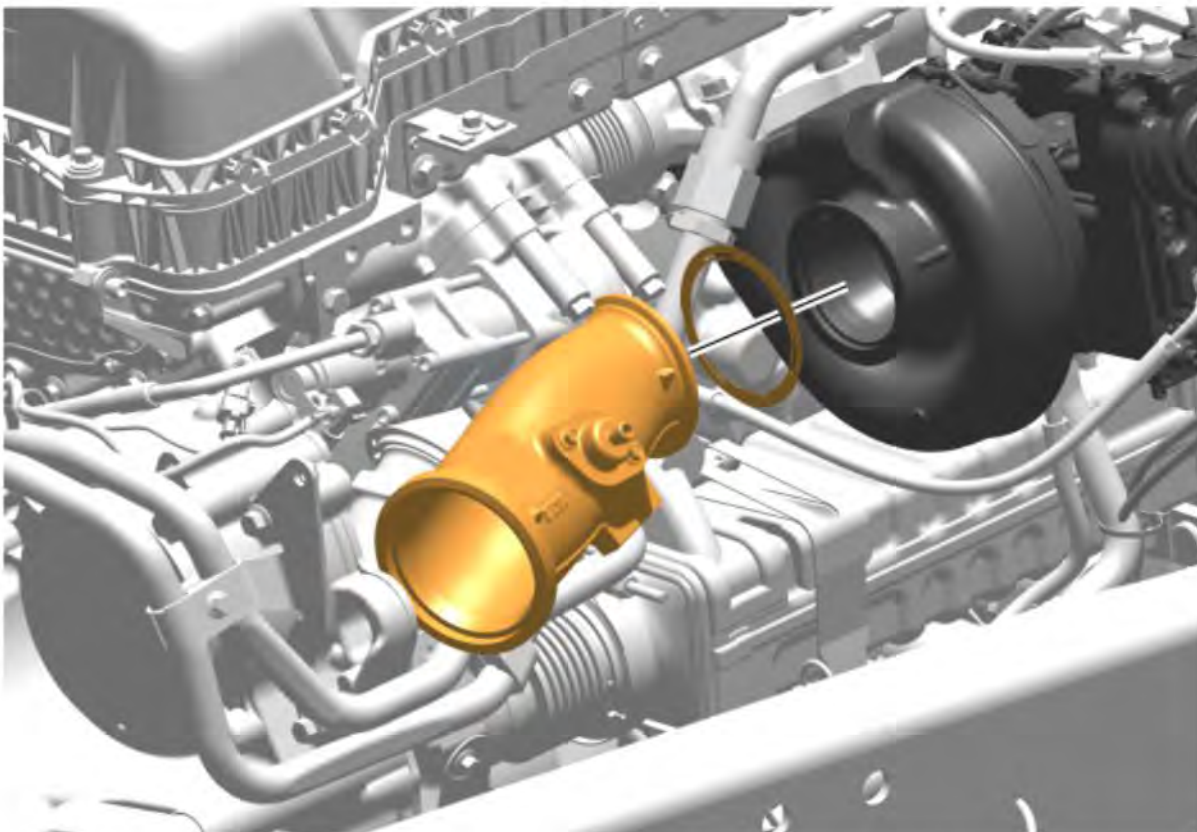

Copyright to this documentation belongs to the Volvo Group. No reproduction, copying, change, amendment or other similar disposal is entitled without prior written consent by the Volvo Group

The information contained herein is current at the time of its original distribution, but is subject to change. The reader is advised that printed copies are uncontrolled.

 WARNING	
Risk of burn injuries. Heated components and mechanical parts can cause burns.	
▶ Exercise caution when working with heated components. Always use the appropriate protective equipment.	
51	Remove the screws.
52	Remove the heat shield.

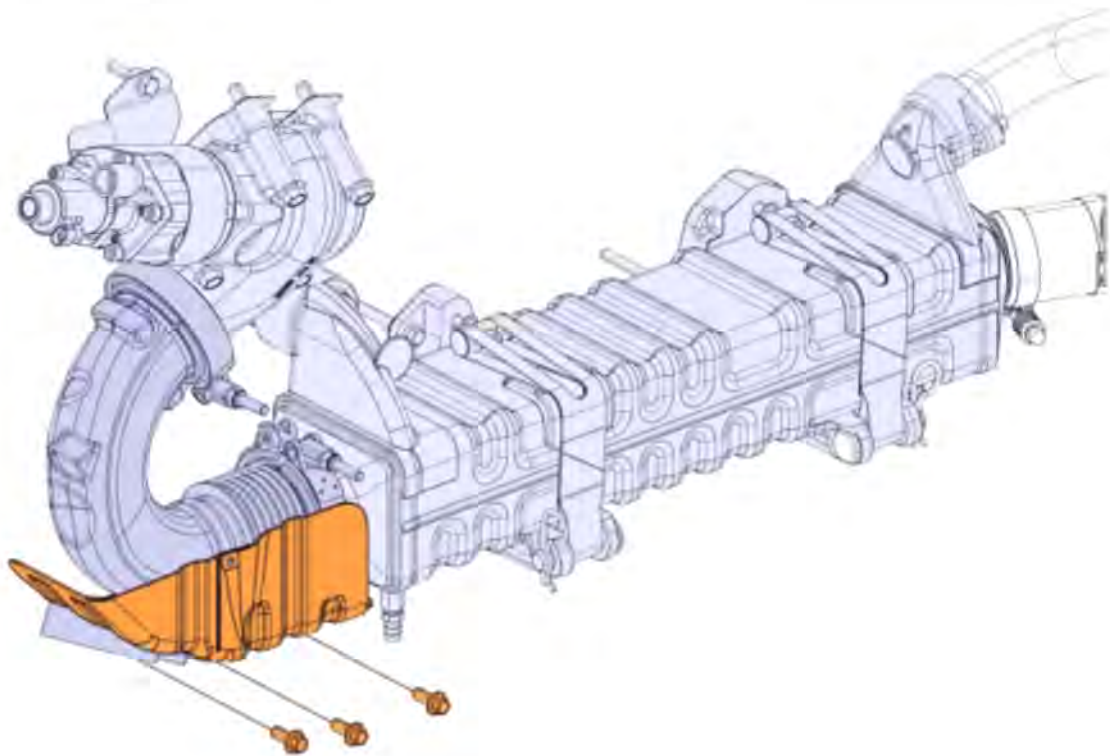

53	Remove the V-clamps.		
<table border="1" style="width: 100%;"> <tr> <td style="width: 10%; text-align: center;"></td> <td>Note Note the V-clamp positions.</td> </tr> </table>			Note Note the V-clamp positions.
	Note Note the V-clamp positions.		

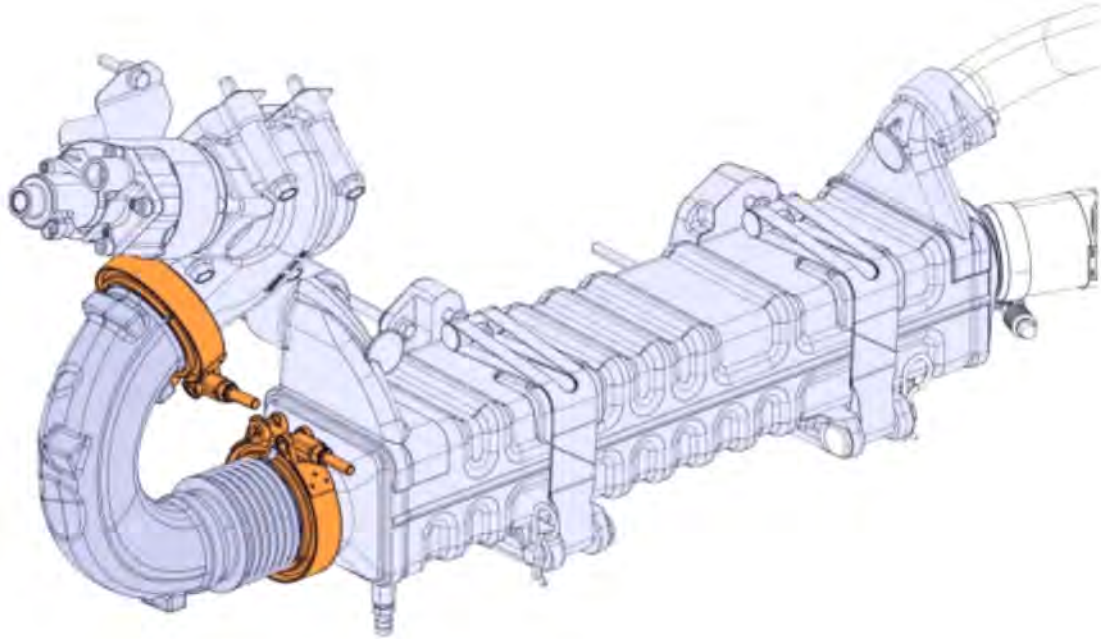

54	Remove the pipe.
----	------------------

55	Remove the gaskets.
----	---------------------

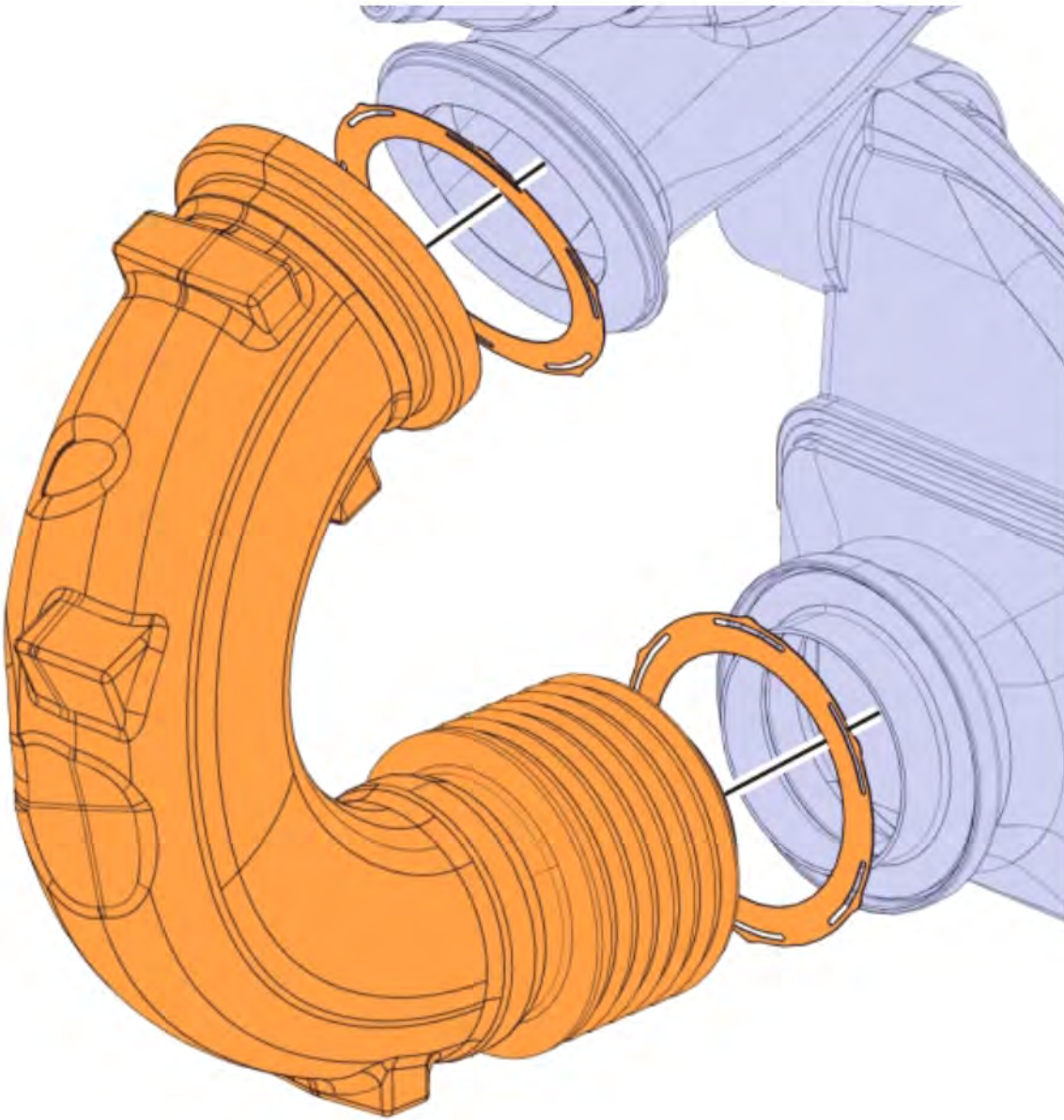

56	Remove the cable ties.
----	------------------------

57	Disconnect the connector.
----	---------------------------

58	Move the cable aside.
----	-----------------------

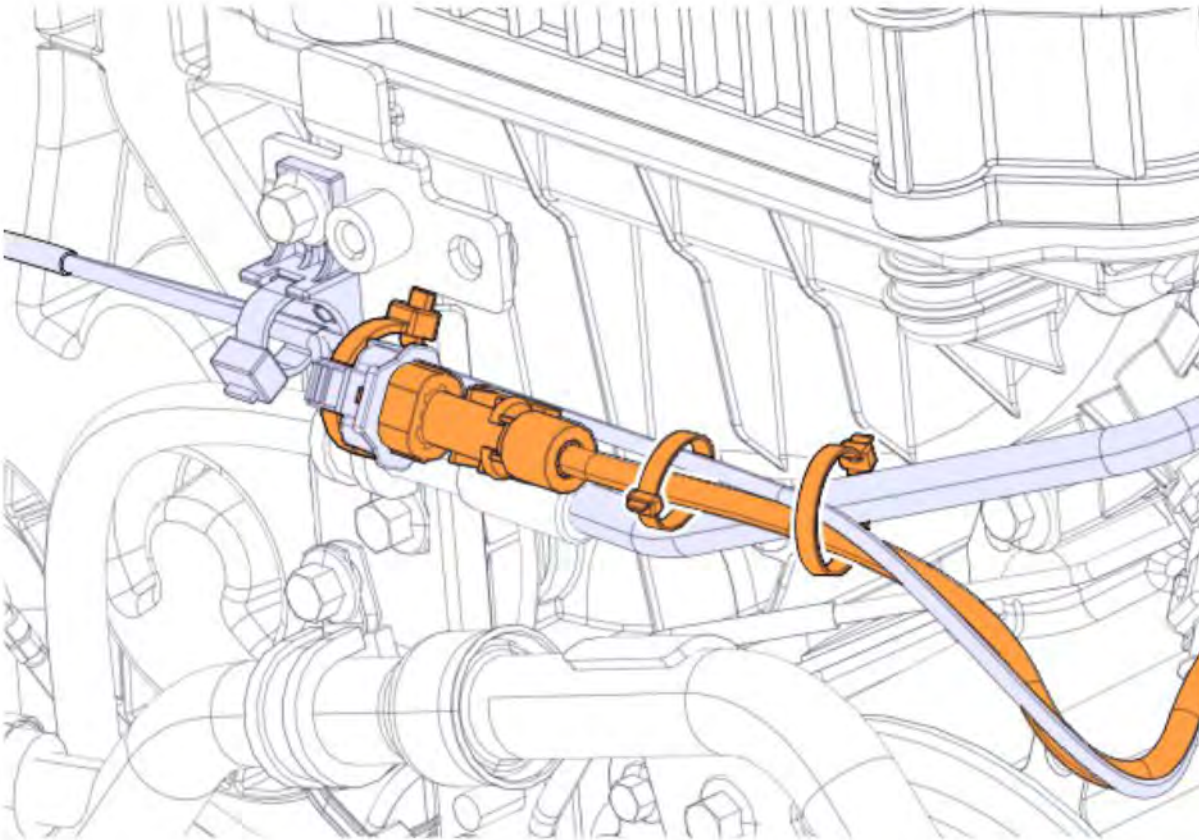

59 Loosen the pipe.

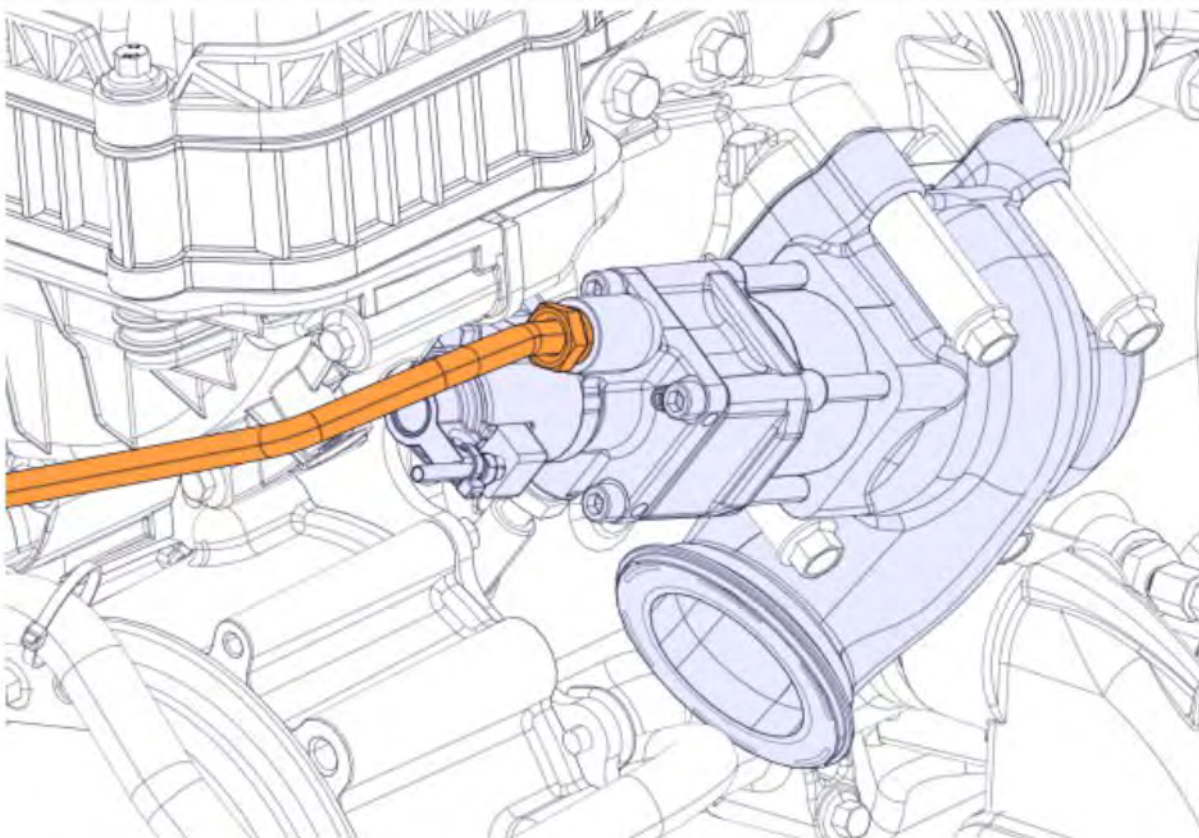

60 Loosen the screws.

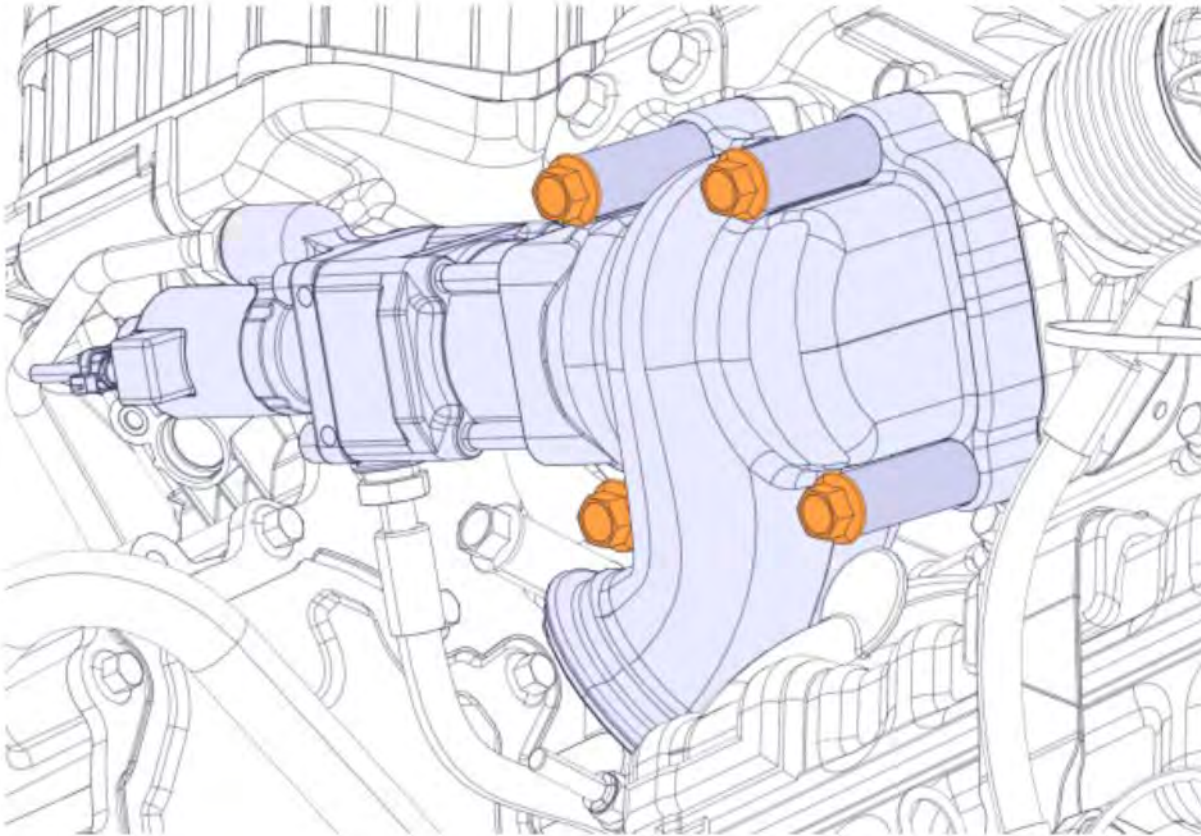

61	Loosen the pipe.
----	------------------

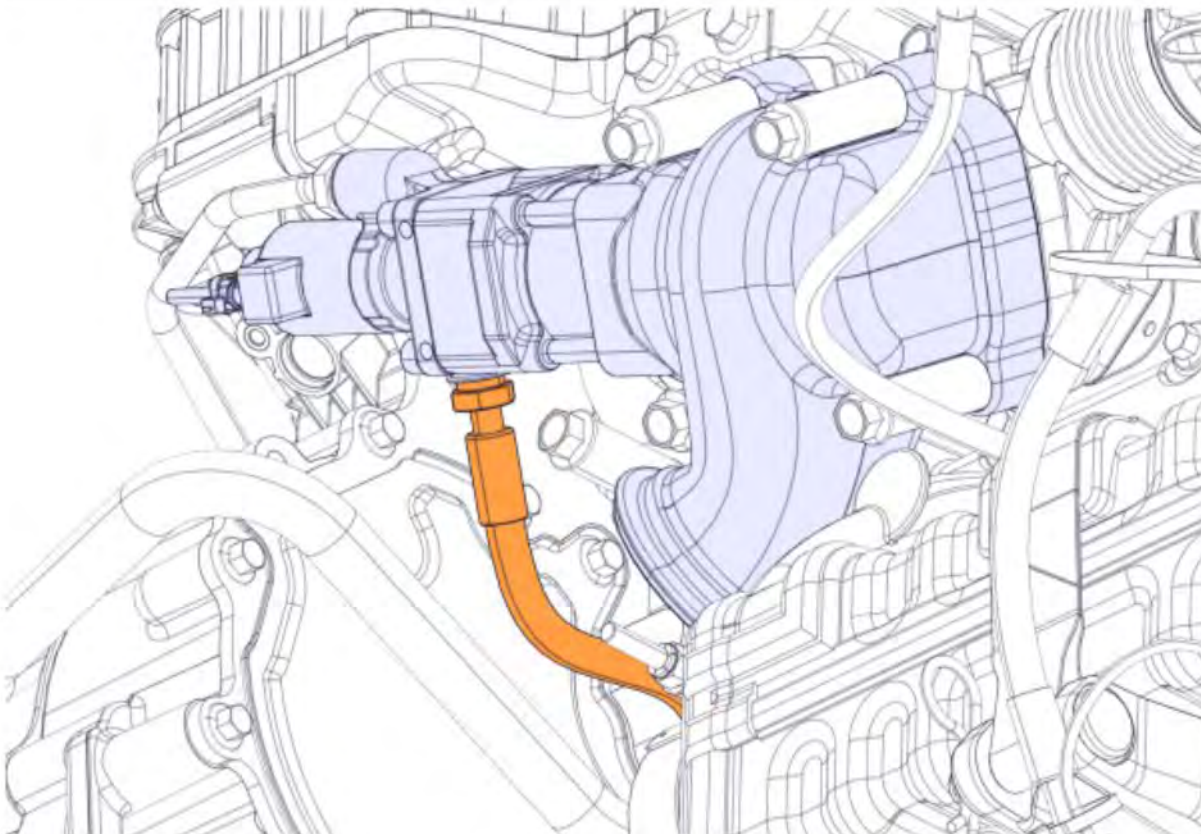

62	Remove the screws.
----	--------------------

63	Remove the spacers.
----	---------------------

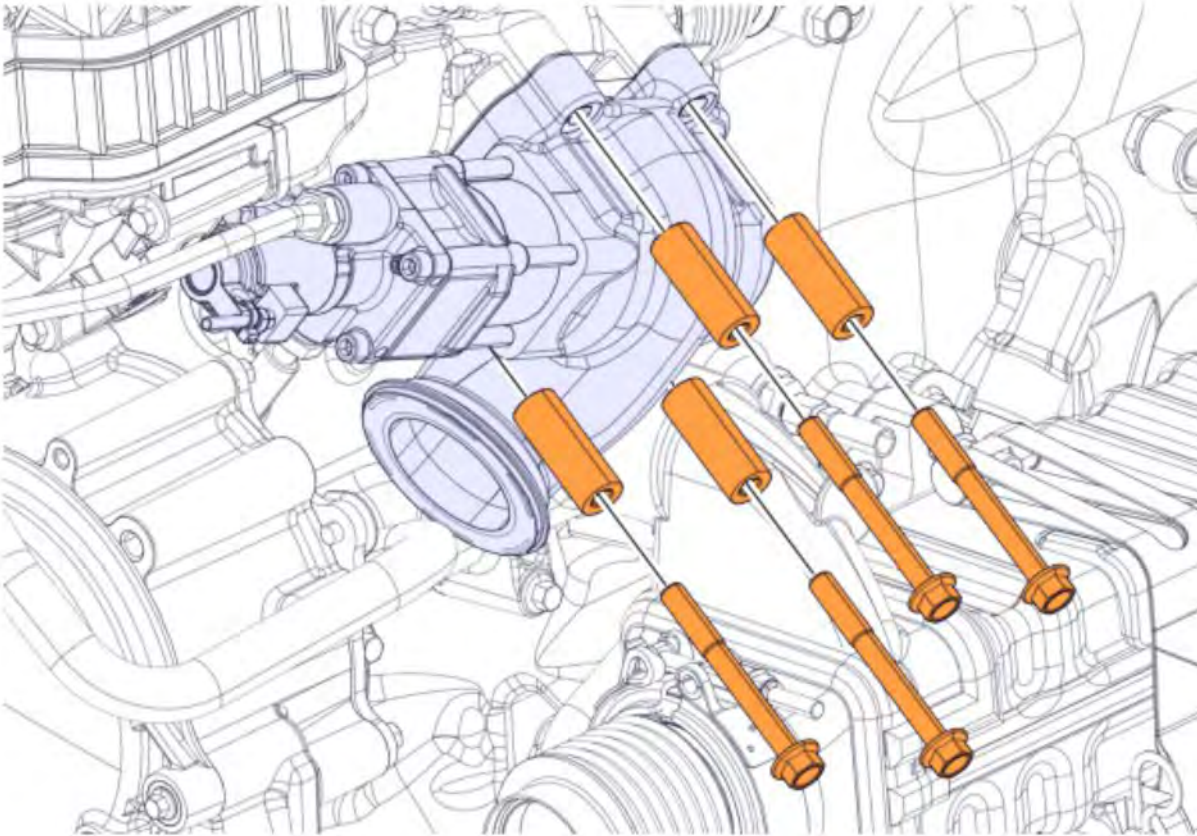

64	Remove the pipes.
----	-------------------

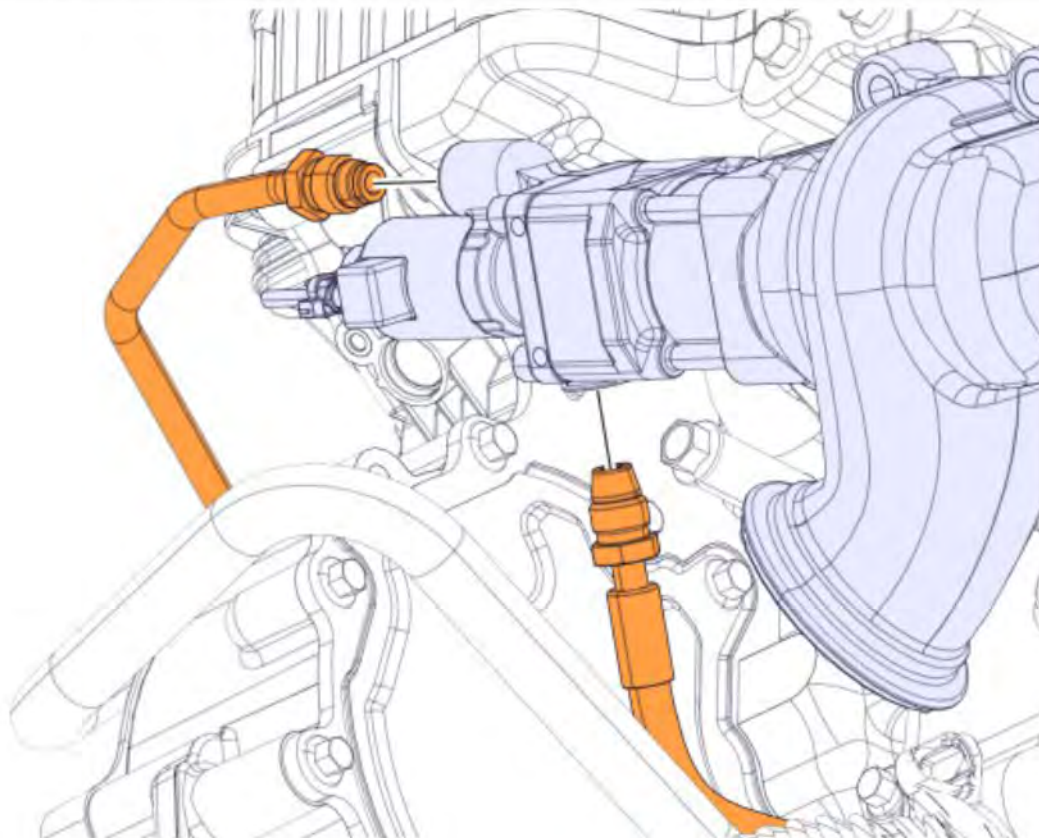

65	Remove the valve.
----	-------------------

66	Remove the gasket.
----	--------------------

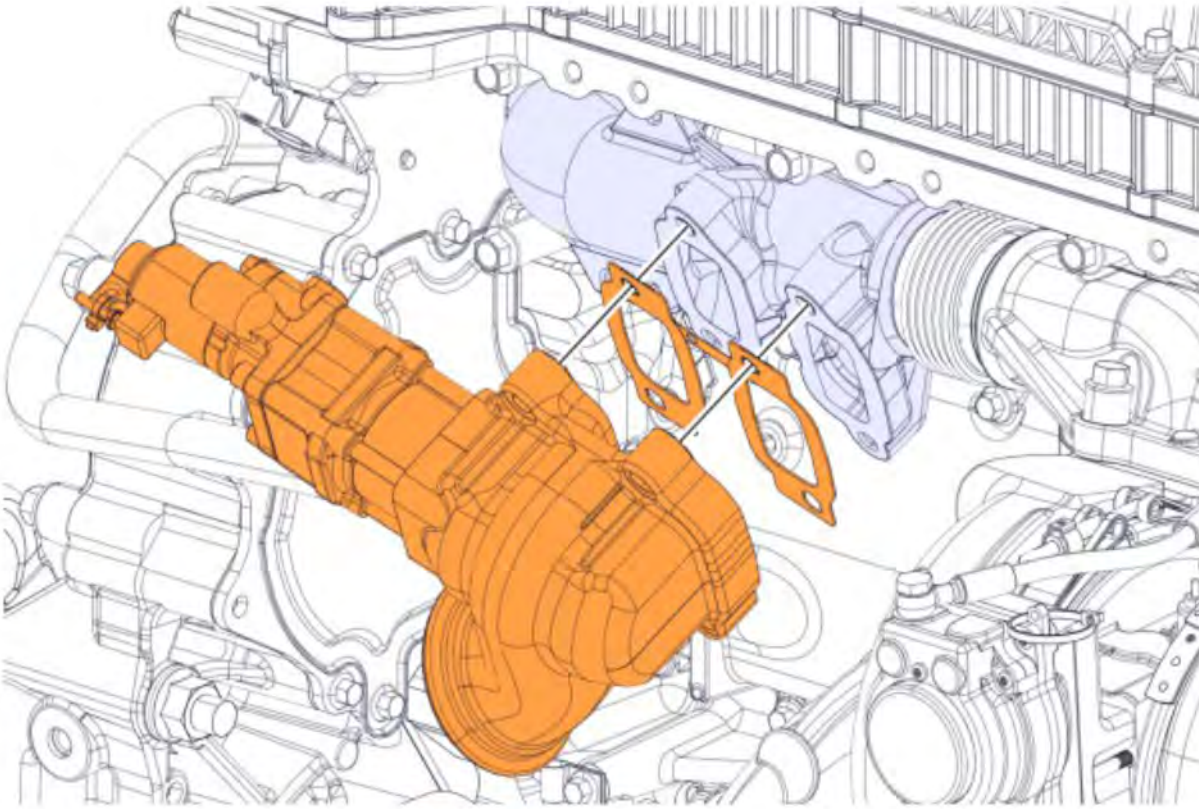

67	Remove the seal.
----	------------------

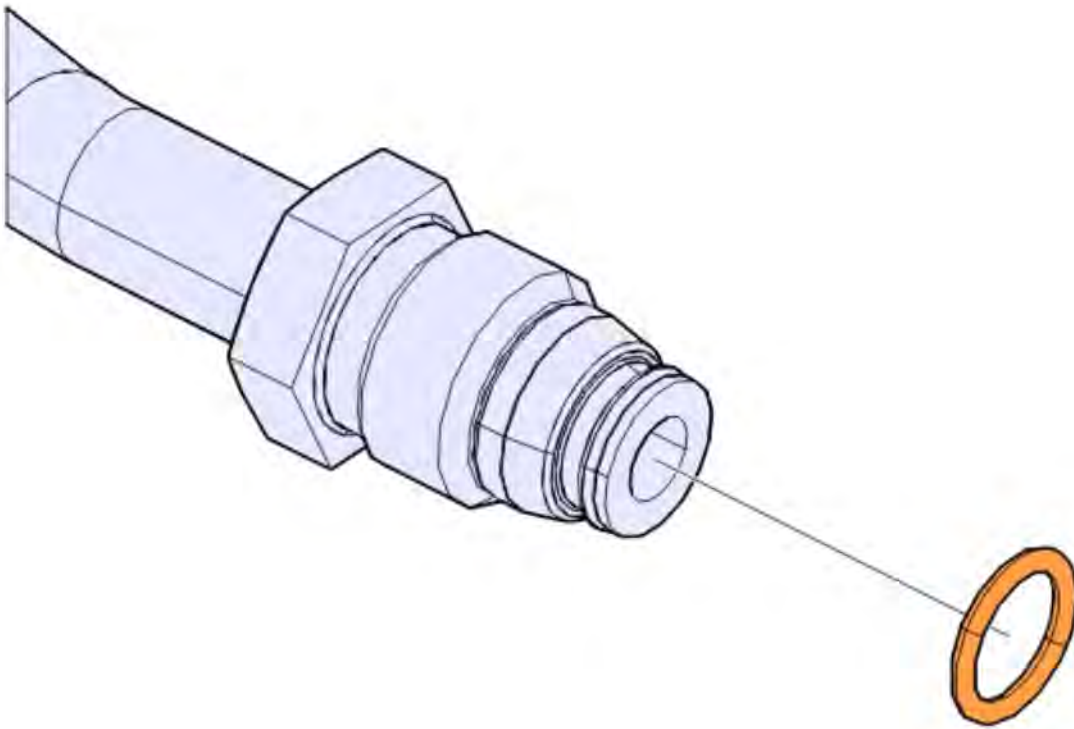

68	Loosen the nut.
----	-----------------

69	Remove the hose.
----	------------------

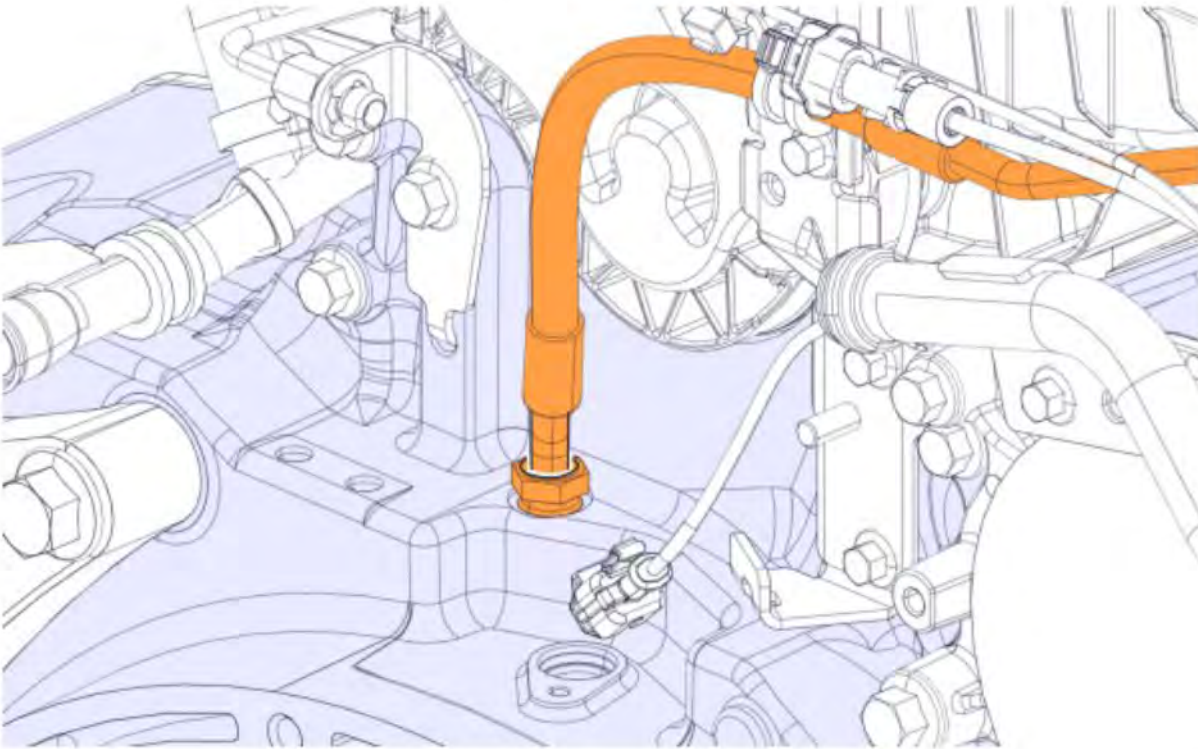

70	Remove the cable ties.
----	------------------------

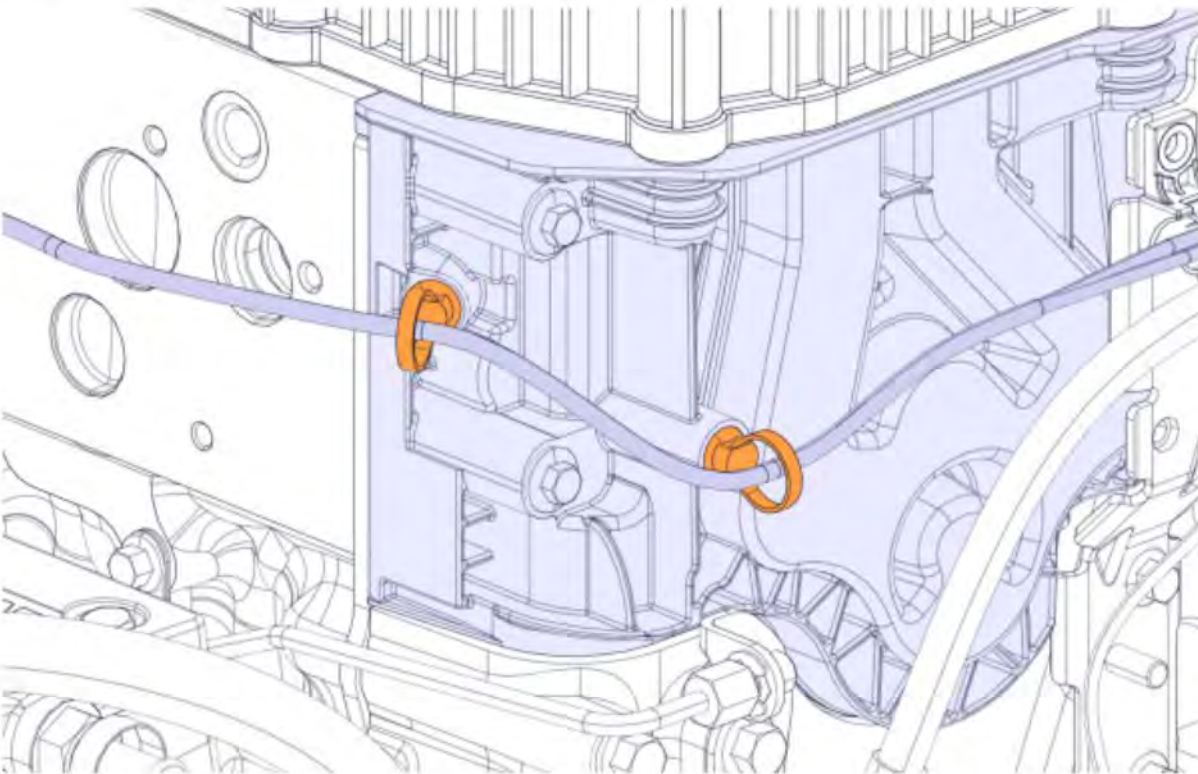

71	Remove the screws.
----	--------------------

72	Move the assembly aside.
----	--------------------------

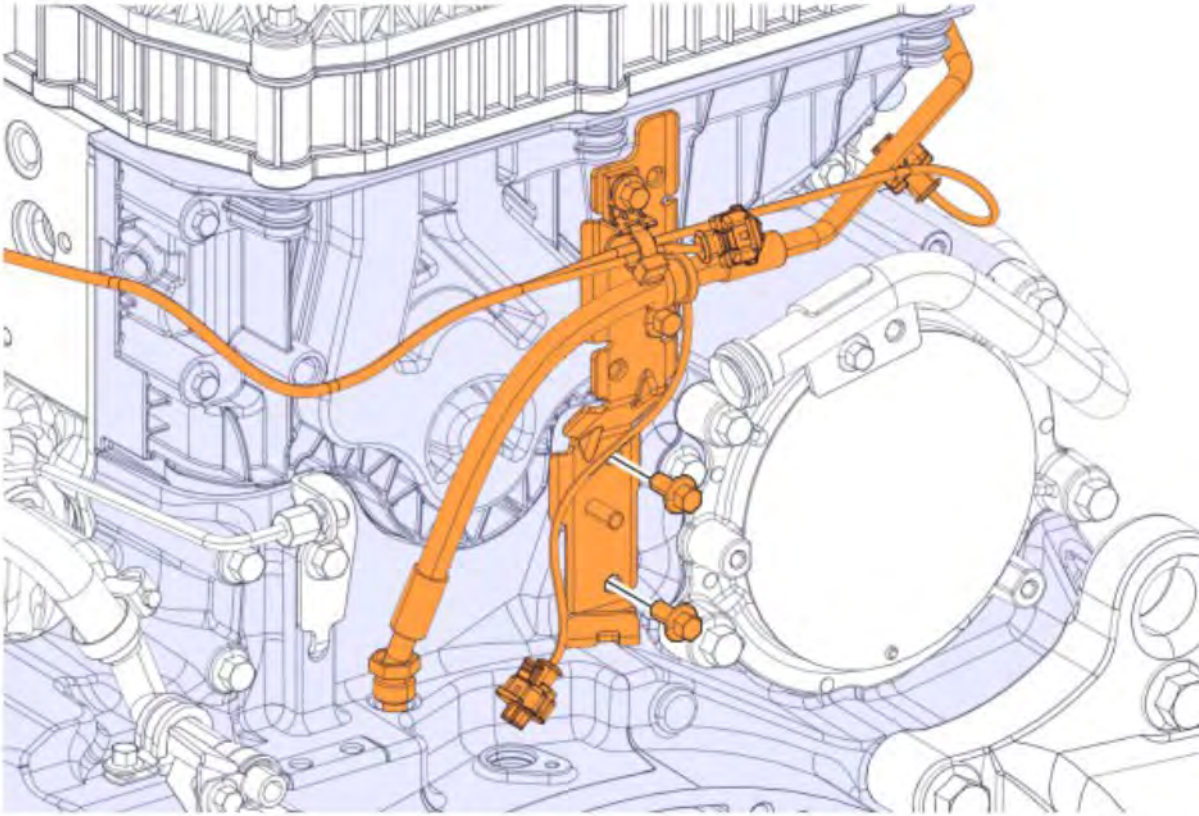

73	Remove the screw.
-----------	-------------------

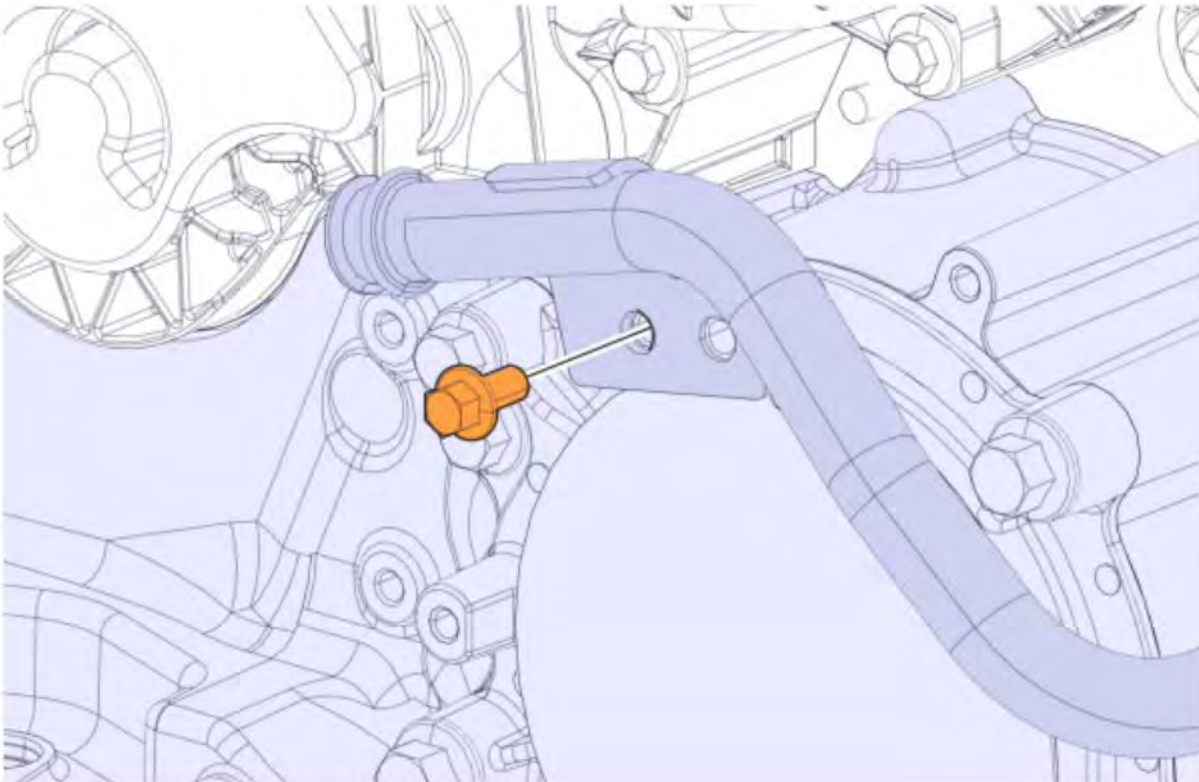

74	Remove the screws.
-----------	--------------------

75	Remove the clamp.
-----------	-------------------

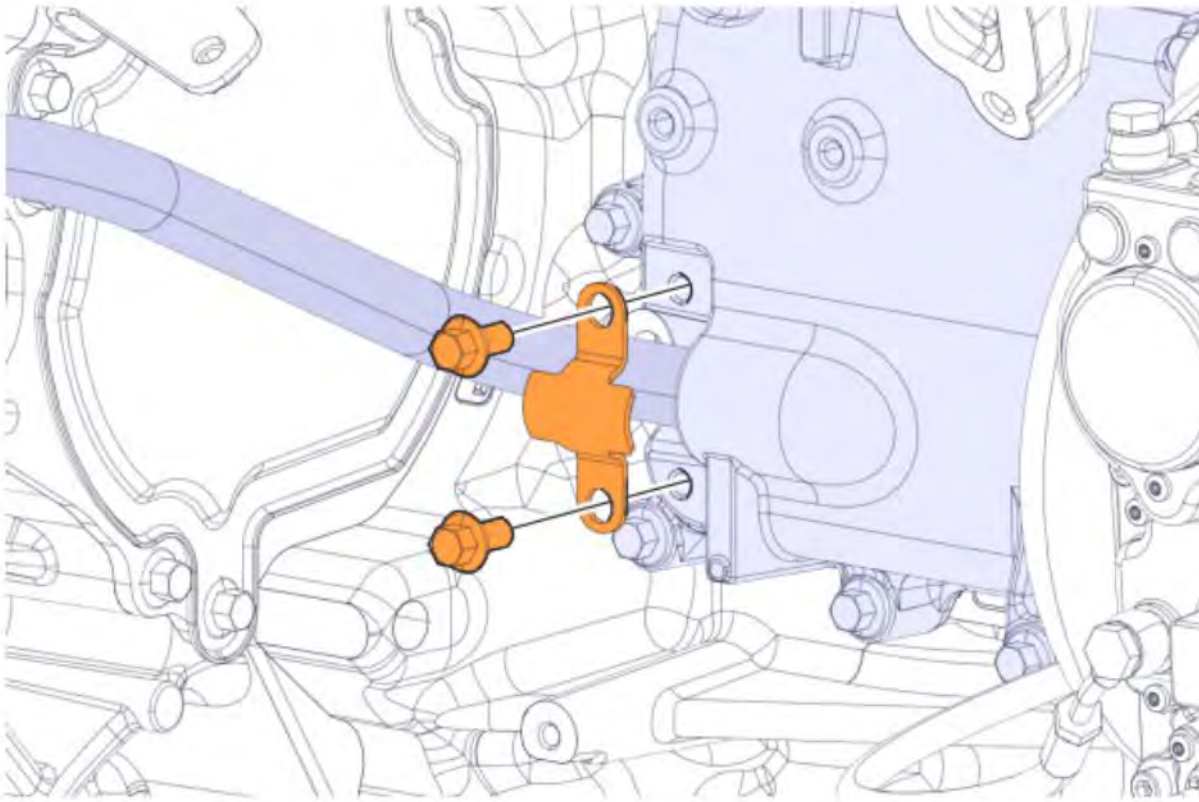

76	Remove the pipe.
-----------	------------------

77	Remove the seal.
-----------	------------------

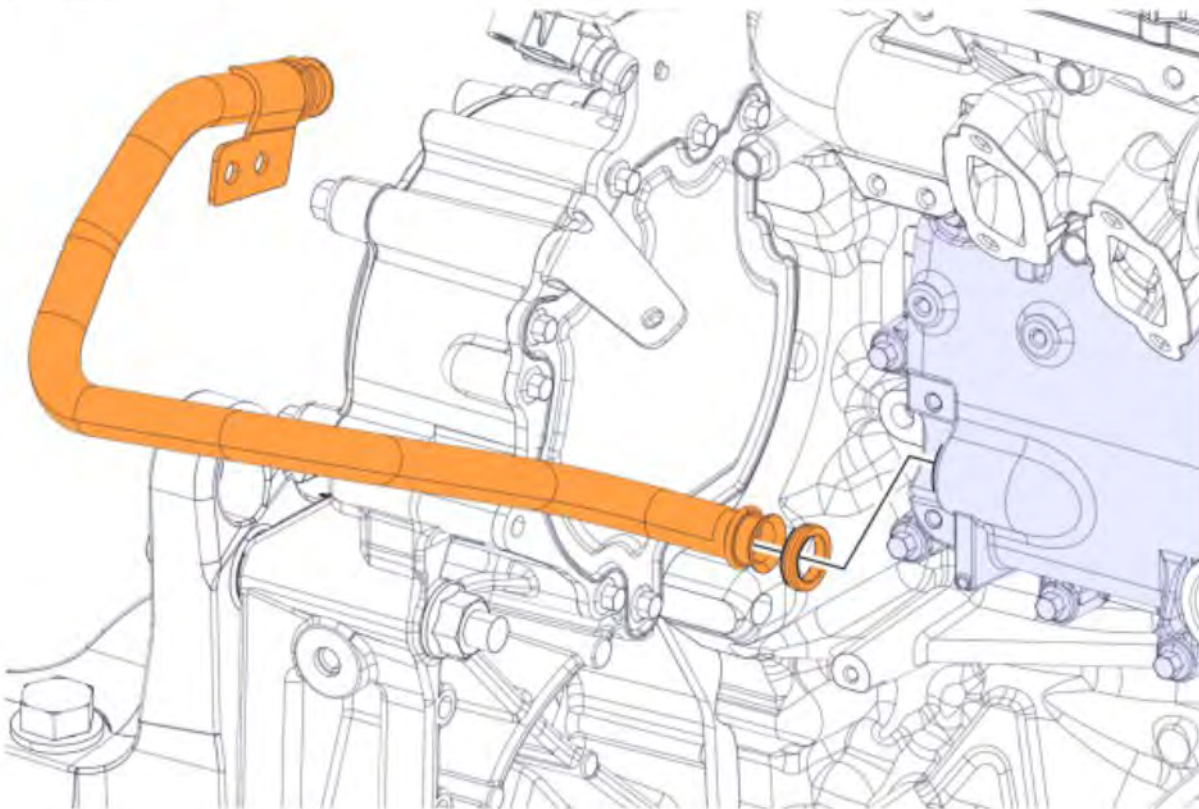

78	Remove the screws.
-----------	--------------------

79	Remove the pump.
-----------	------------------

Note

Copyright to this documentation belongs to the Volvo Group. No reproduction, copying, change, amendment or other similar disposal is entitled without prior written consent by the Volvo Group

The information contained herein is current at the time of its original distribution, but is subject to change. The reader is advised that printed copies are uncontrolled.

i	Leave the pipes connected to the pump.
i	<p>Note Support the pump.</p>

80 Remove the seal.

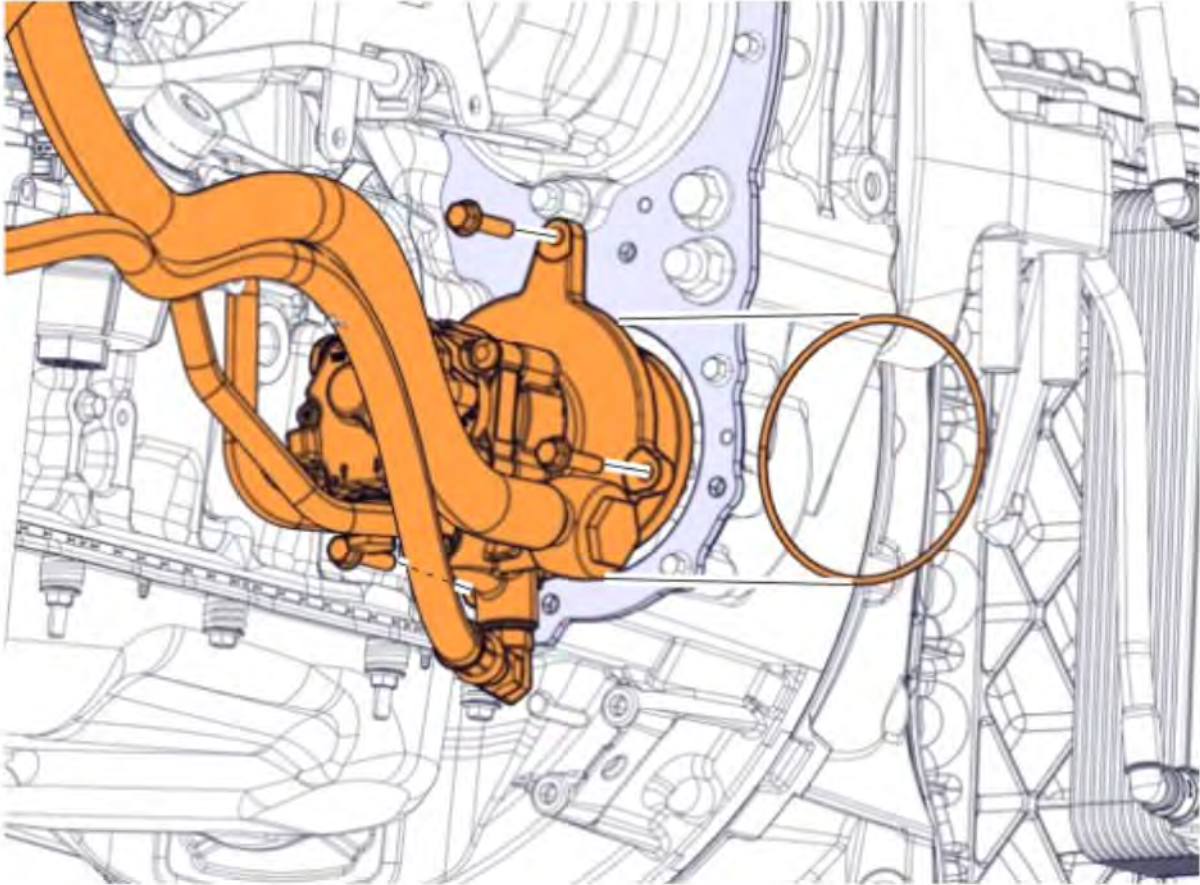

81	Remove the cable ties.
i	<p>Note Note the positions.</p>

82 Disconnect the connector.

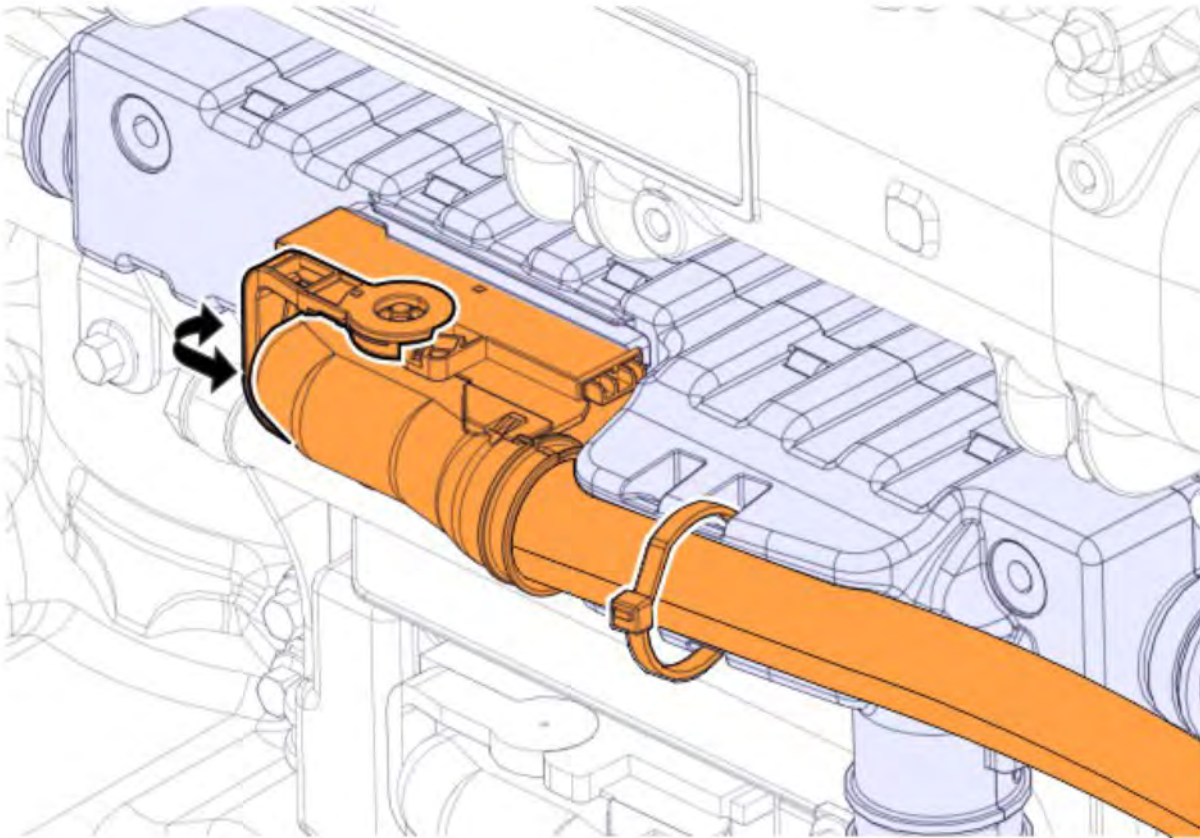

83	Disconnect the air line.	
	Required material	
	DISASSEMBLY TOOL	J-44773

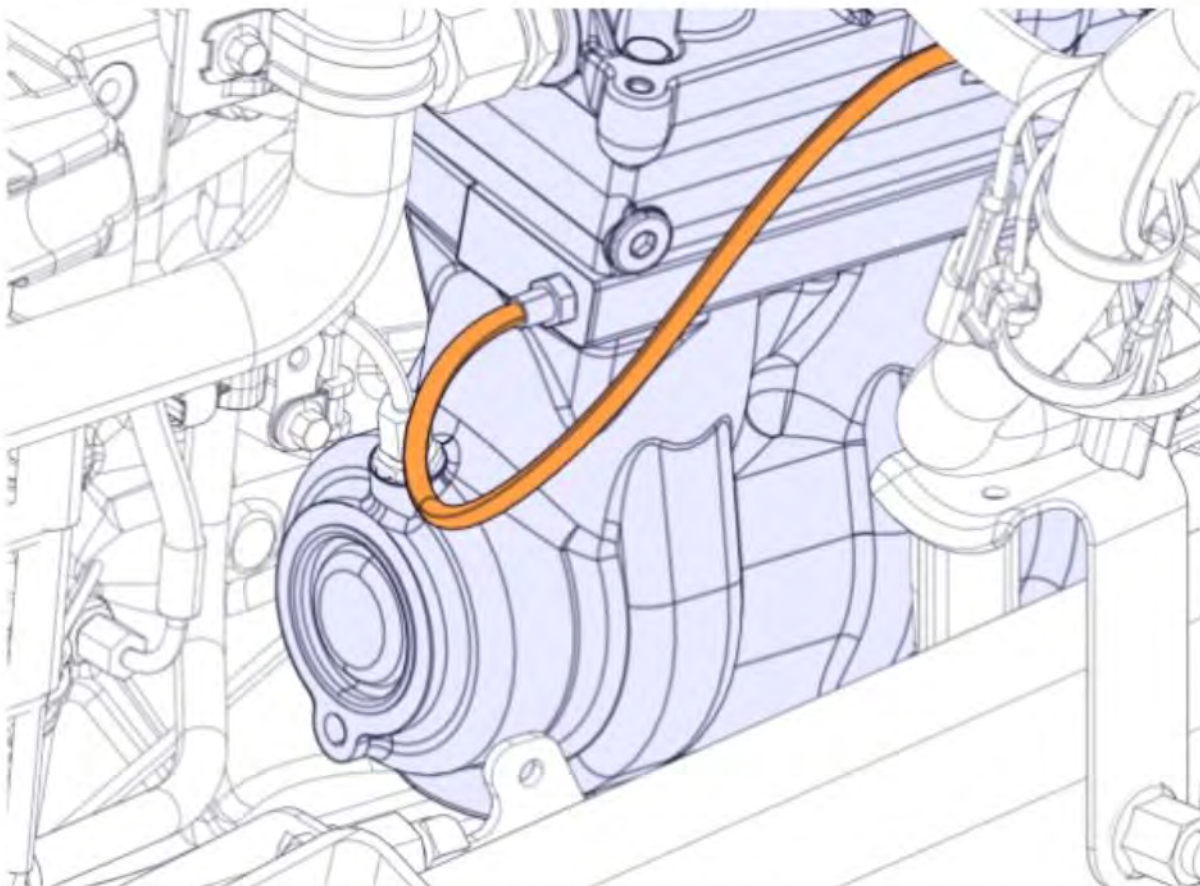

Copyright to this documentation belongs to the Volvo Group. No reproduction, copying, change, amendment or other similar disposal is entitled without prior written consent by the Volvo Group

The information contained herein is current at the time of its original distribution, but is subject to change. The reader is advised that printed copies are uncontrolled.

84	Remove the oil hose.
----	----------------------

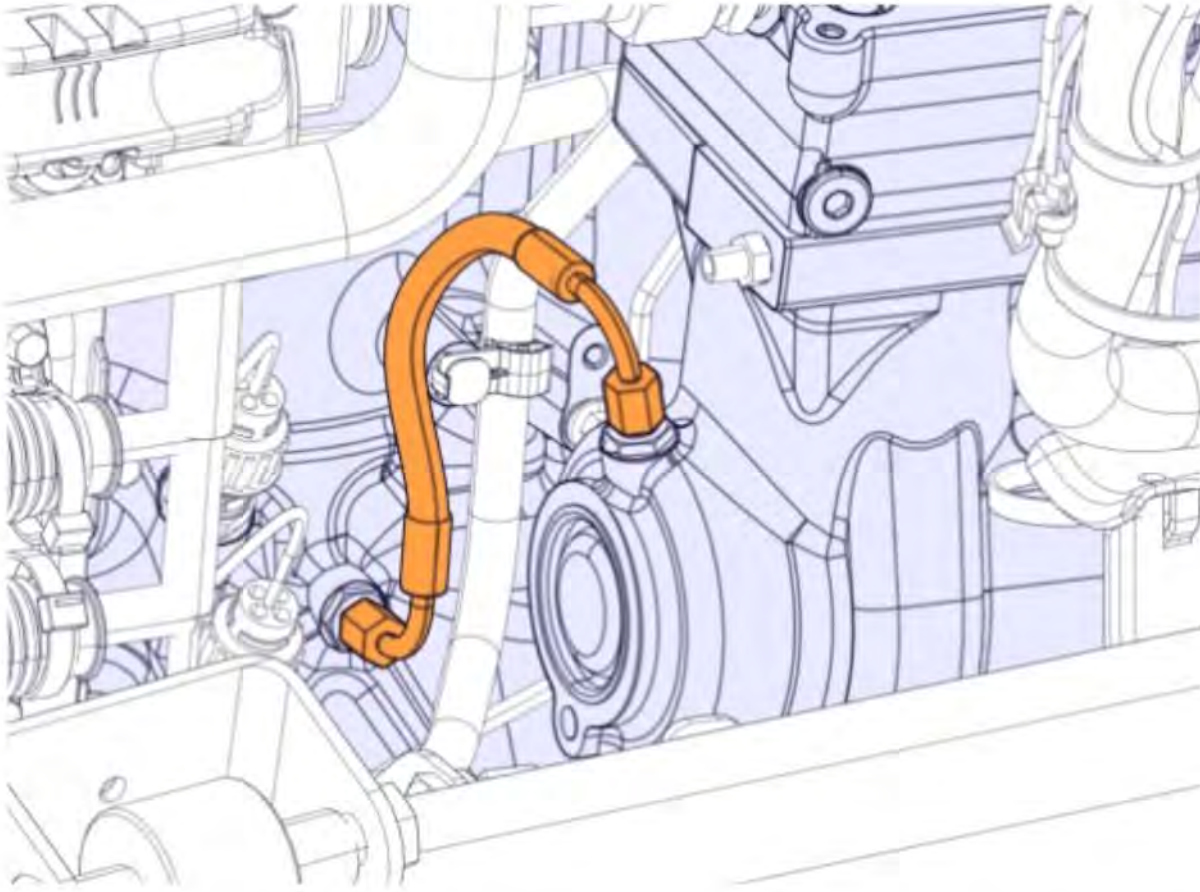

85	Loosen the nut.
----	-----------------

86	Remove the pipe.
----	------------------

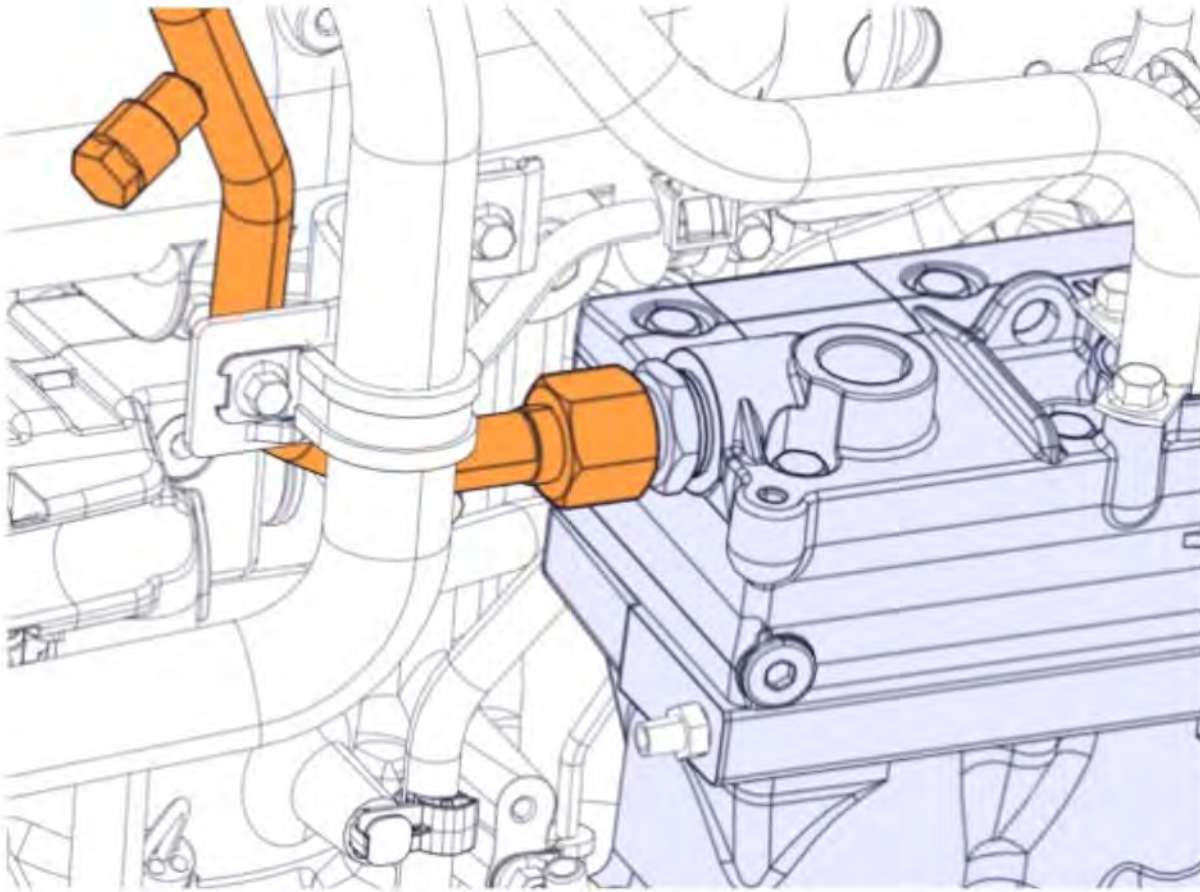

87	Remove the screws.
88	Remove the lock braces.
89	Move aside the pipe.
90	Remove the sealing ring.

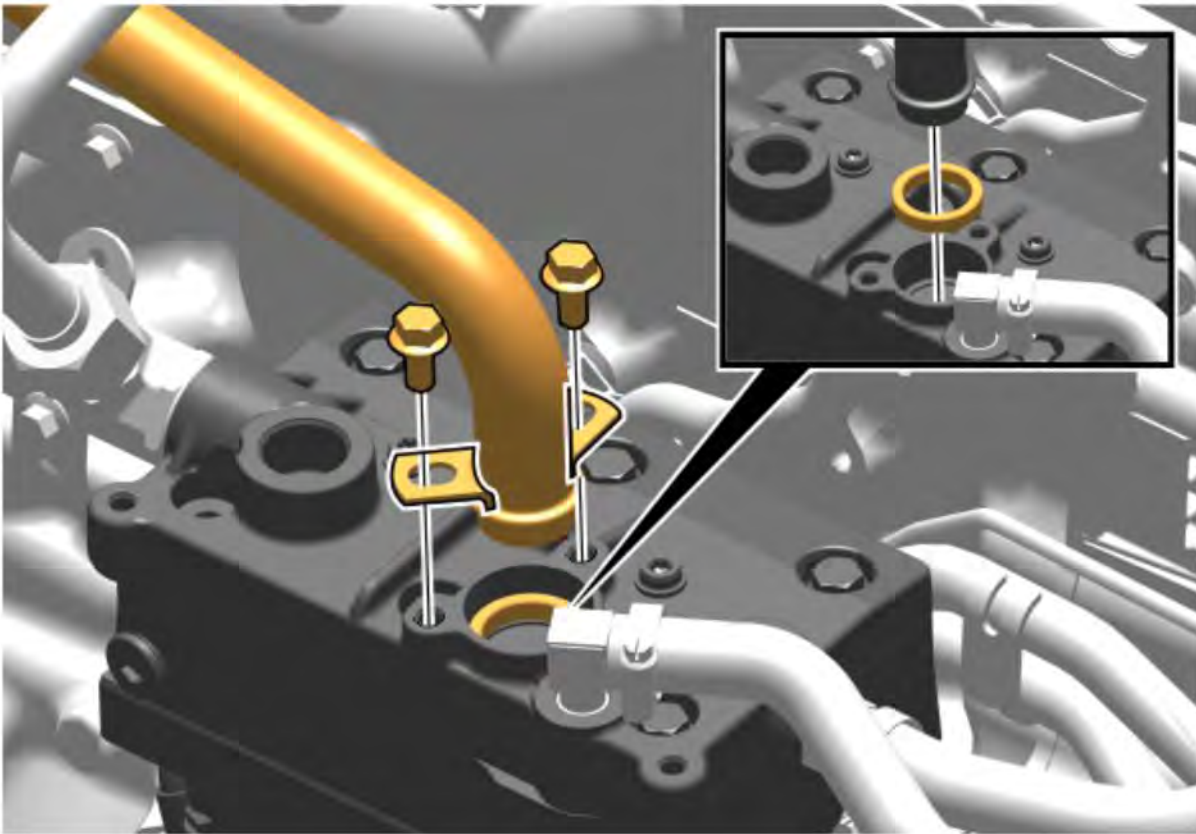

91	Loosen the clamps.
-----------	--------------------

92	Remove the hoses.
-----------	-------------------

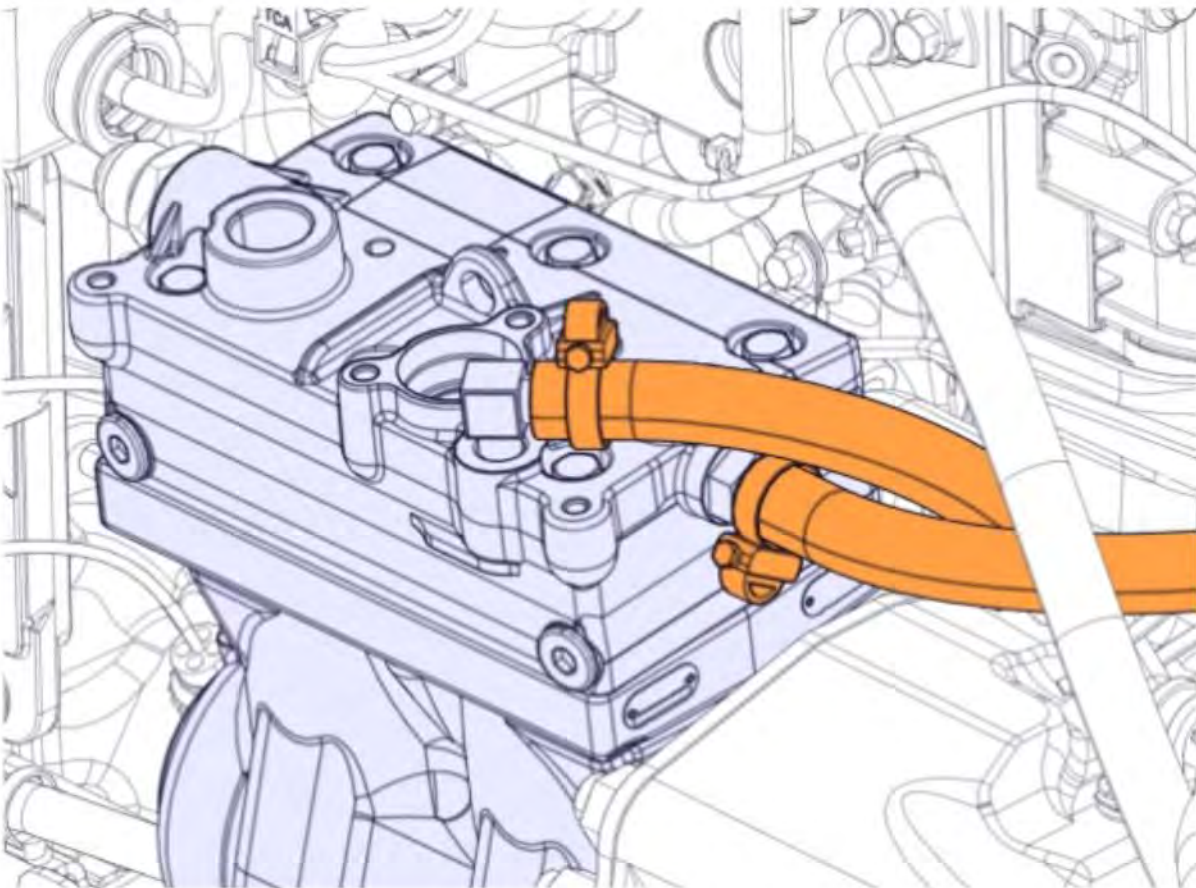

93	Remove the nuts.
-----------	------------------

Copyright to this documentation belongs to the Volvo Group. No reproduction, copying, change, amendment or other similar disposal is entitled without prior written consent by the Volvo Group

The information contained herein is current at the time of its original distribution, but is subject to change. The reader is advised that printed copies are uncontrolled.

**CAUTION****Risk of serious injury.**

Heavy component.

► Exercise caution when moving the component. Use appropriate tools.

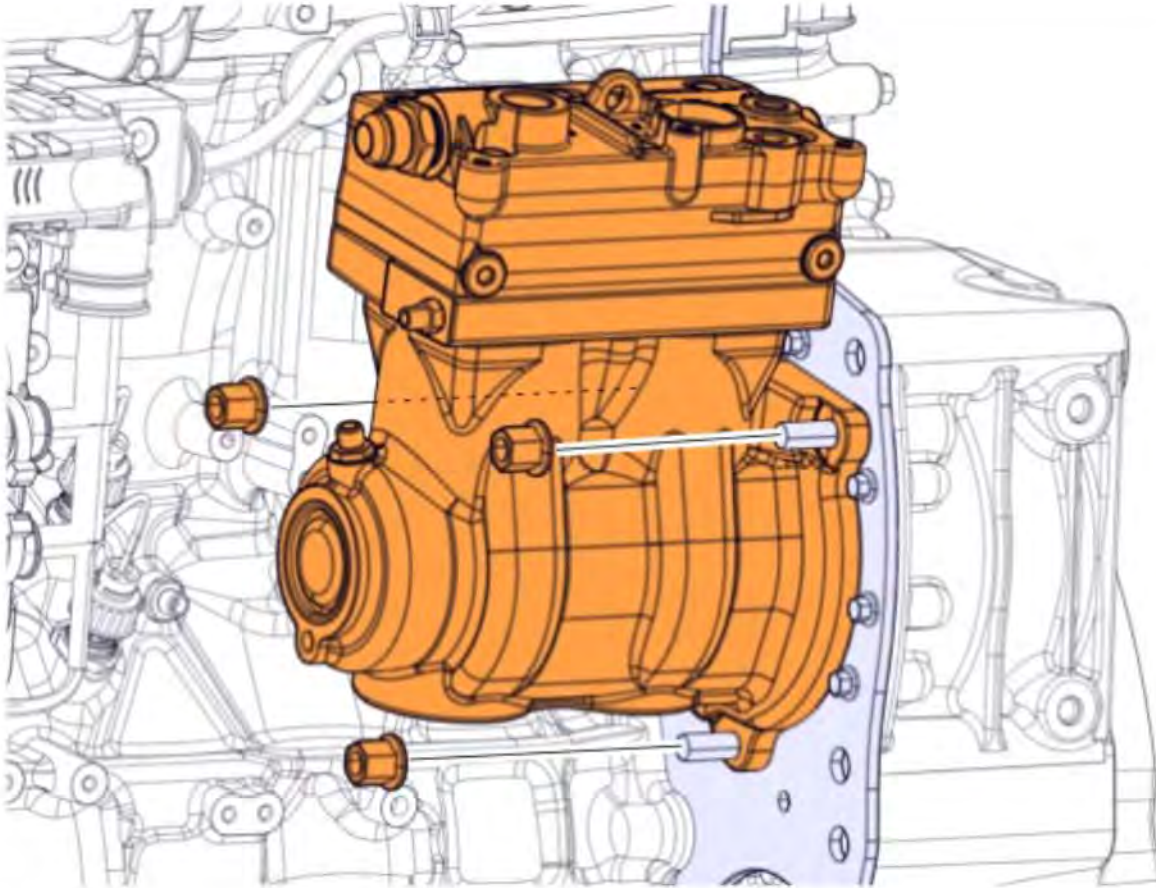
94 Remove the compressor.**95** Remove the O-ring.



96	Remove the screw.
-----------	-------------------

97	Move aside the pipe.
-----------	----------------------

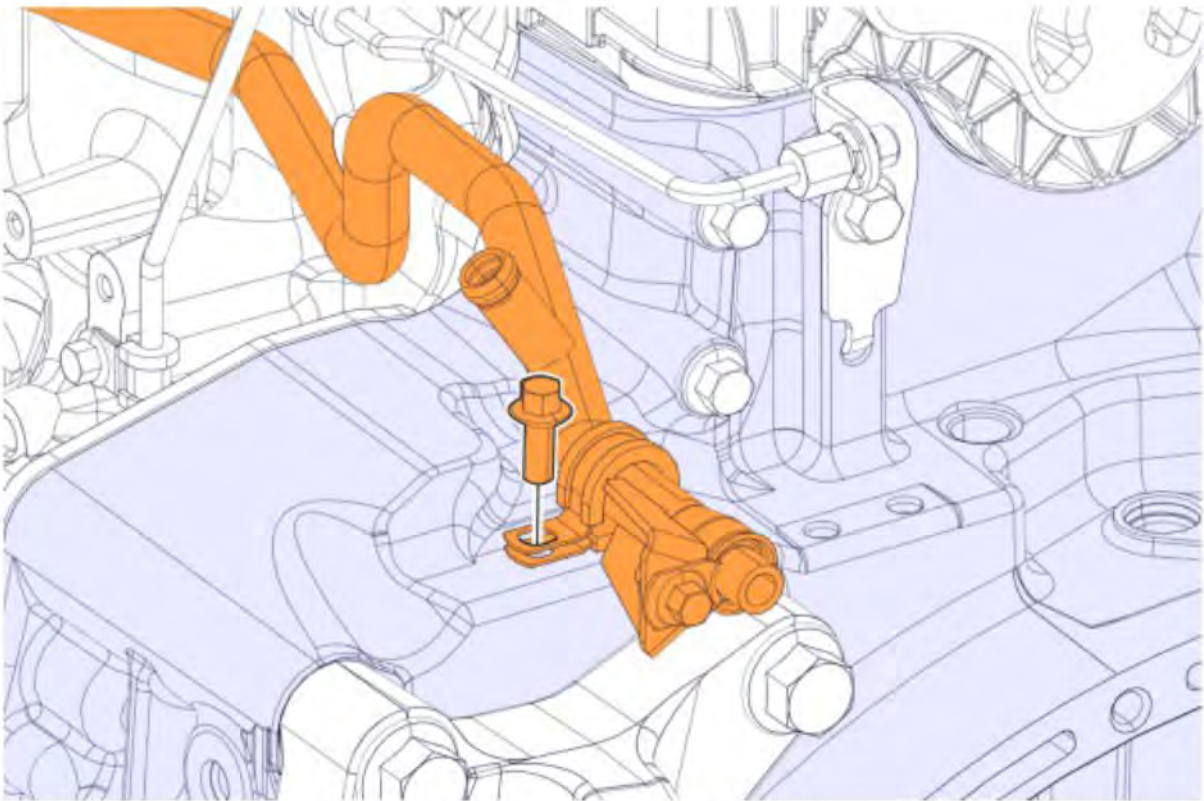

98	Remove the screws.
-----------	--------------------

99	Remove the clamps.
-----------	--------------------



100	Loosen the nut.
-----	-----------------

101	Remove the pipe.
-----	------------------

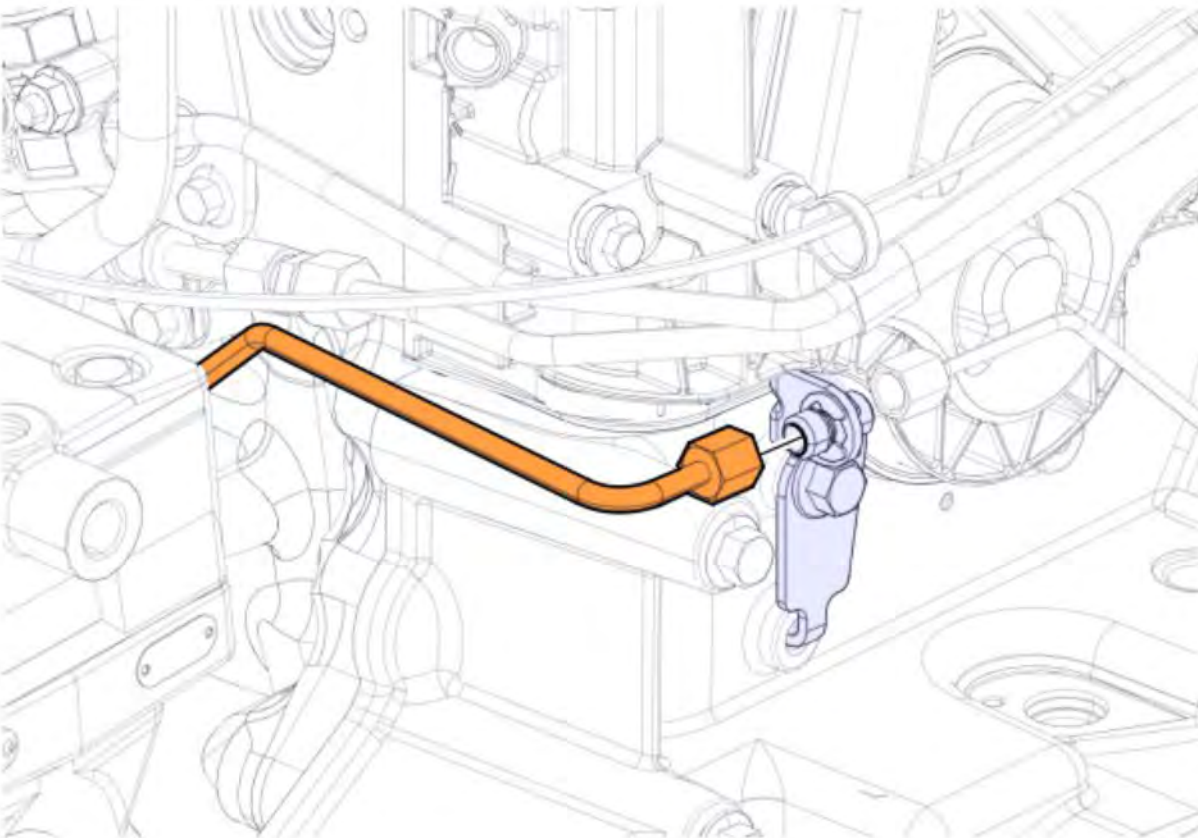

102	Remove the screw.
-----	-------------------

103	Remove the bracket.
-----	---------------------

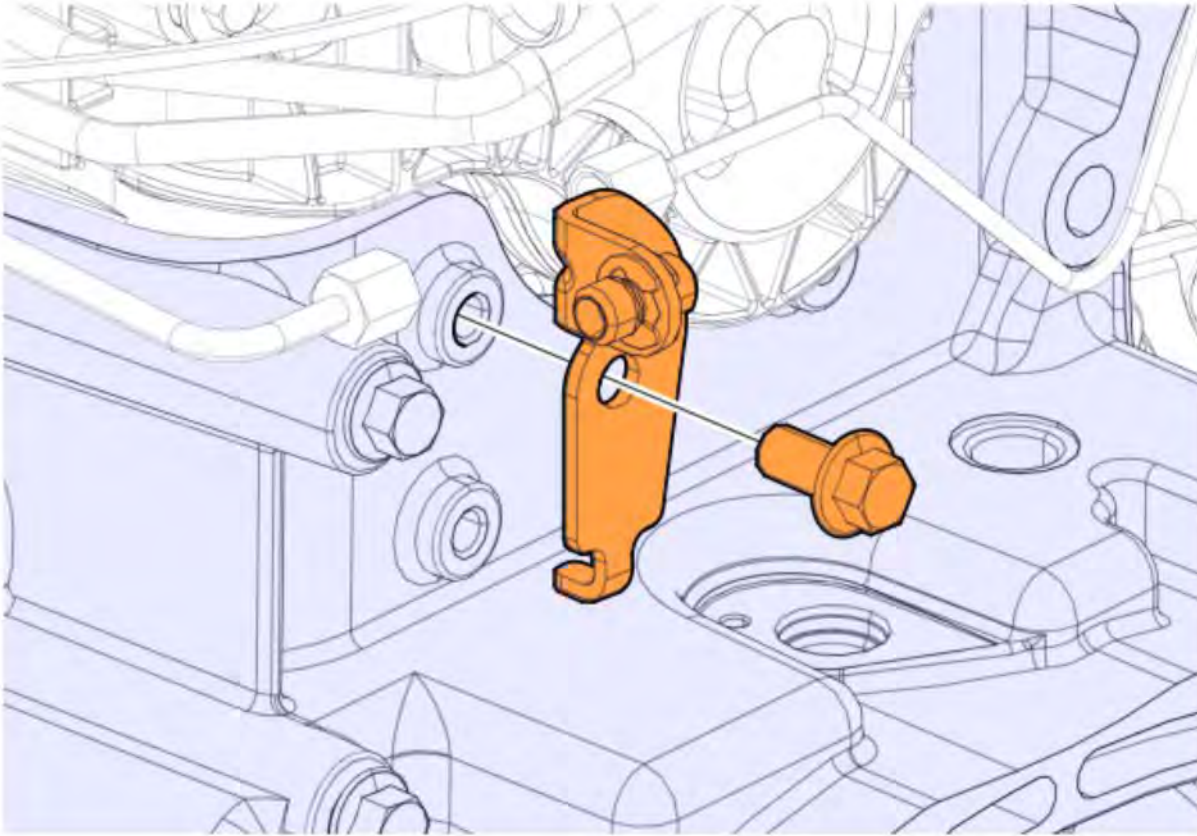

104	Disconnect the connector.
-----	---------------------------

105	Remove the cable tie.
-----	-----------------------

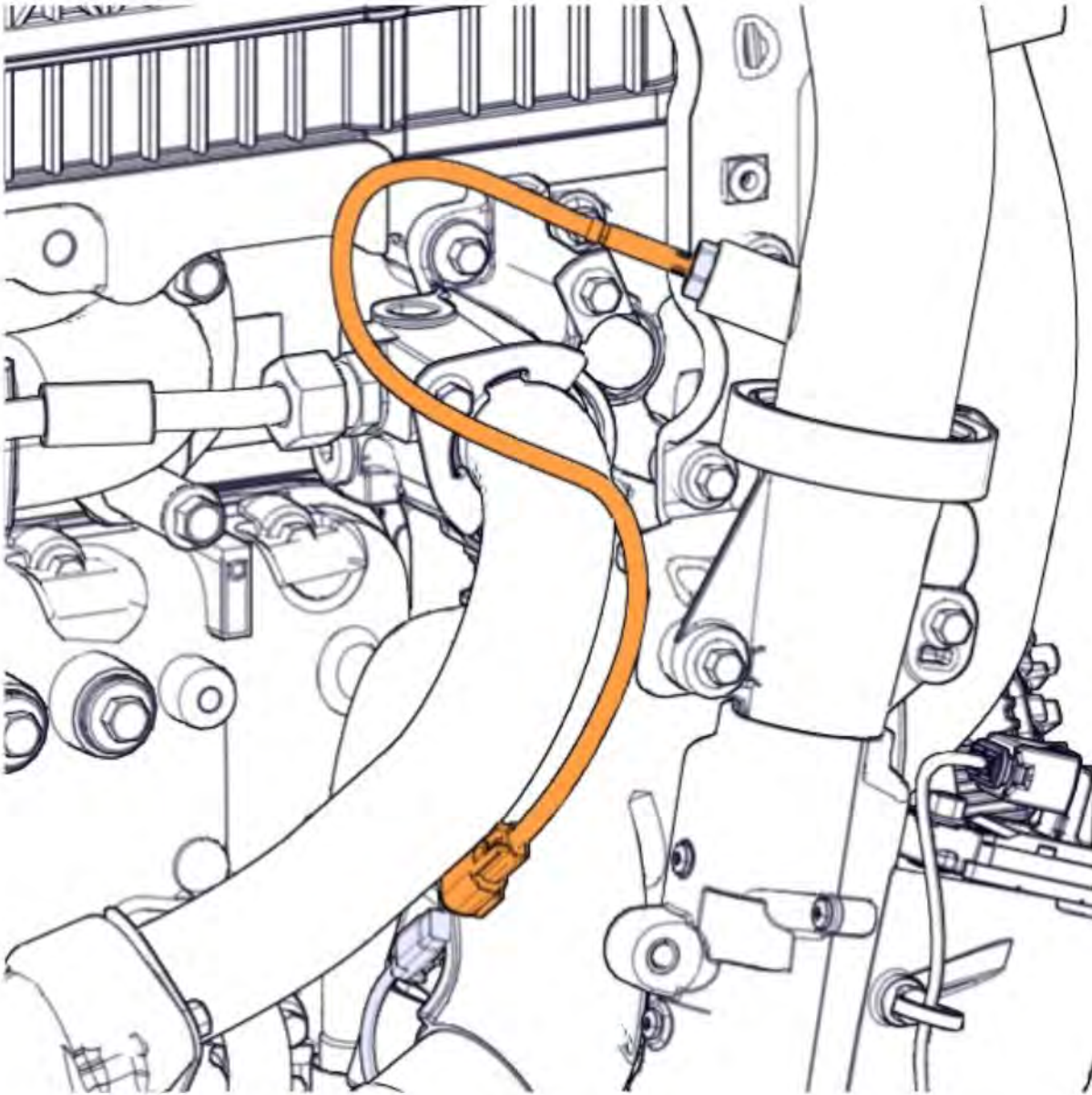

106	Remove the screws.
-----	--------------------

107	Remove the clamp.
-----	-------------------

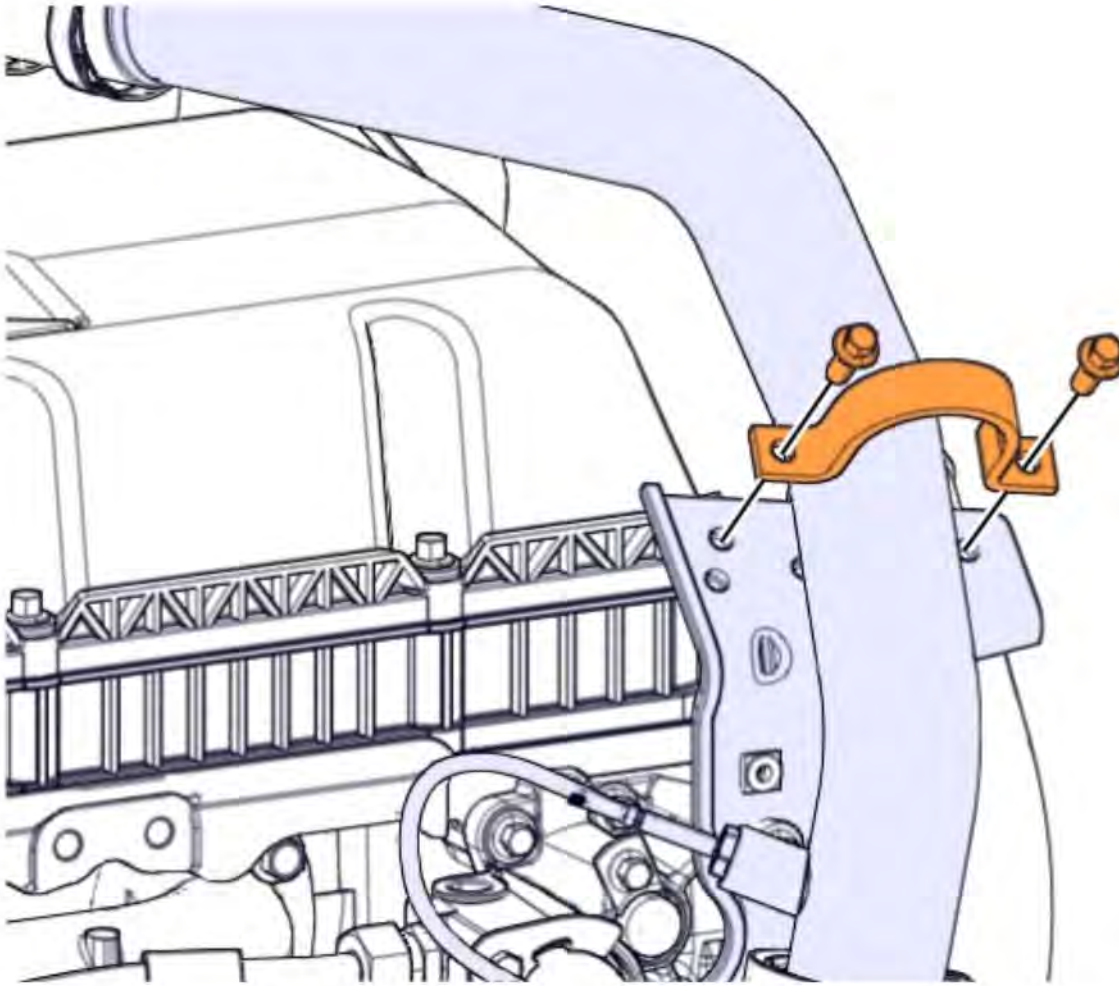

108 Loosen the clamps.



Note

Note the positions.

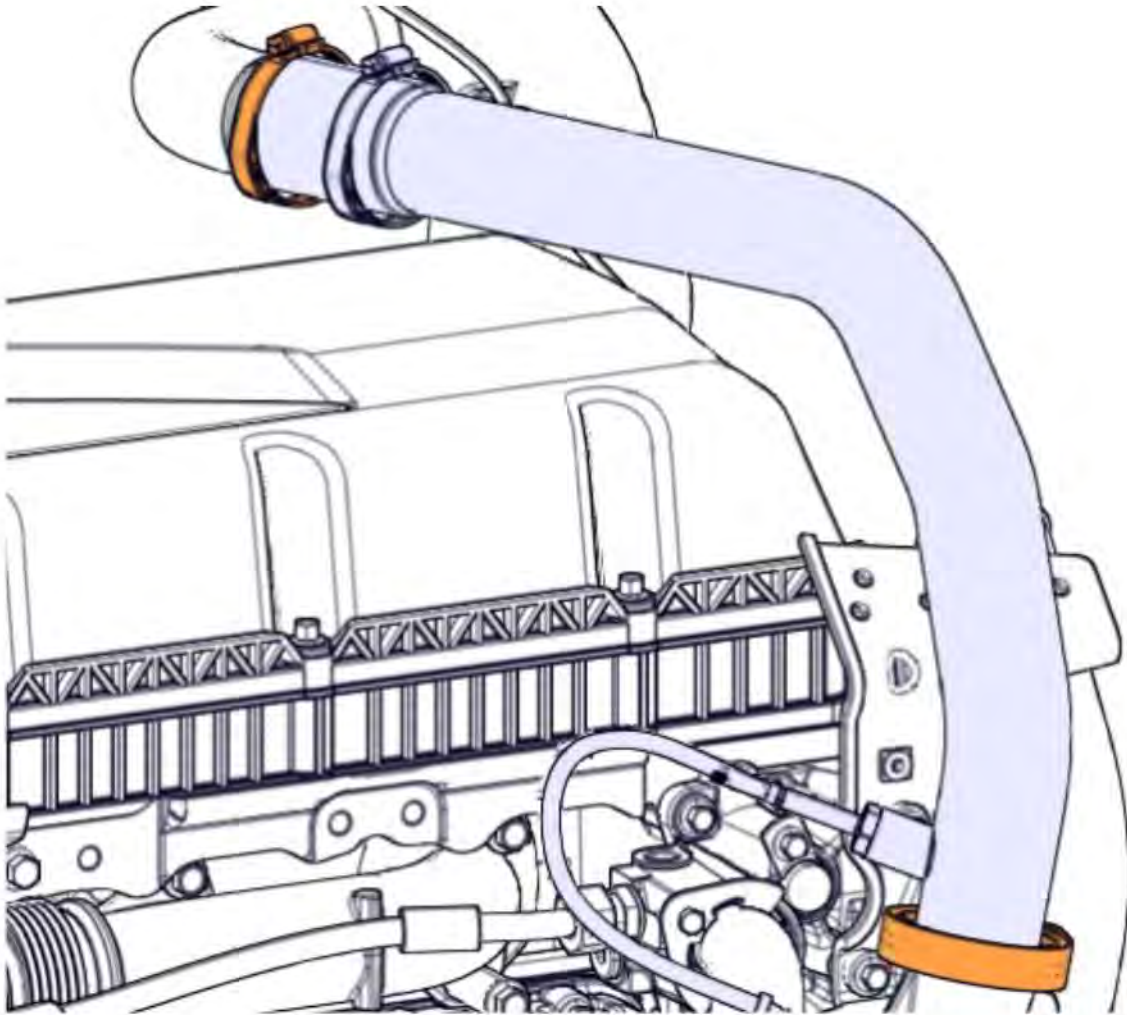

109	Remove the pipe.
-----	------------------

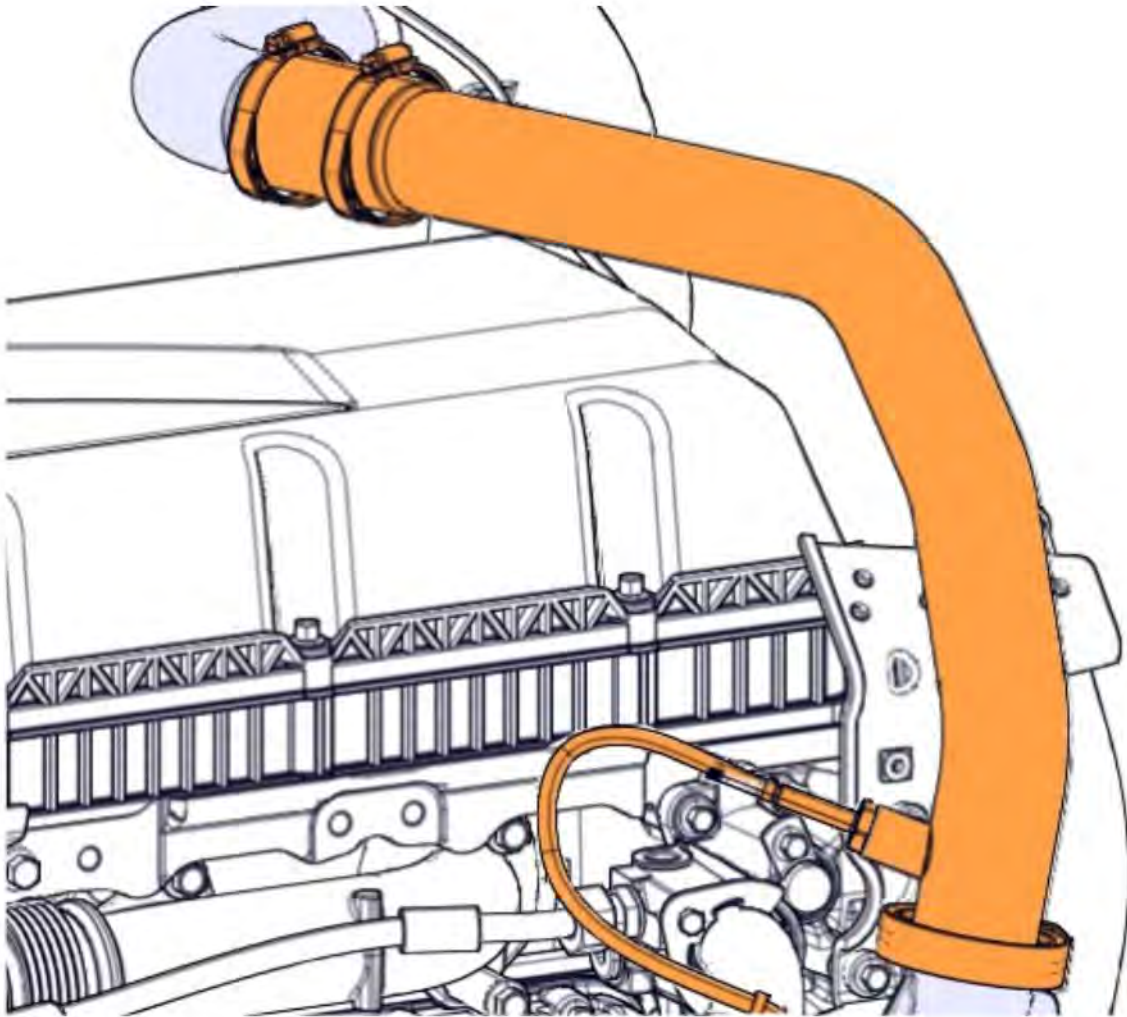

110	Remove the screw.
-----	-------------------

111	Remove the pipe.
-----	------------------

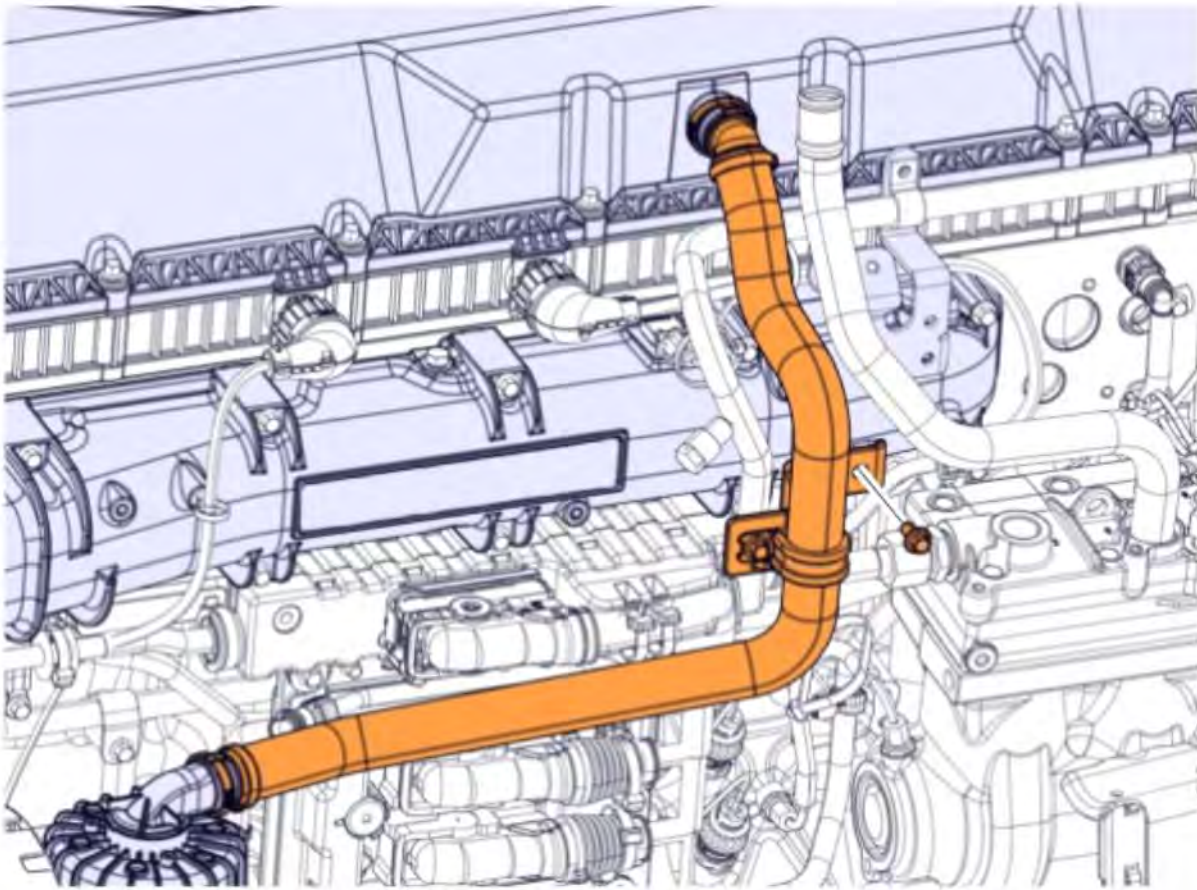

112 Remove the pipe.



Note

If not previously removed.

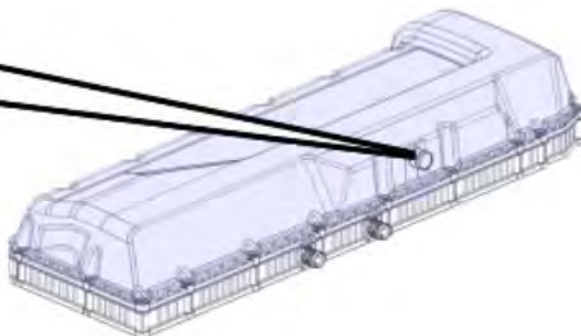
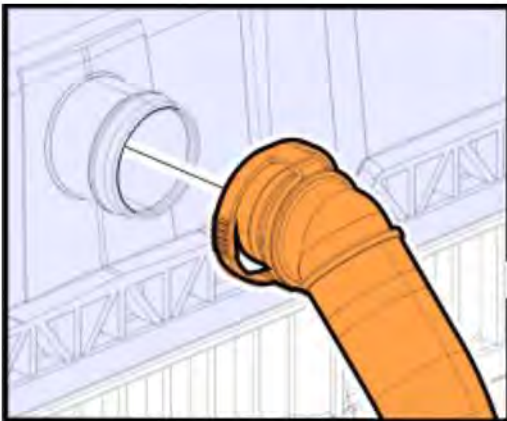

113 Loosen the screws.

114 Remove the valve cover.



Service hint

It is possible, when removing a valve cover screw, that the crush sleeve is drawn out with it. Take care to prevent the sleeve from falling into the gear train as this could result in engine damage.

**Service hint**

You do not need to loosen the valve or adjust the injector or the rocker arm shaft to replace the timing gear plate. A revised procedure for adjusting gear lash has been created.

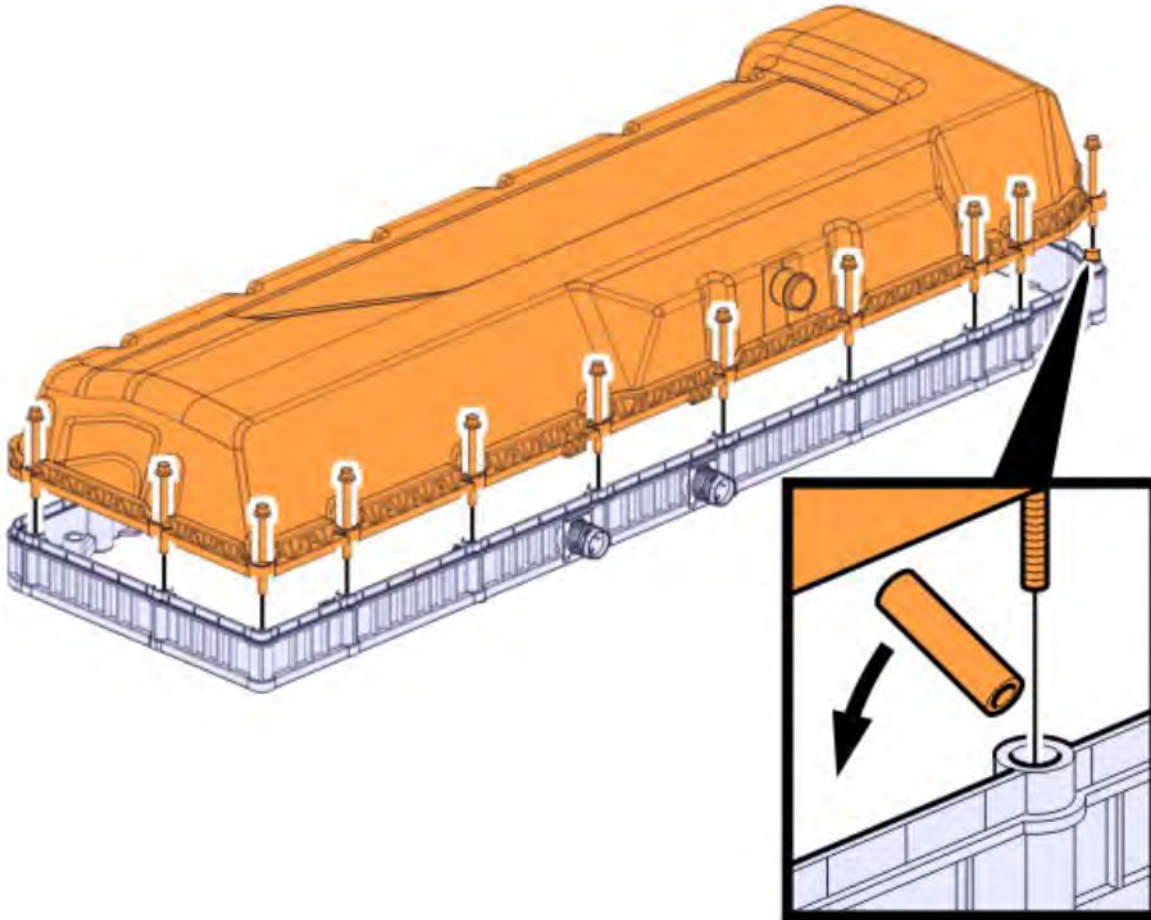

115 Disconnect the connectors.

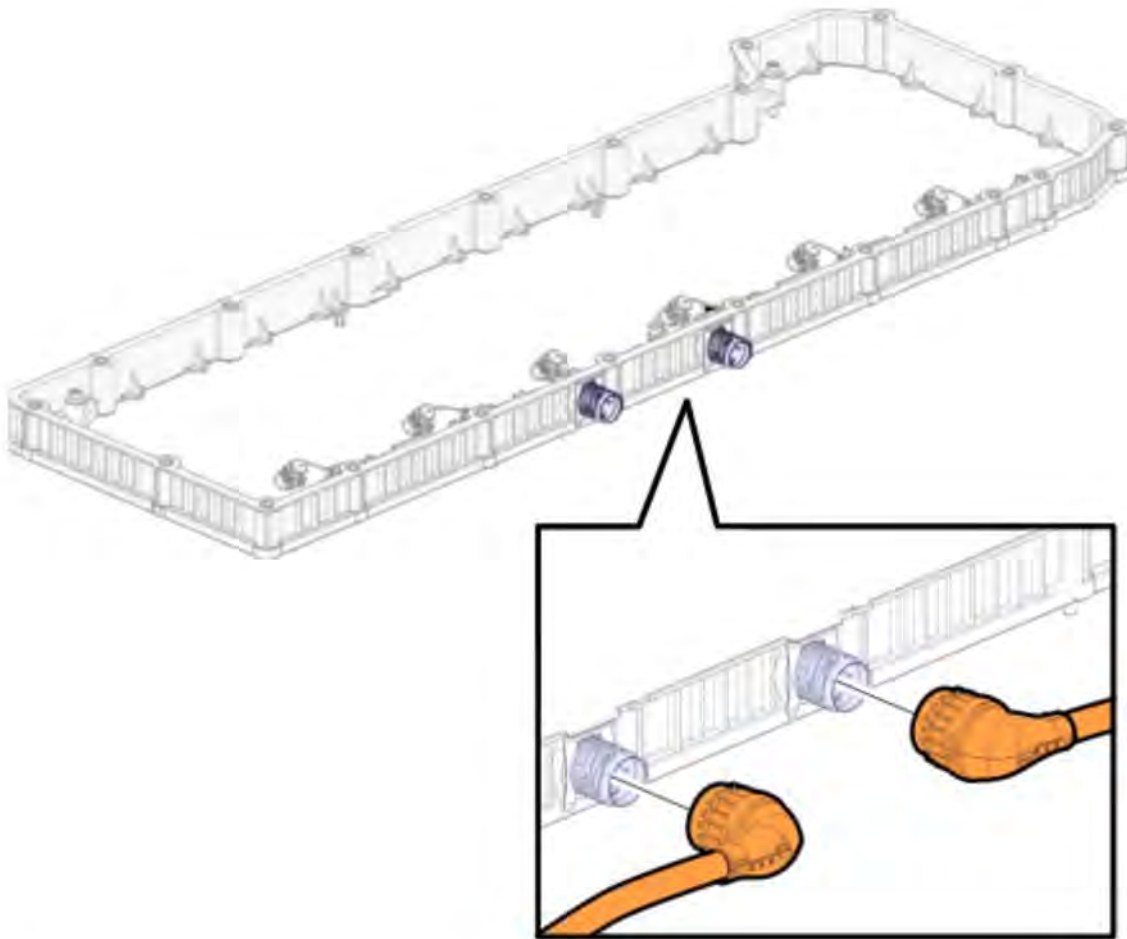

116	Disconnect the connectors.
------------	----------------------------

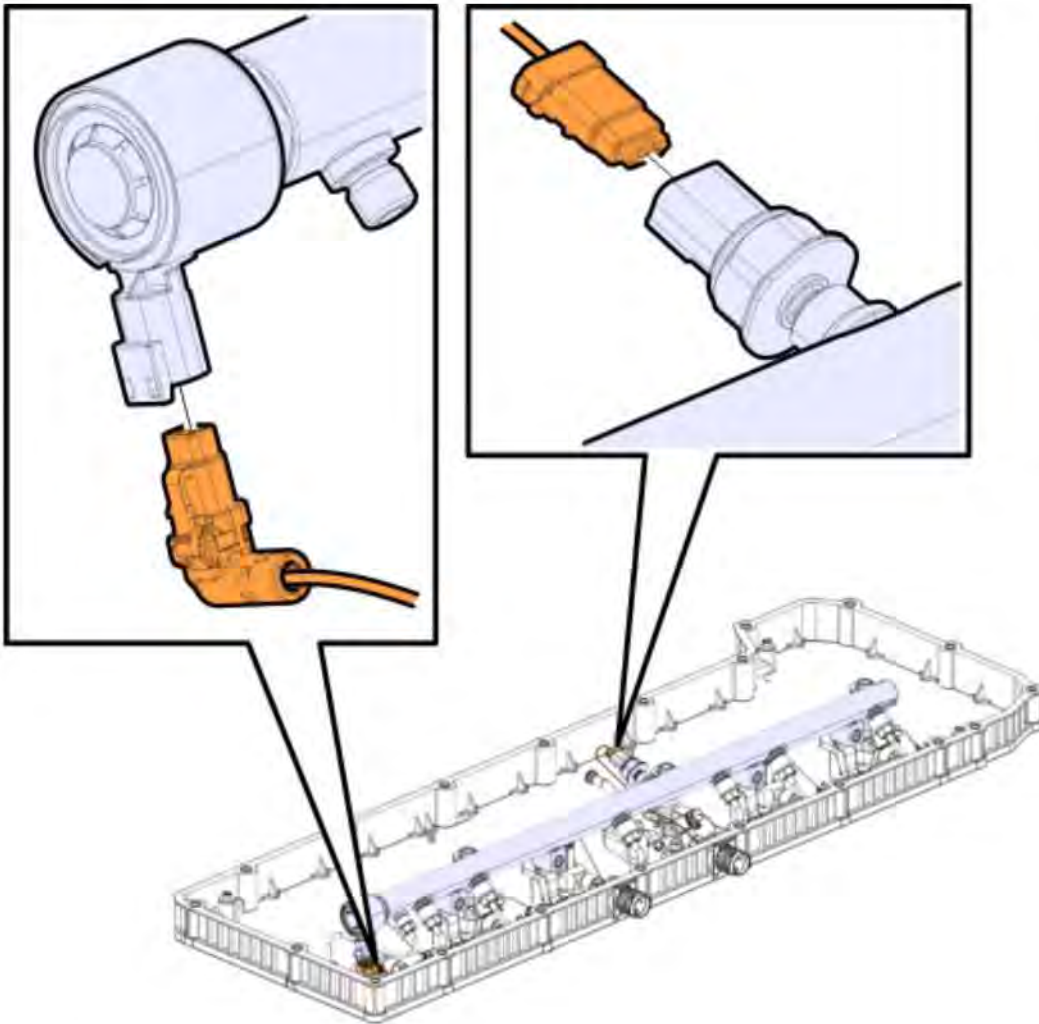

117	Loosen the screws.
-----	--------------------

118	Disconnect the connectors.
-----	----------------------------

119	Remove the frame.
-----	-------------------

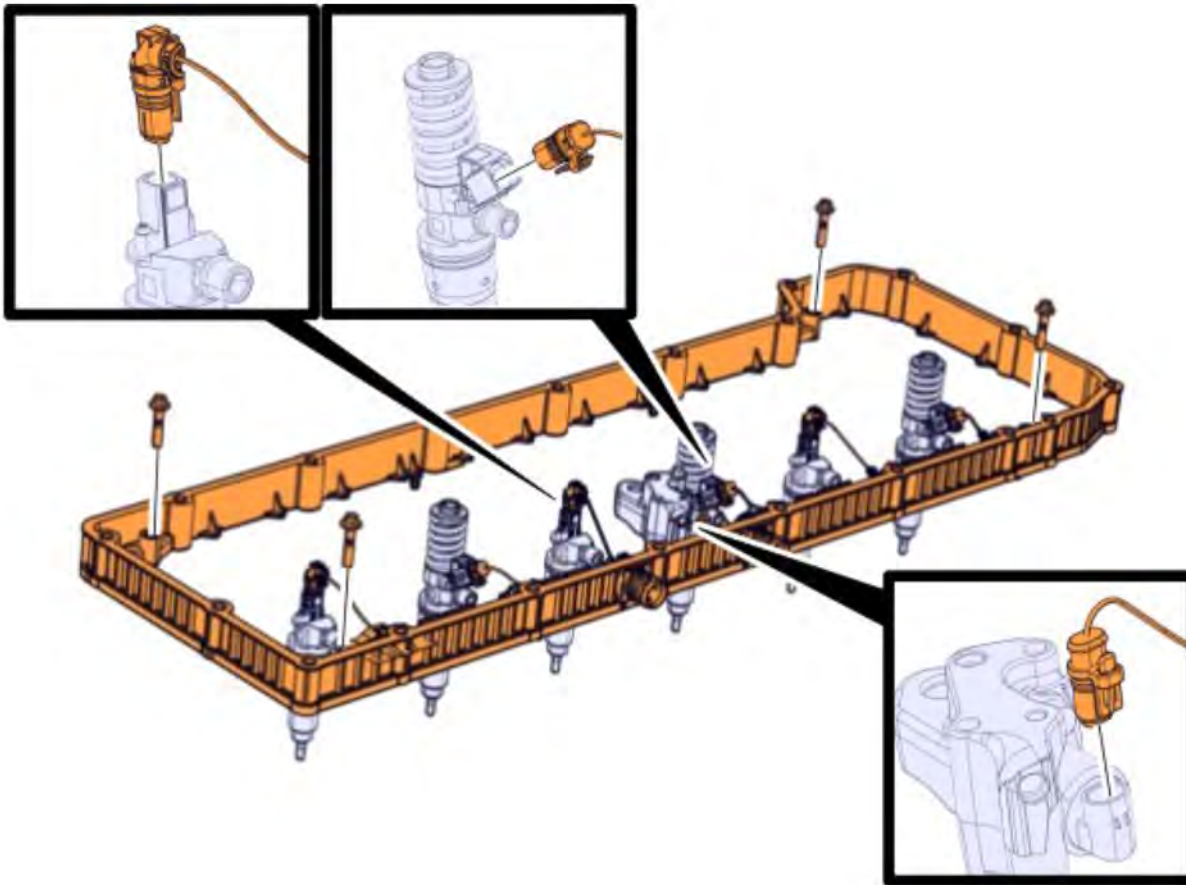

120 Remove the gasket.

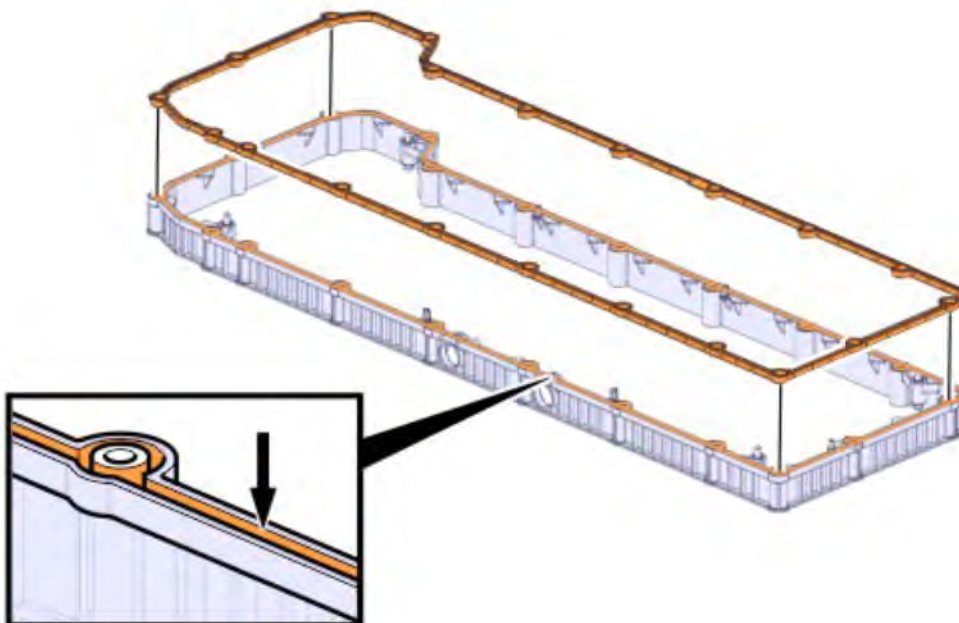

121 Remove the screws.



Service hint

The screws cannot be removed from the timing gear cover.

Copyright to this documentation belongs to the Volvo Group. No reproduction, copying, change, amendment or other similar disposal is entitled without prior written consent by the Volvo Group

The information contained herein is current at the time of its original distribution, but is subject to change. The reader is advised that printed copies are uncontrolled.

122 Remove the timing gear cover.

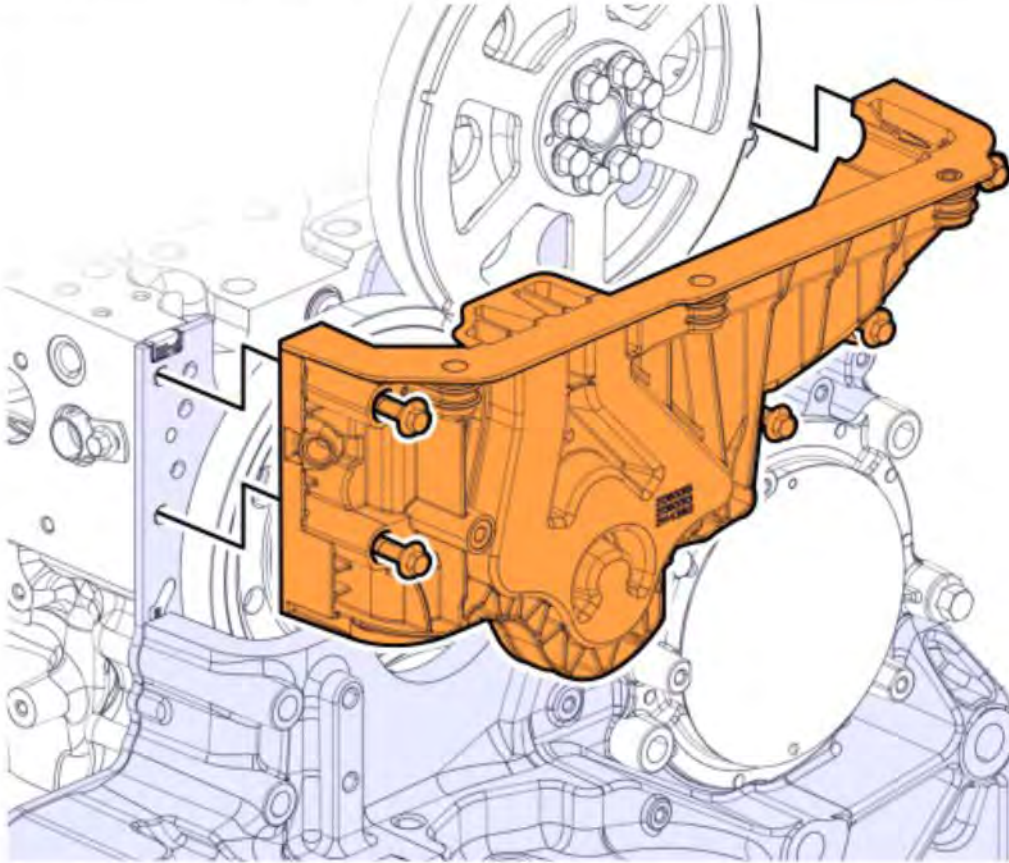

123 Remove the gasket.



Note

Discard the gasket.

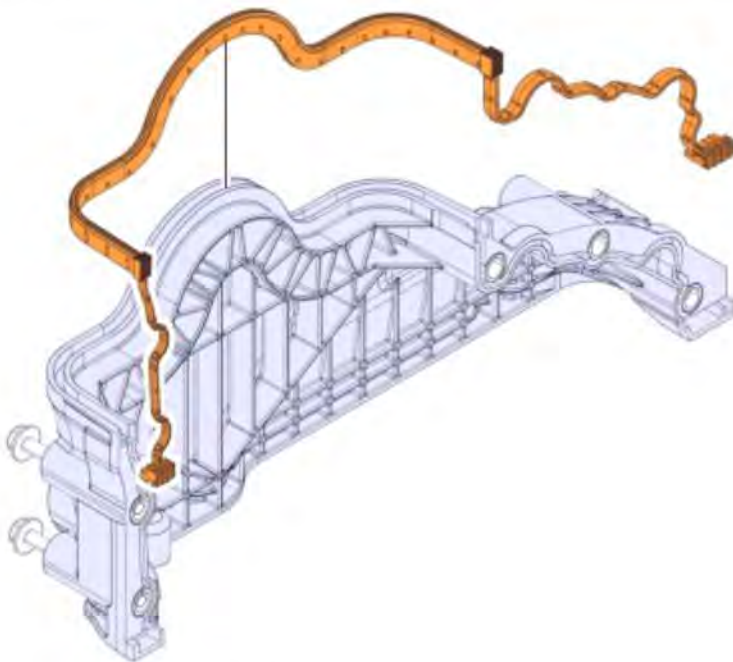

124 Remove the plug.

Copyright to this documentation belongs to the Volvo Group. No reproduction, copying, change, amendment or other similar disposal is entitled without prior written consent by the Volvo Group

The information contained herein is current at the time of its original distribution, but is subject to change. The reader is advised that printed copies are uncontrolled.

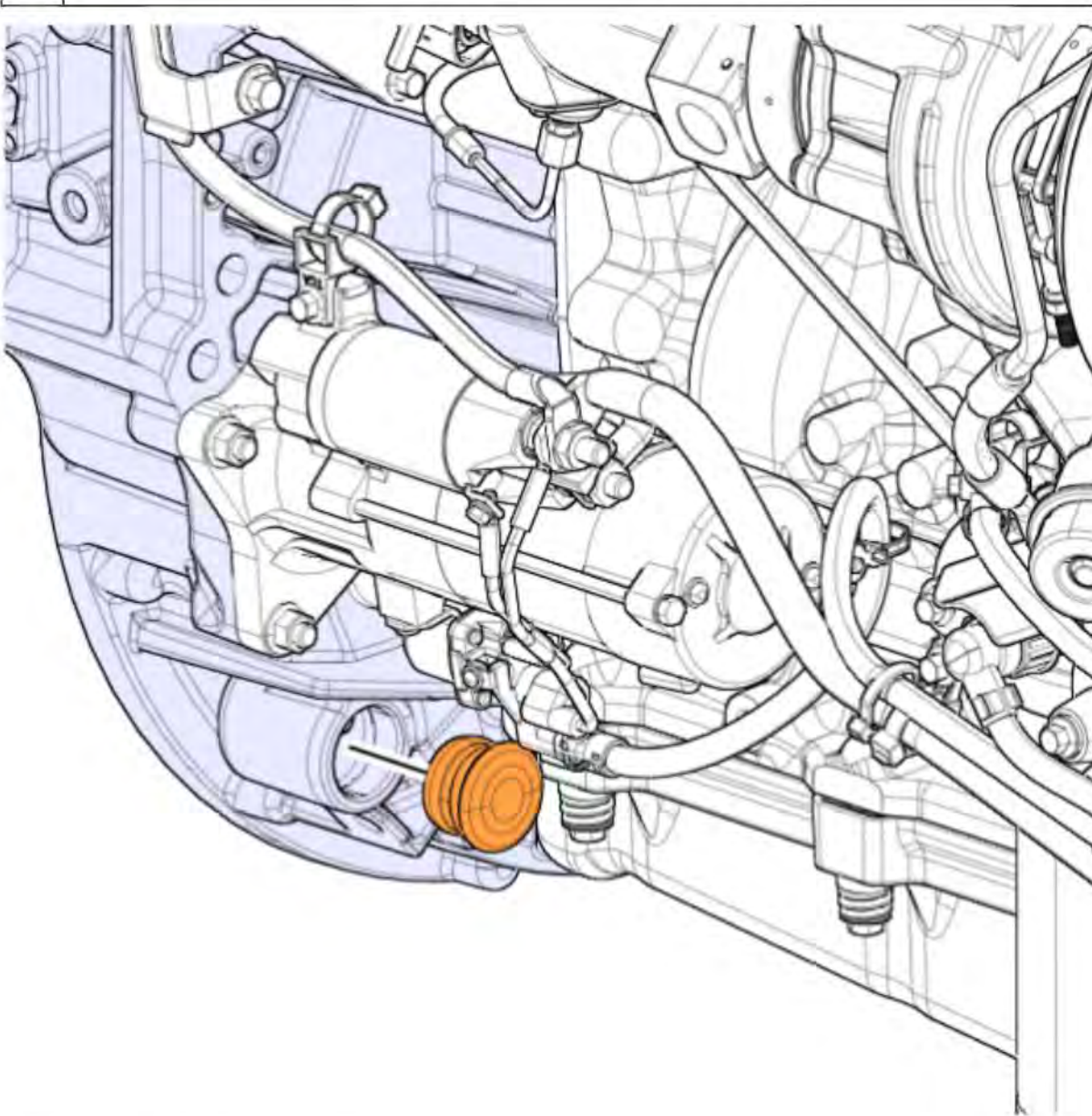

125	Install the cranking tool (A).	
	Required material	
	CRANKING TOOL	88840317

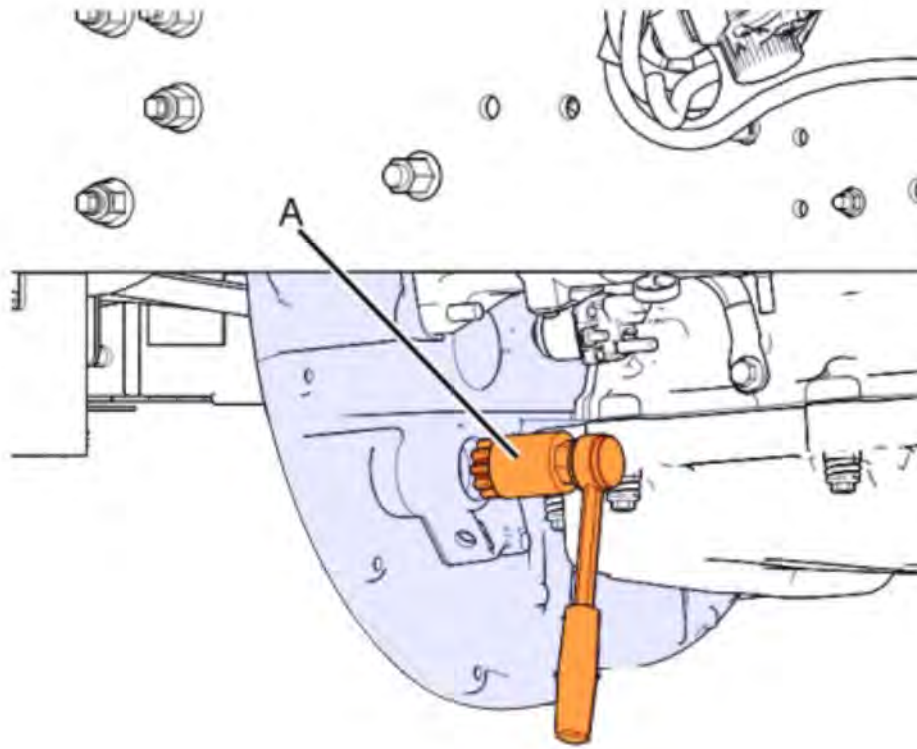

126 Remove the plug.

127 Check the marking (0).

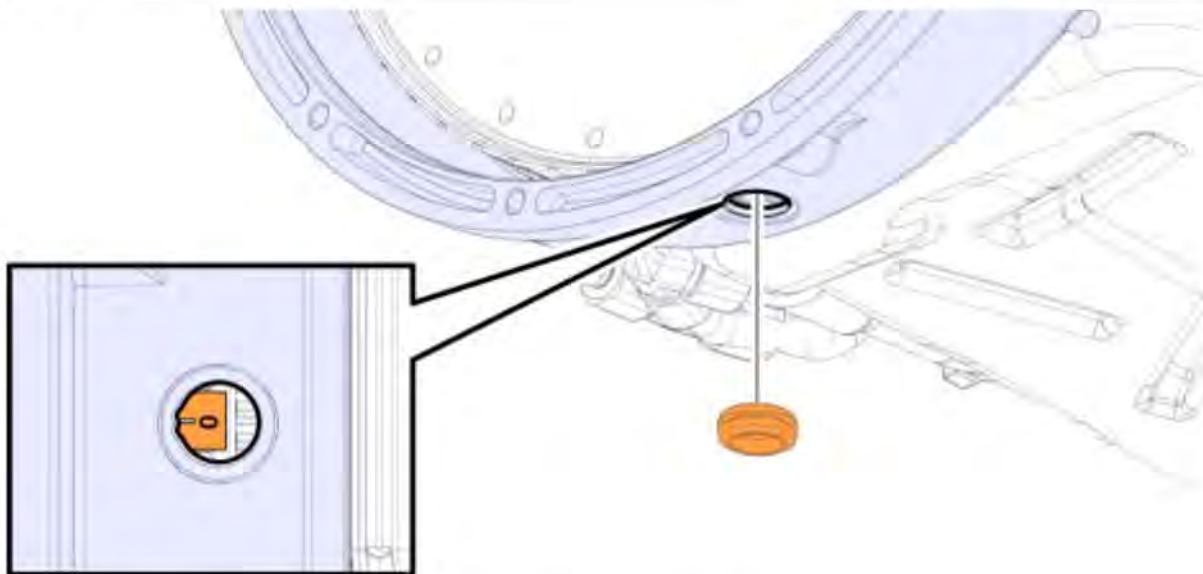

128 Perform this procedure when the condition below is met.

Conditions

- If the flywheel is not in the TDC (Top Dead Center) position.

- ▶ Rotate the flywheel to the TDC marking (0).

Note
Do not use power tools.

Copyright to this documentation belongs to the Volvo Group. No reproduction, copying, change, amendment or other similar disposal is entitled without prior written consent by the Volvo Group

The information contained herein is current at the time of its original distribution, but is subject to change. The reader is advised that printed copies are uncontrolled.



Note

Rotate the flywheel in the normal engine rotation direction.

129 This step contains 2 alternatives.

Select one of the valid alternatives below.

Alternative 1 / 2

- ▶ Install the tool.

Required material

fixture

[88800570](#)

- ▶ Install the screw.

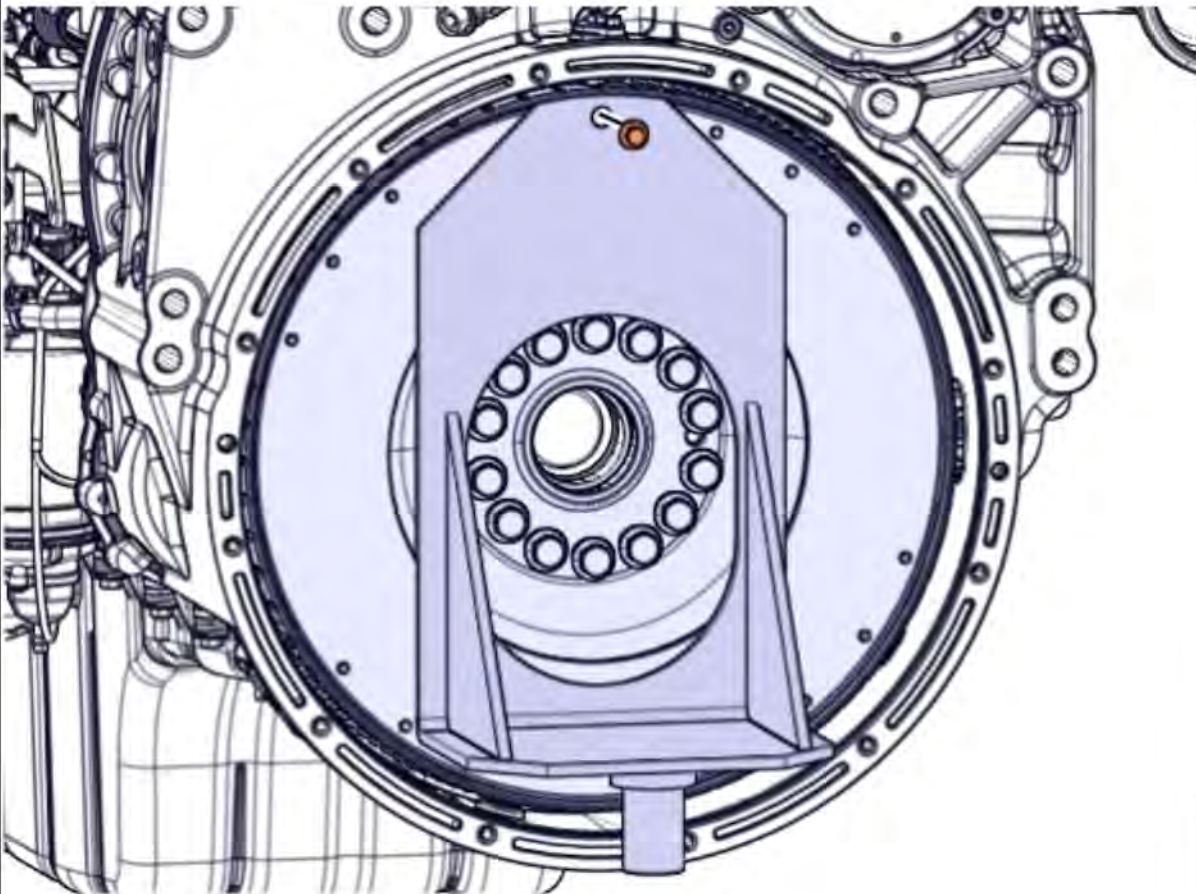

- ▶ Install the screws.

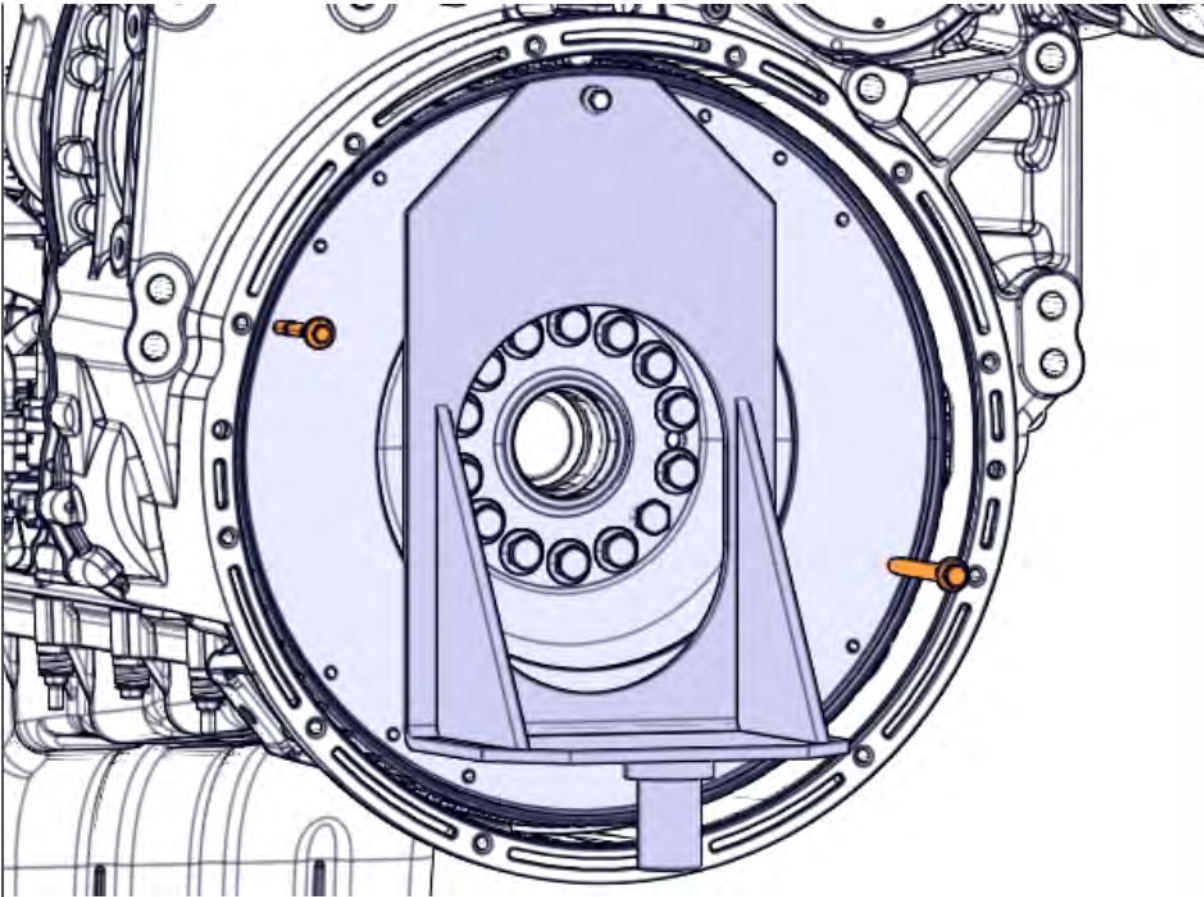

▶ Remove the screws.

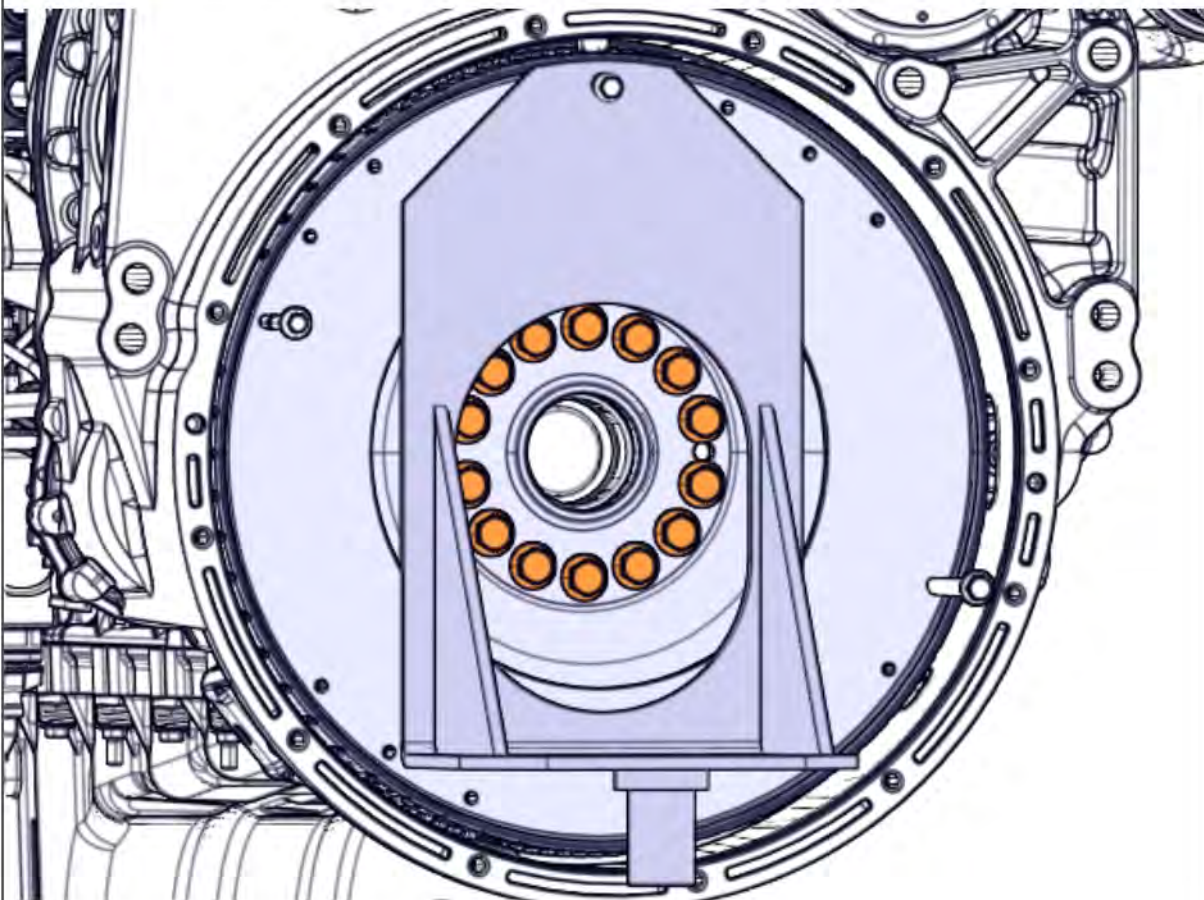

▶ Remove the flywheel.

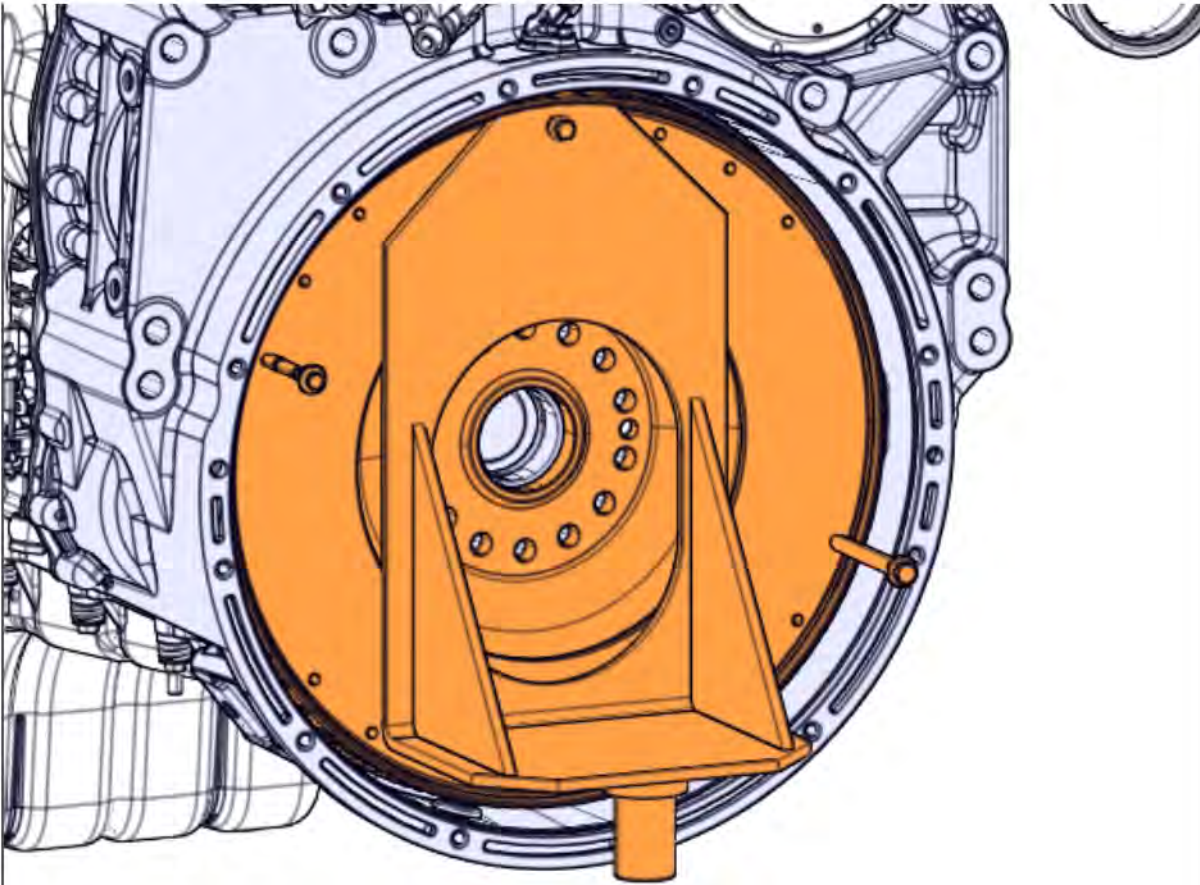

Alternative 2 / 2

- ▶ Remove the screws.
- ▶ Remove the thrust plate.
- ▶ Remove the flexplate.
- ▶ Remove the flywheel.

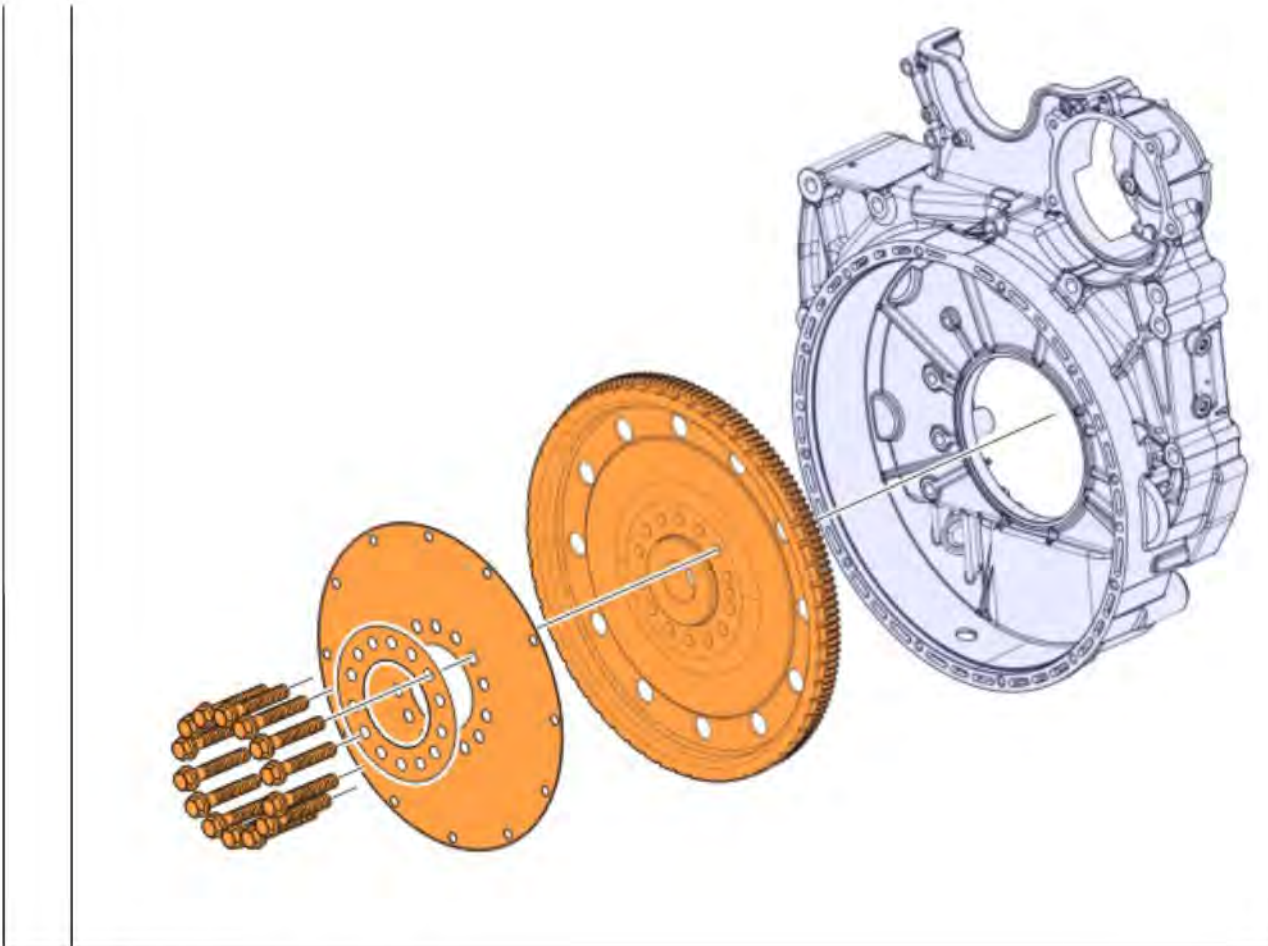

130 Position a draining container.



WARNING

Risk of serious burns.

Contact with a hot engine or hot engine oil can cause serious burns.

- ▶ Take precautions when draining the oil. Wear gloves and let the engine cool down before draining.

131 Remove the drain plug.

132 Drain the oil.

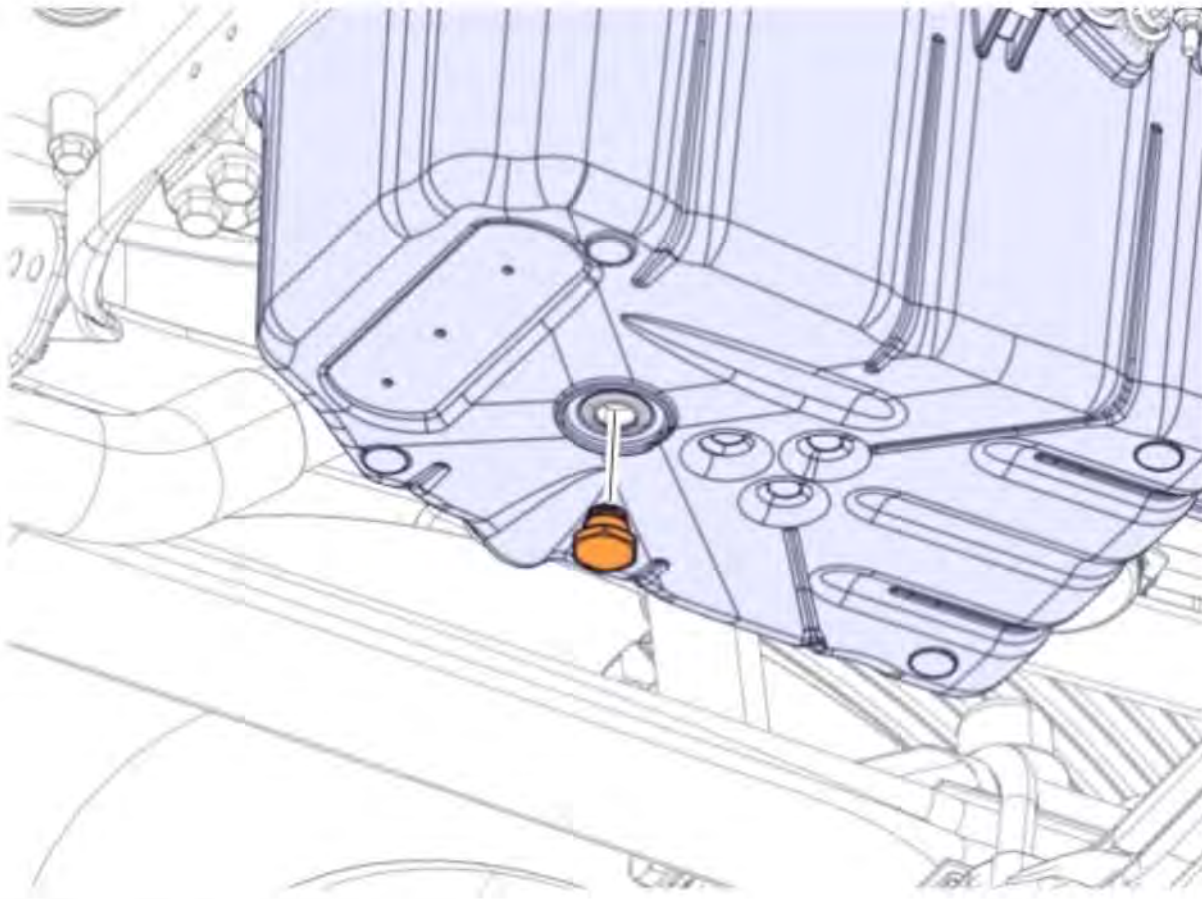



133	Install the drain plug.		
		i	Note Always use a new gasket.

134	Torque tighten the plug.		
		Tightening torque	
	Oil pan, drain plug		60 ±10 Nm (44 ±7 lb _f ·ft)

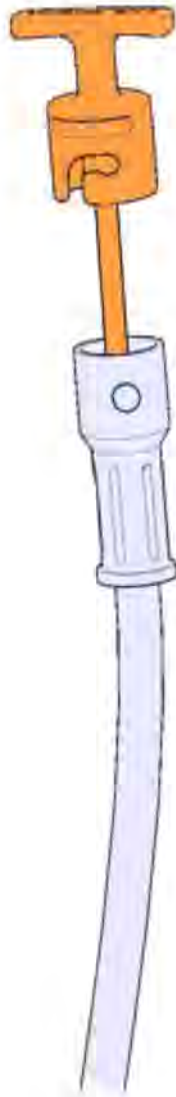
135	Remove the dipstick.		
		Tech data	
	The distance the dipstick is drawn out from the outer casing		≈ 0.5 m (1 ft – 7.7 in)



136	Disconnect the connector (3).
137	Depress the release ring (2) remove the dipstick pipe.
	<p>Note Pull to remove.</p>
	<p>Note Use a suitable tool to depress.</p>
138	Remove the screws.
139	Remove the pipe (1).

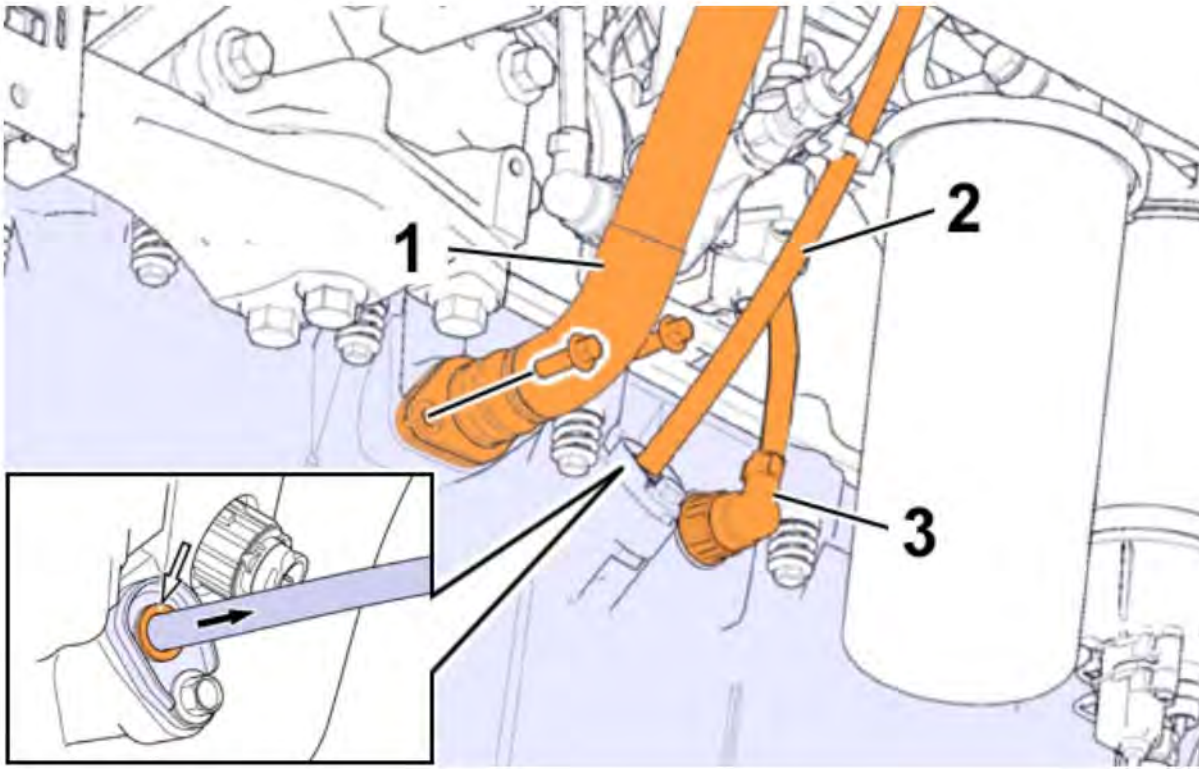

140	Remove the screws.
-----	--------------------

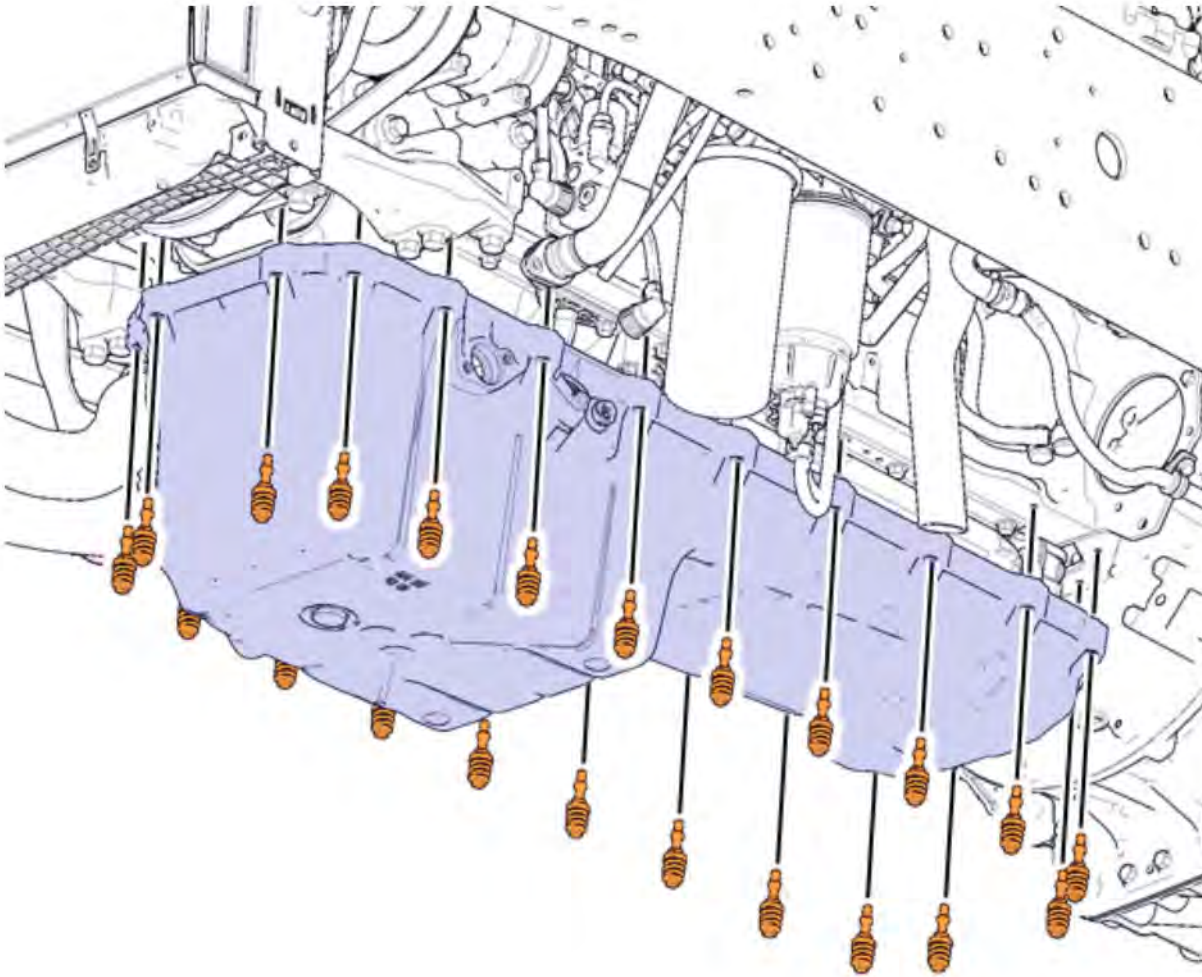
**141** Remove the oil pan.**Note**

Get help if needed.

**Note**

Lower the component carefully.

**Note**

Ensure that there is no damage to the oil pickup tube and oil pump gear.

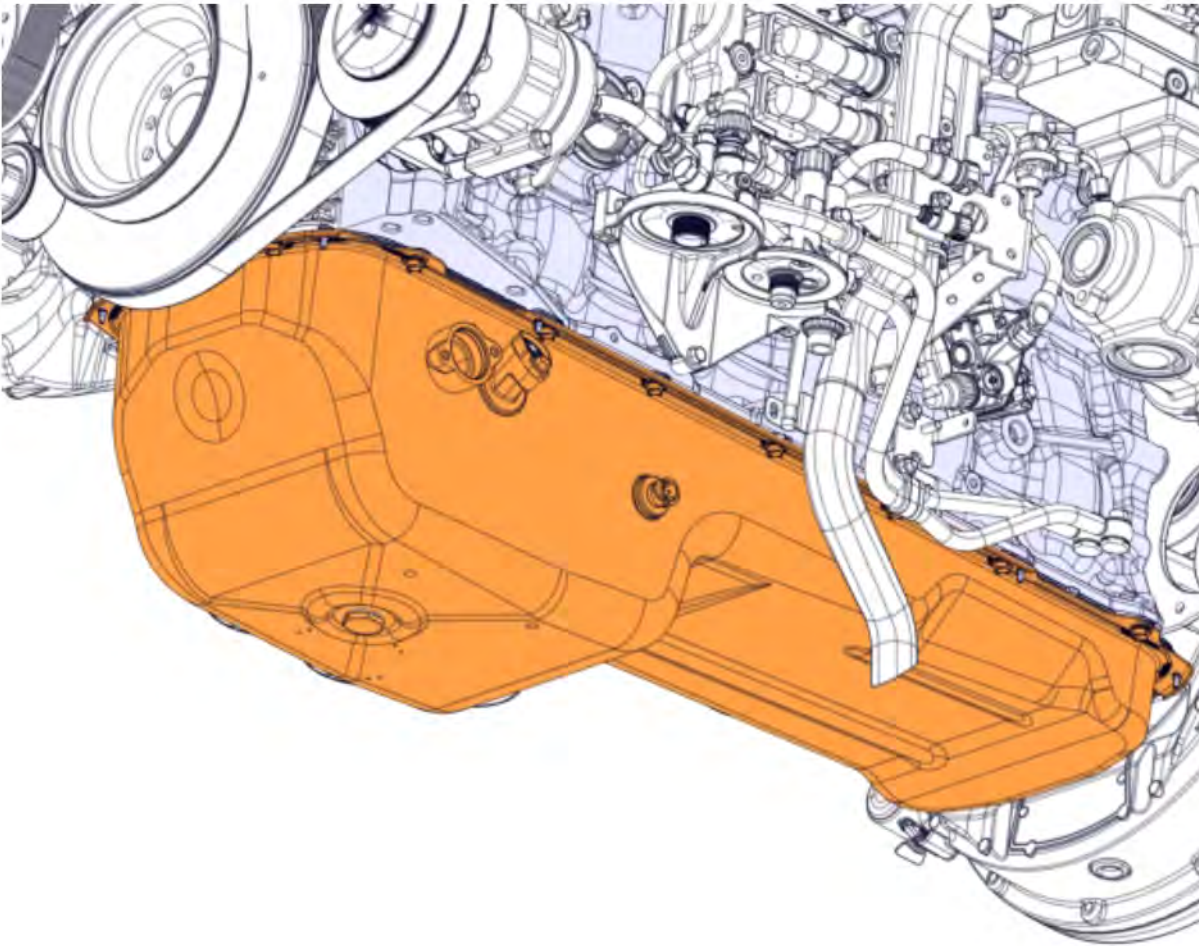

142	Remove the gasket.
-----	--------------------

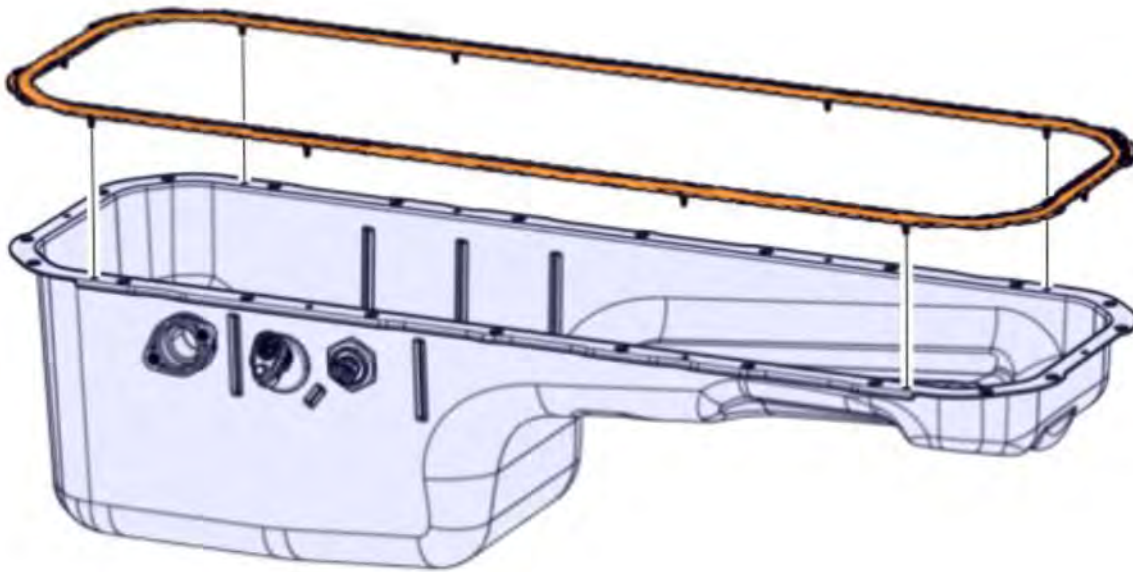

143	Clean the oil filter housing.
-----	-------------------------------

144	Remove the oil filters.
-----	-------------------------

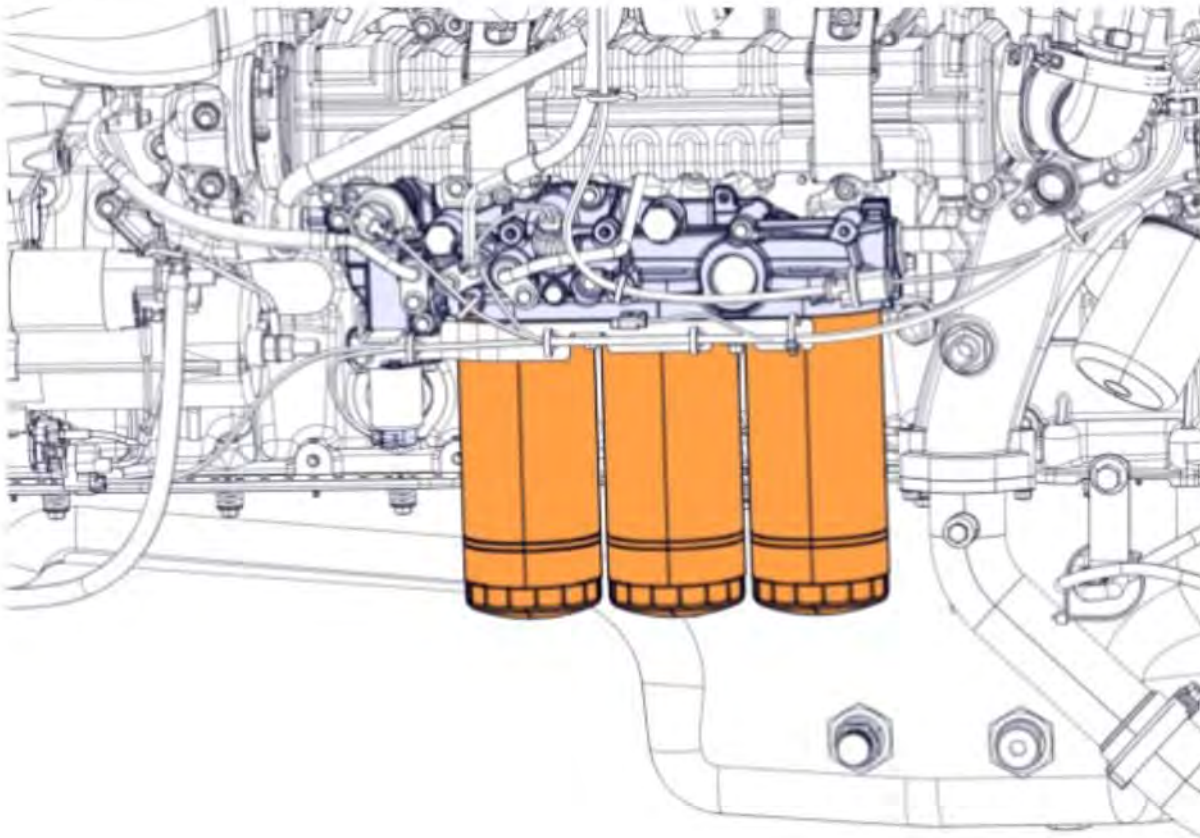

145 This step contains 2 alternatives.
 Select one of the valid alternatives below.

Alternative 1 / 2

Conditions

- Old variant of seal
- ▶ Install tool (B) on tool (A).

Required material

IMPACT WRENCH	9996400
puller	9990192

i Note
 Ensure that the tools are clean and intact.

- ▶ Insert the puller (B) between the seal and the crankshaft using an impact wrench (A).

i Note
 Take care not to damage the crankshaft surface.

- ▶ Remove the seal.

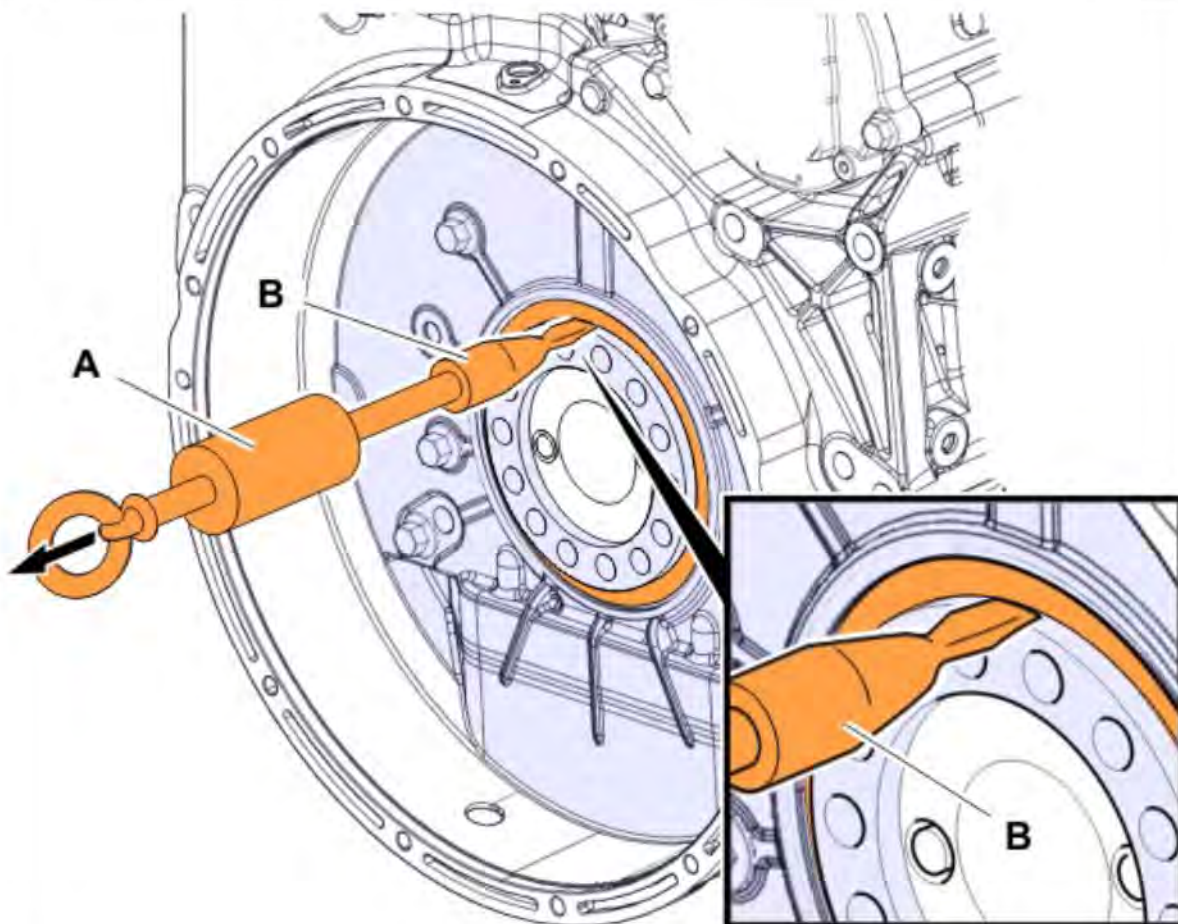

Alternative 2 / 2

Copyright to this documentation belongs to the Volvo Group. No reproduction, copying, change, amendment or other similar disposal is entitled without prior written consent by the Volvo Group

The information contained herein is current at the time of its original distribution, but is subject to change. The reader is advised that printed copies are uncontrolled.

Conditions

- New variant of seal

- ▶ Clean the area around the seal.

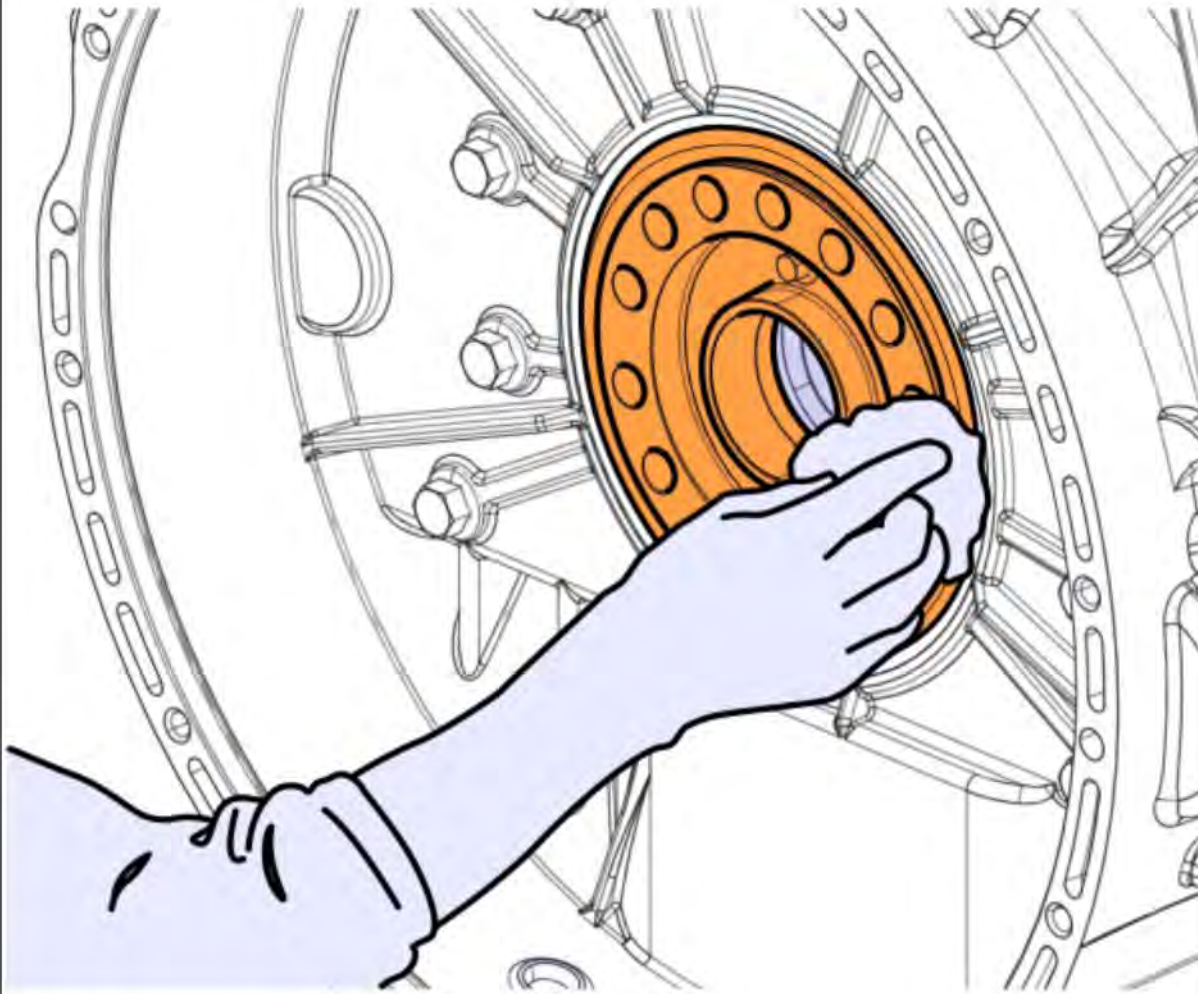

- ▶ Release the seal.

**Service hint**

Tap the seal to loosen it from the contact surfaces.

**Service hint**

Use a plastic chisel and a hammer.

**Service hint**

Lubricate the contact surfaces to facilitate removal of the seal.

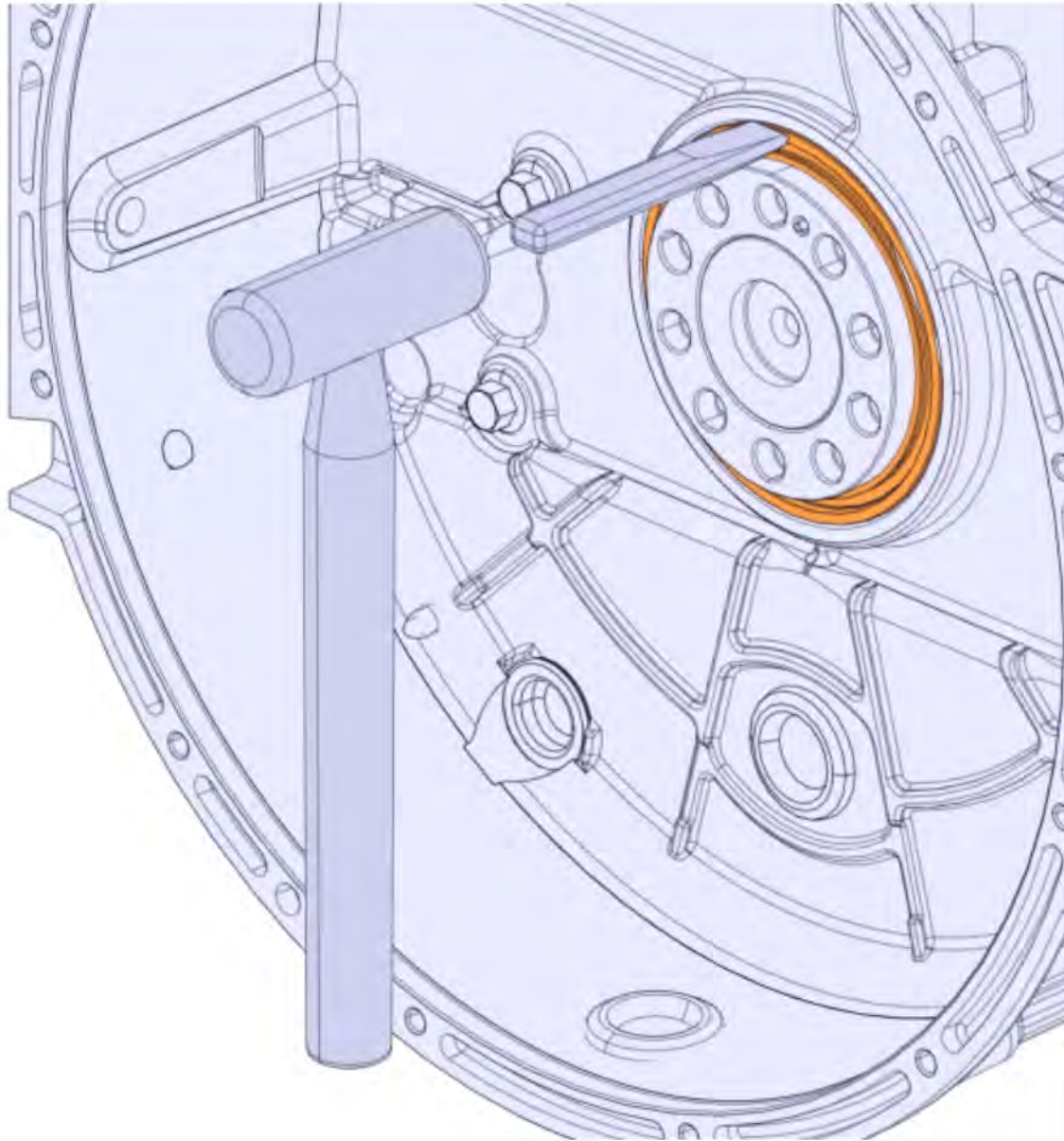

► Install the tool.

Required material

DISASSEMBLY TOOL

[88800502](#)



Note

The arms of the tool can be adjusted to different diameters.

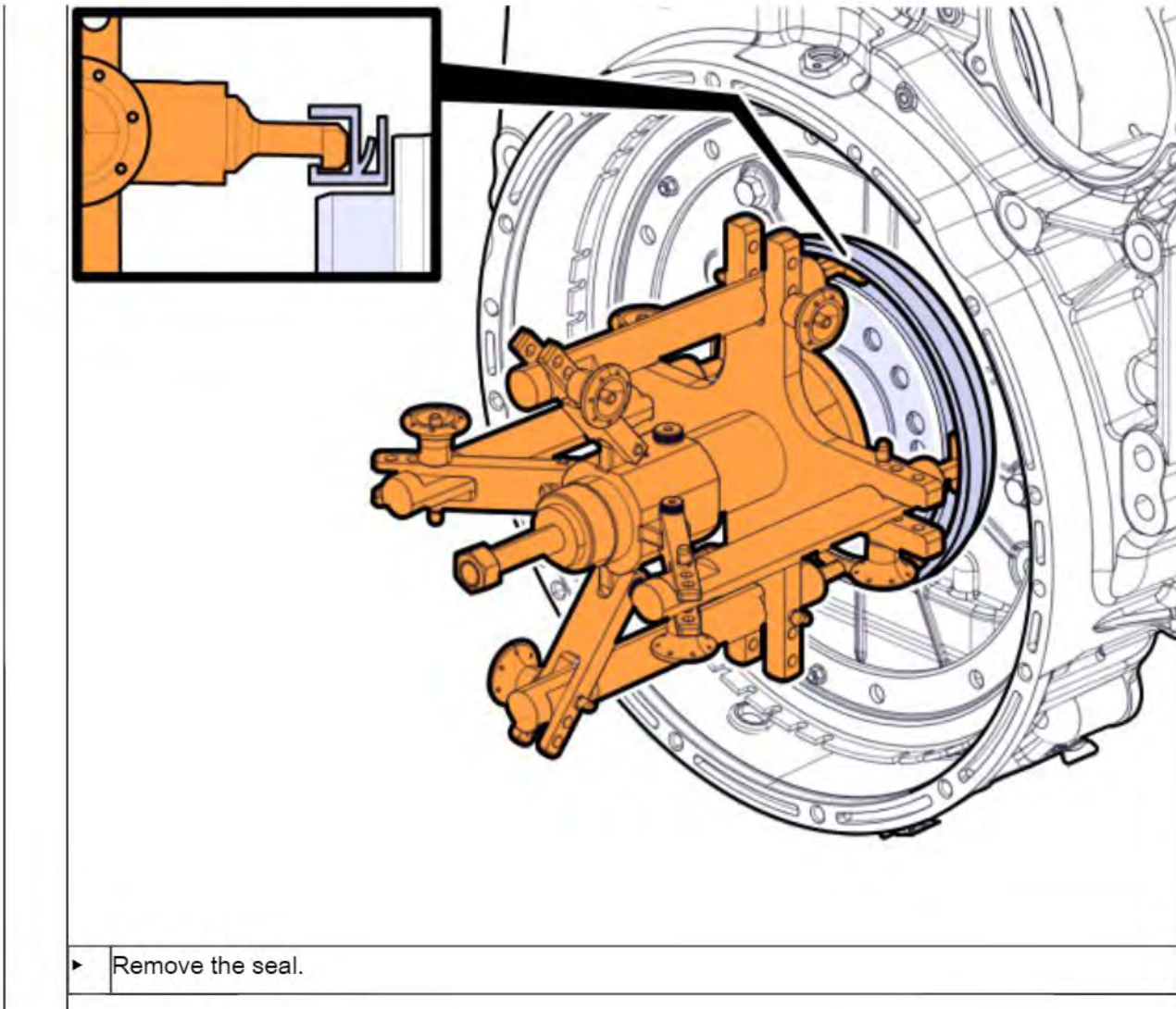

146 Remove the screws and bracket.

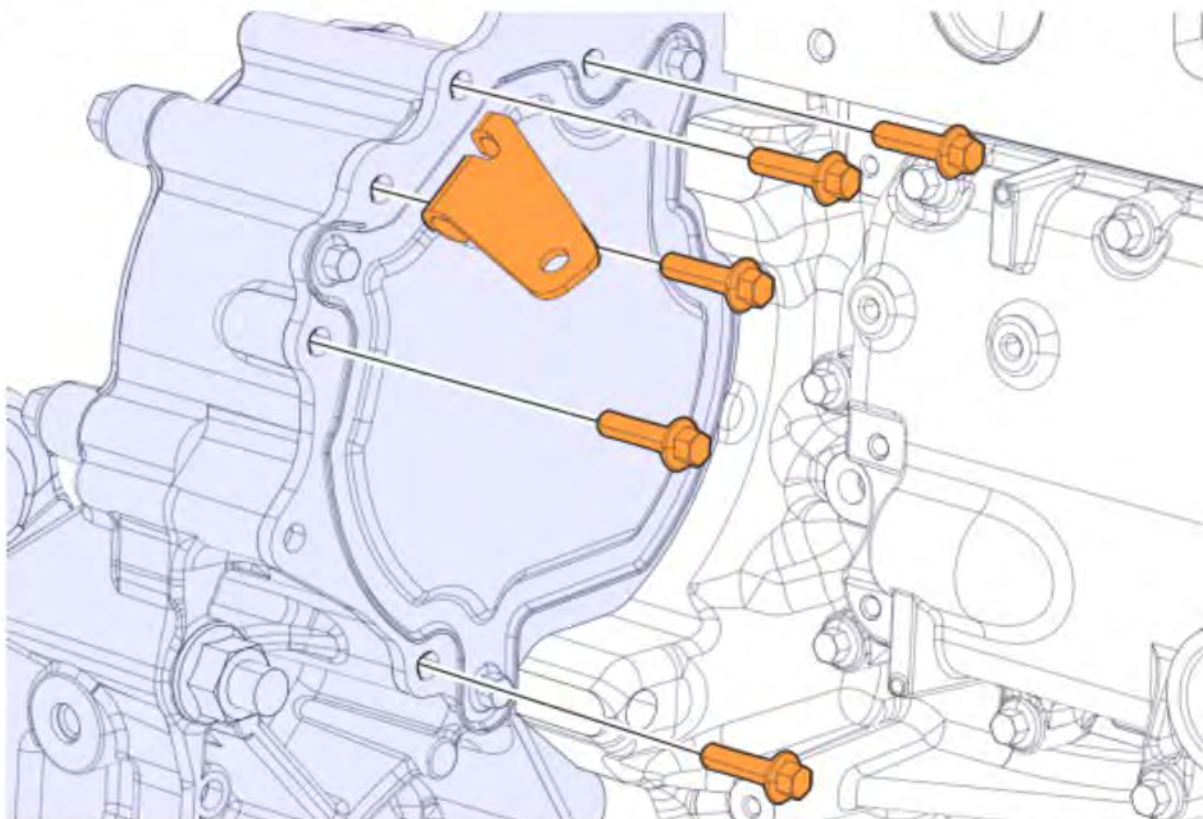

Copyright to this documentation belongs to the Volvo Group. No reproduction, copying, change, amendment or other similar disposal is entitled without prior written consent by the Volvo Group

The information contained herein is current at the time of its original distribution, but is subject to change. The reader is advised that printed copies are uncontrolled.

147 Remove the screws.



Note

Some housings may not include all the screws shown.

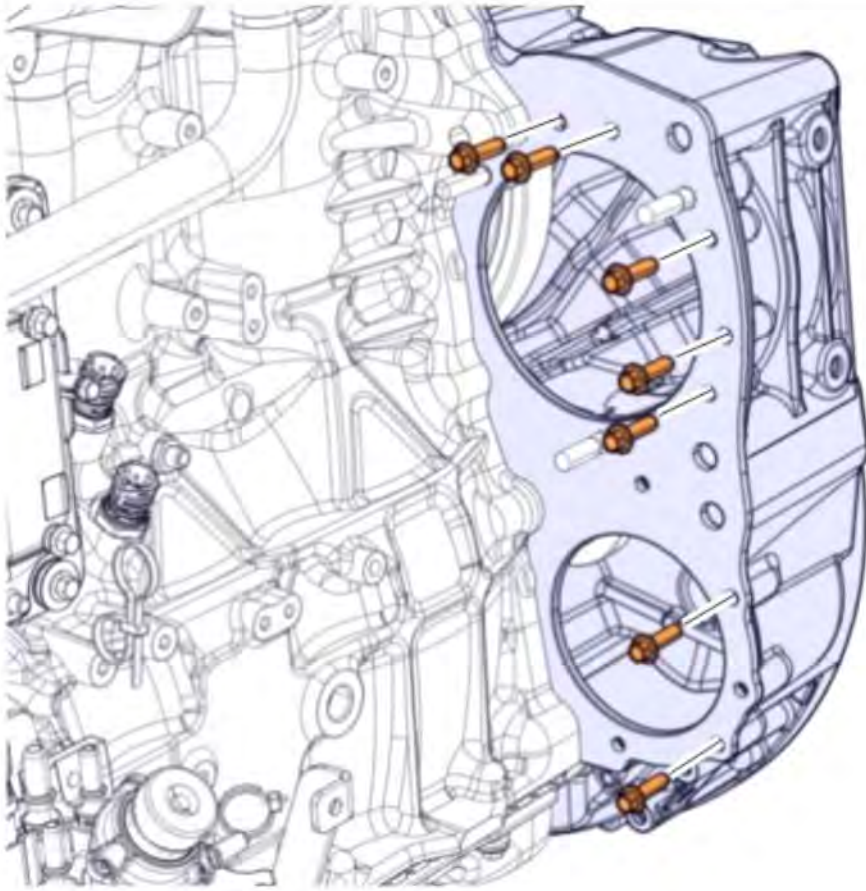

148 Remove the screws.

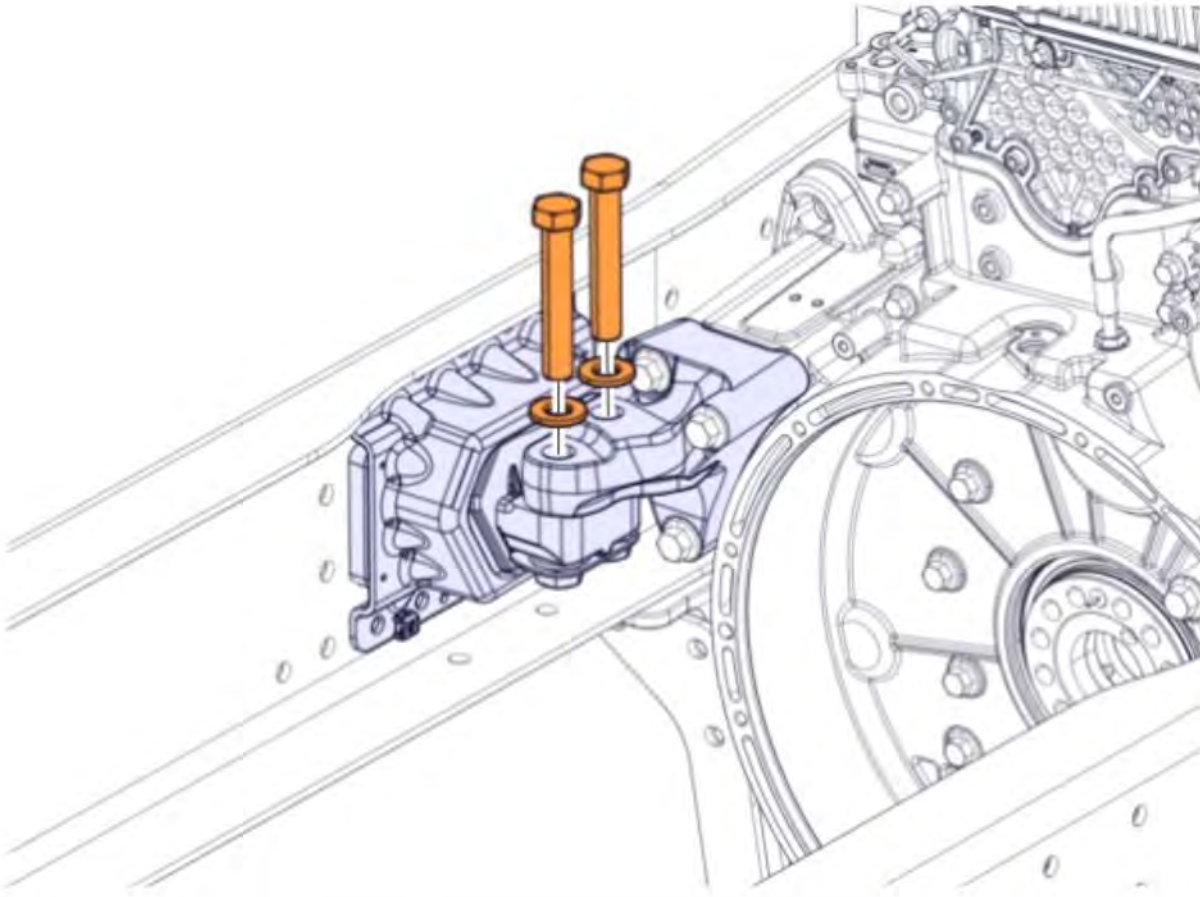

149 Remove the screws.

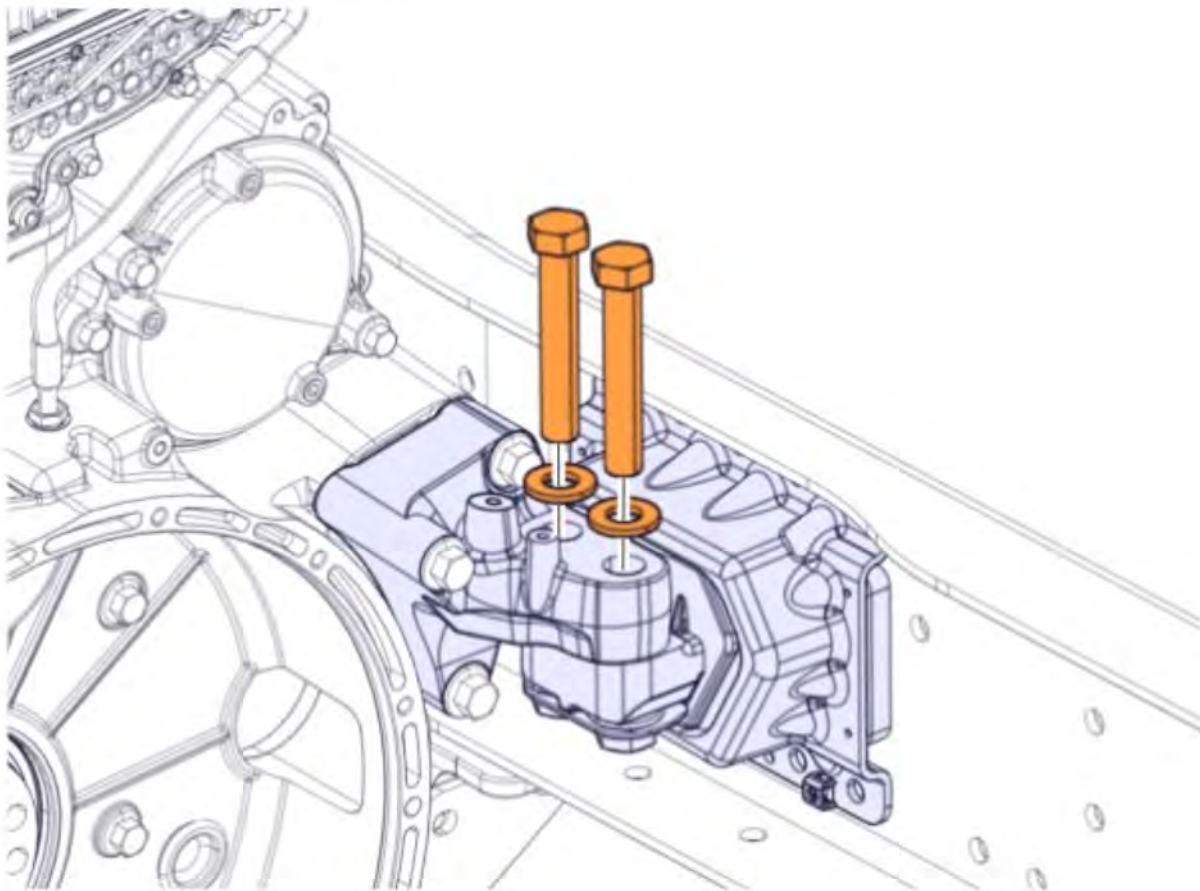

	CAUTION
---	----------------

Risk of serious injury.
Heavy component.

▶ Exercise caution when moving the component. Use appropriate tools.

150 Safely lift and support the engine.

151 Remove the nuts.

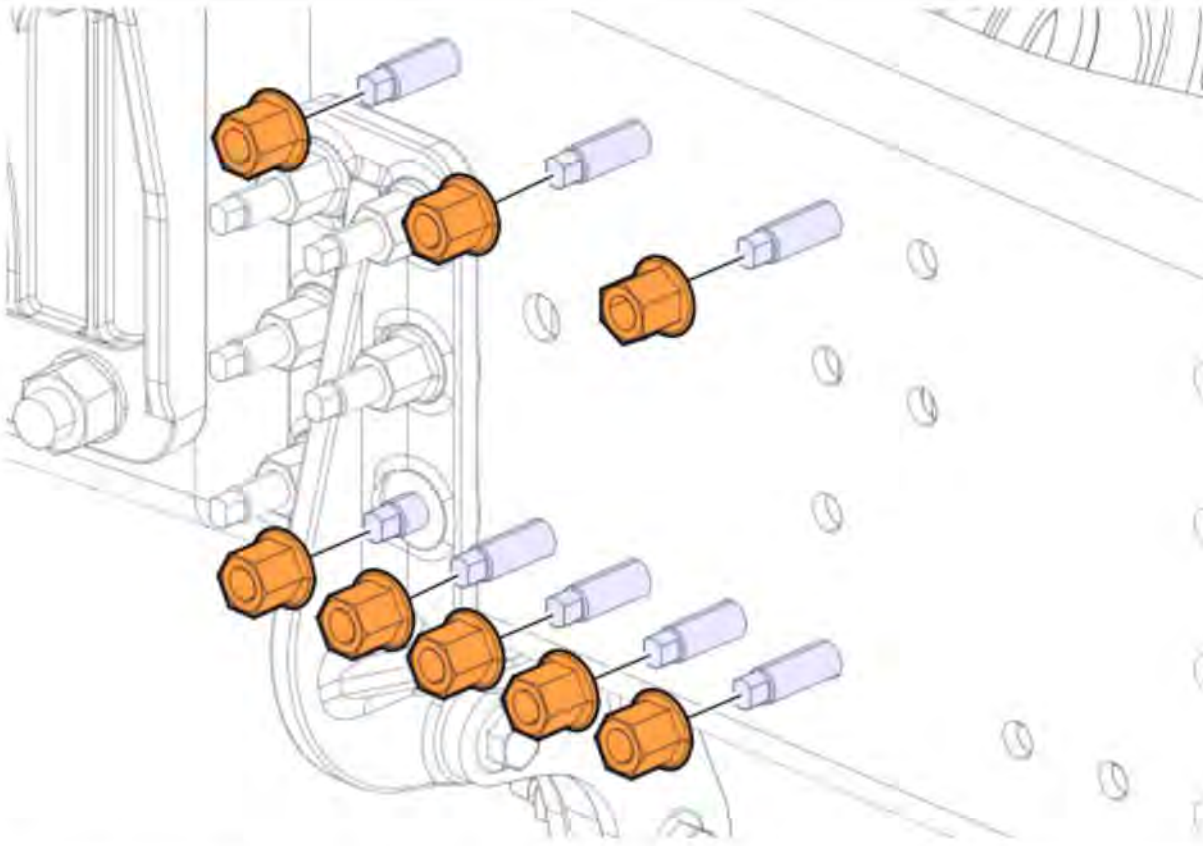

152 Perform this procedure when the condition below is met.

Conditions

- If the screw has a non-removable nut

▶ Cut the nut to remove it.

153 Remove the screws.

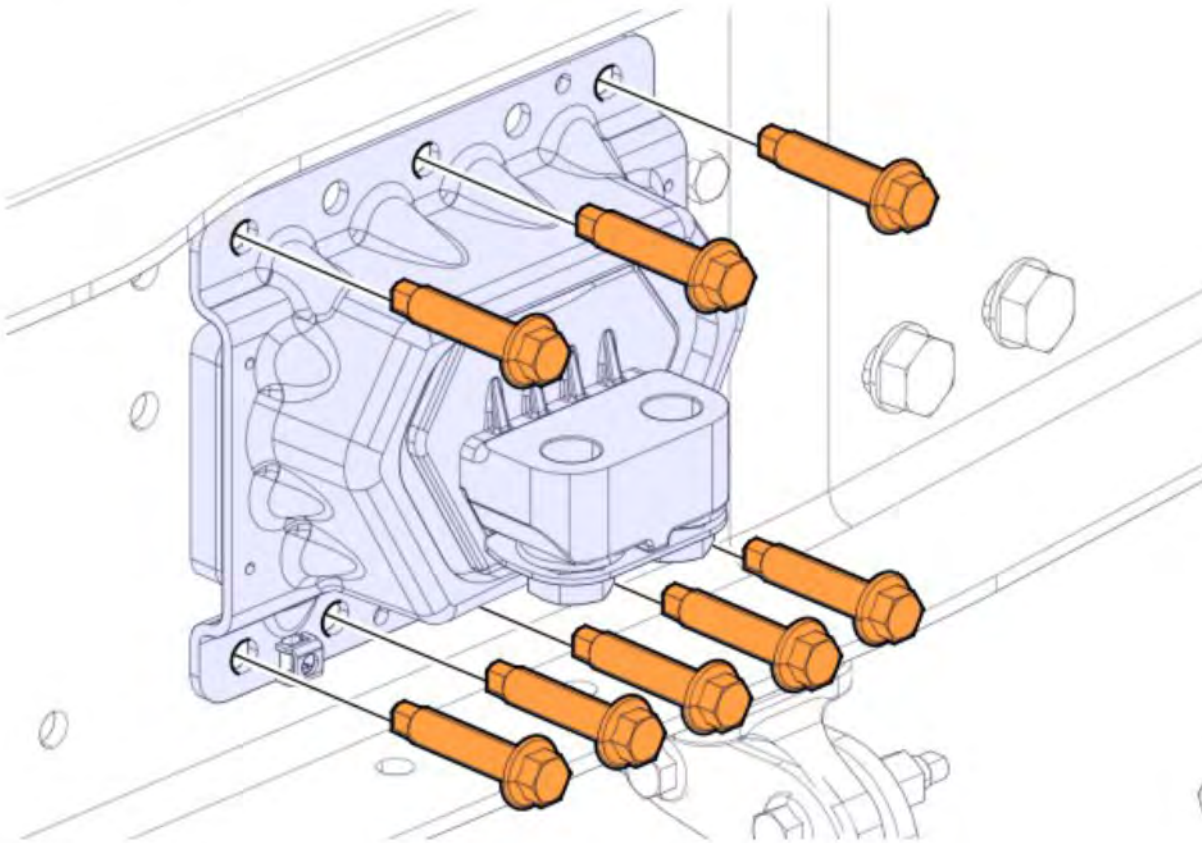

154 Remove the rubber cushion.

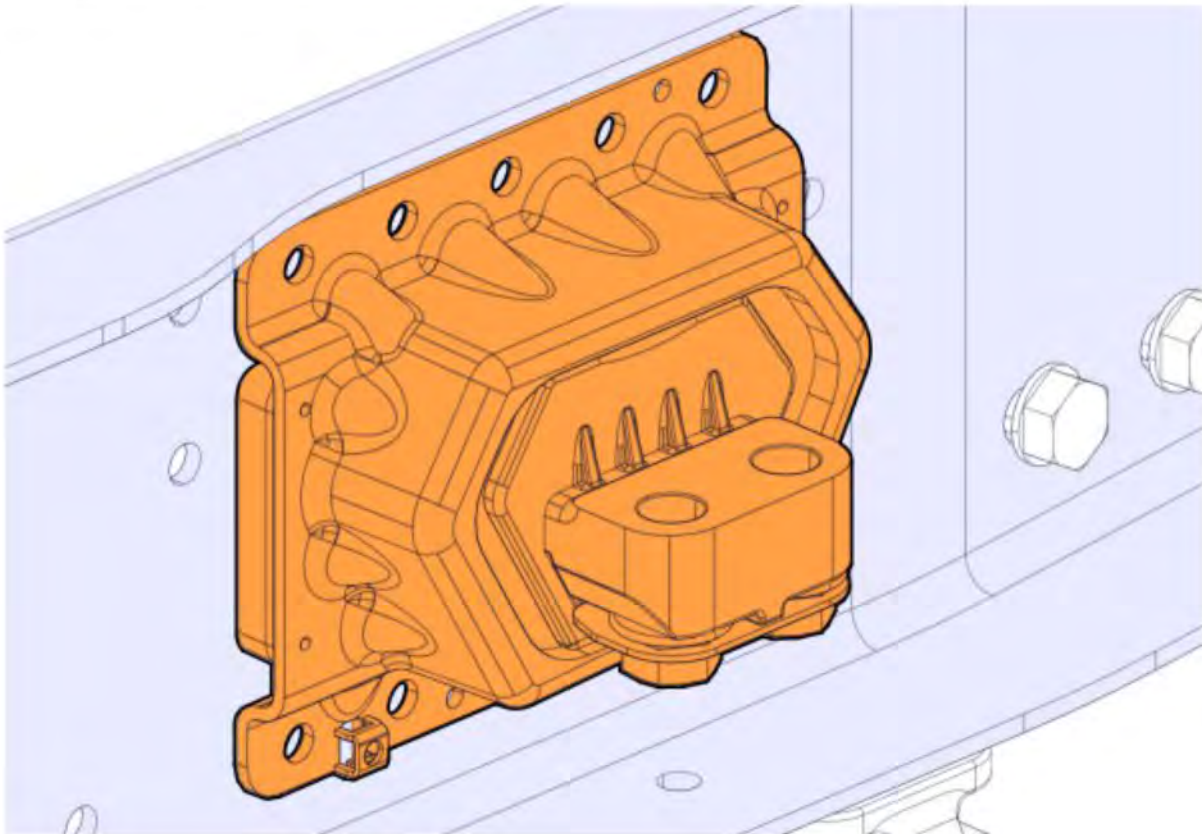

155 Remove the nuts.

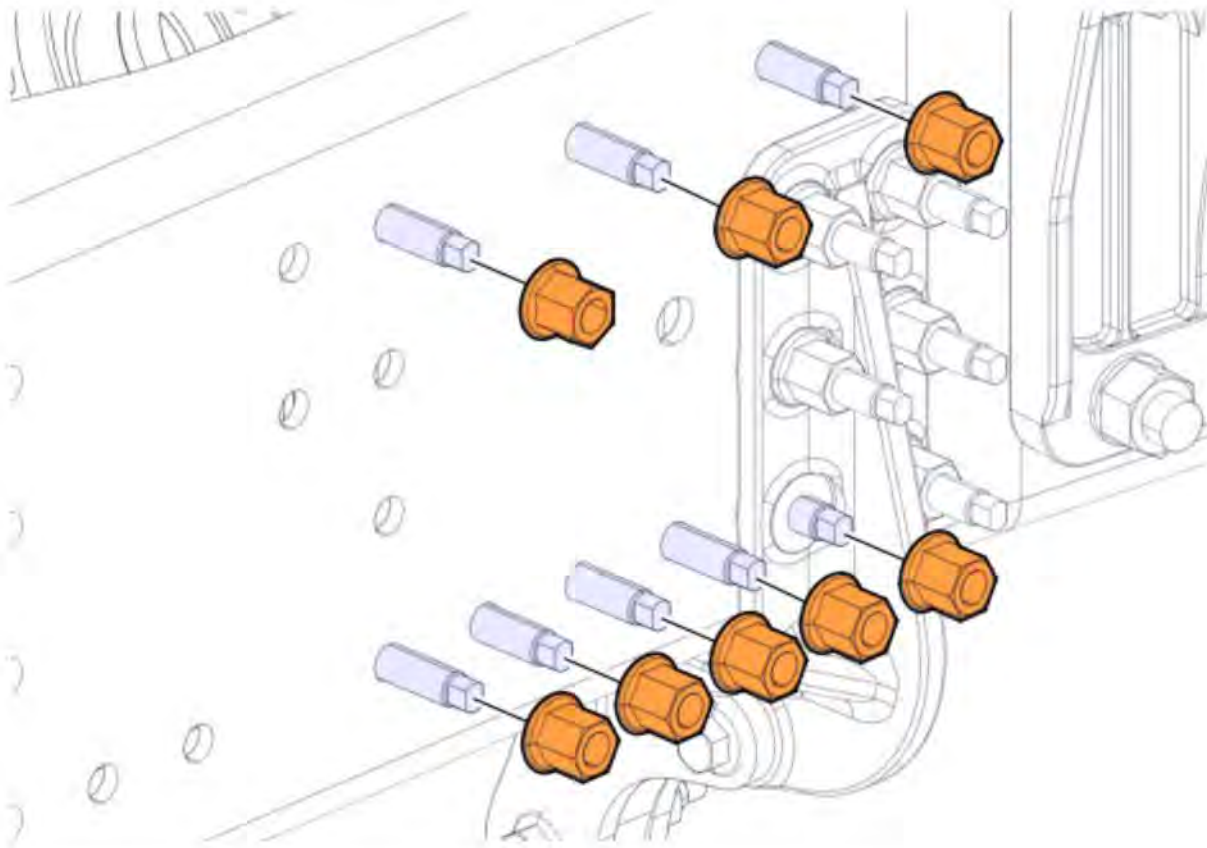

156	Perform this procedure when the condition below is met.
	Conditions
	<ul style="list-style-type: none"> • If the screw has a non-removable nut
	<ul style="list-style-type: none"> ▶ Cut the nut to remove it.
	<ul style="list-style-type: none"> ▶ Remove the screws.

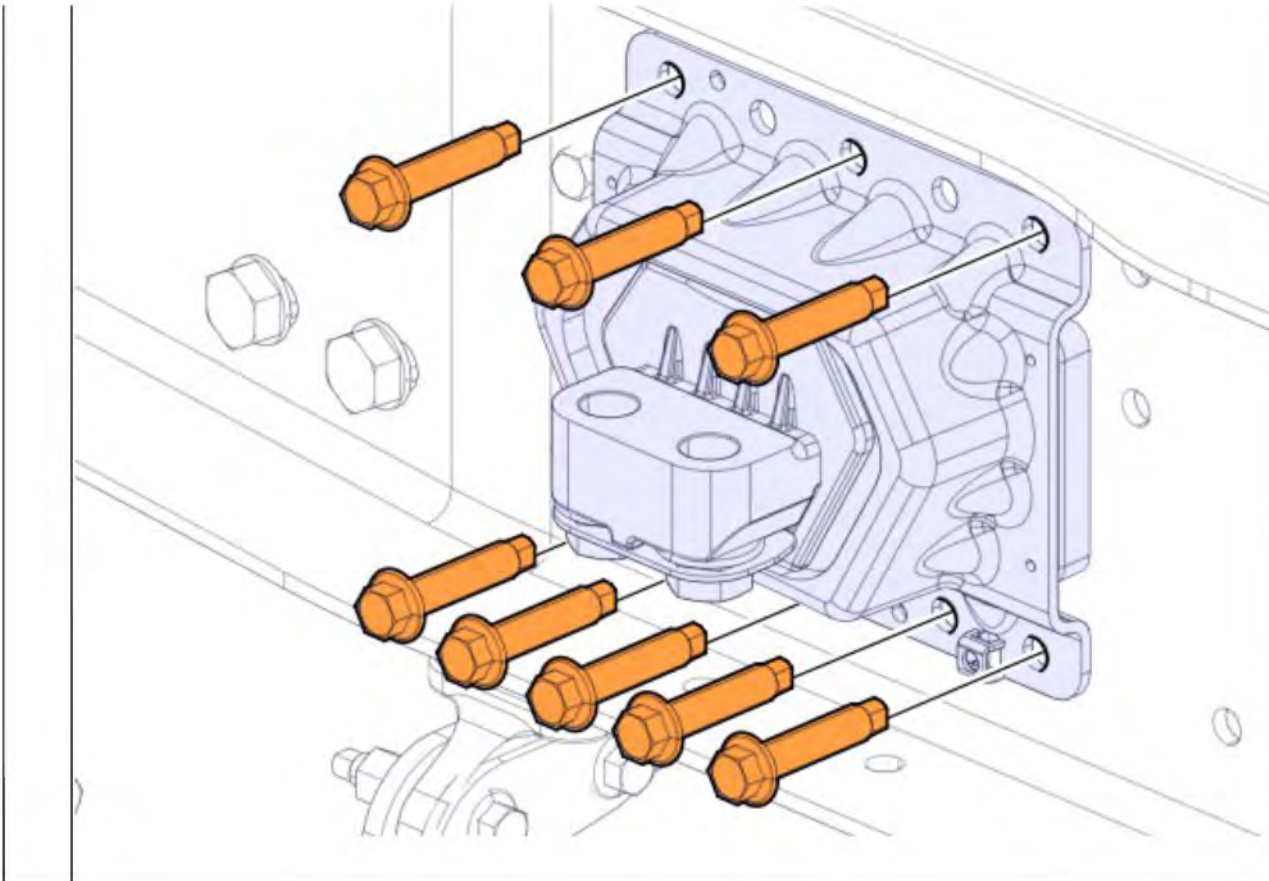

157 Remove the rubber cushion.

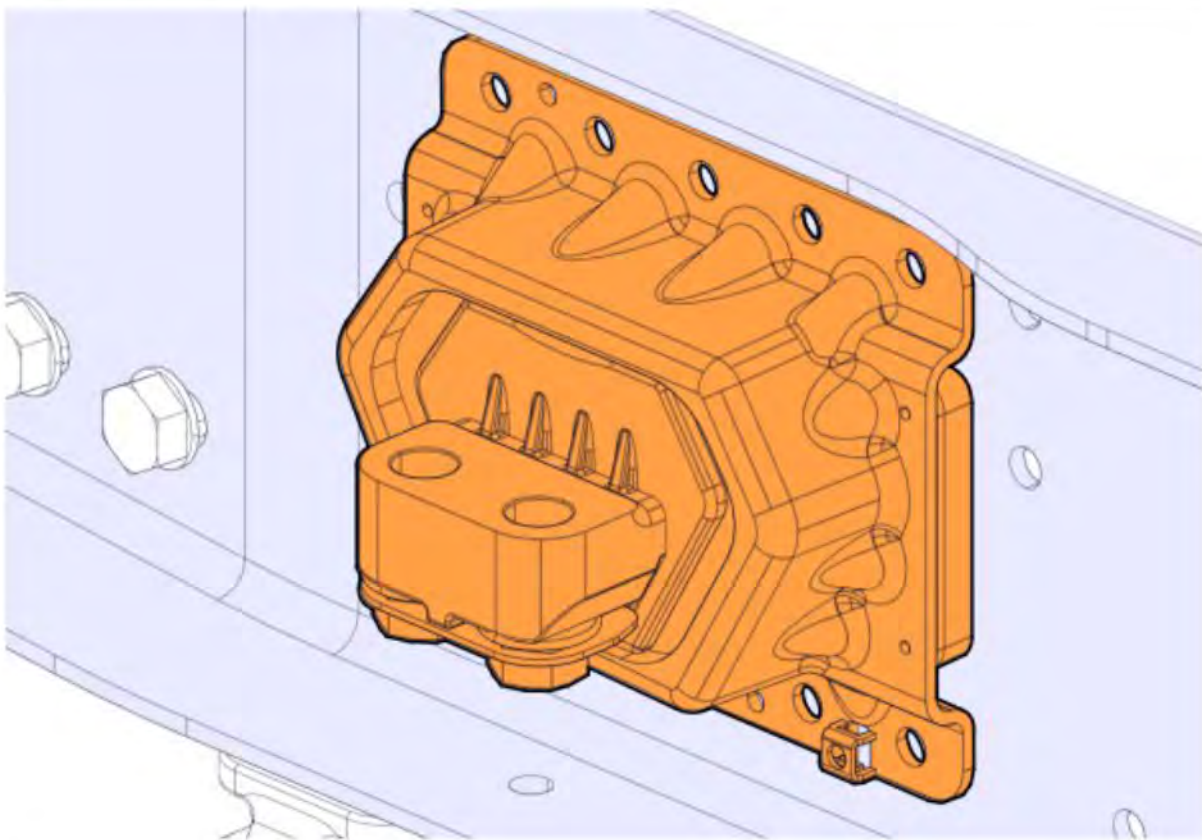

158 Remove the nut and screw.

159 Remove the screw.

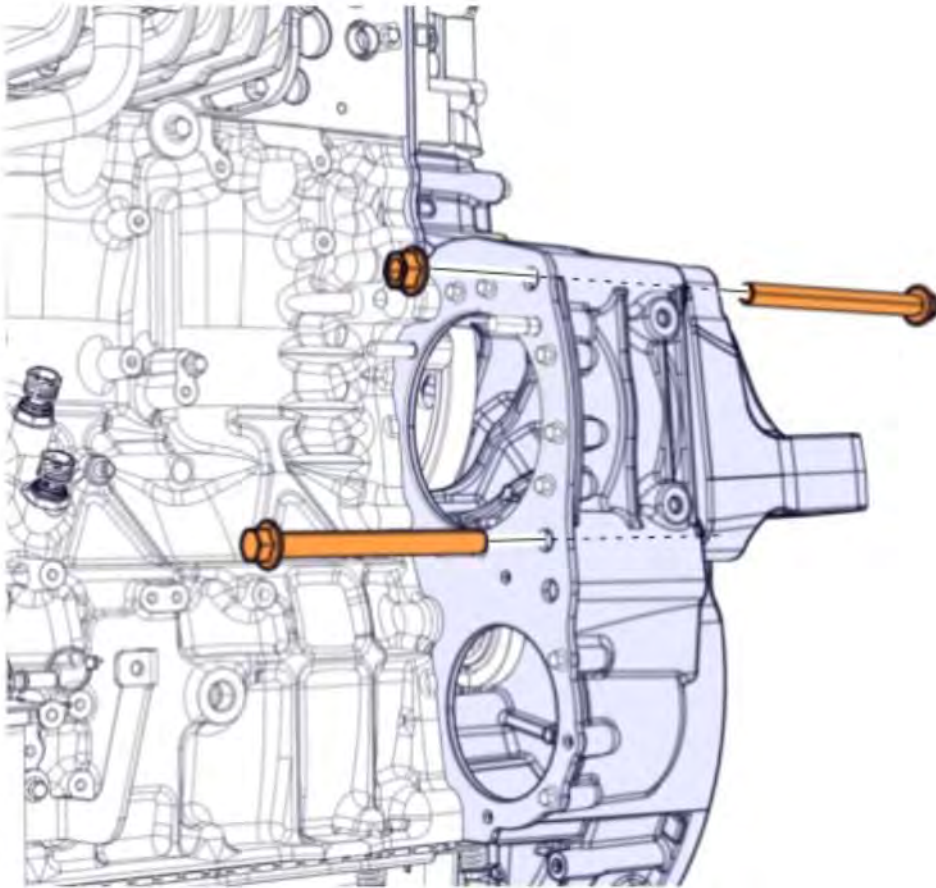

160	Remove the screw.
-----	-------------------

161	Remove the bracket.
-----	---------------------

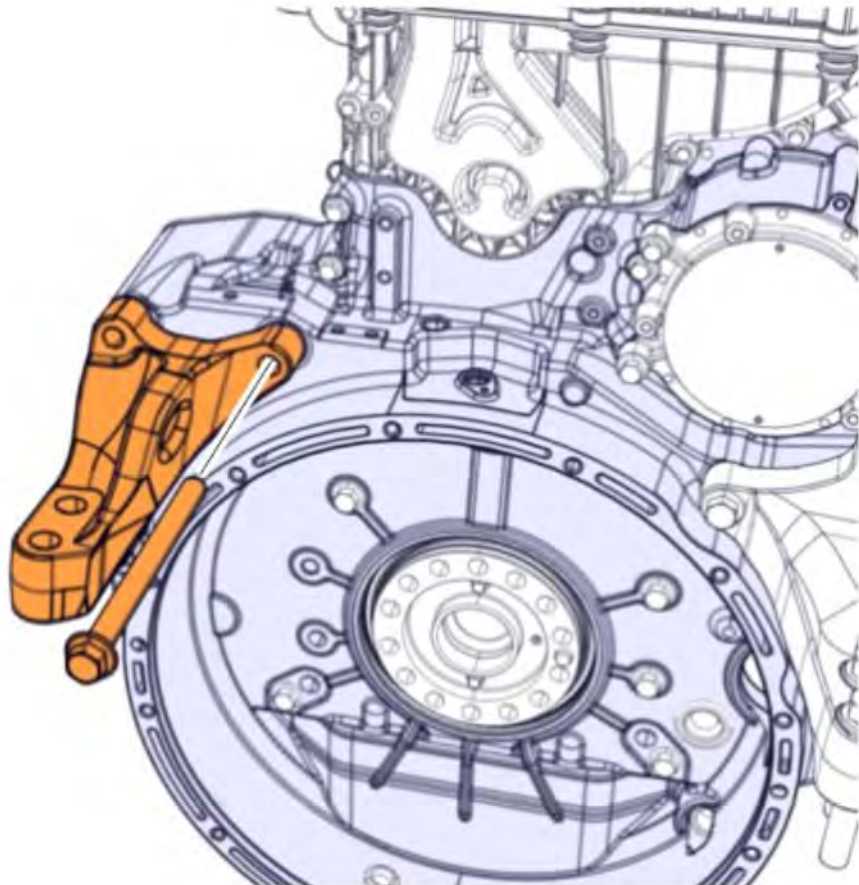

162	Remove the nut and screw.
-----	---------------------------

163	Remove the screw.
-----	-------------------

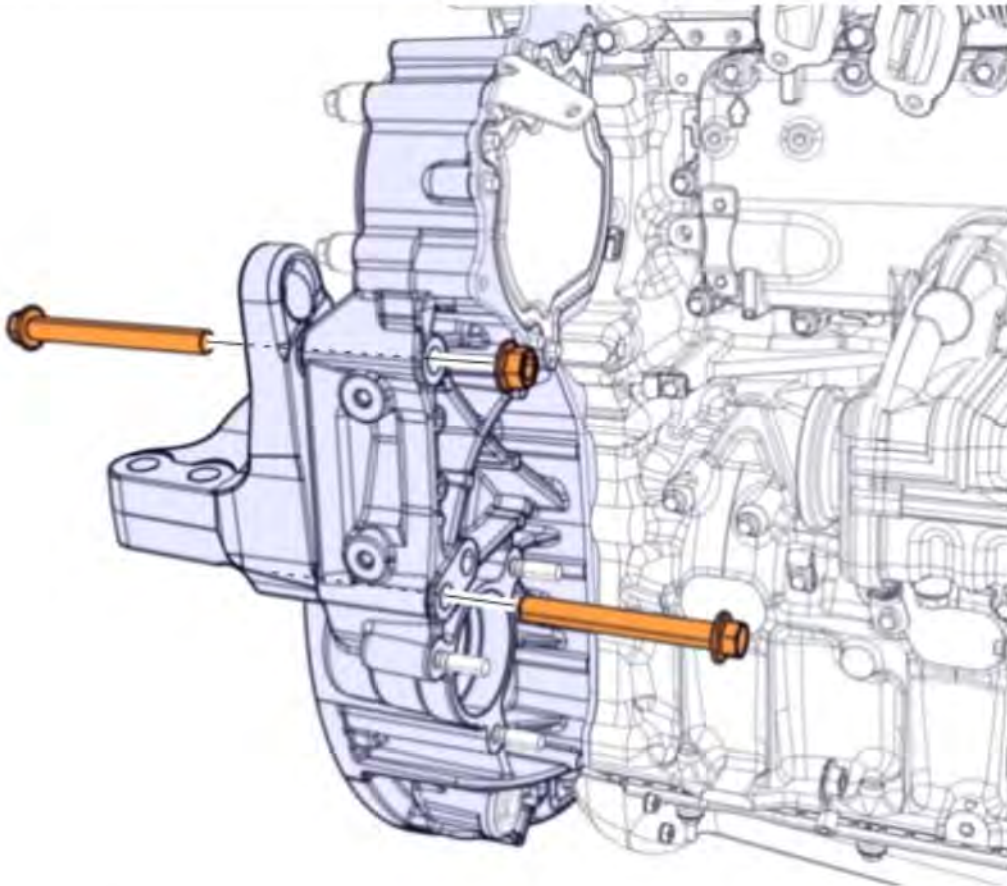

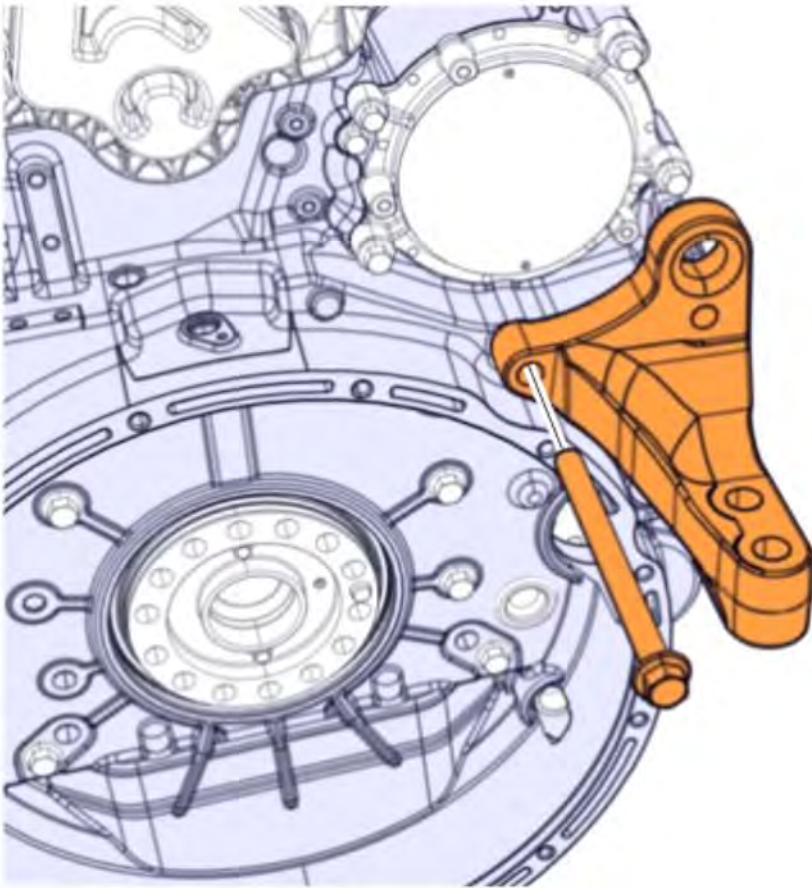

164	Remove the screw.
-----	-------------------

165	Remove the bracket.
-----	---------------------

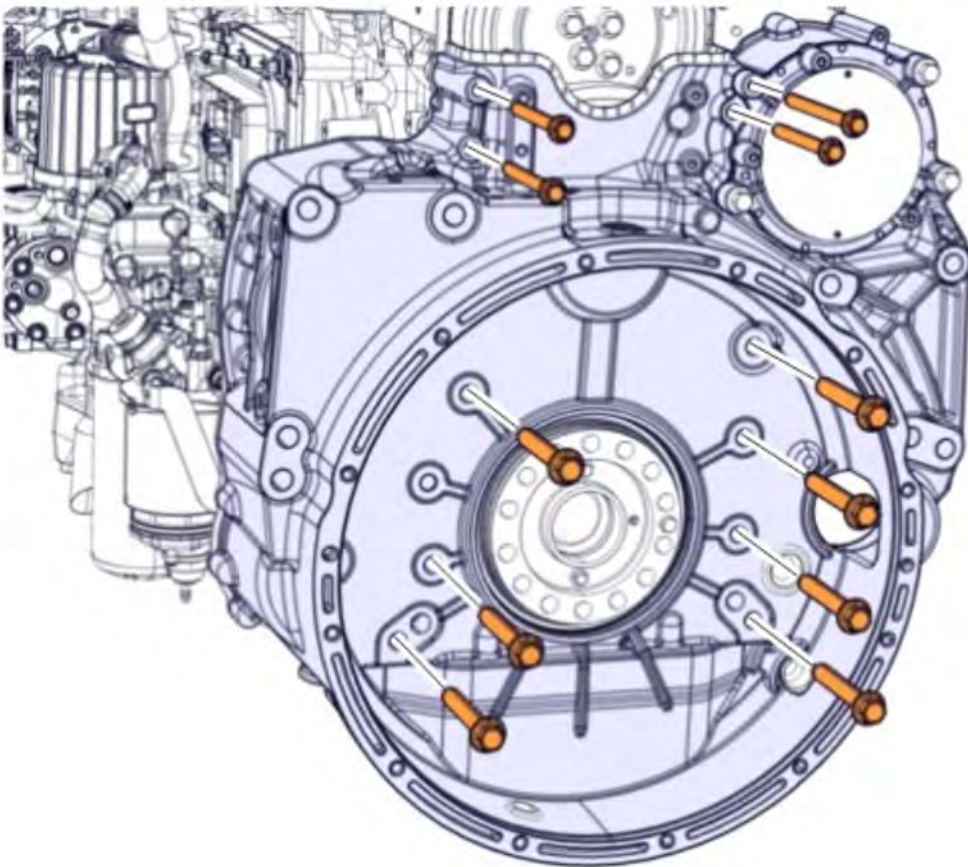

166 Remove the screws.



 CAUTION
--

Risk of serious injury.
Heavy component.

▶ Exercise caution when moving the component. Use appropriate tools.

167	Remove the flywheel housing.
------------	------------------------------

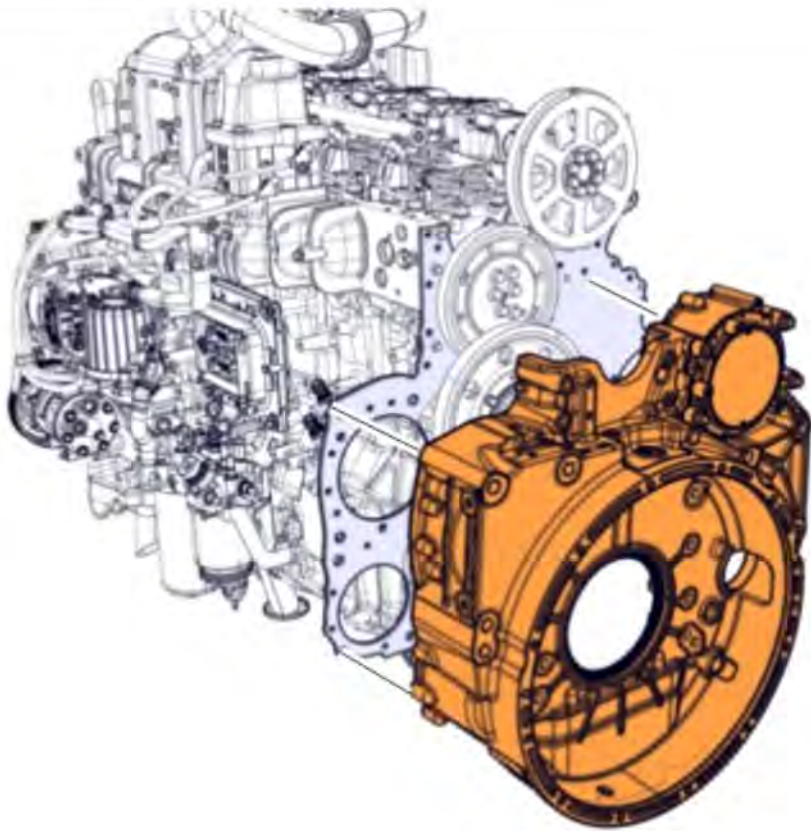

168	Remove the screw.
------------	-------------------

169	Remove the gear.
------------	------------------



Service hint
The gear may be stuck in the timing gear plate. Loosely reinstall the fastener and use a suitable puller.

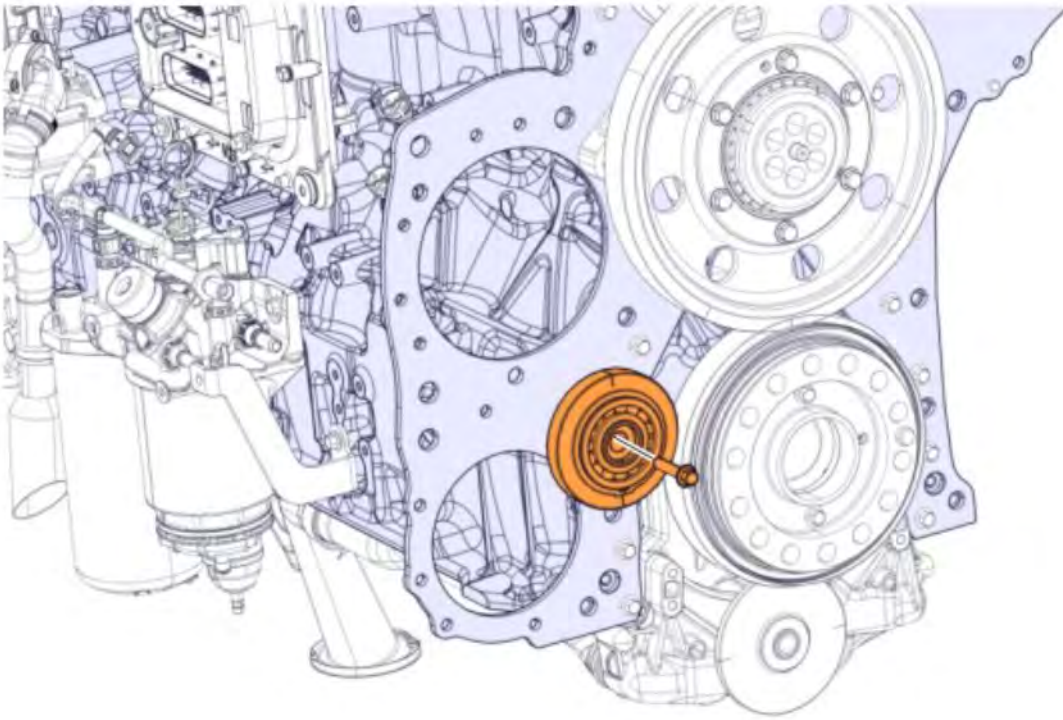

170 Check that the timing marks are at TDC.

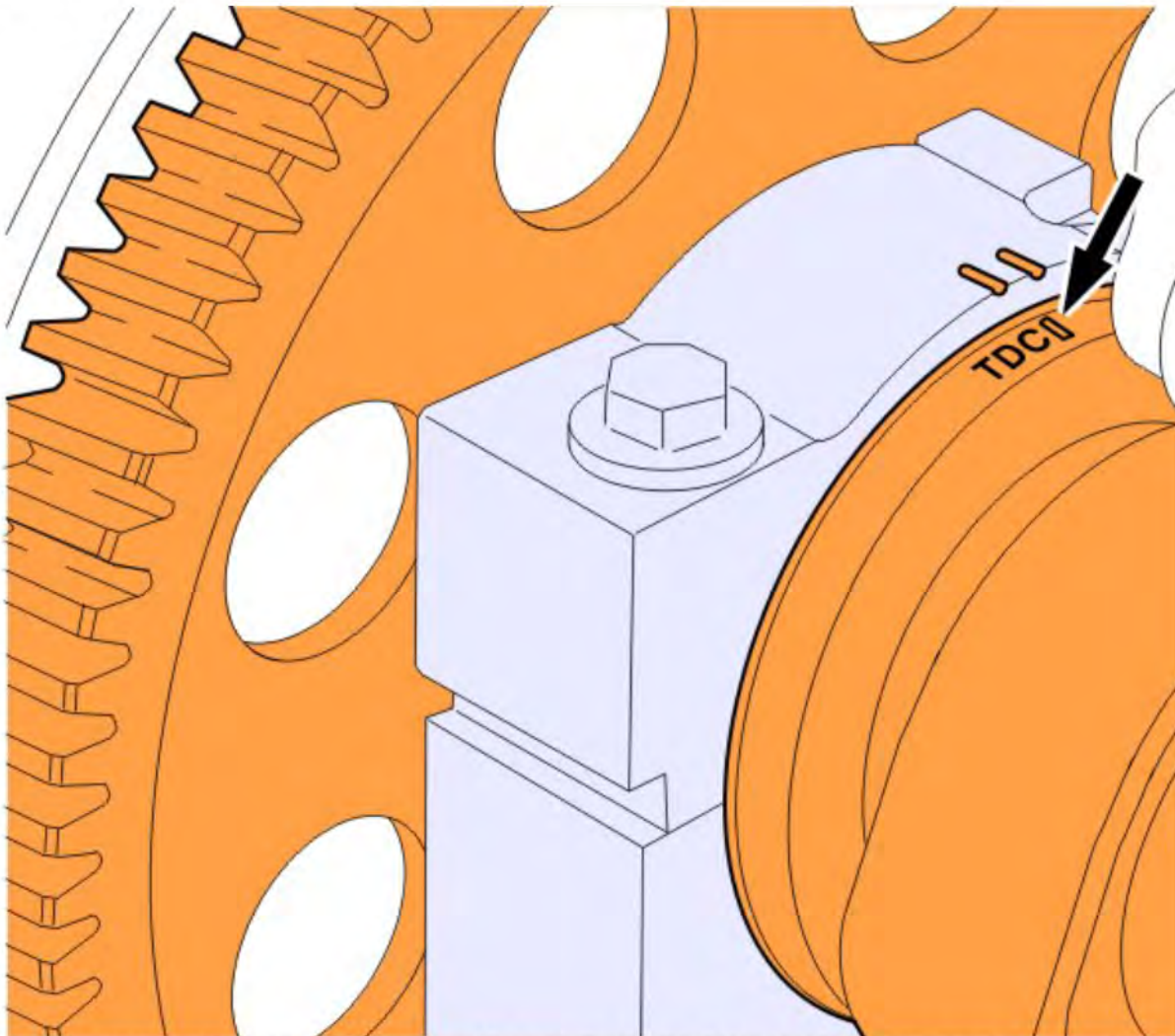

Copyright to this documentation belongs to the Volvo Group. No reproduction, copying, change, amendment or other similar disposal is entitled without prior written consent by the Volvo Group

The information contained herein is current at the time of its original distribution, but is subject to change. The reader is advised that printed copies are uncontrolled.

171 Mark the gears for reference.

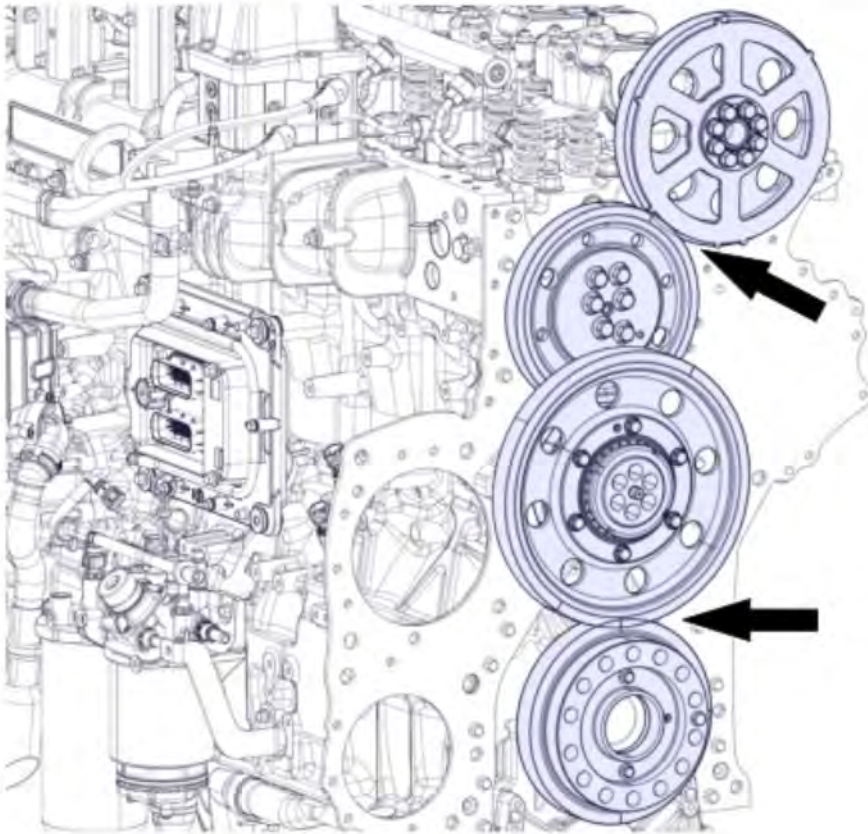

172 Remove the screws.

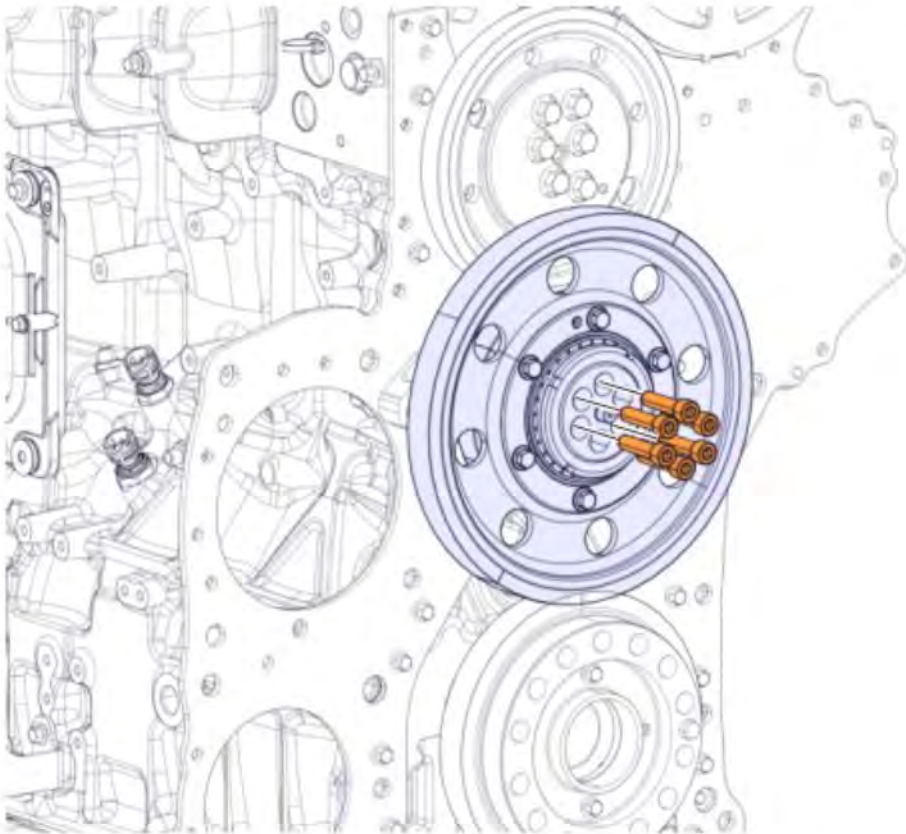

173 Remove the gears.

Copyright to this documentation belongs to the Volvo Group. No reproduction, copying, change, amendment or other similar disposal is entitled without prior written consent by the Volvo Group

The information contained herein is current at the time of its original distribution, but is subject to change. The reader is advised that printed copies are uncontrolled.

**Note**

Do not separate the gears.

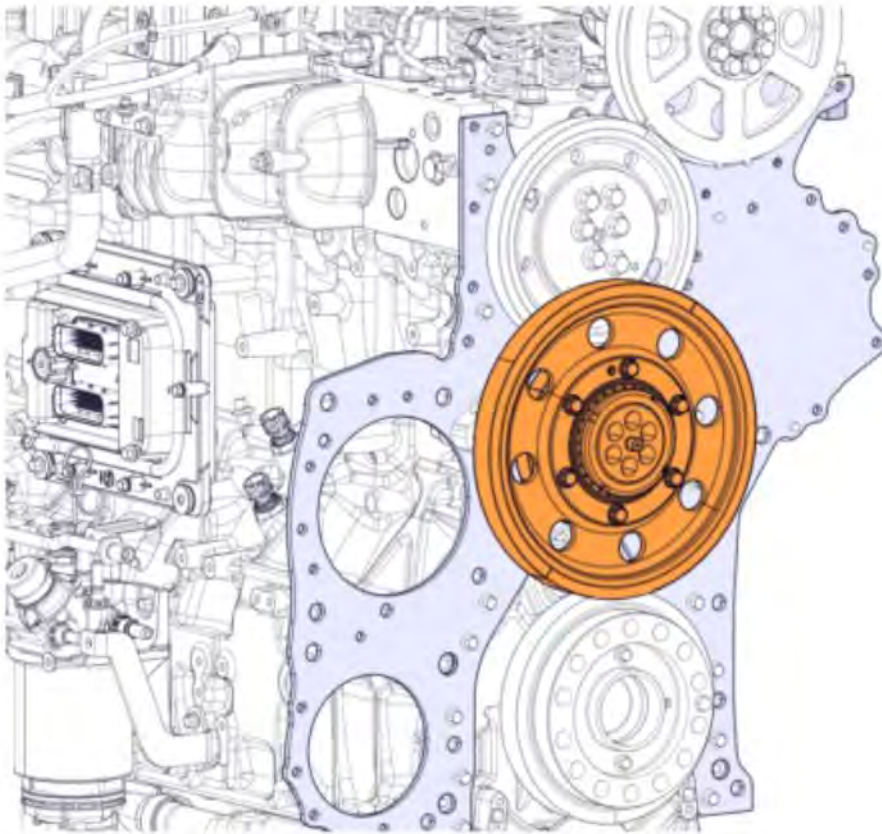

174 Remove the screws and the tone wheel.

**Note**

Discard the screws.

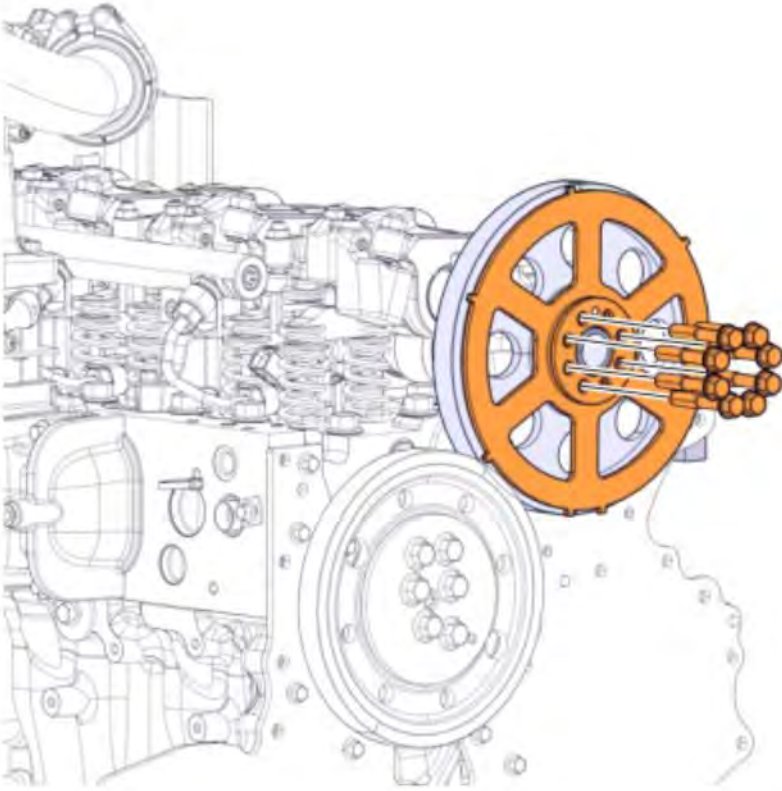

175 Remove the gear.

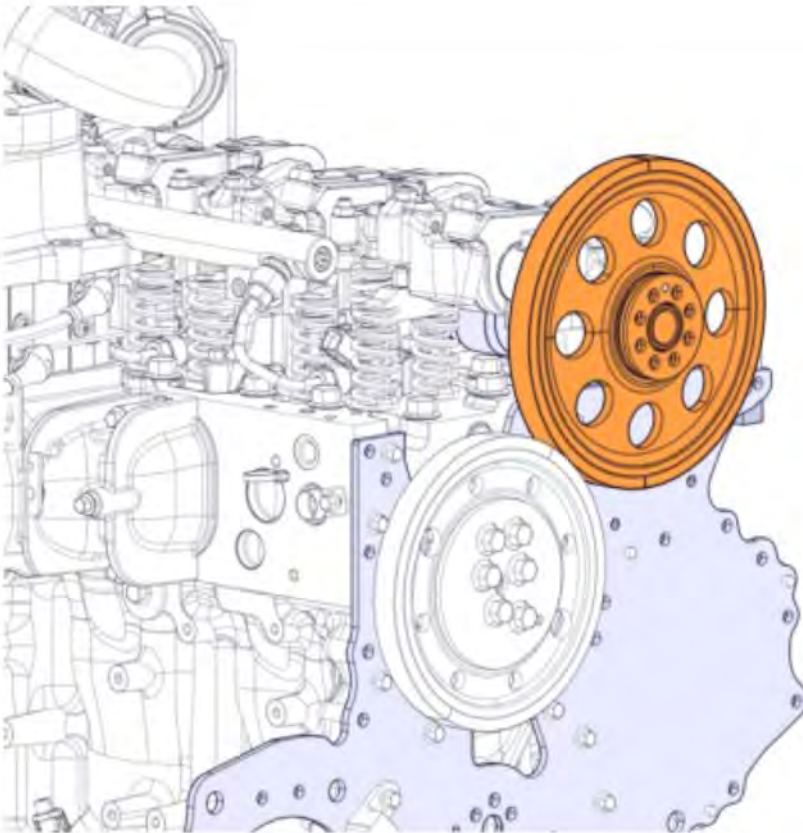

CAUTION

Copyright to this documentation belongs to the Volvo Group. No reproduction, copying, change, amendment or other similar disposal is entitled without prior written consent by the Volvo Group

The information contained herein is current at the time of its original distribution, but is subject to change. The reader is advised that printed copies are uncontrolled.

Risk of material damage.

The idler gear can be damaged if mishandled.

- ▶ Take care while removing the idler gear screws.
- ▶ Secure the idler gear while removing the idler gear hub screws.

176 Remove the screws.

177 Remove the gear.

178 Remove the thrust washer.

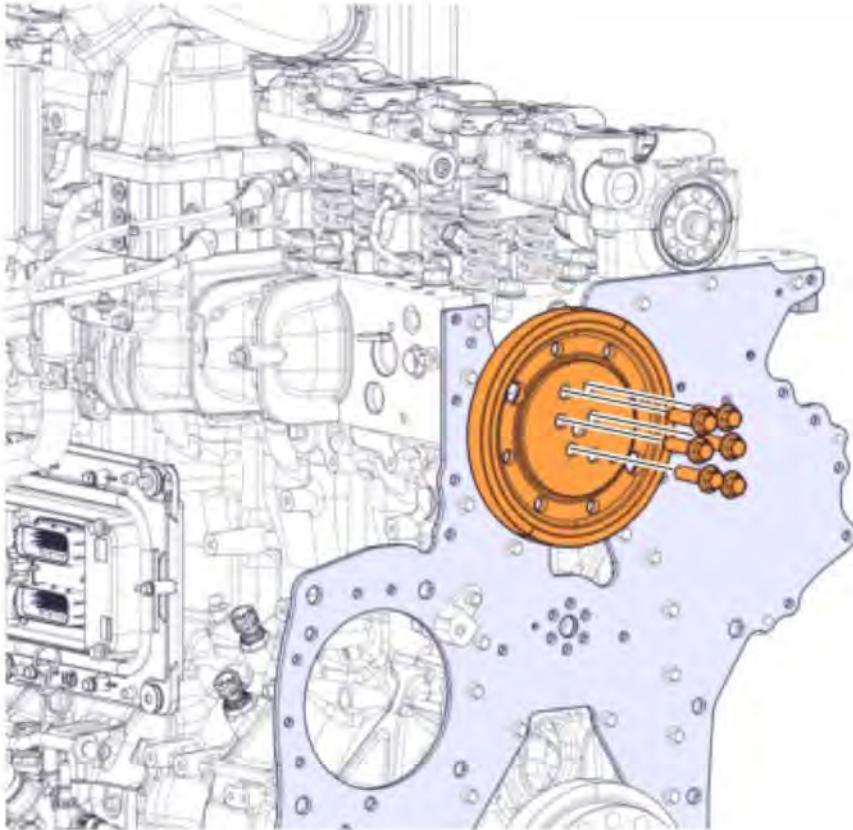

179 Remove the screws.

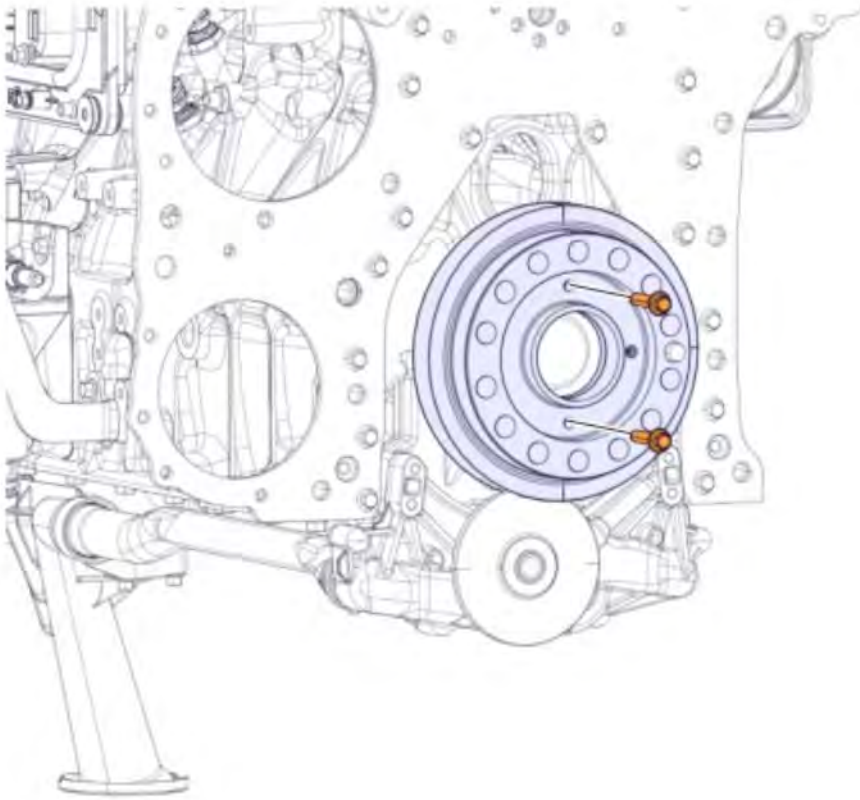

180 Remove the gear and the seal.



Note

Use a suitable tool.

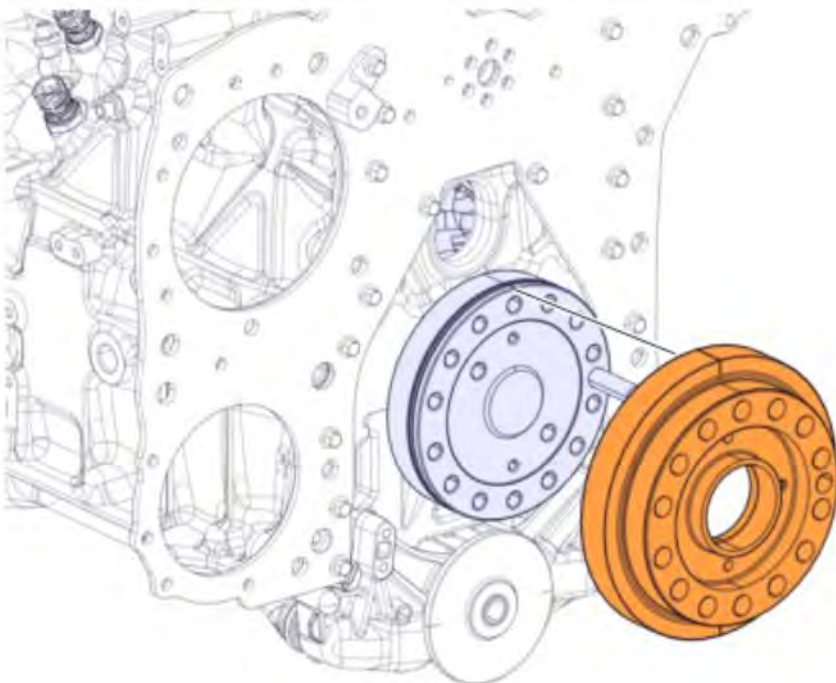

181 Clean the crankshaft.

Copyright to this documentation belongs to the Volvo Group. No reproduction, copying, change, amendment or other similar disposal is entitled without prior written consent by the Volvo Group

The information contained herein is current at the time of its original distribution, but is subject to change. The reader is advised that printed copies are uncontrolled.

182	Install the seal.		
	<table border="1" style="width: 100%;"> <tr> <td style="width: 20px; text-align: center;">i</td> <td>Note Use a new part.</td> </tr> </table>	i	Note Use a new part.
i	Note Use a new part.		

183	Lubricate the gear contact surface.		
	<table border="1" style="width: 100%;"> <tr> <td style="width: 20px; text-align: center;">i</td> <td>Note Use recommended lubricant.</td> </tr> </table>	i	Note Use recommended lubricant.
i	Note Use recommended lubricant.		

184	Install the gear.
------------	-------------------

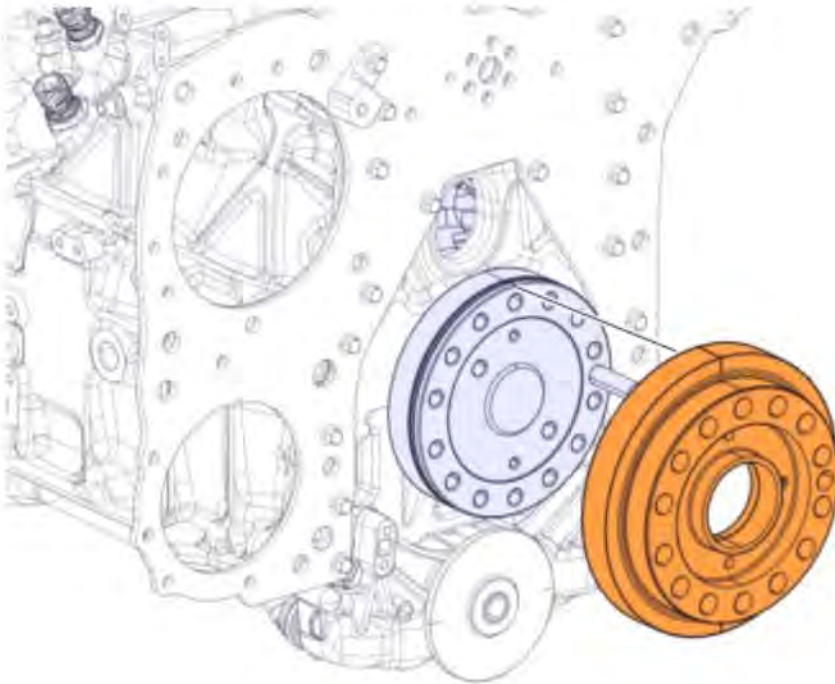

185	Install the screws.
------------	---------------------

186	Torque tighten the screws.	
	Tightening torque	
	Crankshaft gear, screw	24 ±4 Nm (18 ±3 lb _f -ft)

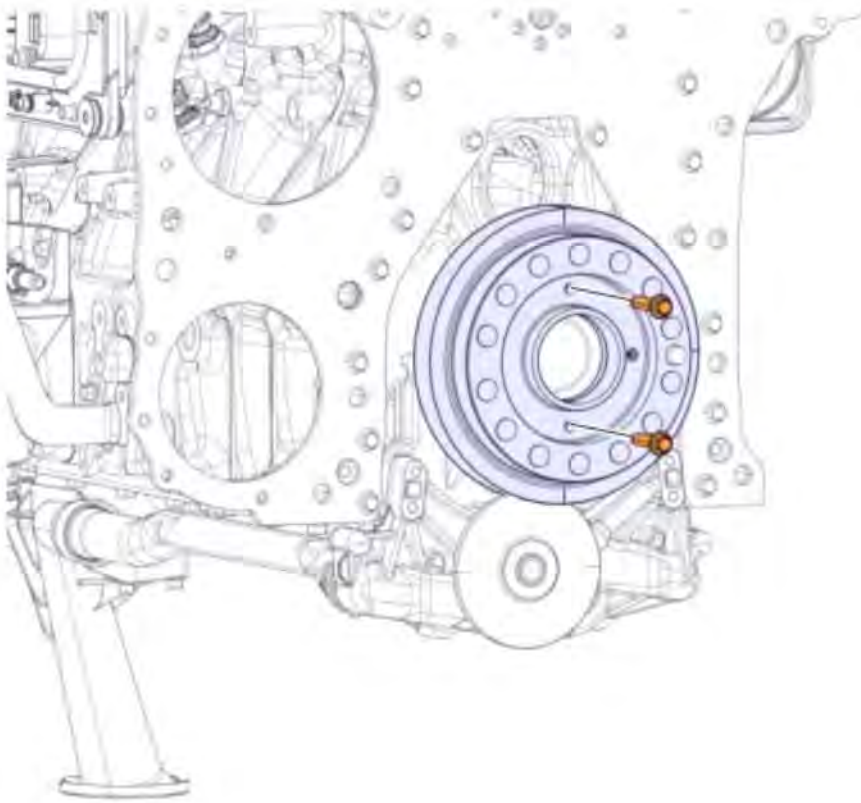

187	Install the tools.							
	Required material							
	GUIDE	9998267	2 pcs					
	<table border="1"> <tr> <td style="text-align: center;">i</td> <td>Note</td> </tr> <tr> <td colspan="2">The tools act as guides for timing gear plate alignment.</td> </tr> <tr> <td colspan="2">Do not remove the tools until the timing gear plate is installed.</td> </tr> </table>			i	Note	The tools act as guides for timing gear plate alignment.		Do not remove the tools until the timing gear plate is installed.
i	Note							
The tools act as guides for timing gear plate alignment.								
Do not remove the tools until the timing gear plate is installed.								

188	Torque tighten the screws.	
	Tightening torque	
	Timing gear plate, tool, screw	60 Nm (44 lb _f ·ft)

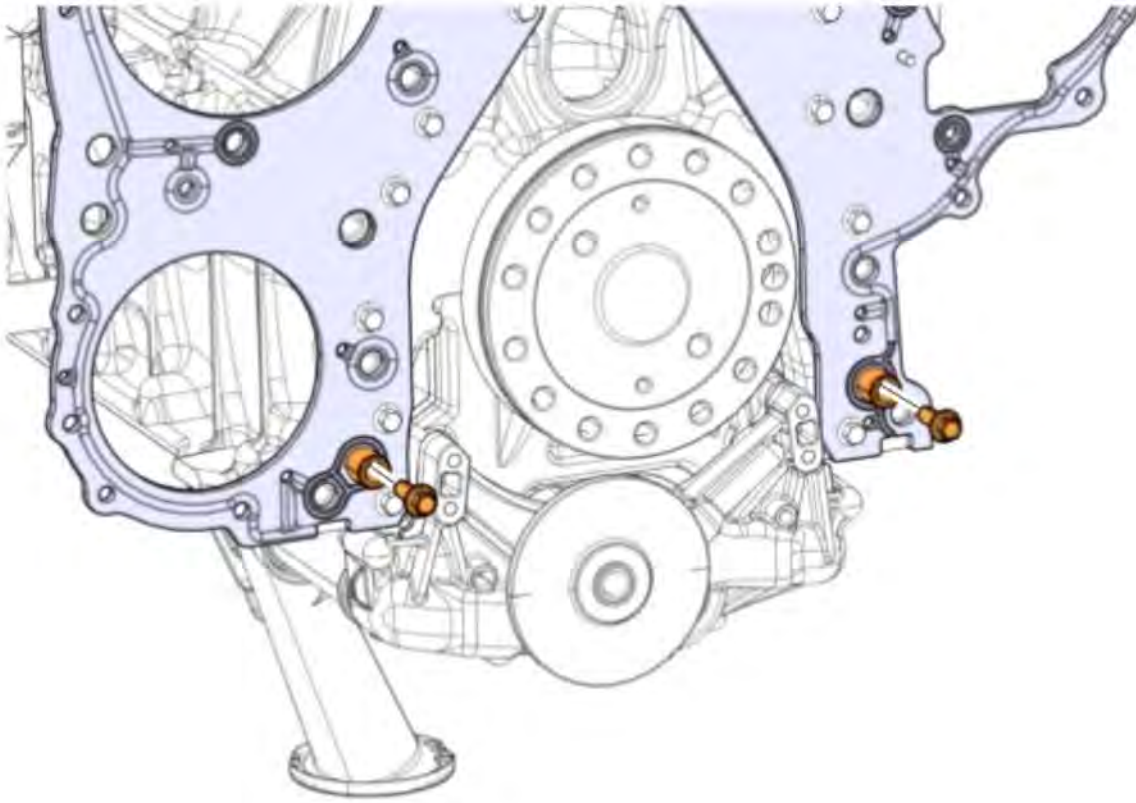

189	Remove the screw.
-----	-------------------

190	Remove the bracket.
-----	---------------------

**Note**

Discard the O-ring.

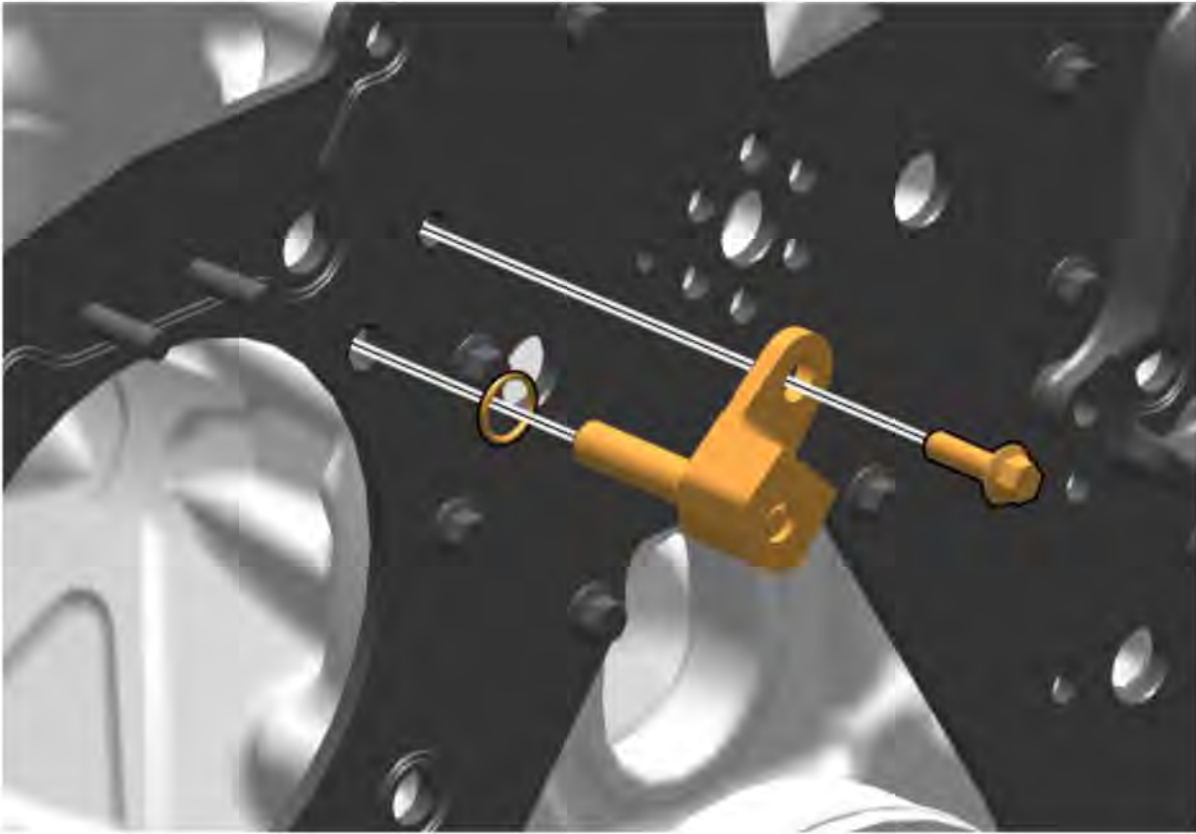
**CAUTION****Risk of serious injury.**

Heavy component.

▶ Exercise caution when moving the component. Use appropriate tools.

191 Remove the screws.

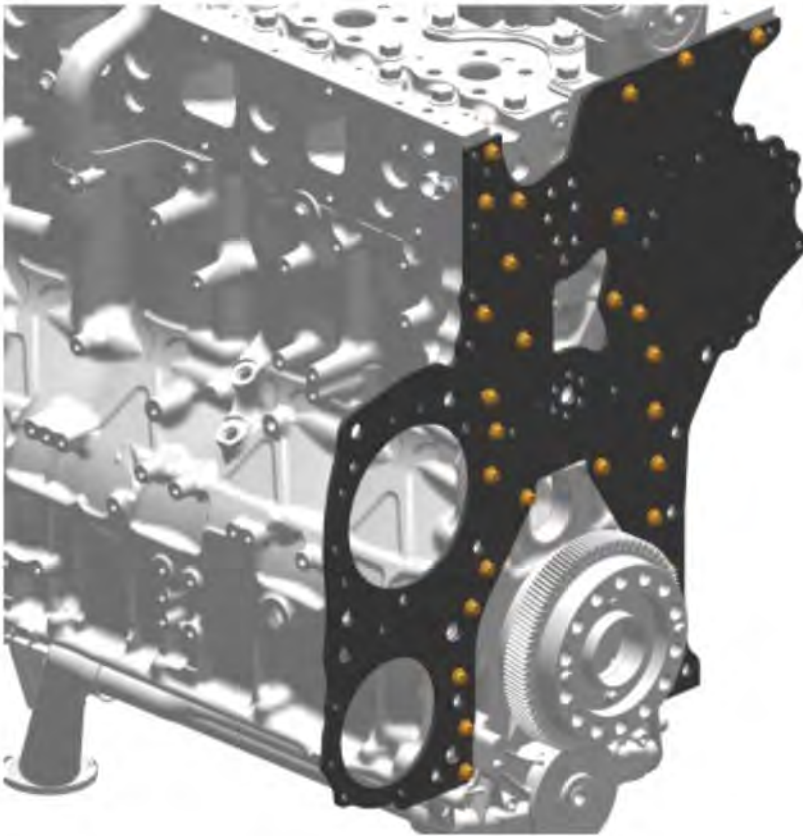

192	Remove the timing gear plate.
------------	-------------------------------

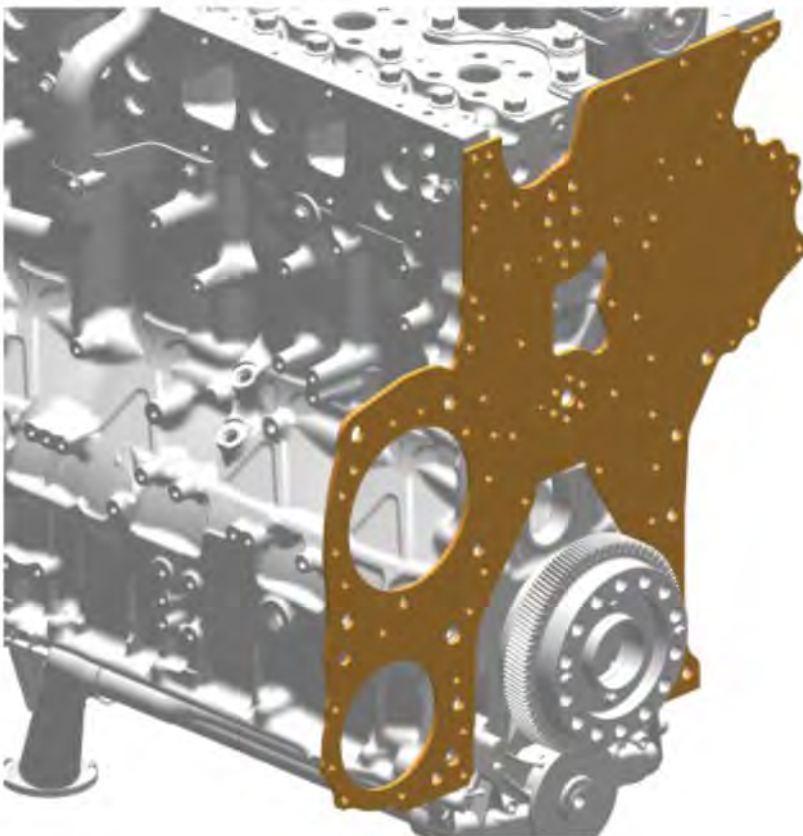

193	Remove the screws.
------------	--------------------

194	Remove the noise shield.
------------	--------------------------

[Service hint](#)



Discard the noise shield if the timing gear plate has integrated seals, because a new noise shield will come with the timing gear plate.

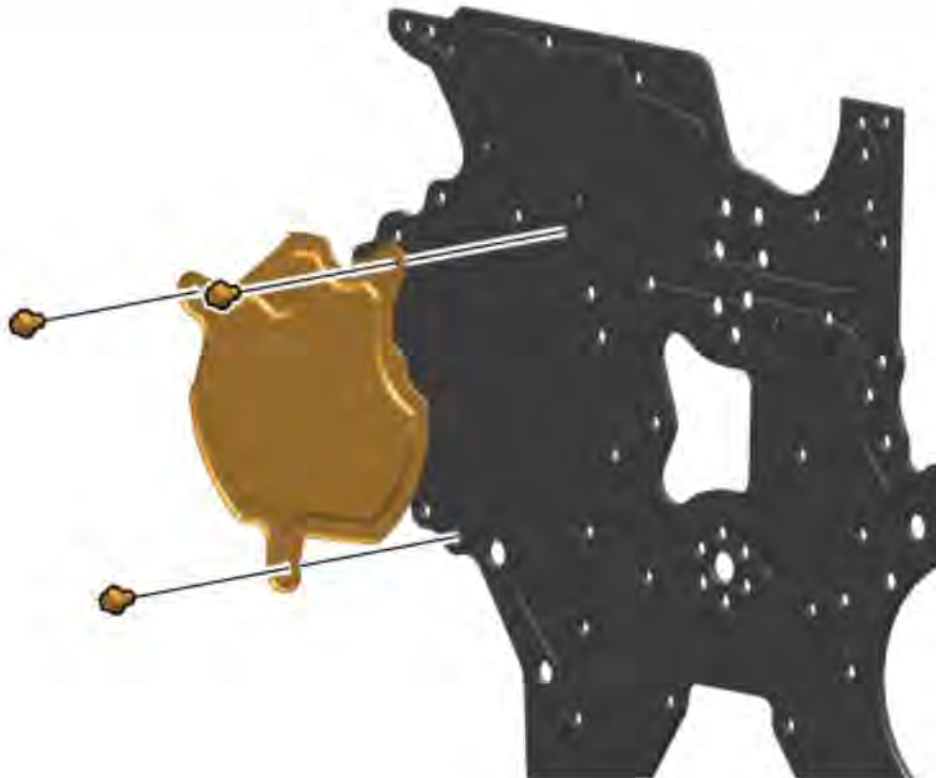

195	Perform this procedure when the condition below is met.				
Conditions					
<ul style="list-style-type: none"> If not previously installed 					
▶ Install the tools (A).					
Required material					
A	GUIDE	9998267	2 pcs		
<table border="1" style="width: 100%;"> <tr> <td style="width: 5%; text-align: center;">i</td> <td>Note Ensure that the tools are clean and damage free.</td> </tr> </table>				i	Note Ensure that the tools are clean and damage free.
i	Note Ensure that the tools are clean and damage free.				
▶ Install the screws.					
<table border="1" style="width: 100%;"> <tr> <td style="width: 5%; text-align: center;">i</td> <td>Note Hand tighten.</td> </tr> </table>				i	Note Hand tighten.
i	Note Hand tighten.				

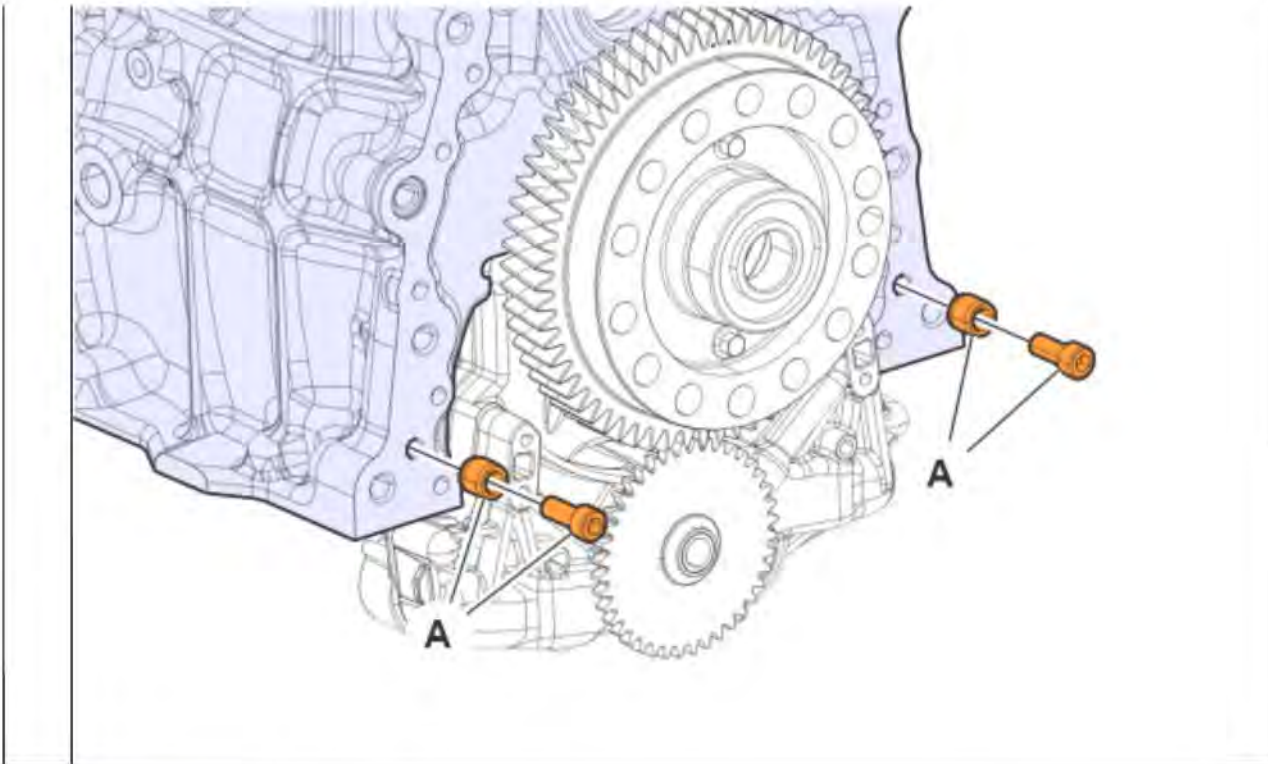

196 Install the timing gear plate.



Note

Ensure that the timing gear plate and the engine block are clean of sealant.



197 Install the screws.

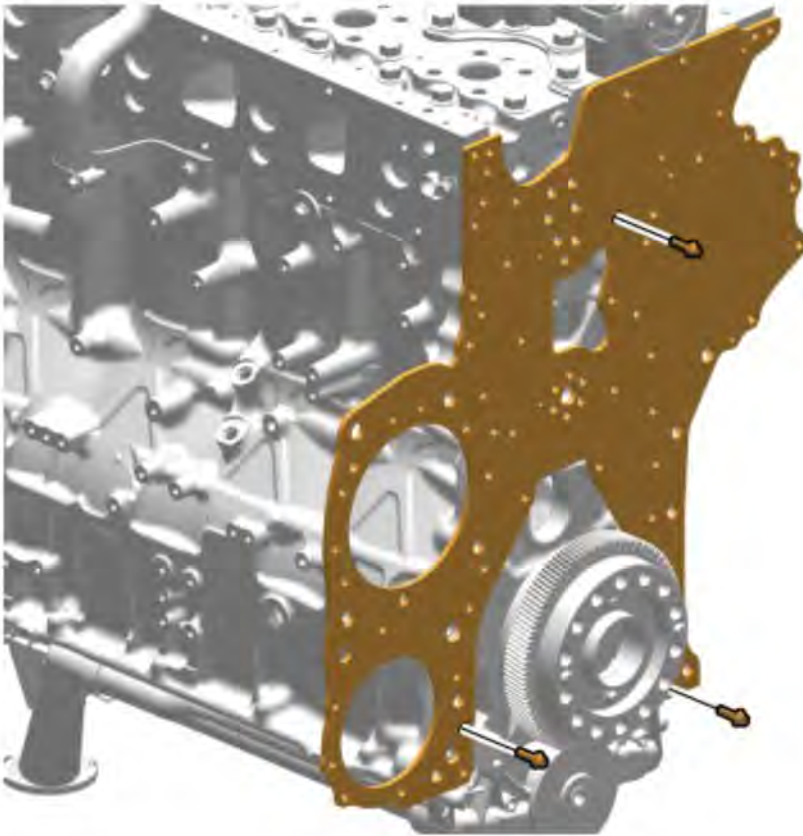

Note

Hand tighten the screws.



198	Install the gears.		
199	Install the screws. <table border="1" data-bbox="159 1086 683 1182"><tr><td data-bbox="159 1086 231 1153"></td><td data-bbox="231 1086 683 1182">Note Use a washer for the small idler gear.</td></tr></table>		Note Use a washer for the small idler gear.
	Note Use a washer for the small idler gear.		
200	Hand tighten the screws.		



201	Install the feeler gauges.	
	Tech data	
	Feeler gauge, thickness	0.1 mm (0.004 in)

202	Adjust the clearance.	
	i	Note Use a plastic mallet to adjust the timing gear plate.
	i	Note Ensure that the feeler gauges are difficult to move between the teeth.
	i	Note Ensure equal resistance on both feeler gauges.

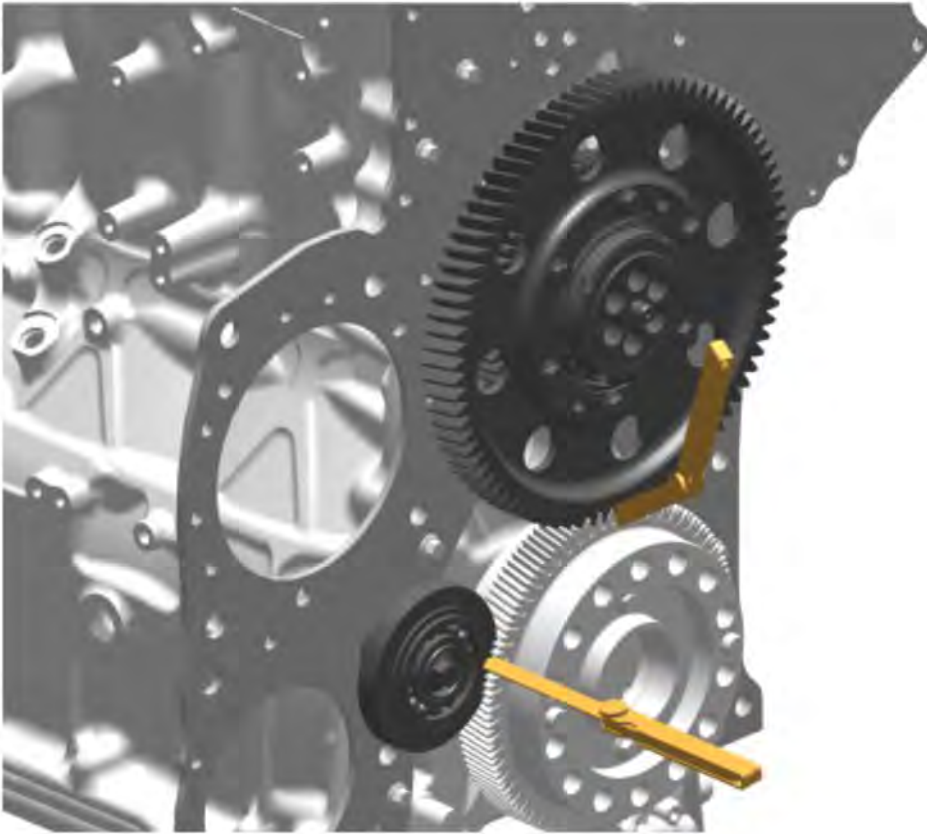

203 Tighten the screws.

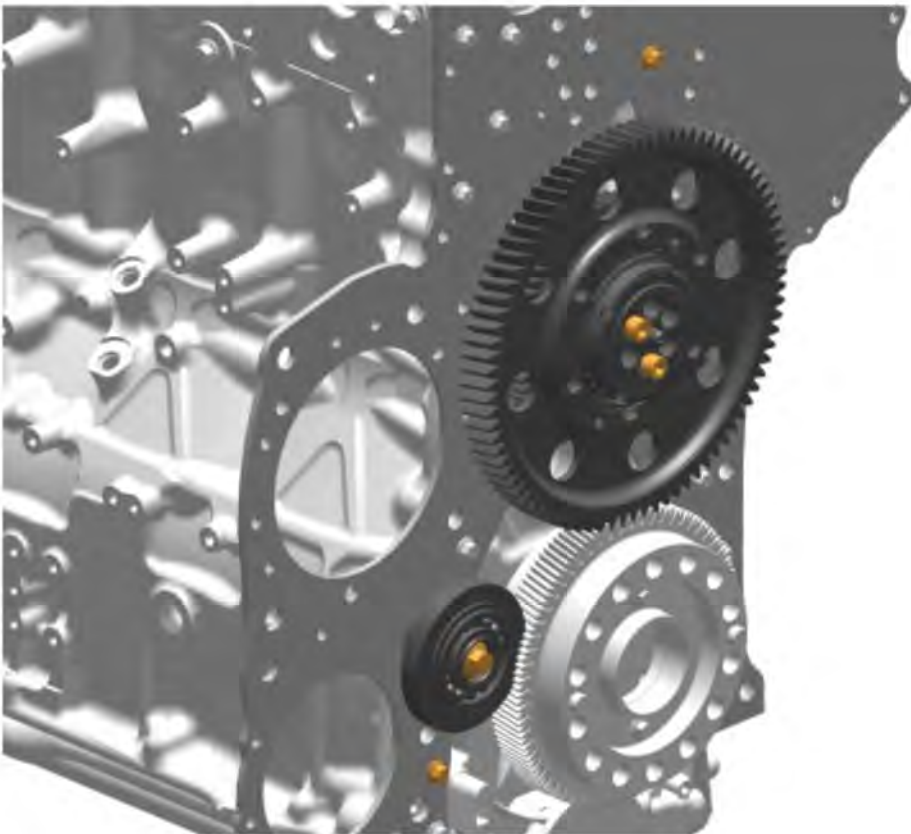

204 Place a dial indicator into position.

i **Note**
Use caution that the timing plate seal is not damaged.



Note

Ensure that the probe tip touches the gear tooth.

205 Set the dial to zero.

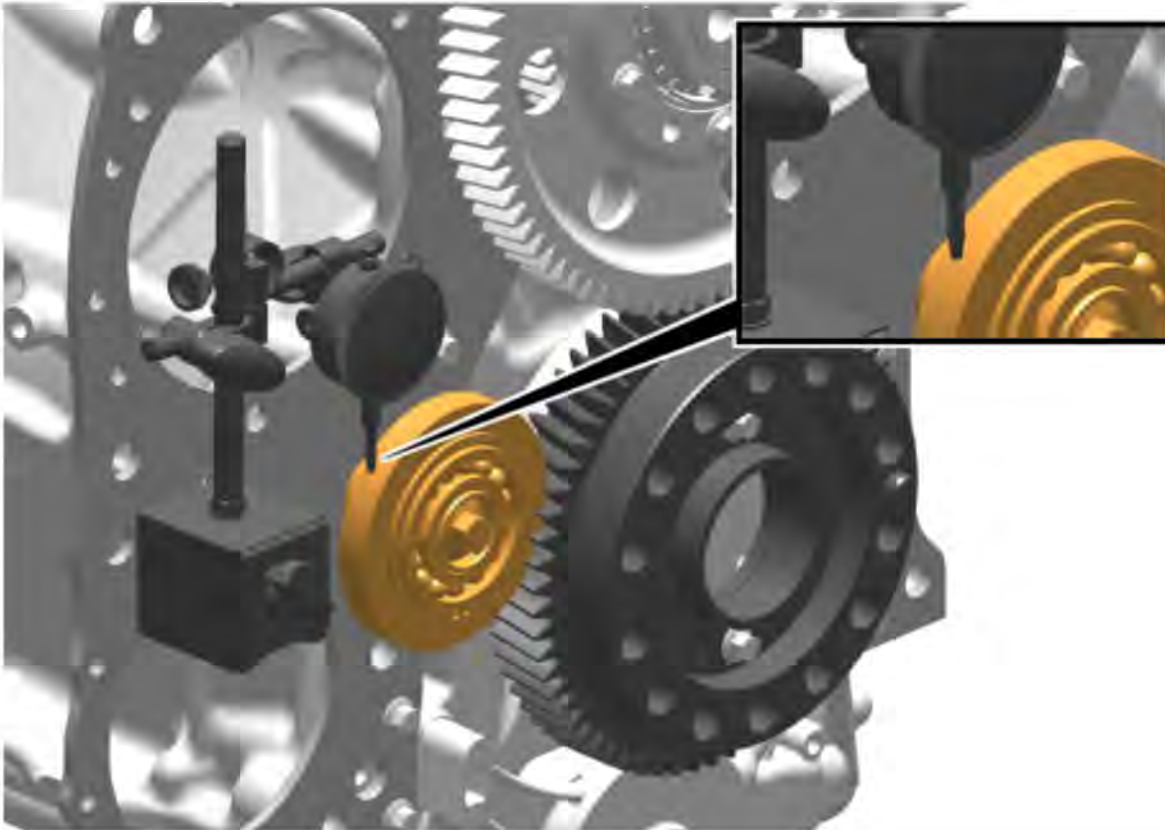

206 Turn the idler gear by hand.

207 Read and record the amount of backlash.

Tech data

Idler gear, tooth flank clearance	0.05 – 0.17 mm (0.002 – 0.0067 in)
-----------------------------------	---------------------------------------

208 Perform this procedure when the condition below is met.

Conditions

- If the backlash is out of specification
- ▶ Adjust the timing plate.

209 Install the tools.

Required material

ROCKER_INDICATOR	9999683
MAGNETIC STAND	9999696



Note

Ensure that the probe tip touches the gear tooth.

210 Check the backlash.

Tech data

Gear, backlash	0.05 – 0.17 mm (0.002 – 0.0067 in)
----------------	---------------------------------------

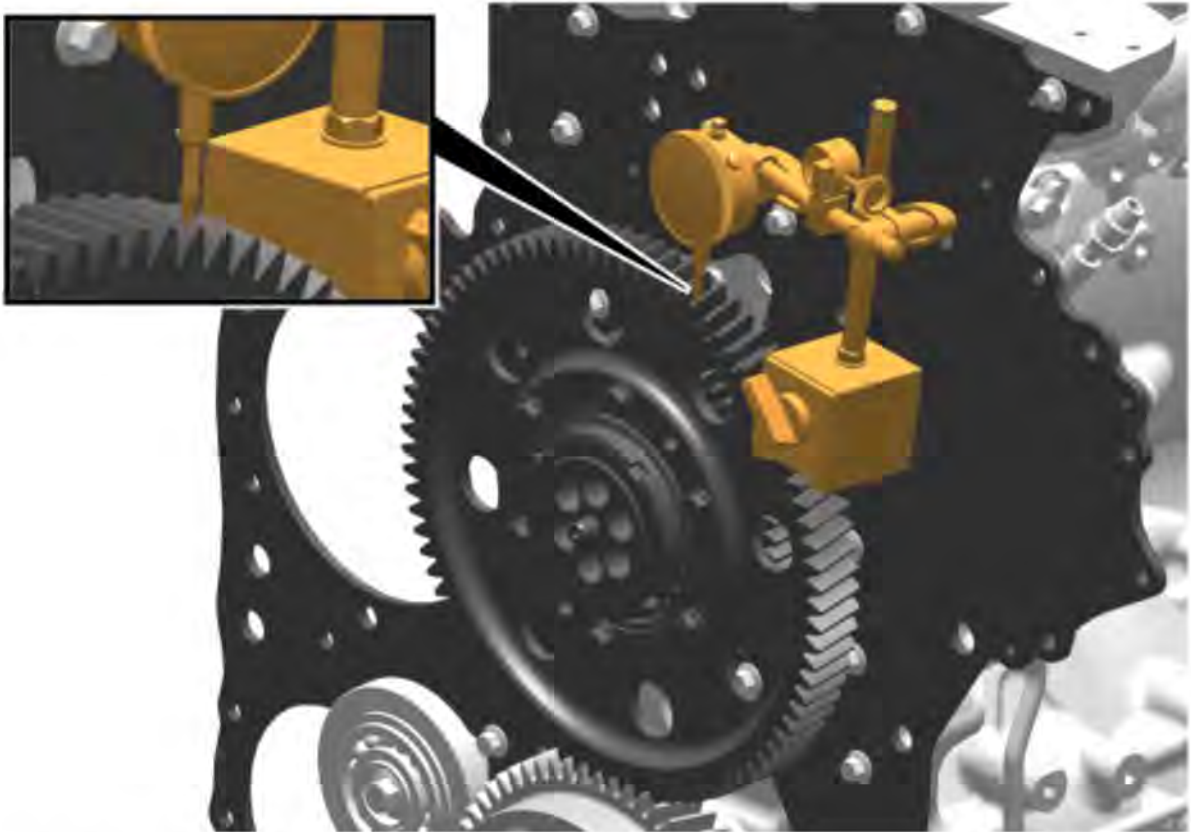

211 Perform this procedure when the condition below is met.

Conditions

- If the backlash is out of the specification
- ▶ Adjust the timing gear plate.

212 Perform this procedure when the condition below is met.

Conditions

- If all of the clearances are within the specifications
- ▶ Tighten the screws.

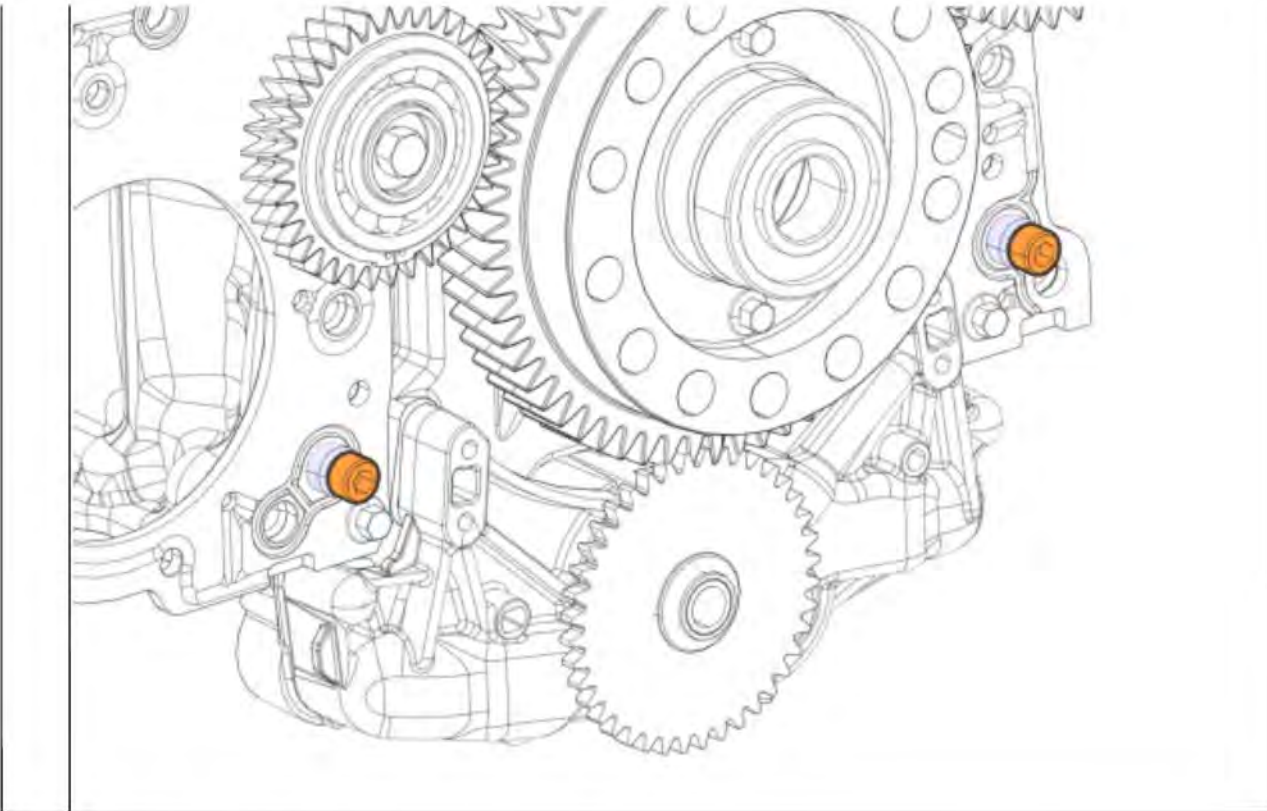

213	Remove the screws.
-----	--------------------

214	Remove the gears.
-----	-------------------



215	Remove the screws.
-----	--------------------

216	Remove the timing gear plate.
-----	-------------------------------

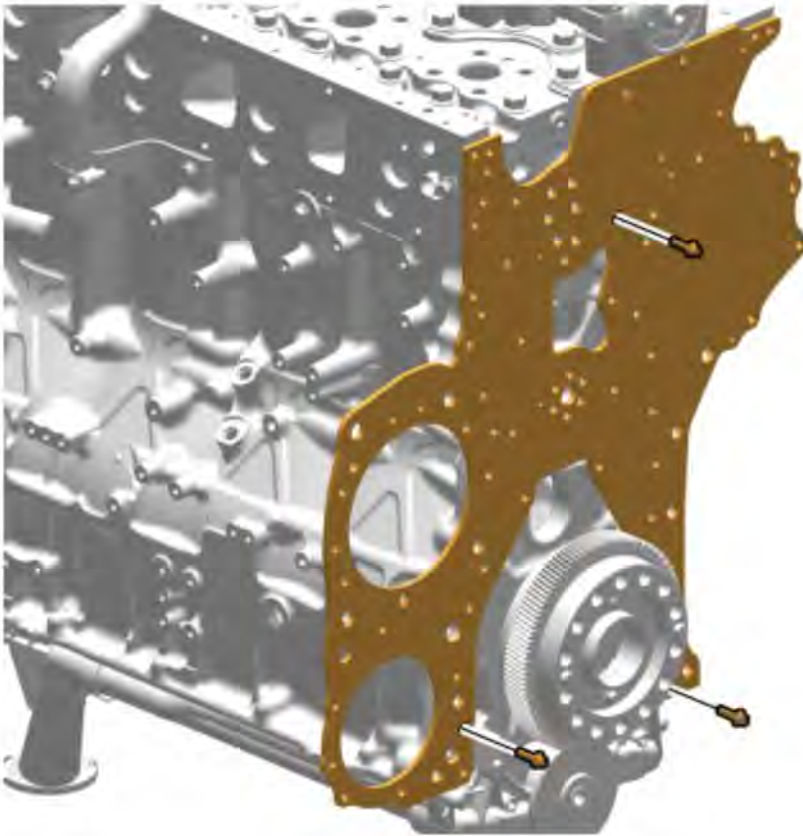

217 Clean the contact surfaces carefully.





Note

Do not use any tools that may damage the sealing surfaces.

218 Inspect the sealing strip surfaces on both side of the timing gear plate.

219 If the sealing strip is completely loose or damaged, the timing gear plate must be replaced.



220	Apply the sealant.
Tech data	
Sealant, bead thickness	2 mm (0.08 in)
	Note Use recommended sealant.
	Note Ensure that the surfaces are completely clean of oil and grease.
221	Install the noise shield.
	Note Install the noise shield within 20 minutes of applying the sealant.
222	Install the screws.

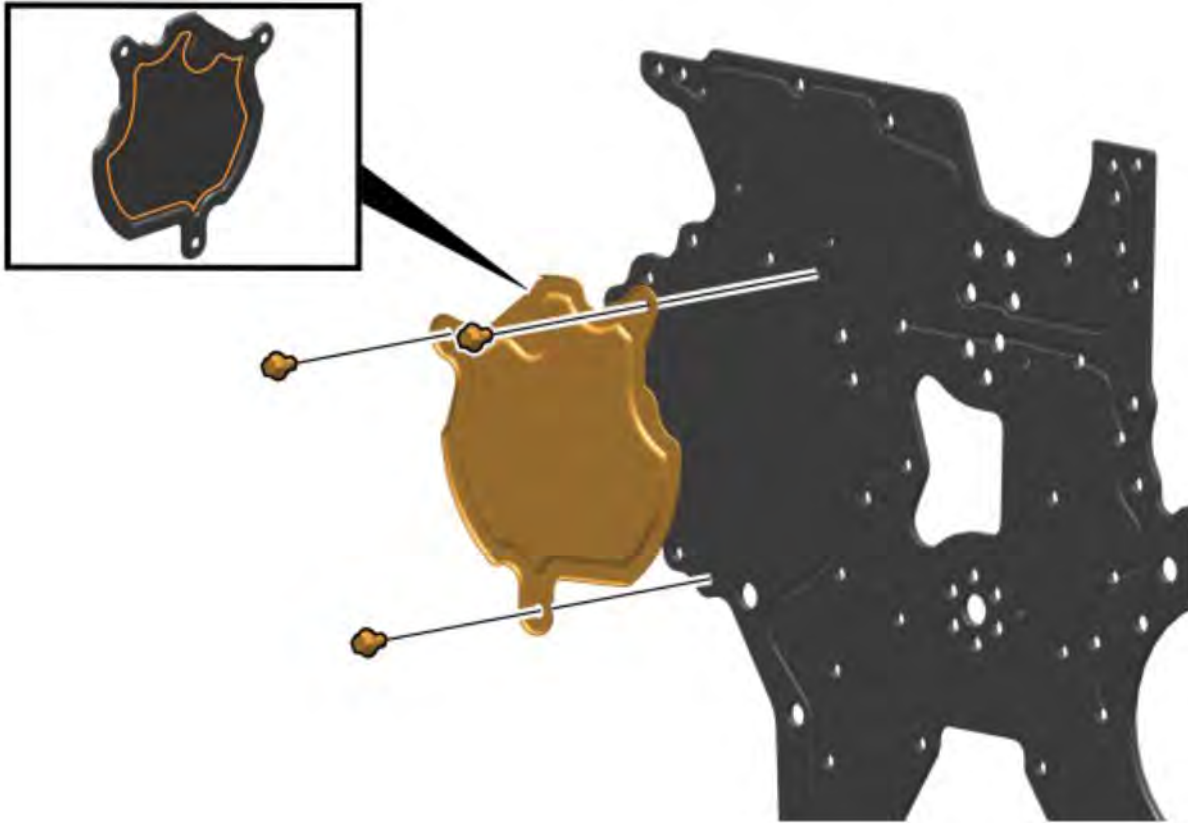

223 Install the timing gear plate.

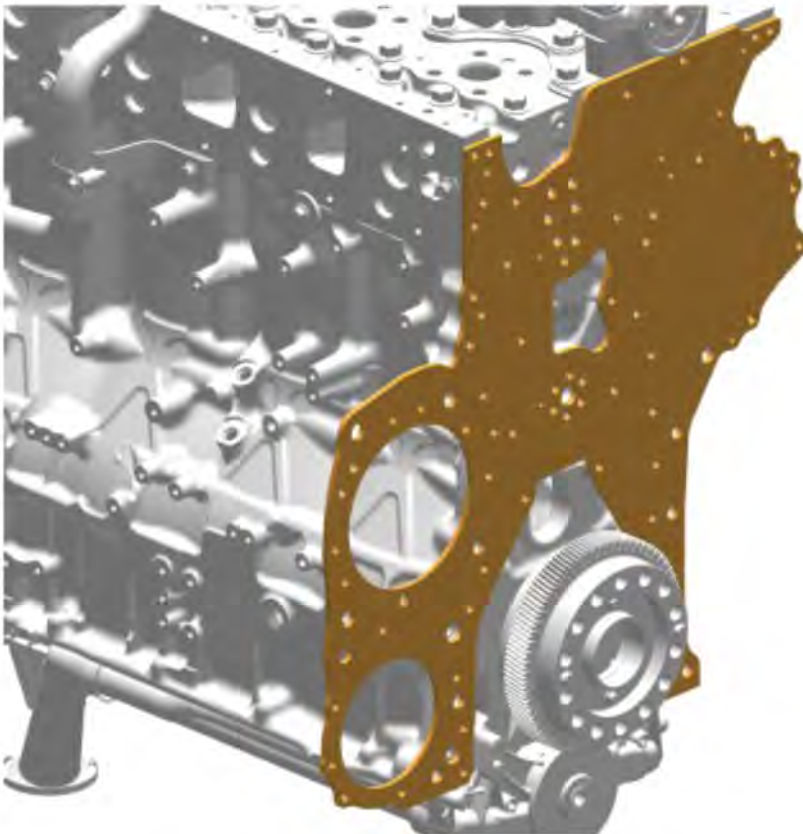

224 Install the screws.



Note

Use new parts.



Note

Only use screws that are pre-treated with locking compound.

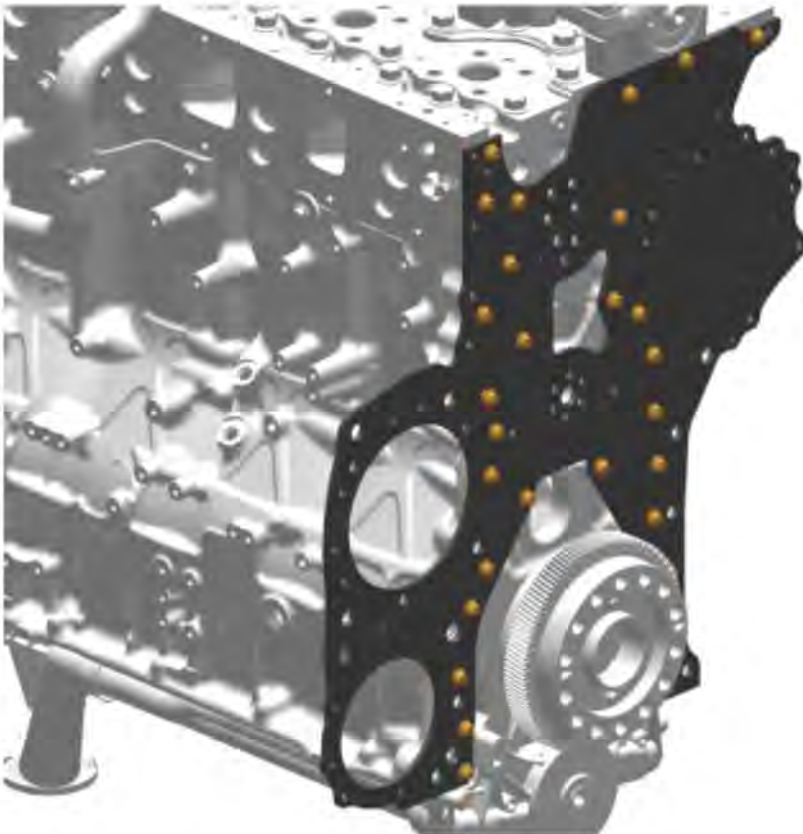

225 Lubricate the O-ring.



Note

Use a new part.



Note

Use recommended oil.

226 Install the O-ring.

227 Install the bracket.

228 Install the screw.



229	Torque tighten the screws.
-----	----------------------------

Tightening torque	
Timing gear plate, screw	Tightening sequence: 1 - 28
	28 ±4 Nm
	(21 ±3 lb _f ·ft)

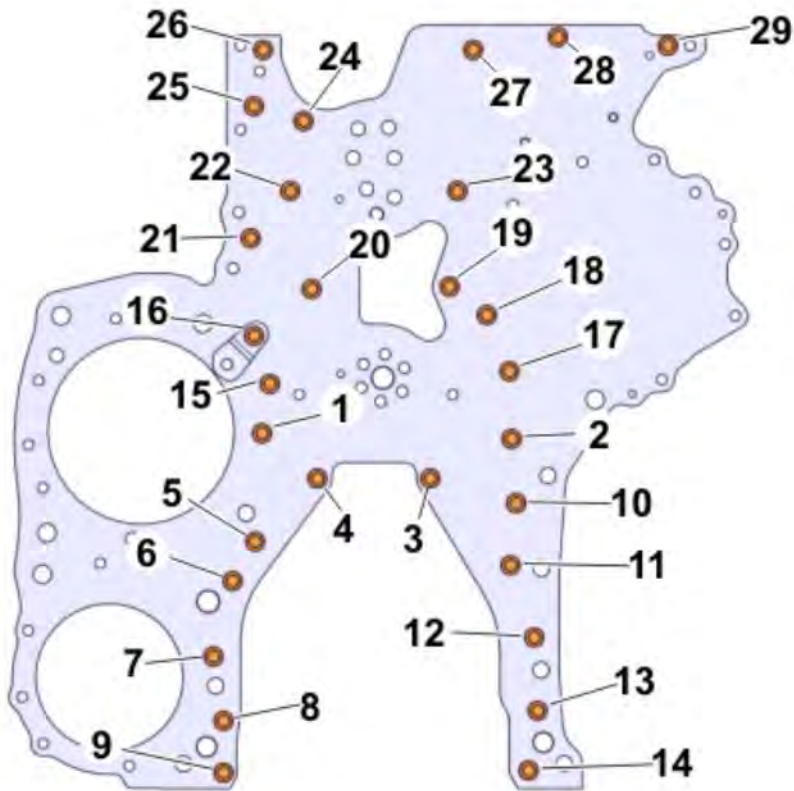

230	Remove the tools.
------------	-------------------

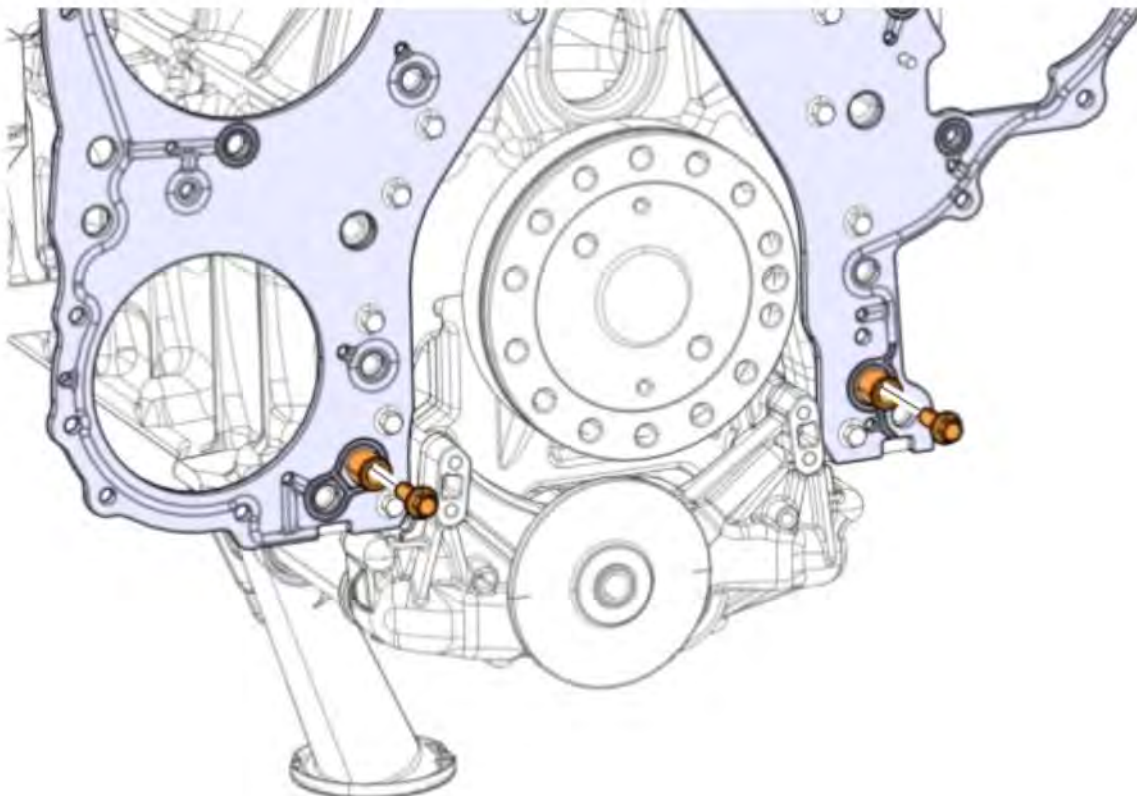

231	Clean the timing gear plate.
------------	------------------------------

232	Install the thrust washer.
------------	----------------------------

233	Install the gear.
-----	-------------------

234	Install the screws.
-----	---------------------

**Note**

Hand tighten the screws.

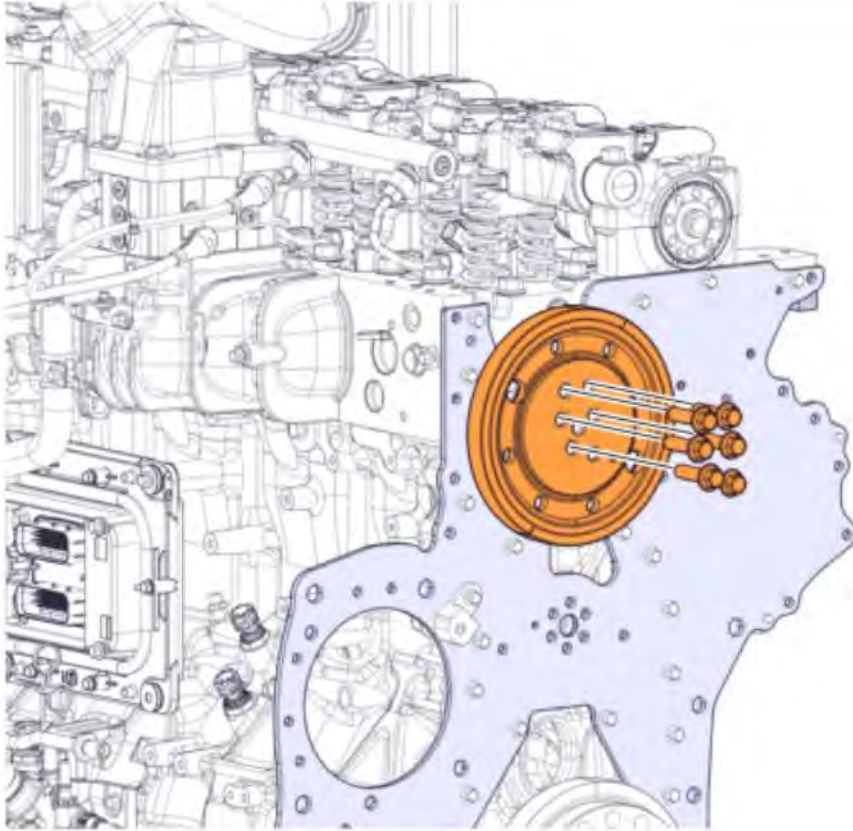

235	Install the gear.
-----	-------------------

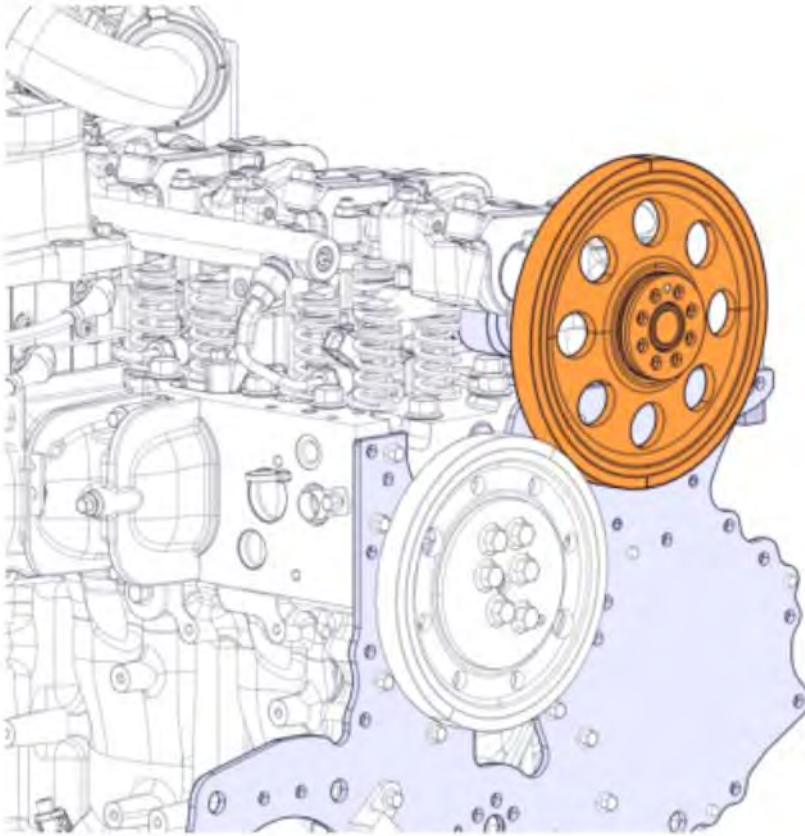

236	Install the tool.
	Required material
	KIT J-44514B

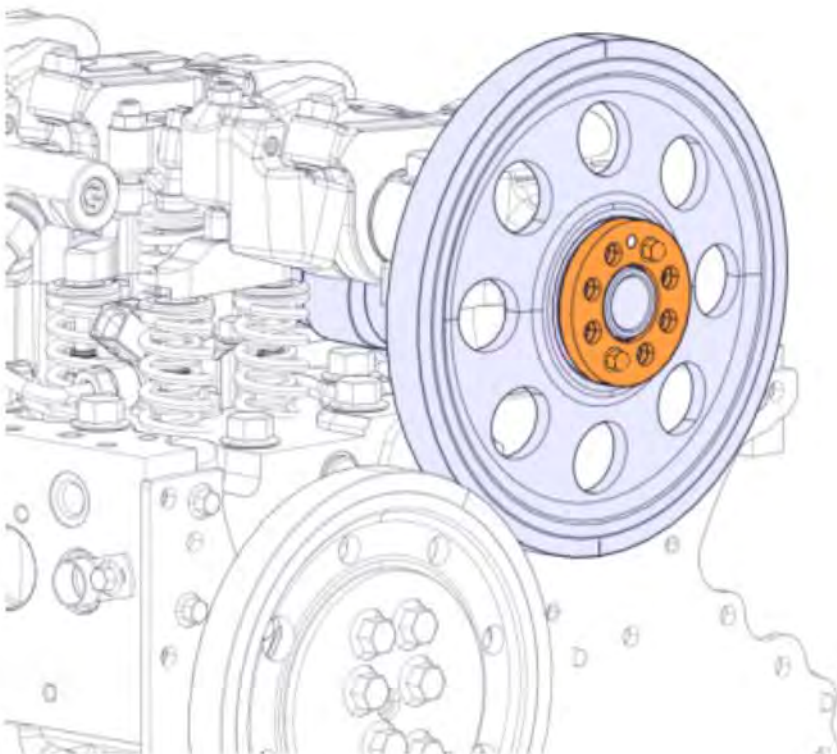

237	Install the feeler gauge.	
	Tech data	
	Feeler gauge, thickness	0.1 mm (0.004 in)

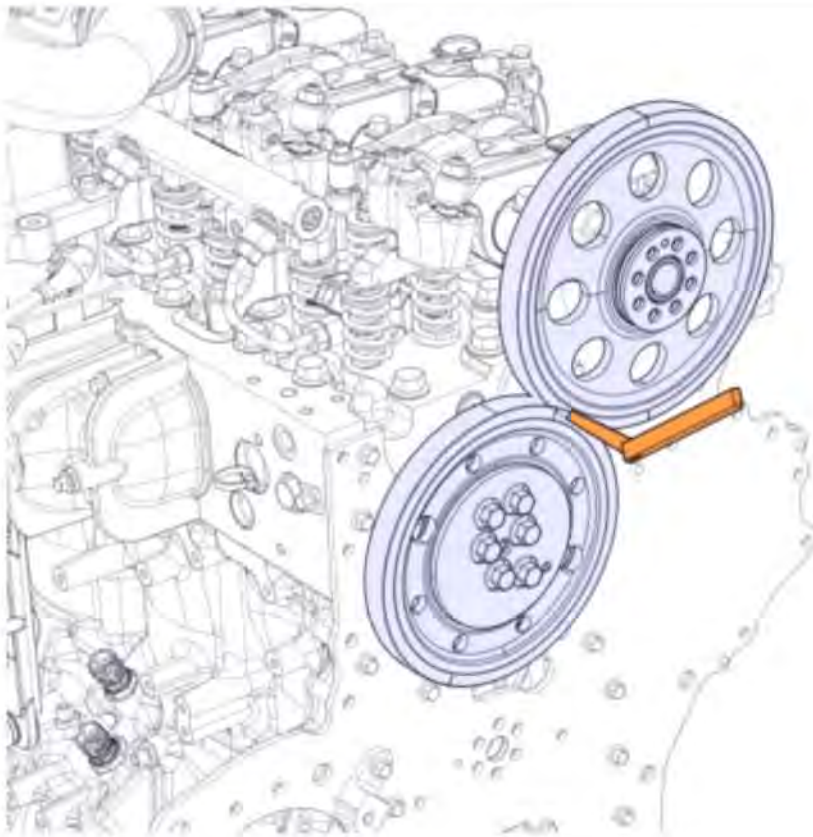

238	Adjust the clearance.	
	i	Note Adjust the idler gear to adjust the clearance.
i	Note Ensure that a feeler gauge inserted between the teeth is difficult to move.	

239	Install the tools.	
	Required material	
	MAGNETIC STAND	9999696
	ROCKER_INDICATOR	9999683
i	Note Ensure that the probe tip touches the gear tooth.	

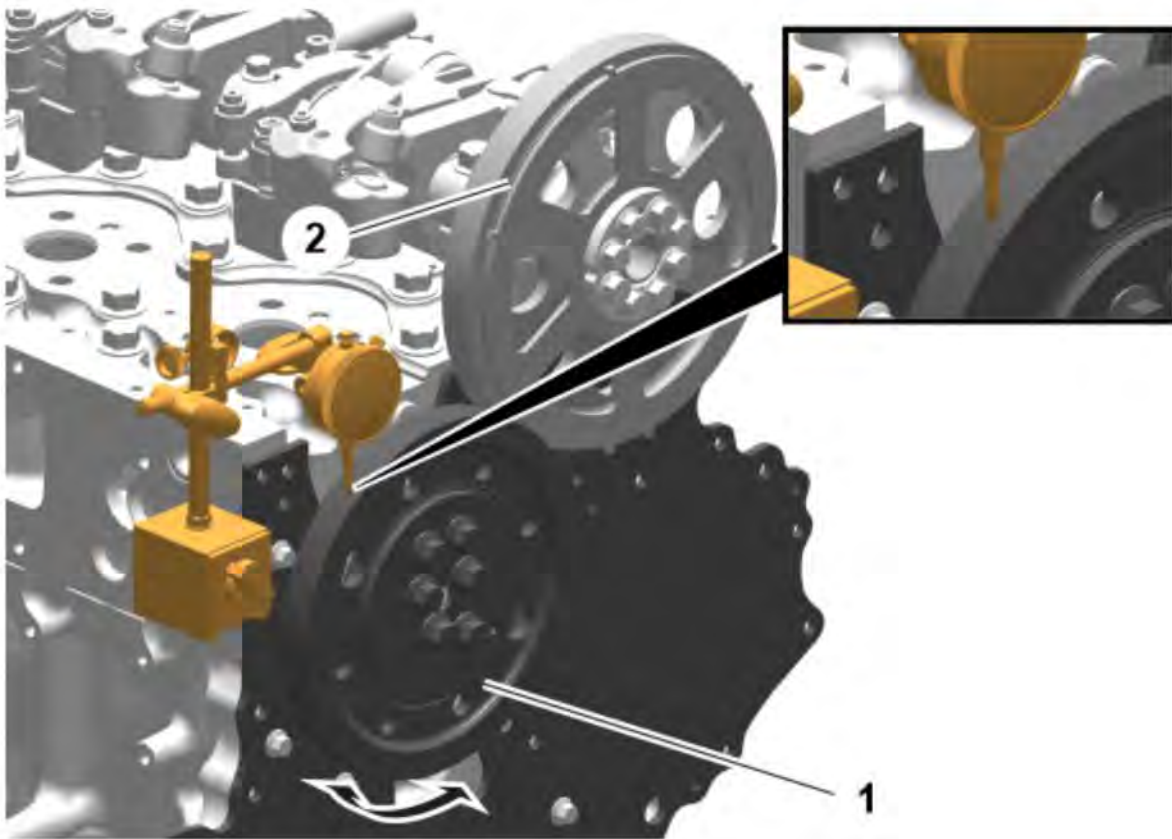

240	Install the tool.
Required material	
KIT	J-44514B

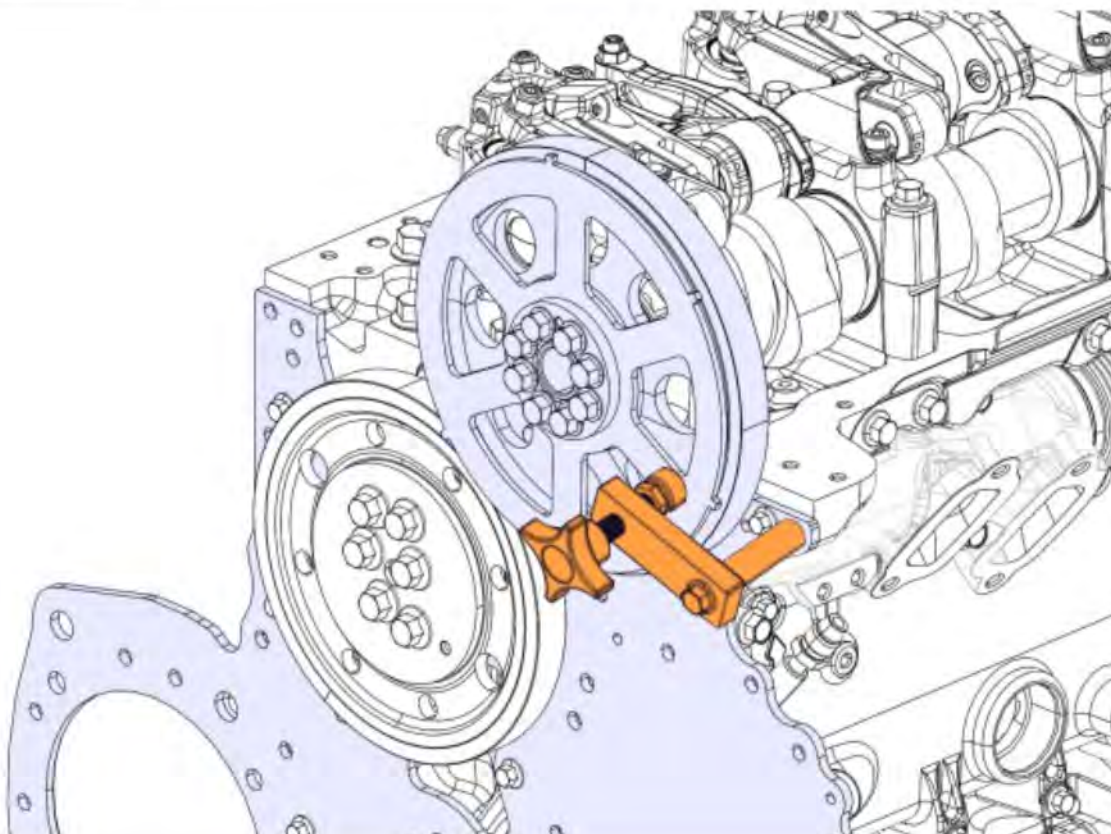

241	Check the backlash between gears 1 and 2.	
Tech data		
Backlash clearance		0.1 ±0.05 mm (0.004 ±0.002 in)

242	Perform this procedure when the condition below is met.			
Conditions				
<ul style="list-style-type: none"> If the backlash is not within specified value. 				
<ul style="list-style-type: none"> Readjust the gears. 				
<table border="1" style="width: 100%;"> <tr> <td style="width: 10%; text-align: center;">i</td> <td>Note The tool must be removed to readjust the gears.</td> </tr> </table>			i	Note The tool must be removed to readjust the gears.
i	Note The tool must be removed to readjust the gears.			

243	Remove the tool.
------------	------------------

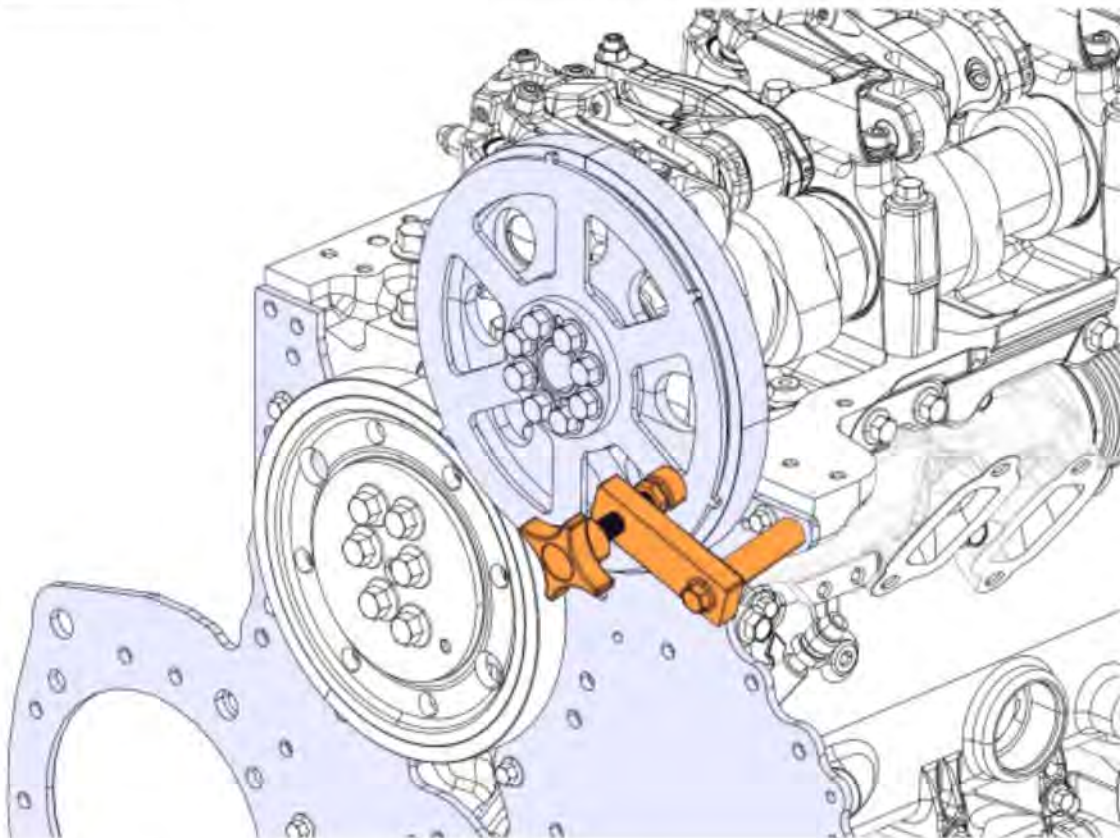

244	Remove the tools.
------------	-------------------

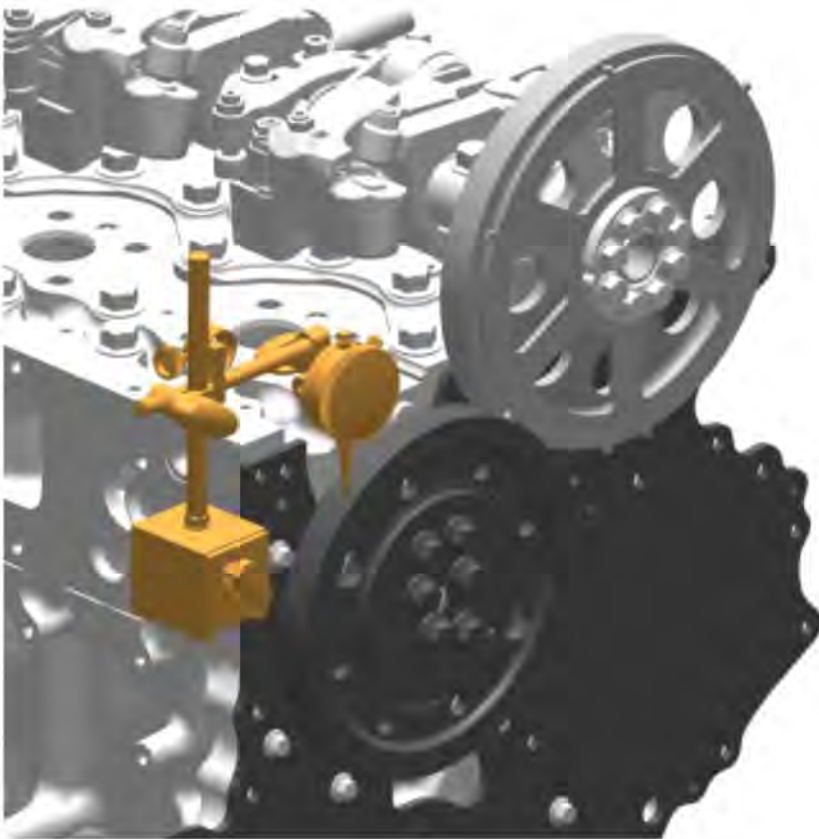

245	Torque tighten the screws.
-----	----------------------------

Tightening torque		
Idler gear, screw	1.	Tightening sequence: 1–6
		35 ±4 Nm (26 ±3 lb _f -ft)
	2.	Tightening sequence: 1–6
		120 ±5°

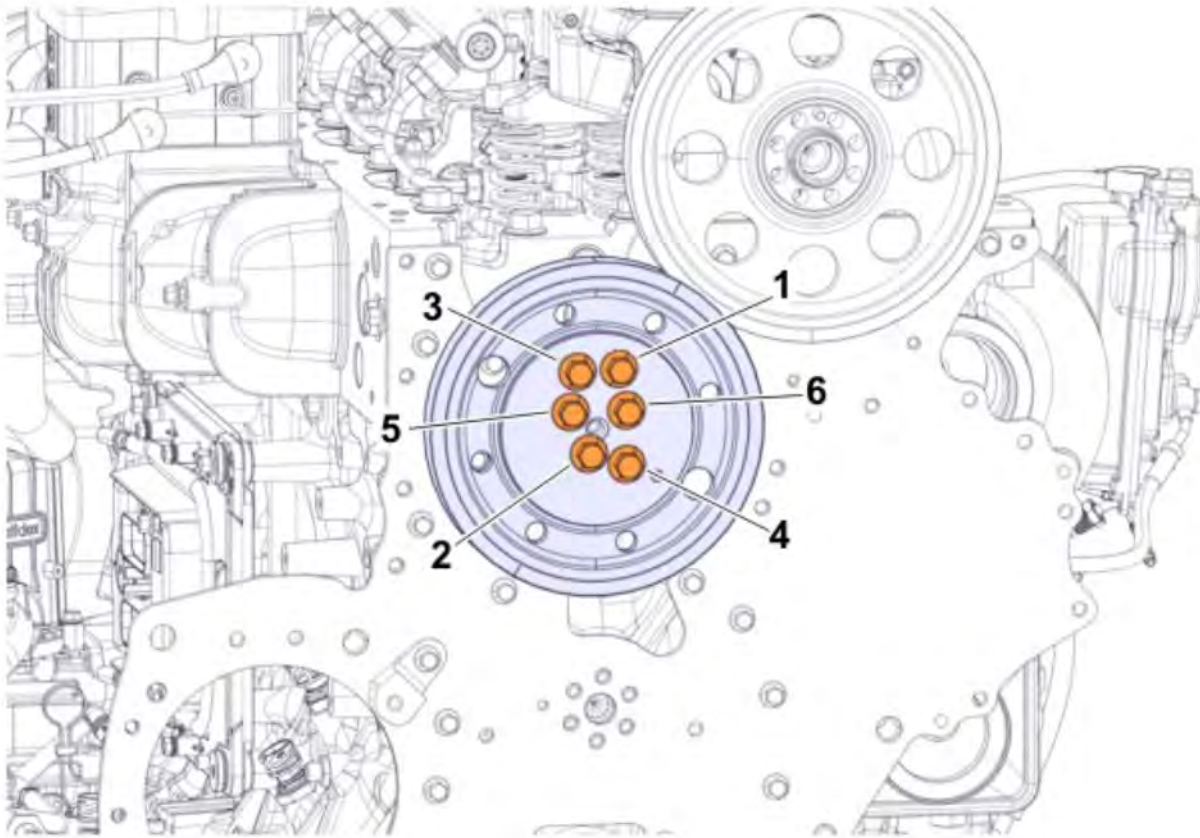

246 Verify that the camshaft position markings are at (TDC).

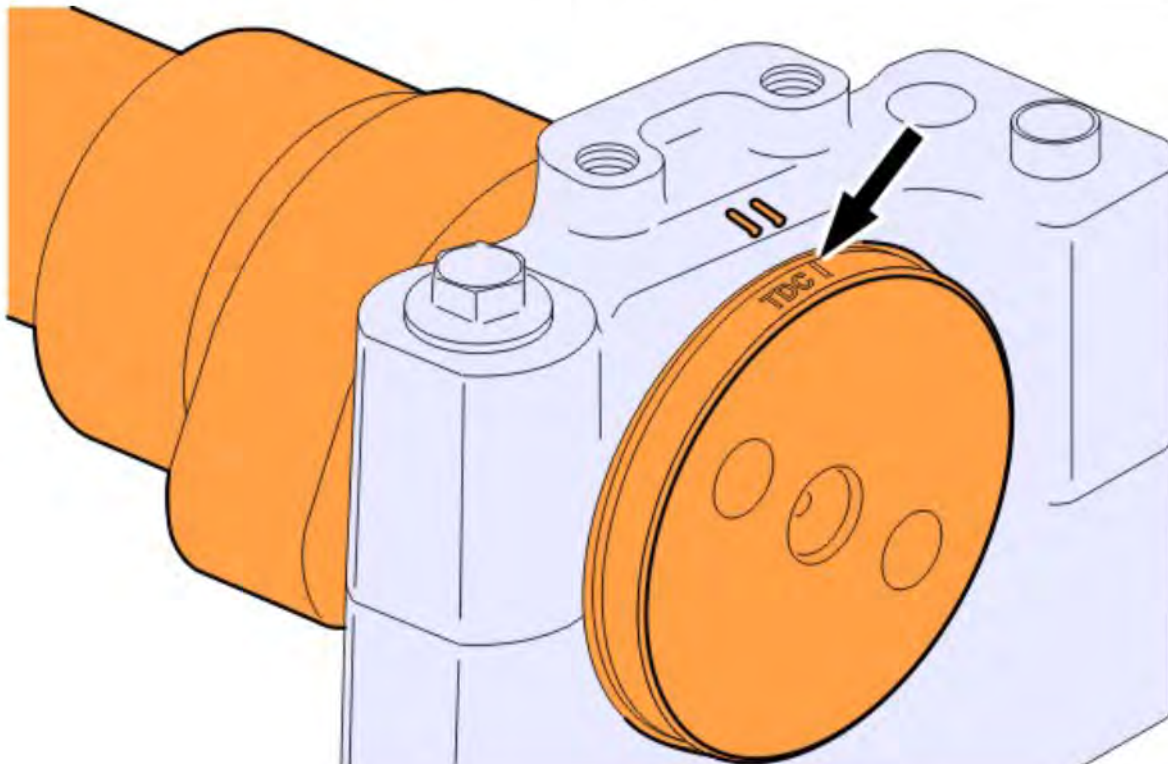

247	Install the cam gear aligner.
Required material	
KIT	J-44514B

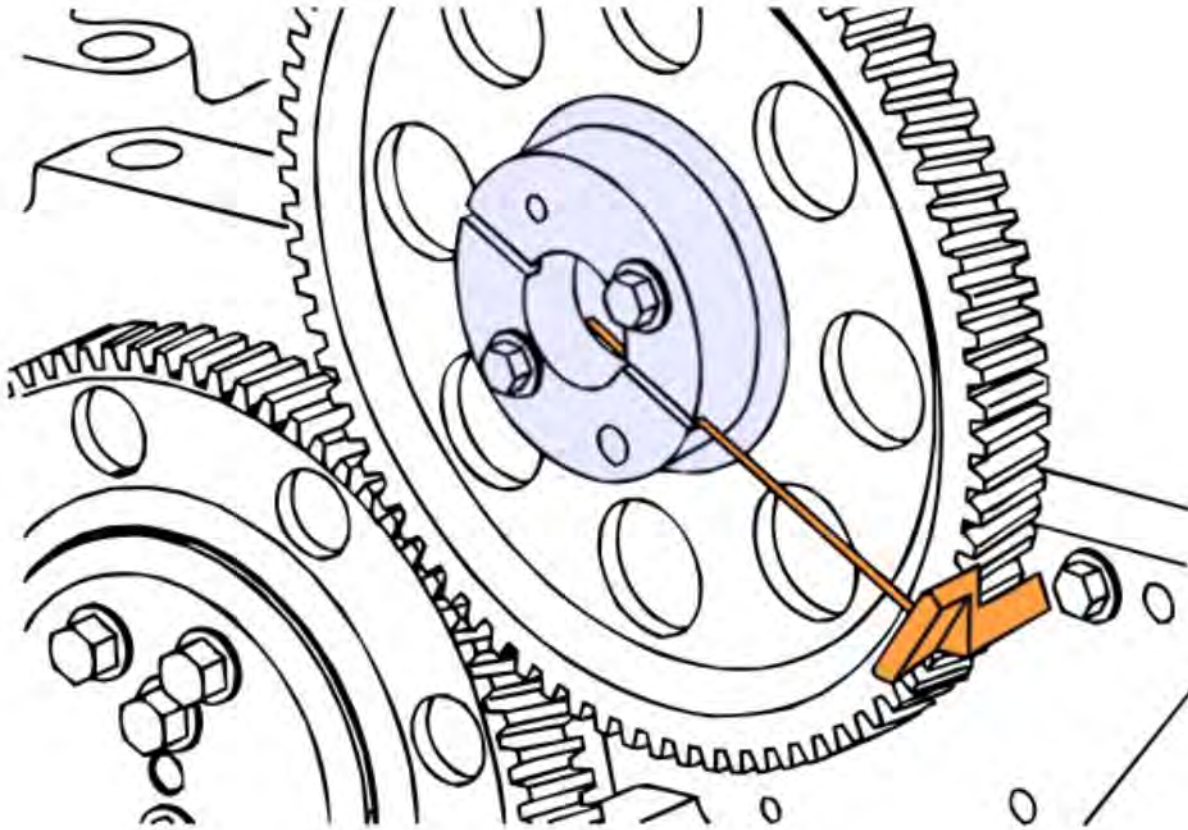

248 Install the gears.



Note

Ensure the markings correctly align.



Note

Remove the cam gear aligner.

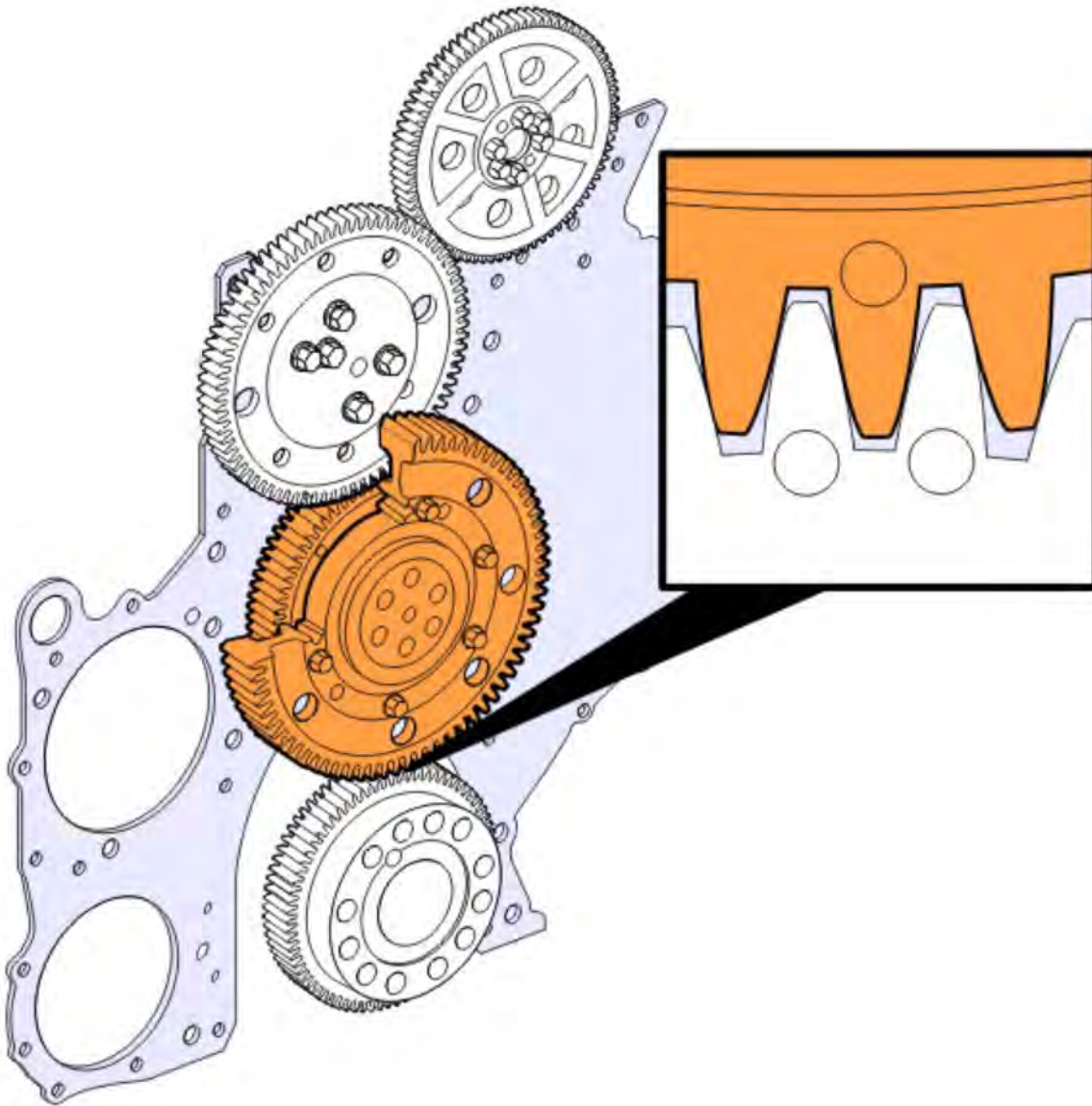

249 Install the screws.

i	Note Use new parts.
----------	-------------------------------

250 Torque tighten the screws.

Tightening torque		
Double idler gear, screw	1.	Tightening sequence: 1-6
		25 ±3 Nm (18 ±2 lb _f -ft)
	2.	Tightening sequence: 1-6
		110 ±5°

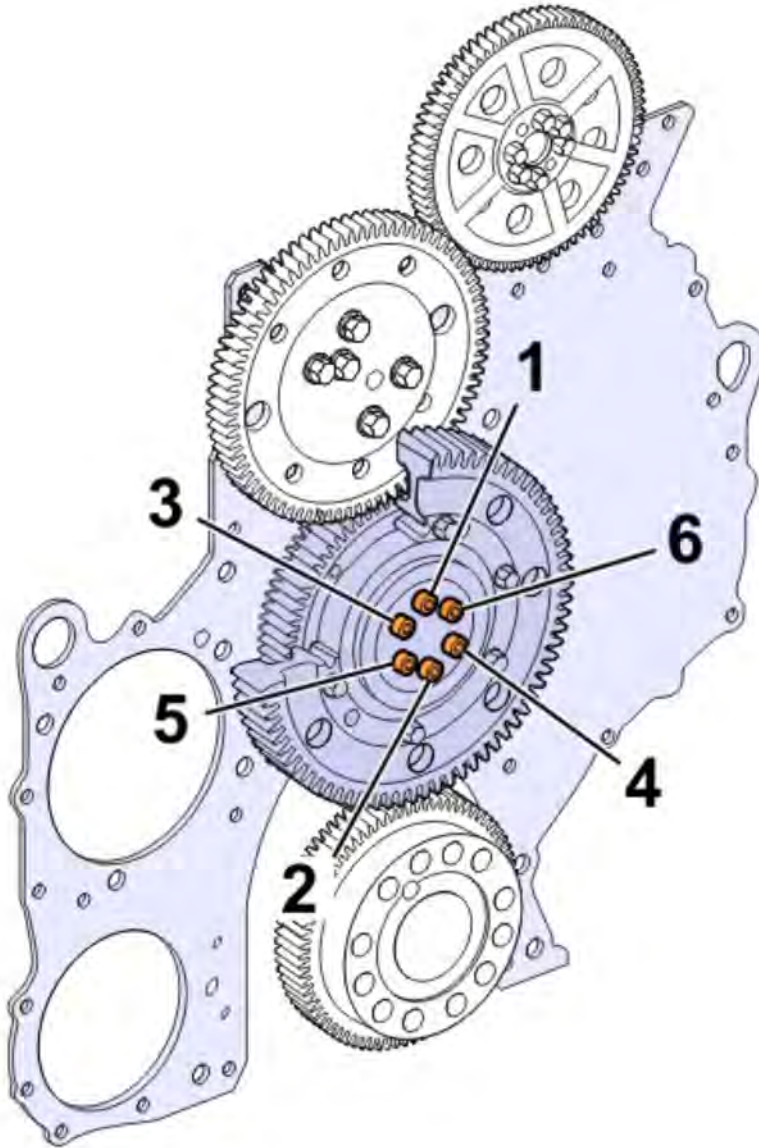

251	Remove the tool.
-----	------------------

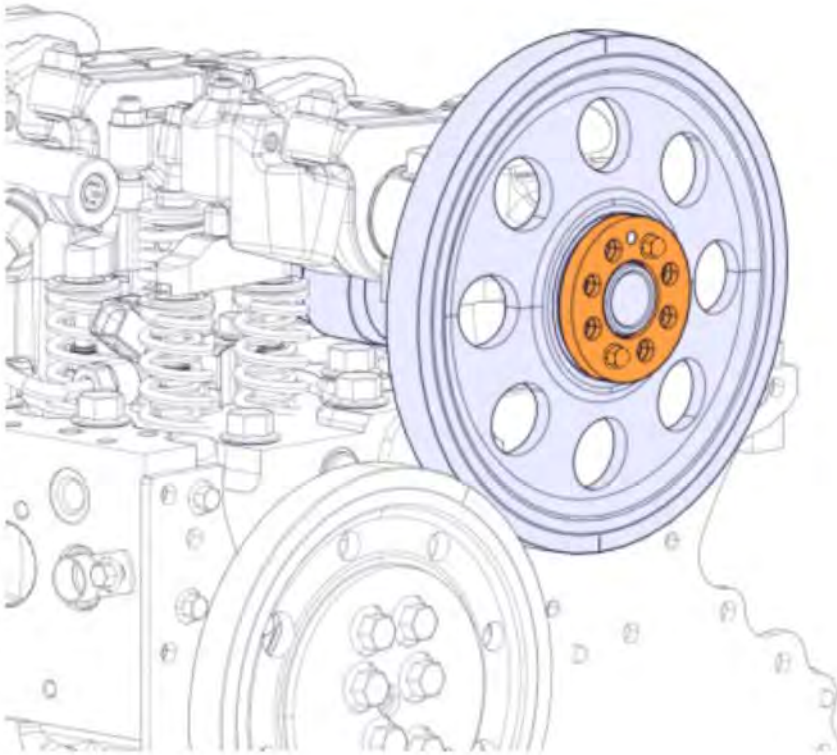

252 Install the tone wheel and screws.



Note

Use new screws.

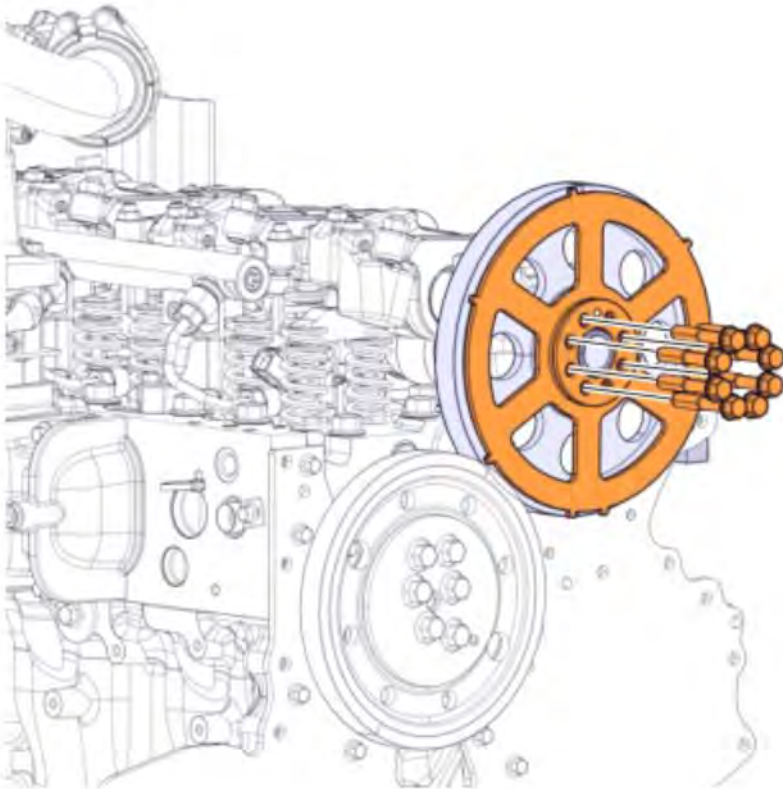

253 Torque tighten the screws.

Copyright to this documentation belongs to the Volvo Group. No reproduction, copying, change, amendment or other similar disposal is entitled without prior written consent by the Volvo Group

The information contained herein is current at the time of its original distribution, but is subject to change. The reader is advised that printed copies are uncontrolled.

Tightening torque		
Camshaft gear, screw	1.	Tightening sequence: 1-8
		45 ±5 Nm (33 ±4 lb _f .ft)
	2.	Tightening sequence: 1-8
		90 ±5°

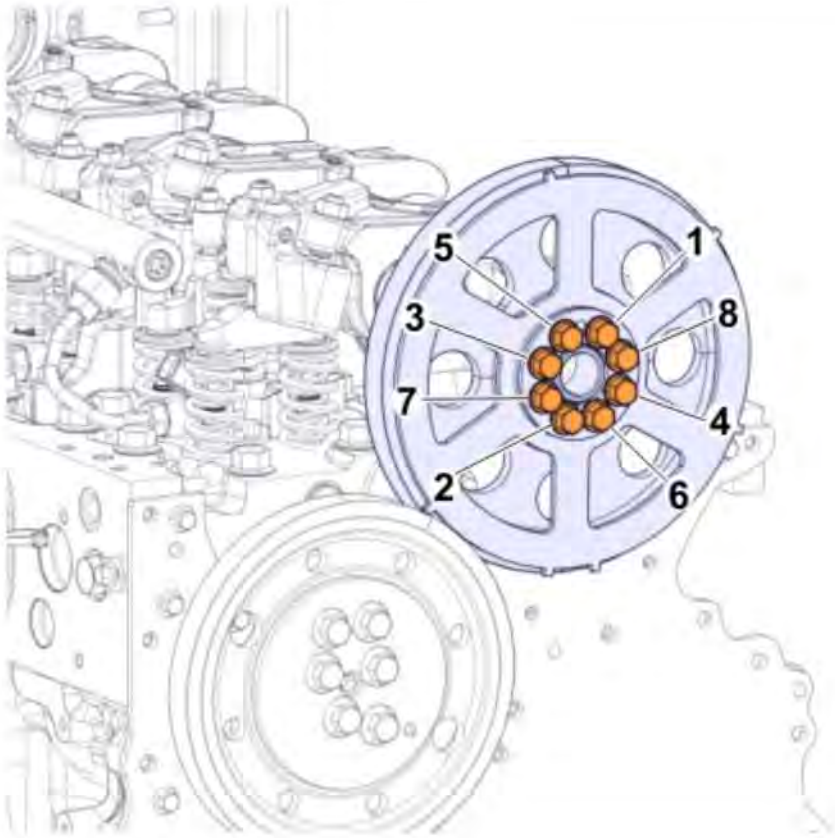

- | | |
|-----|---------------------------|
| 254 | Install the gear. |
| 255 | Install the screw. |
| 256 | Torque tighten the screw. |

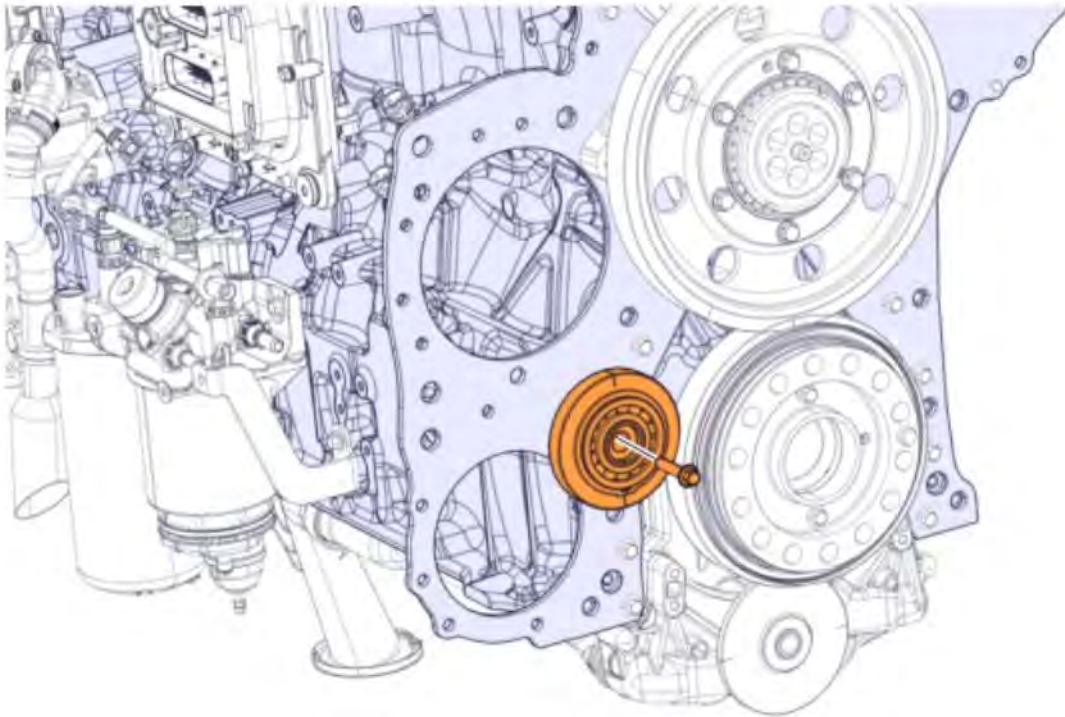

Tightening torque	
Idler gear, servo pump, screw	140 ±10 Nm (103 ±7 lb _f ·ft)

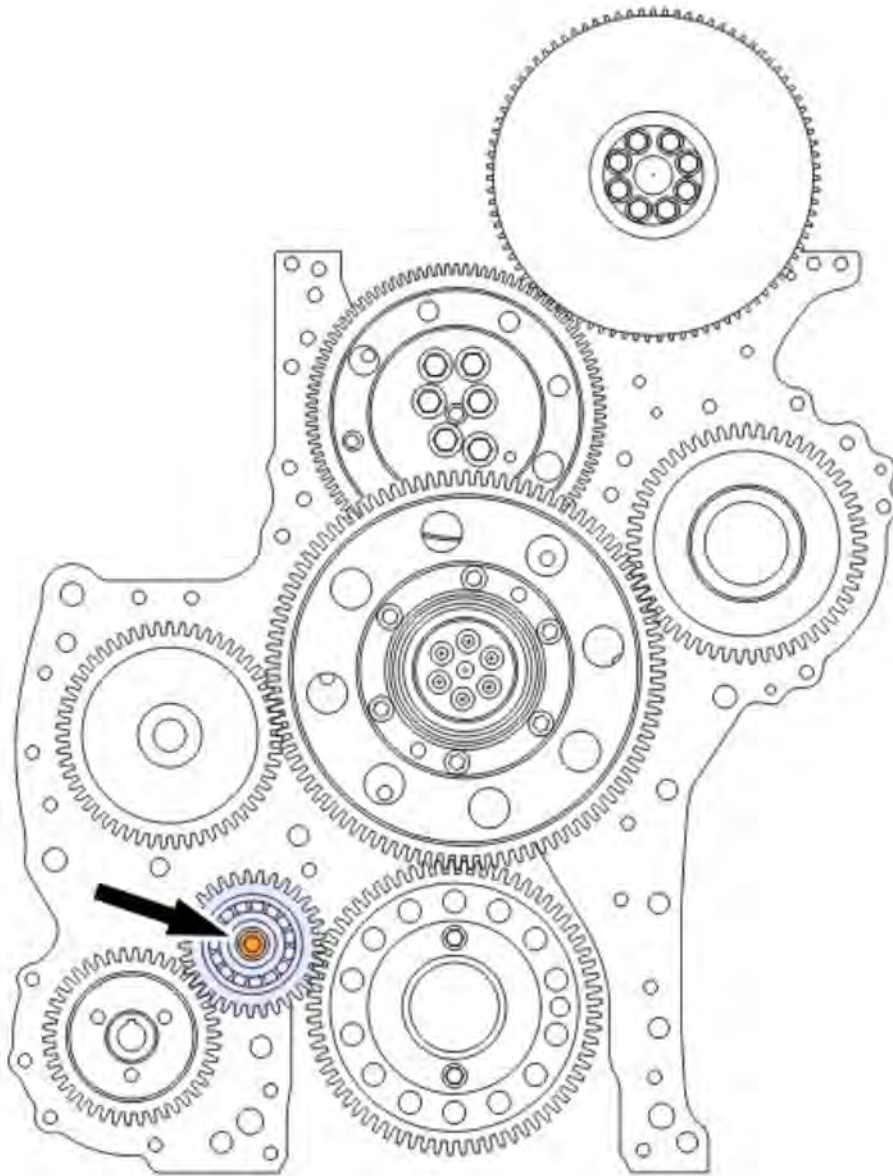

257 Clean the contact surfaces carefully.



Note

Do not use any tools that may damage the sealing surfaces.

258 Inspect the sealing strip surfaces on both side of the timing gear plate.

259 If the sealing strip is completely loose or damaged, the timing gear plate must be replaced.

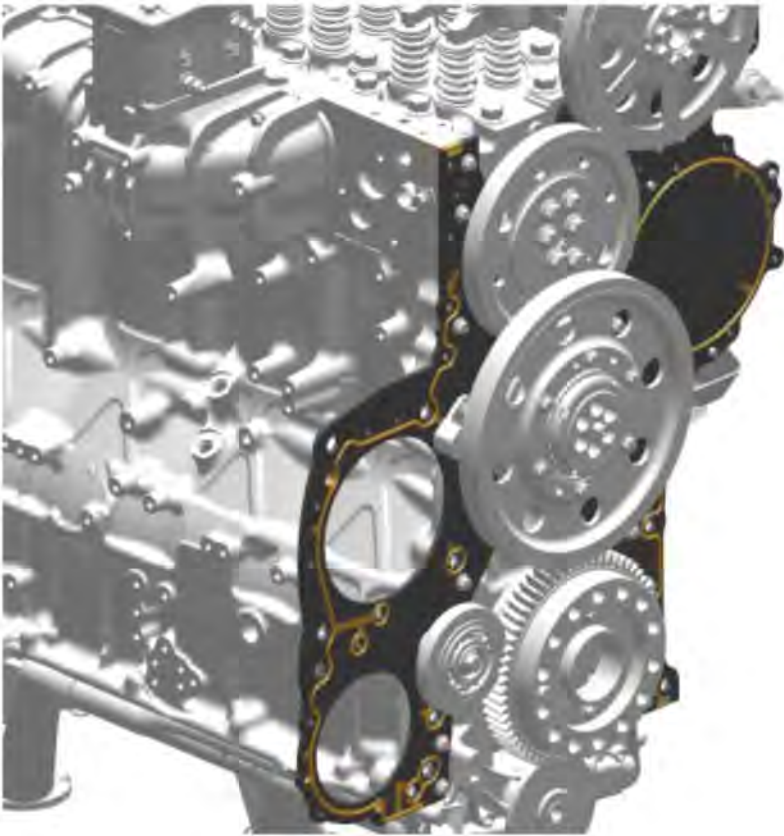
**CAUTION****Risk of serious injury.**

Heavy component.

- ▶ Exercise caution when moving the component. Use appropriate tools.

260 Install the flywheel housing.

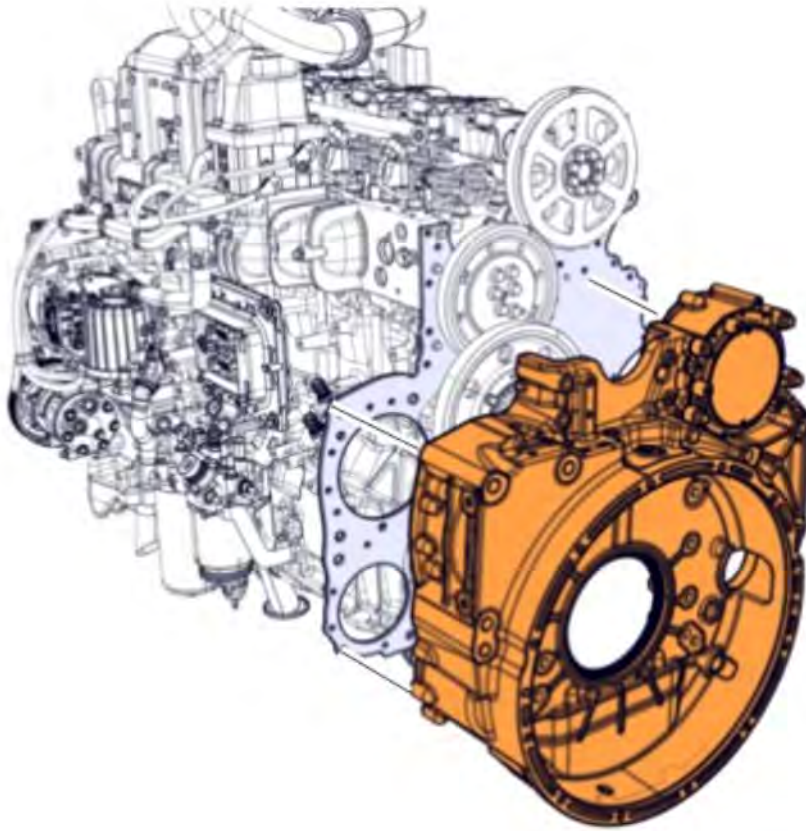

261 Install the screws.



Note

Remove the alignment dowels.

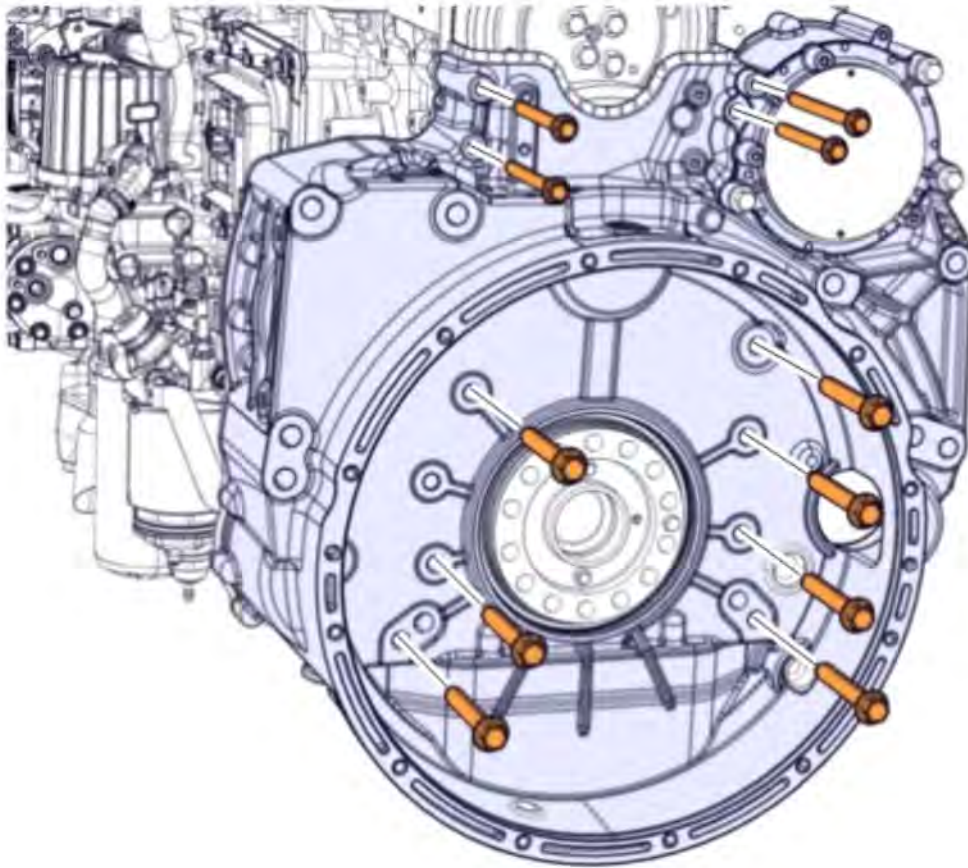

262 Torque tighten the screws.

Tightening torque		
Flywheel housing, screw	1.	M14
		Tightening sequence: 1-7
		36 ±10 Nm (27 ±7 lb _f .ft)
	2.	M14
		Tightening sequence: 1-7
		160 ±20 Nm (118 ±15 lb _f .ft)
	3.	M10
		Tightening sequence: 8-11
		60 ±10 Nm (44 ±7 lb _f .ft)

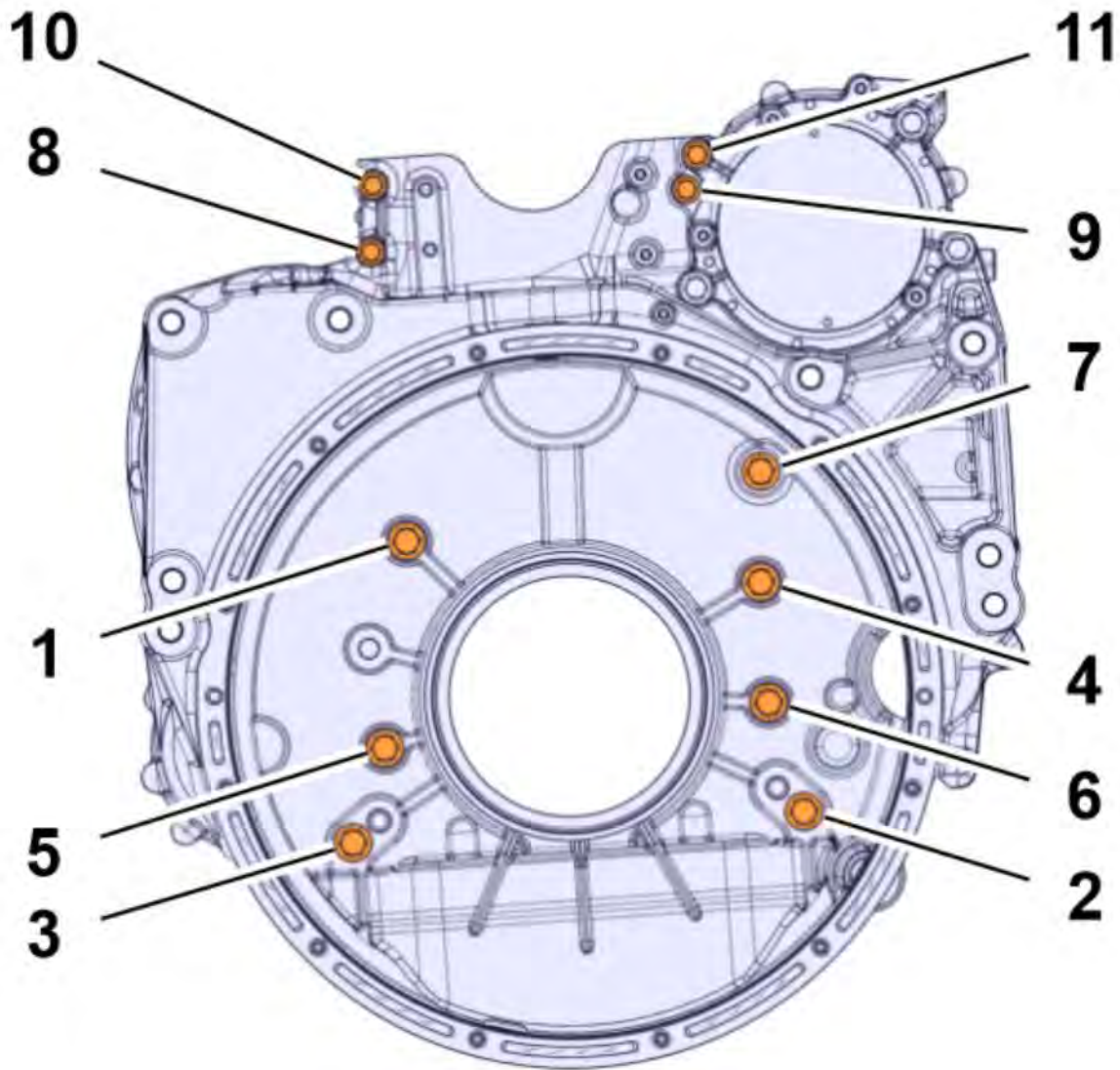

263	Install the screws.		
	<table border="1" style="width: 100%;"> <tr> <td style="width: 20px; text-align: center;">i</td> <td>Note Some housings may not include all the screws shown.</td> </tr> </table>	i	Note Some housings may not include all the screws shown.
i	Note Some housings may not include all the screws shown.		

264	Torque tighten the screws.	
	Tightening torque	
	Screw	M8
		24 ±4 Nm
		(18 ±3 lb _f -ft)

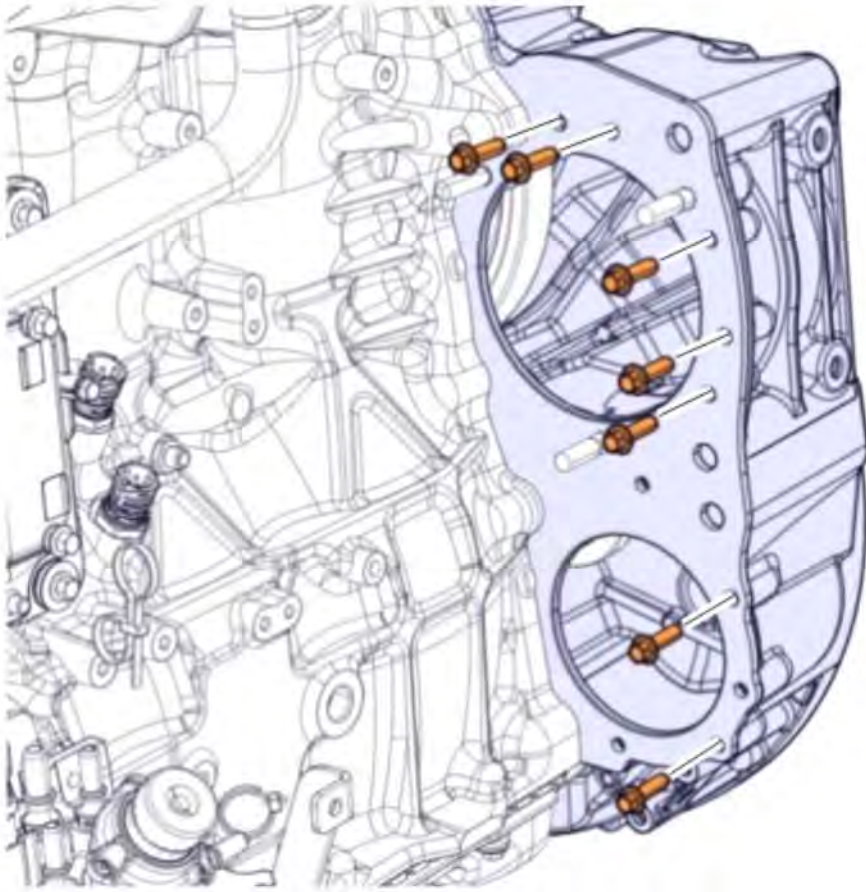

265 Install the bracket and the screws.

266 Torque tighten the screws.

Tightening torque

Screw	M8
	24 ±4 Nm
	(18 ±3 lb _f -ft)

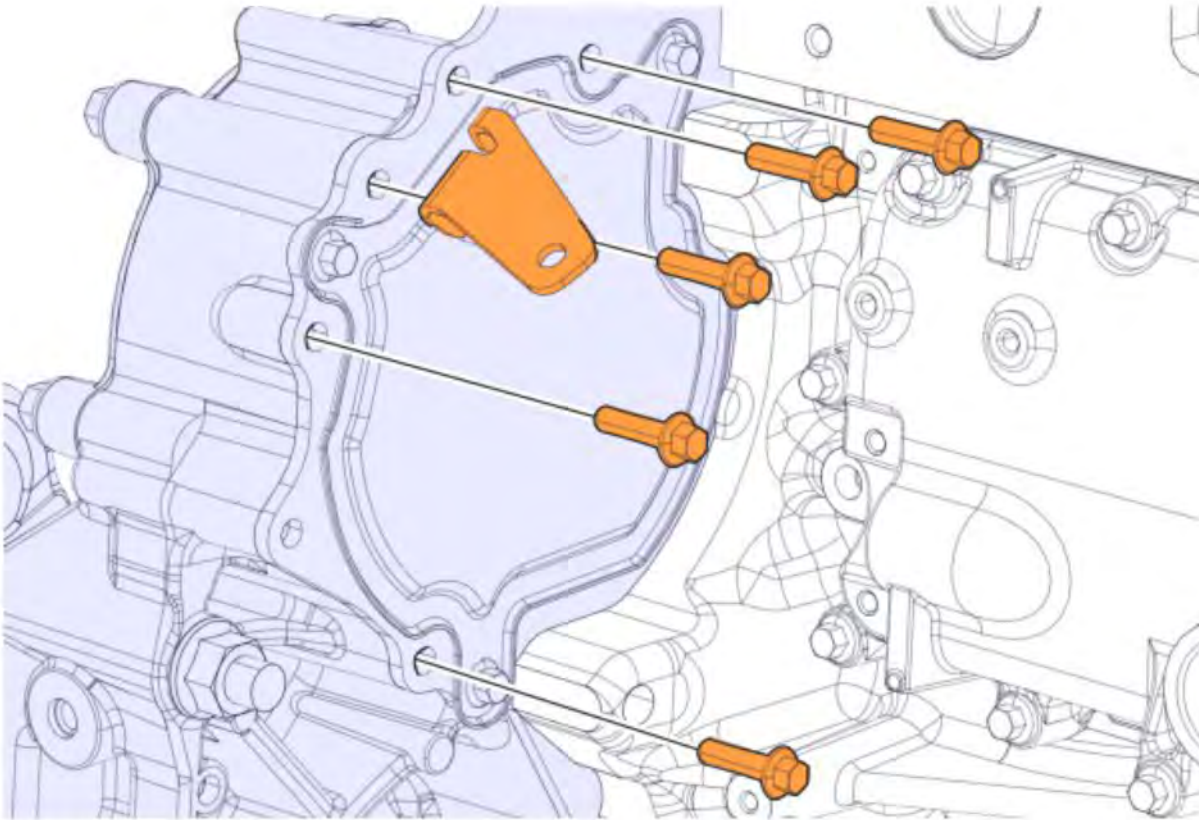

267	Install the bracket.
------------	----------------------

268	Install the screw.
------------	--------------------

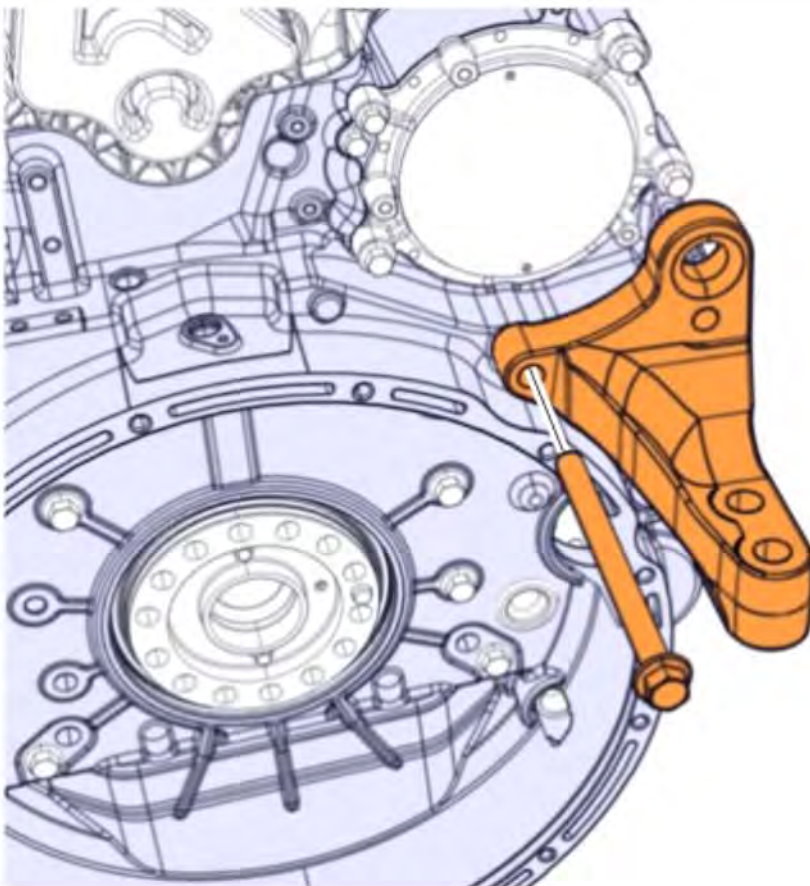

269	Install the screw.
------------	--------------------

270 Install the screw and nut.

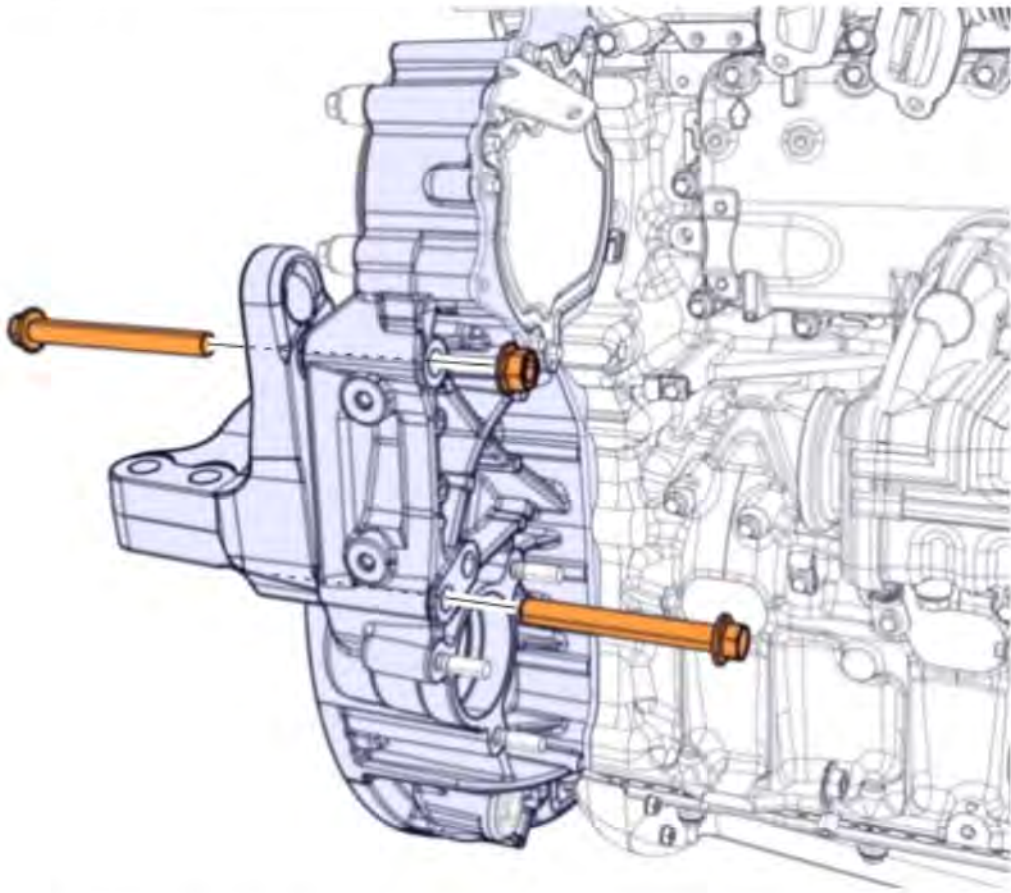

271	Torque tighten the screws and nut.	
	Tightening torque	
	Engine bracket, flywheel housing, rear, screw	275 ±45 Nm (203 ±33 lb _f -ft)

272 Install the bracket.

273 Install the screw.

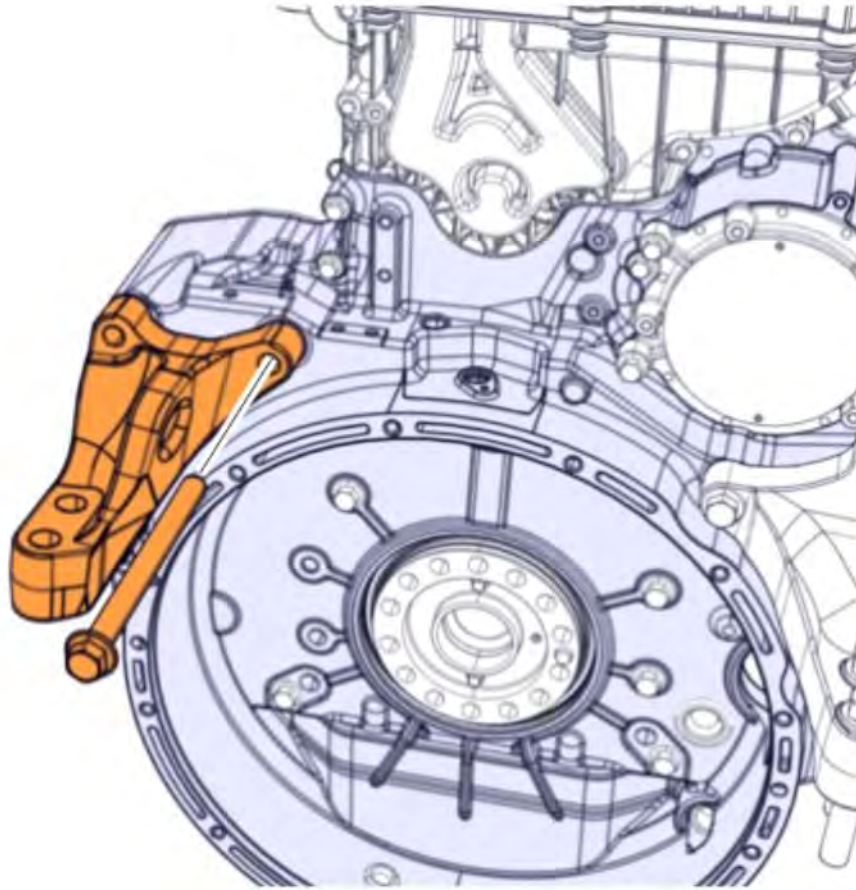

274	Install the screw.
-----	--------------------

275	Install the screw and nut.
-----	----------------------------

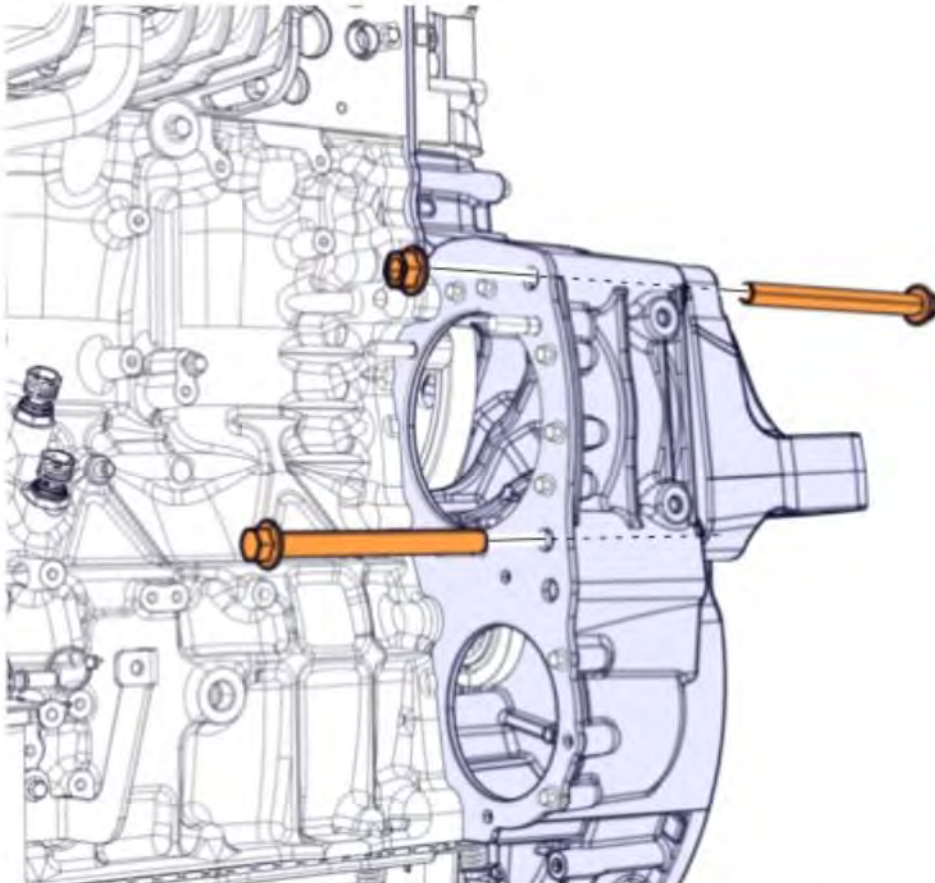

276 Torque tighten the screws and nut.

Tightening torque

Engine bracket, flywheel housing, rear, screw

275 ±45 Nm

(203 ±33 lb_f·ft)

277 Install the rubber cushion.

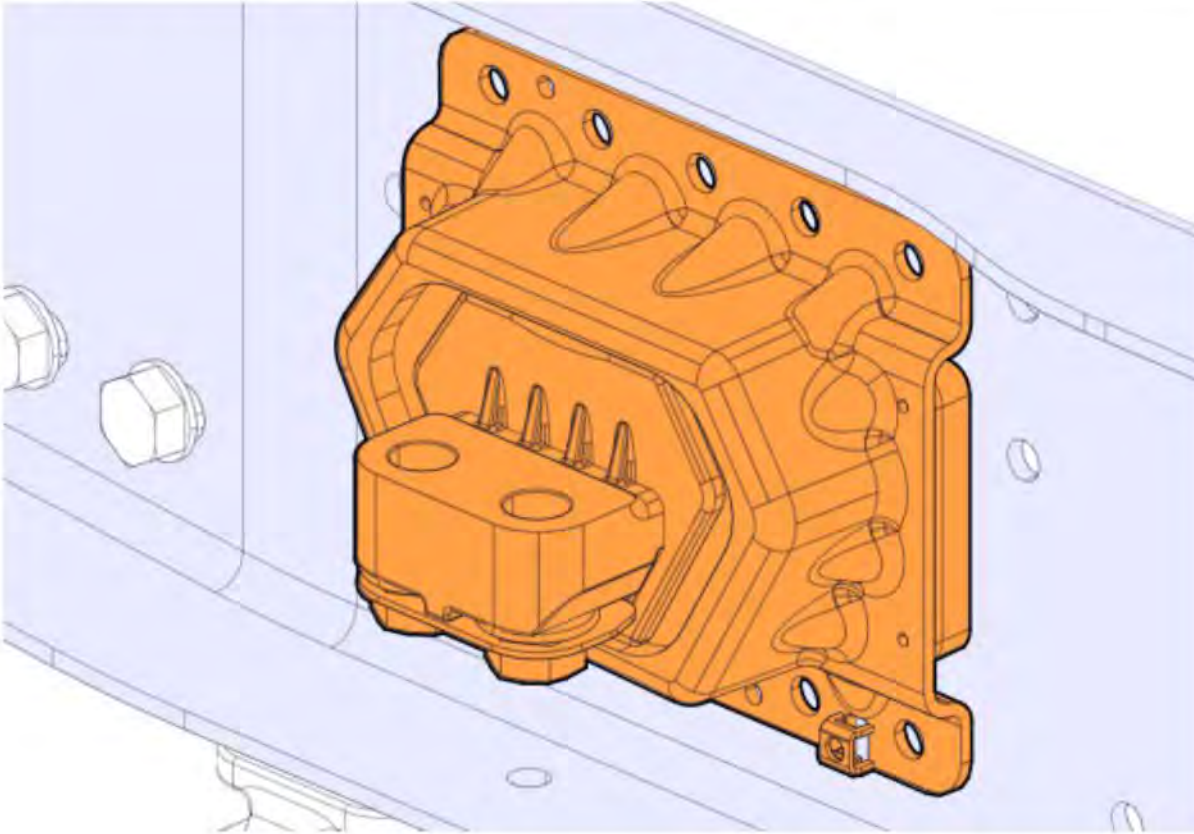

278 Install the screws.

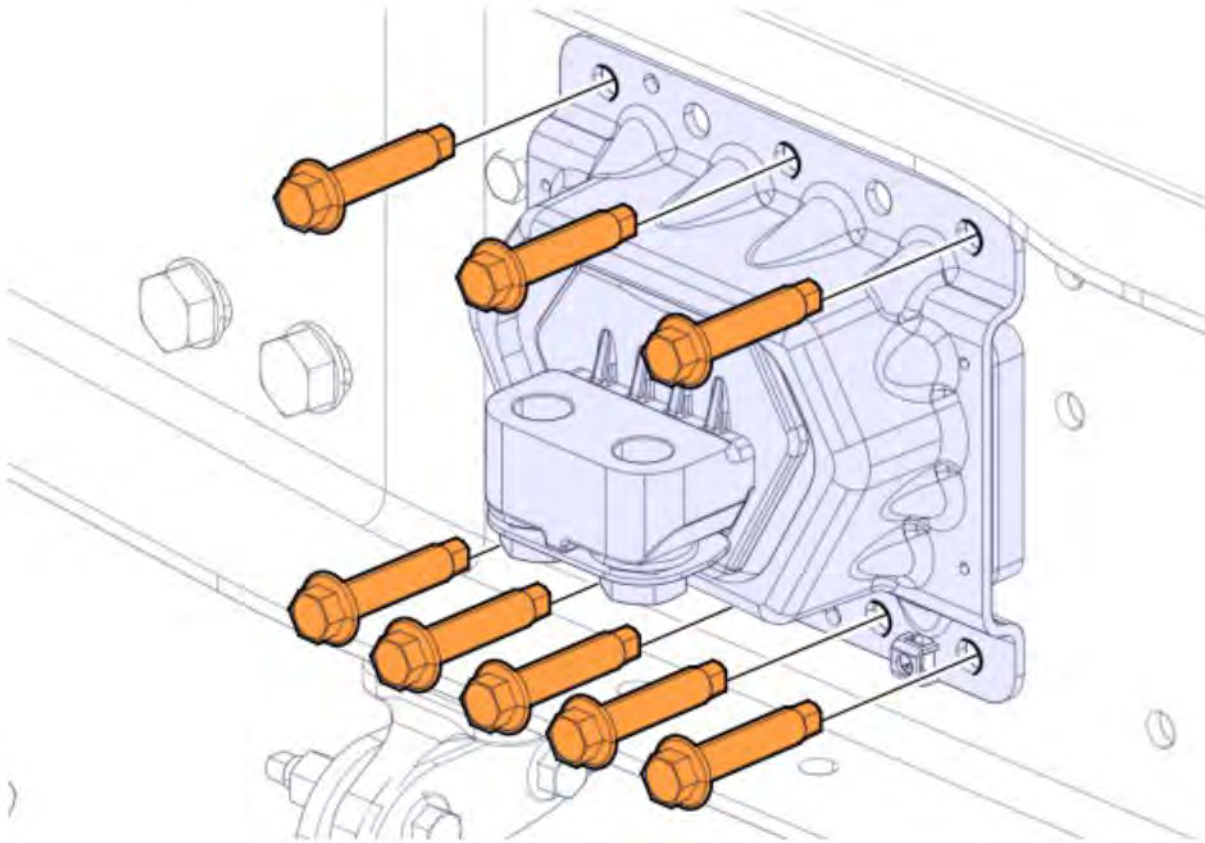

279	Install the nuts.	
280	Torque tighten the nuts.	
	Tightening torque	
	Rear cushion, screw	140 ±25 Nm (103 ±18 lb _f ·ft)

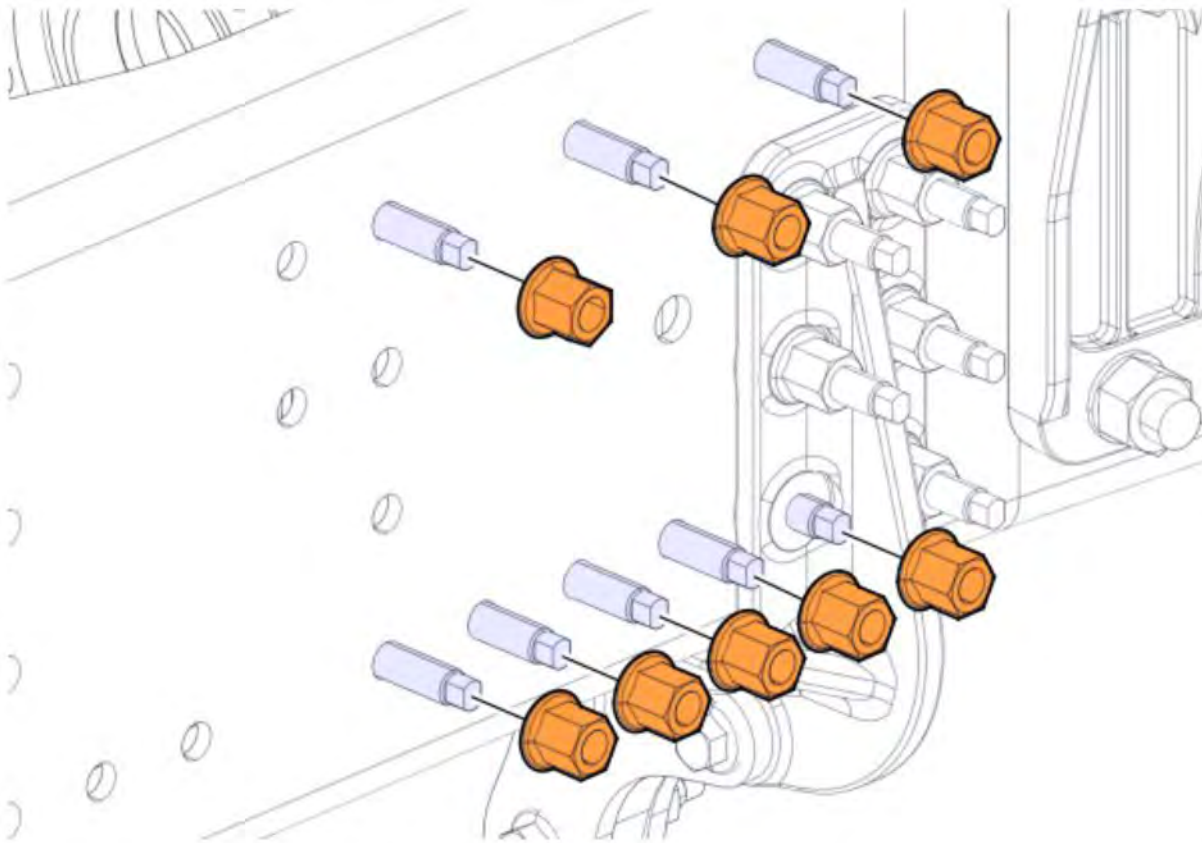

281 Install the rubber cushion.

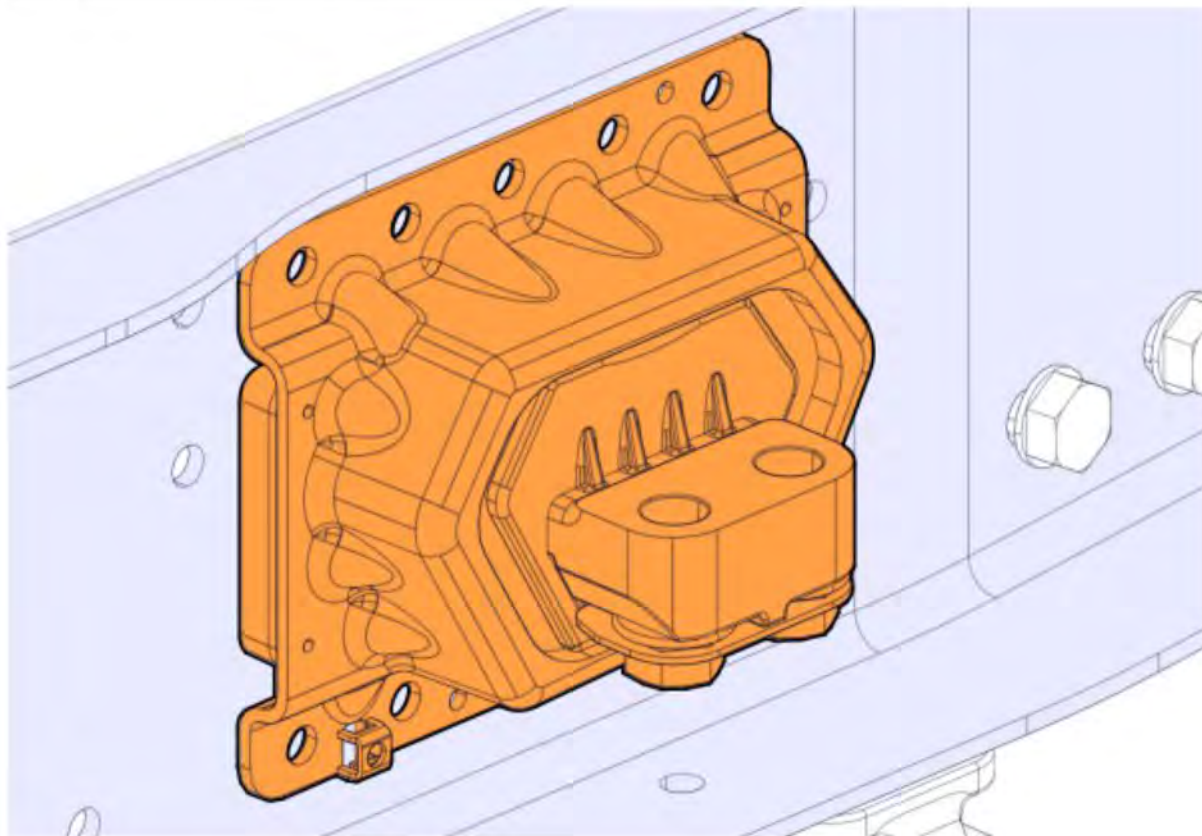

282 Install the screws.

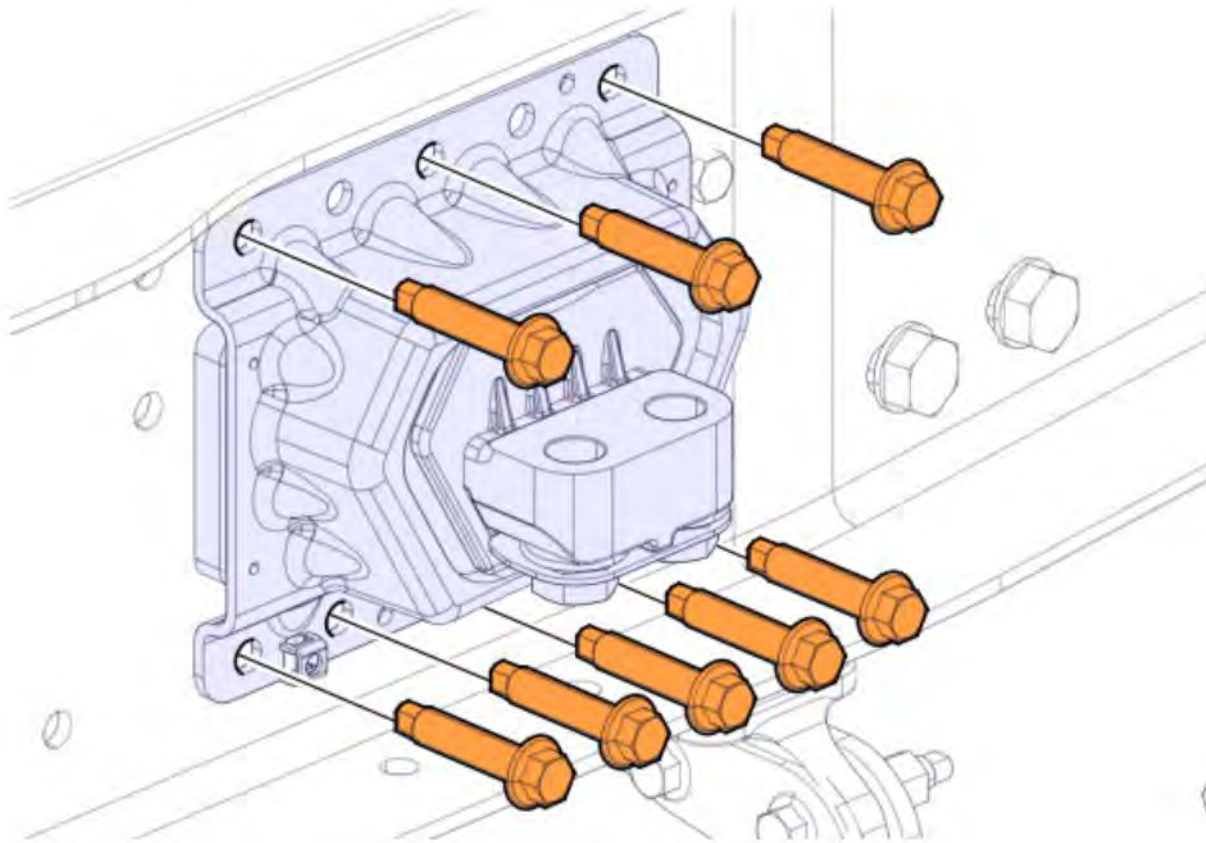

283	Install the nuts.	
284	Torque tighten the nuts.	
	Tightening torque	
	Rear cushion, screw	140 ±25 Nm (103 ±18 lb _f -ft)

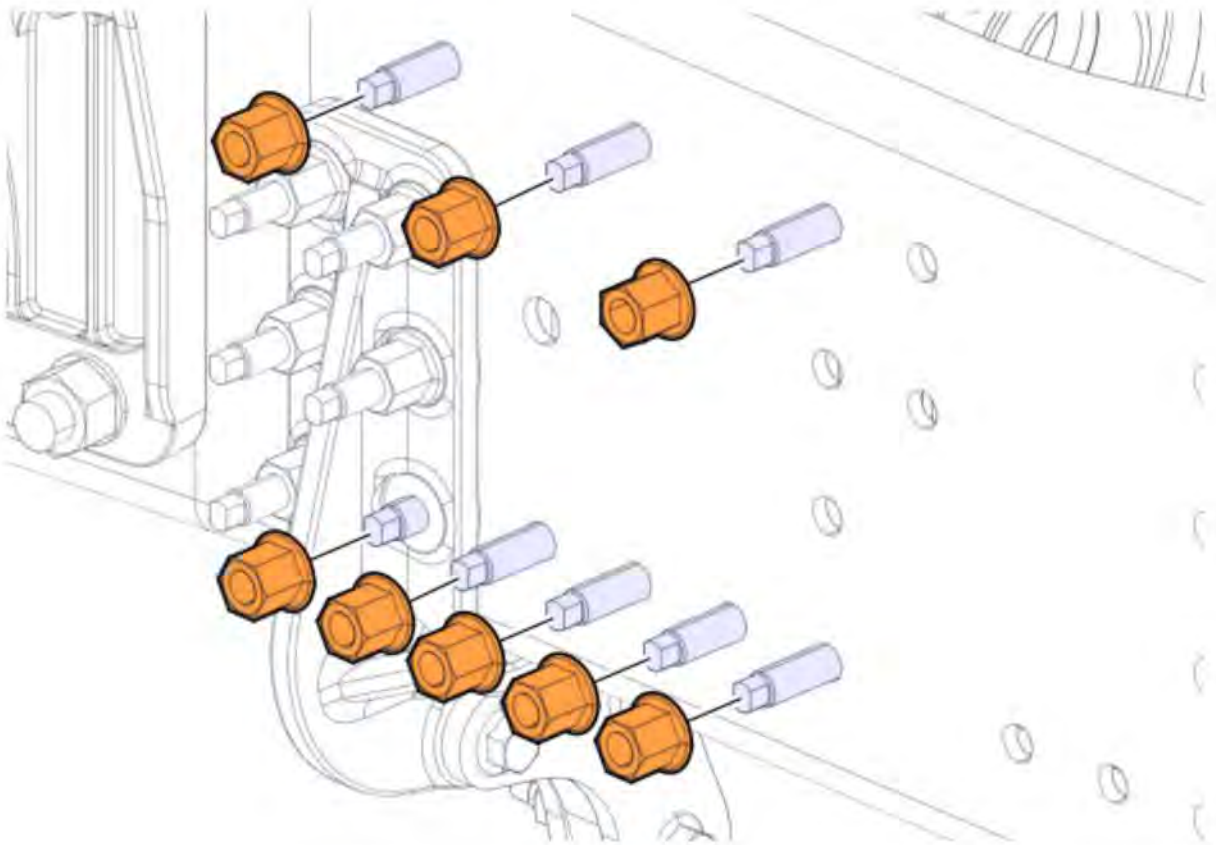

285	Lower the engine onto the rubber cushions.	
286	Install the screws and washers.	
287	Torque tighten the screws.	
	Tightening torque	
	Engine bracket, rubber cushion, screw	540 ±90 Nm (398 ±66 lb _f ·ft)

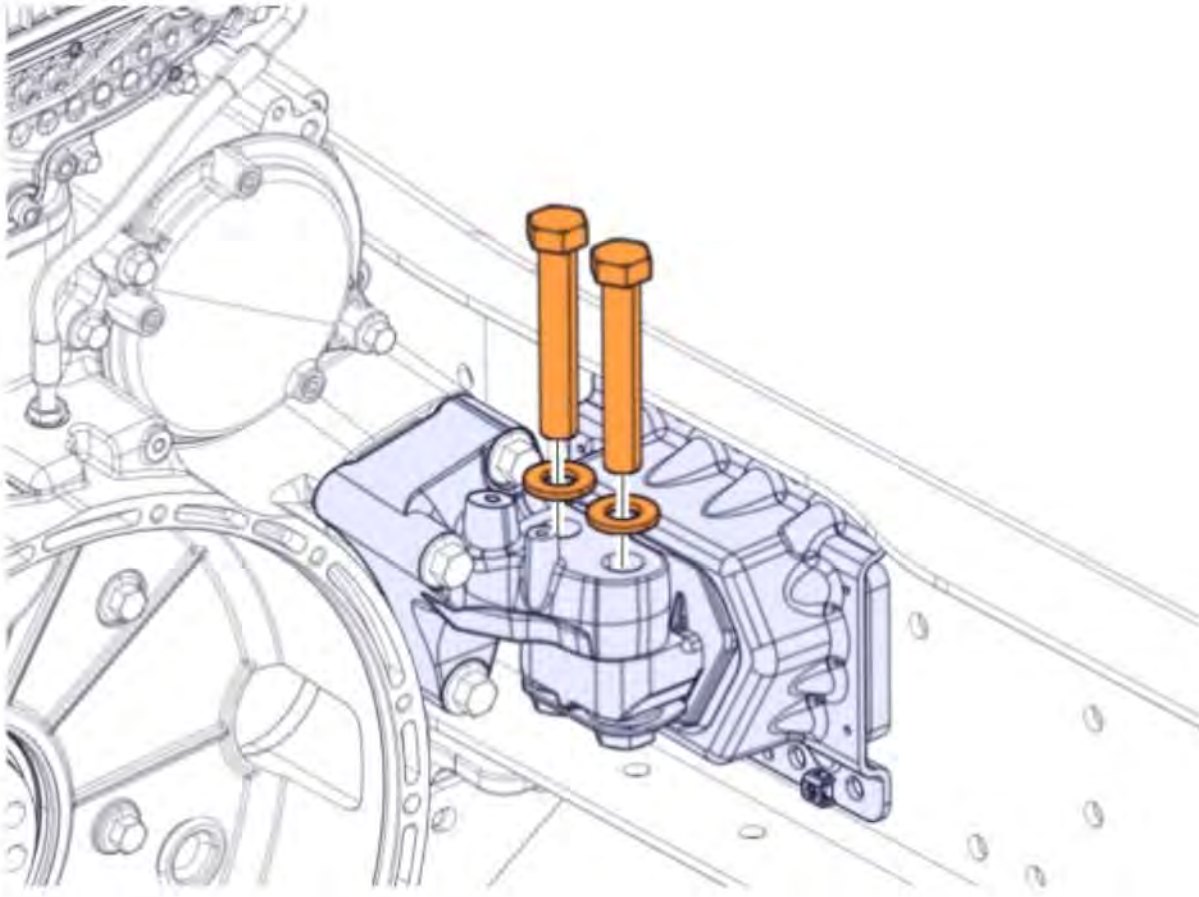

288 Install the screws and washers.

289 Torque tighten the screws.

Tightening torque

Engine bracket, rubber cushion, screw	540 ±90 Nm (398 ±66 lb _f ·ft)
---------------------------------------	---

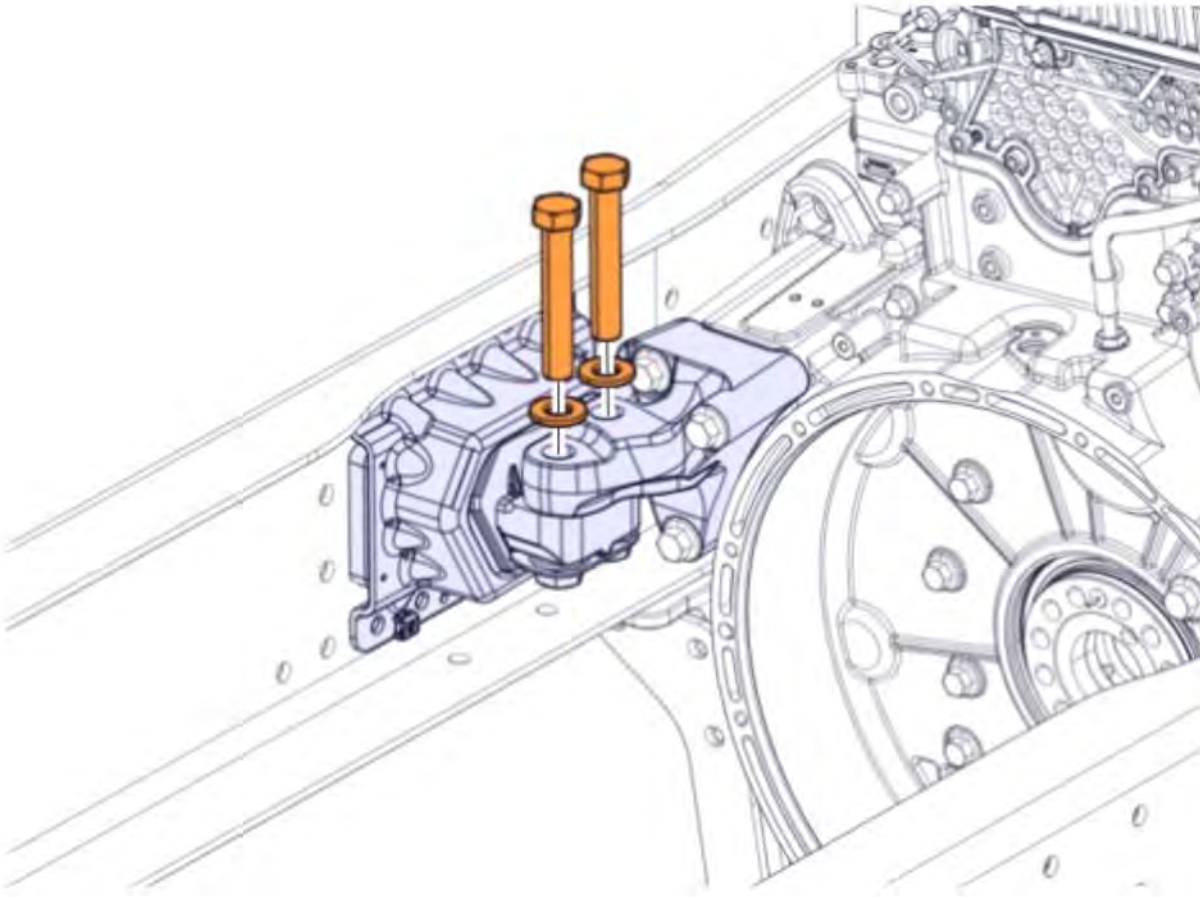

290 Clean the contact surfaces.

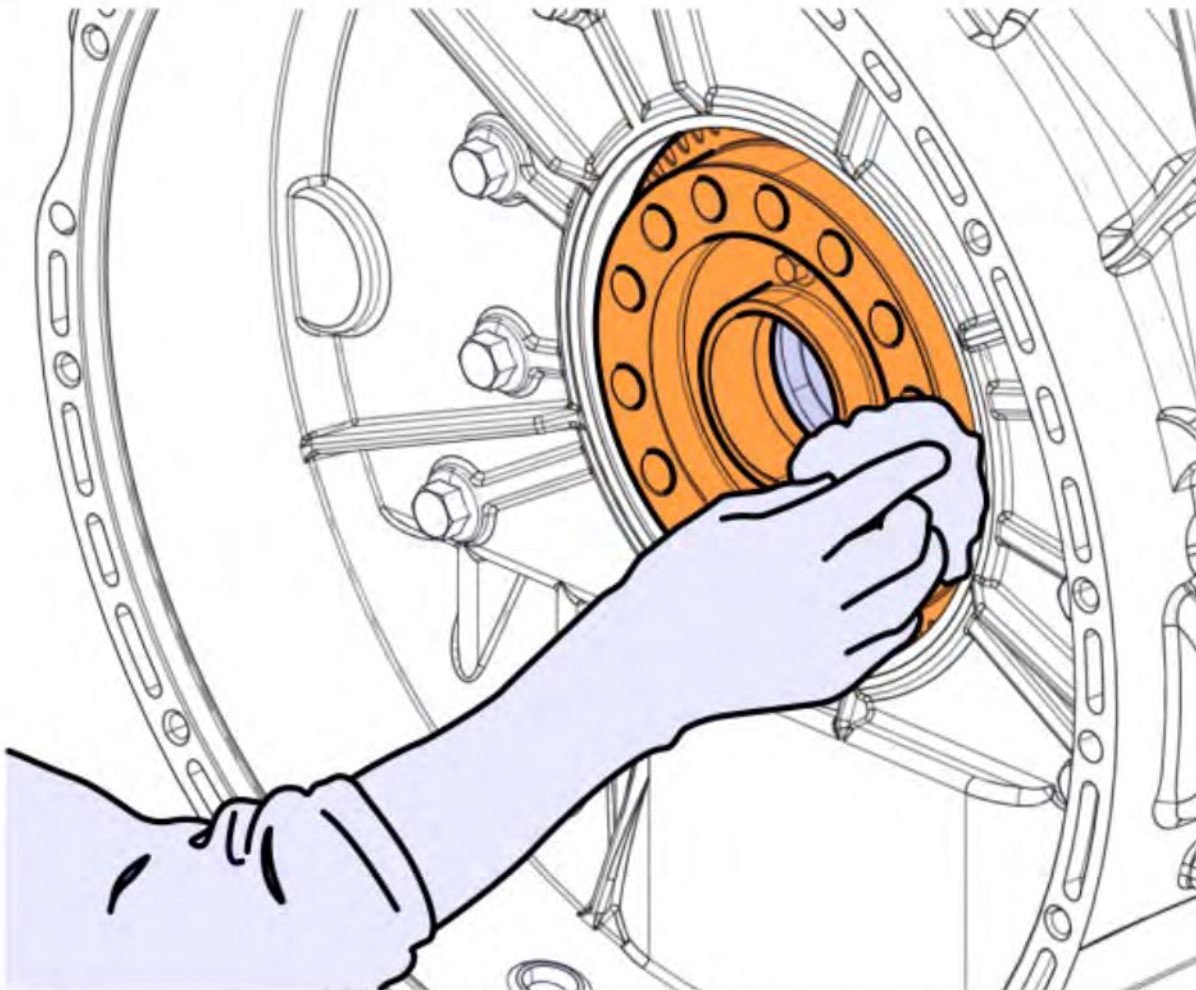



Copyright to this documentation belongs to the Volvo Group. No reproduction, copying, change, amendment or other similar disposal is entitled without prior written consent by the Volvo Group

The information contained herein is current at the time of its original distribution, but is subject to change. The reader is advised that printed copies are uncontrolled.

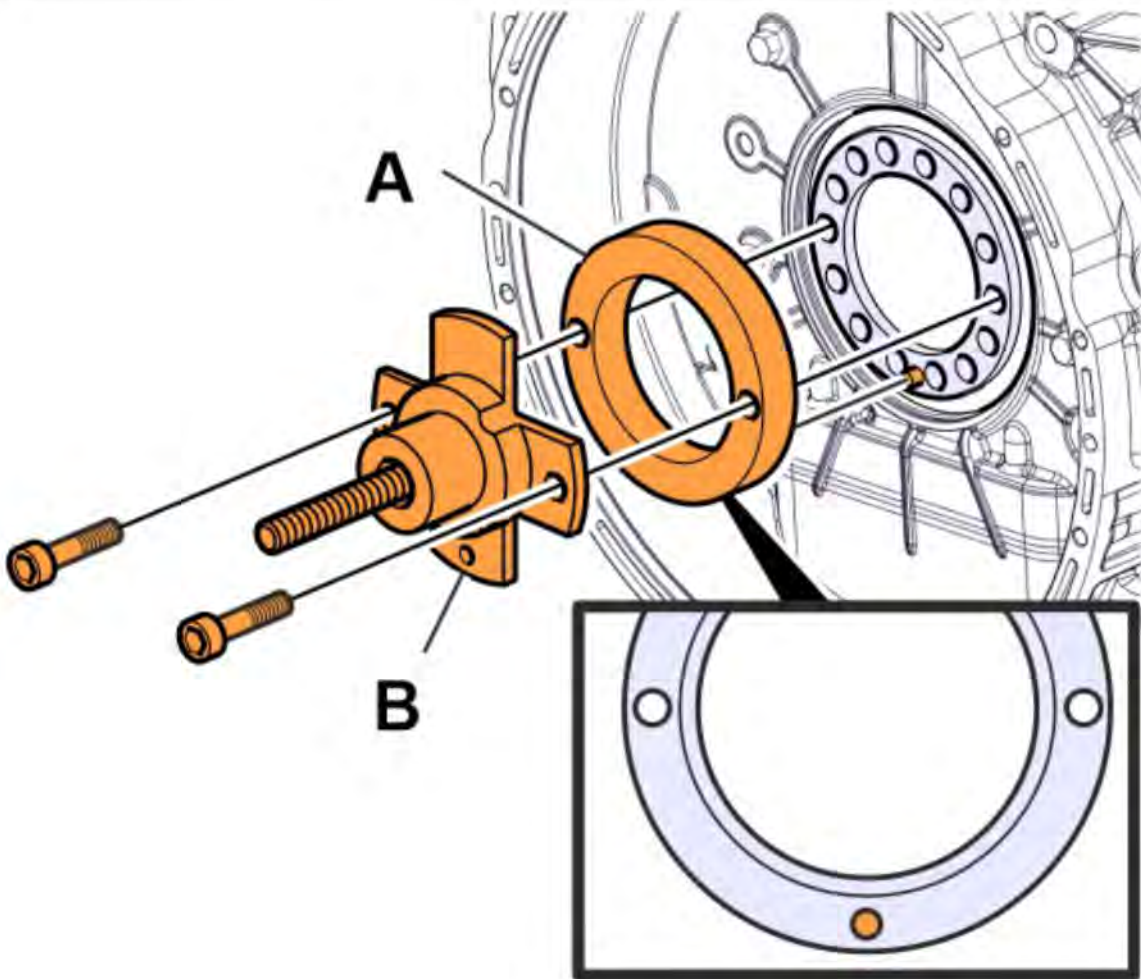
291	Install the spacer and the tool on the crankshaft.	
292	Install the screws.	
	Required material	
	A	ASSEMBLY TOOL 88800619
	B	ASSEMBLY TOOL 9990166
	Service hint Ensure that the spacer and the tool are properly positioned on the crankshaft's internal guide and are flat against the crankshaft before tightening the screws.	



293	Position the seal.	
		Note Always use a new type of seal.
		Note Lubricate the seal to facilitate installation.
	Service hint The text on the seal must be turned away from the engine.	

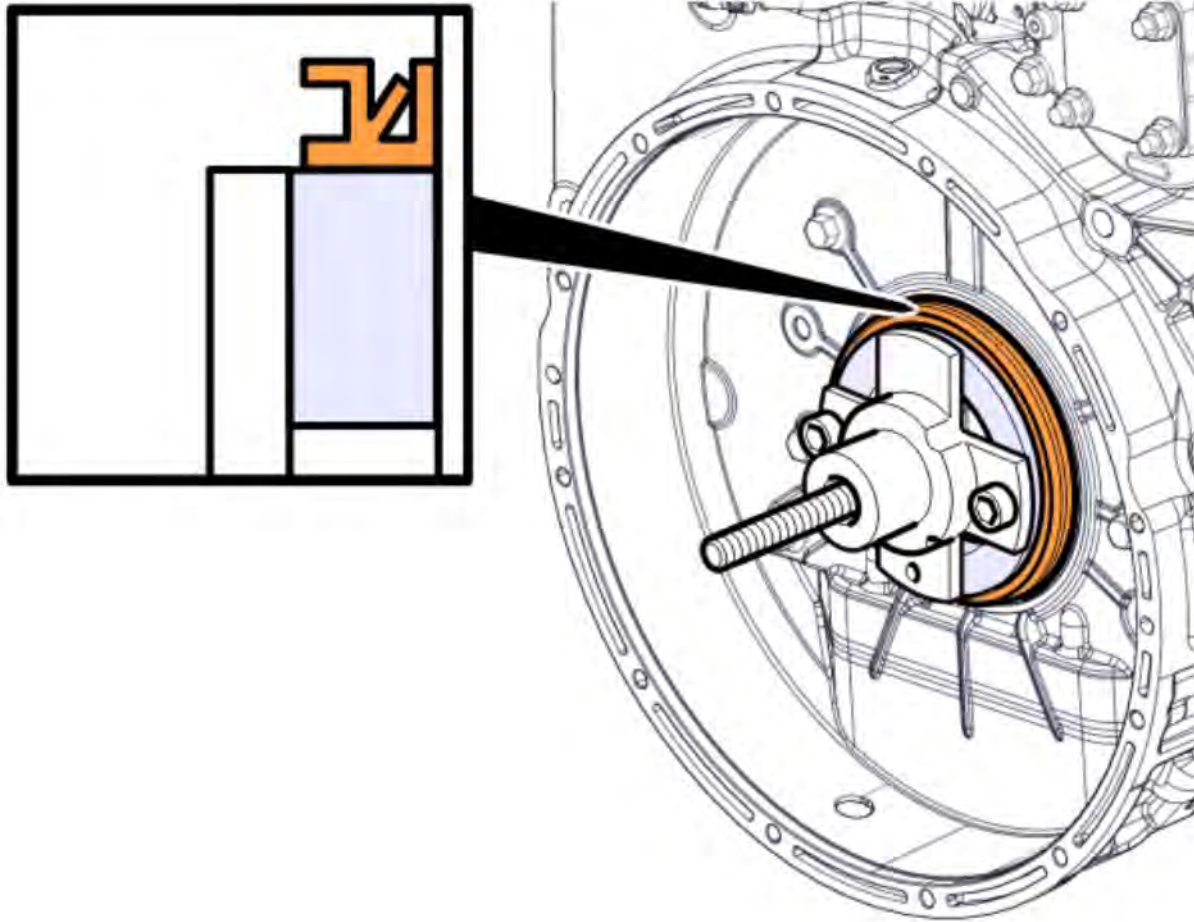

294	Install the installation tool.		
	Required material		
	A	ASSEMBLY TOOL	88800619
	B	ASSEMBLY TOOL	9990166
	C	Seal	

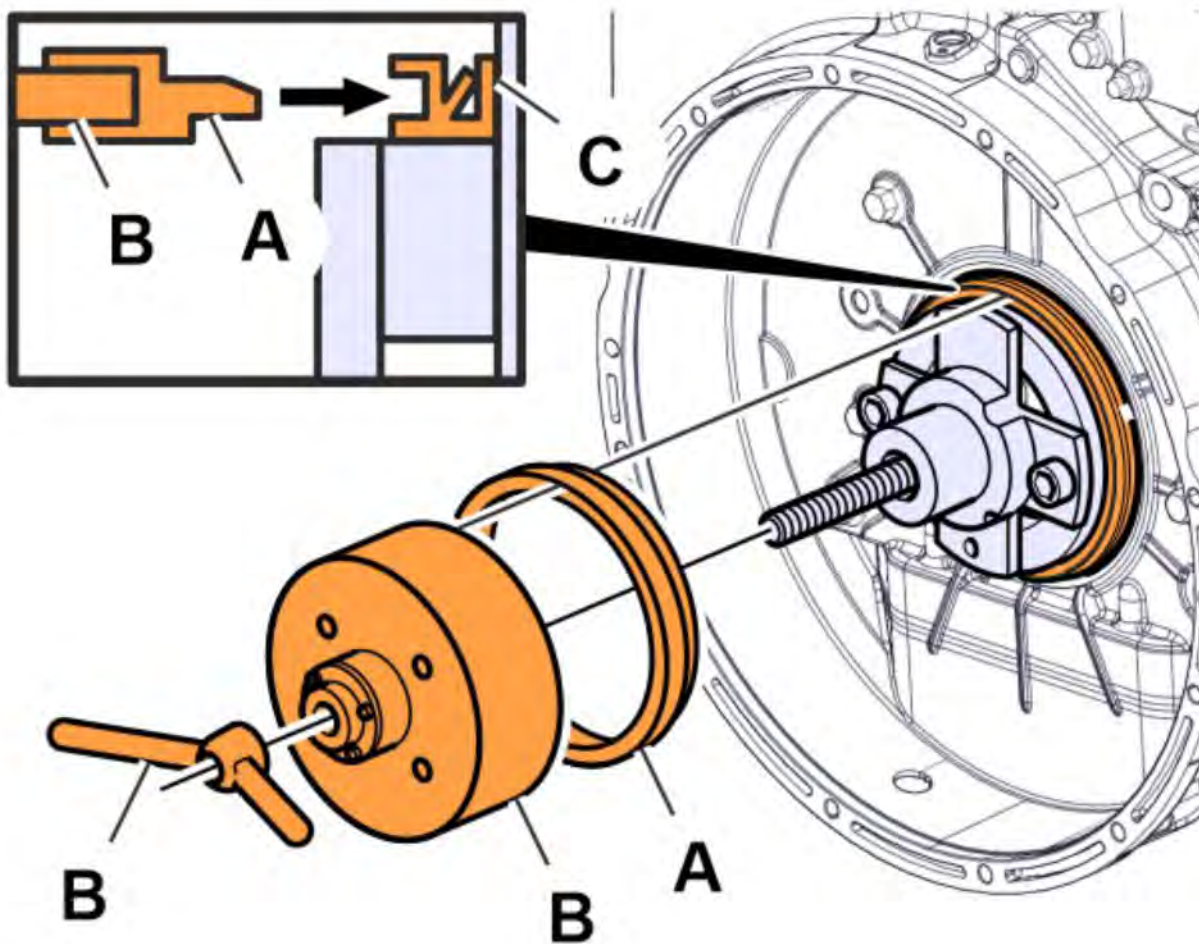

295 Press the cassette seal into place by turning the handle.



Note

The cassette seal is correctly located in the flywheel housing when the tool bottoms out.

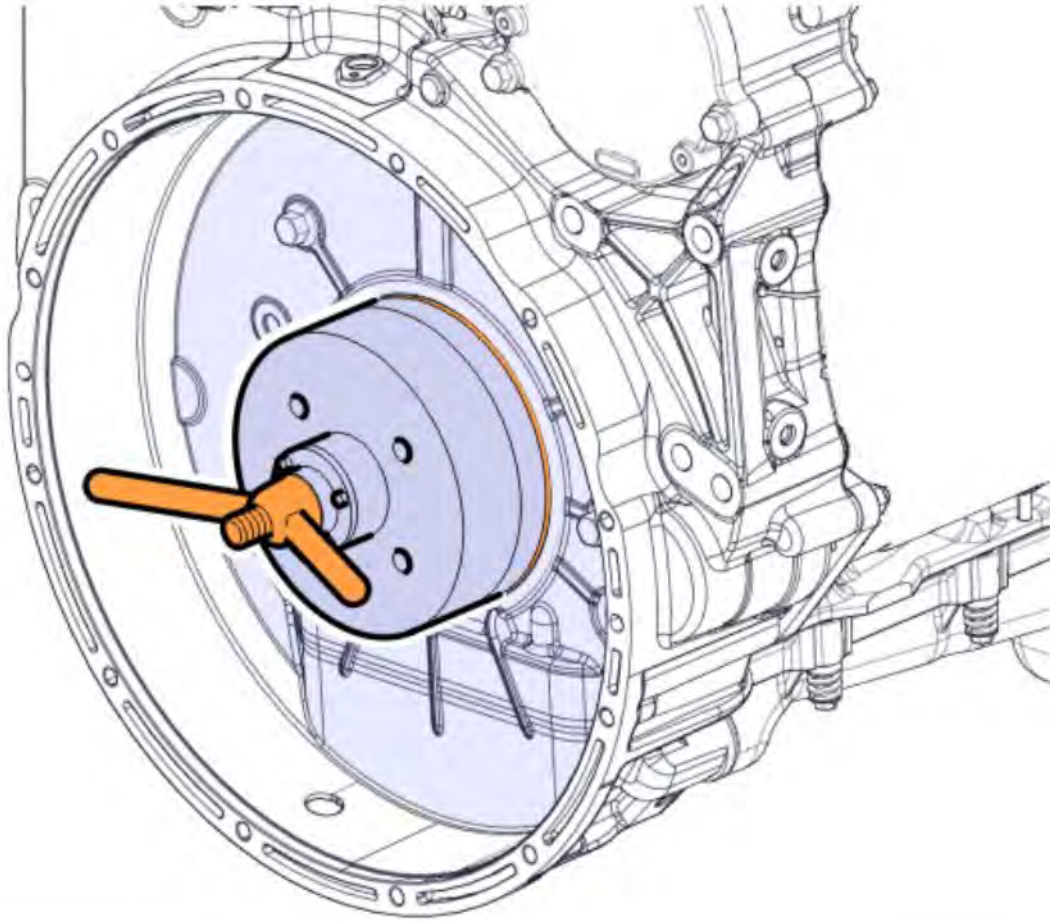

296	Remove the adapter and cover.
-----	-------------------------------

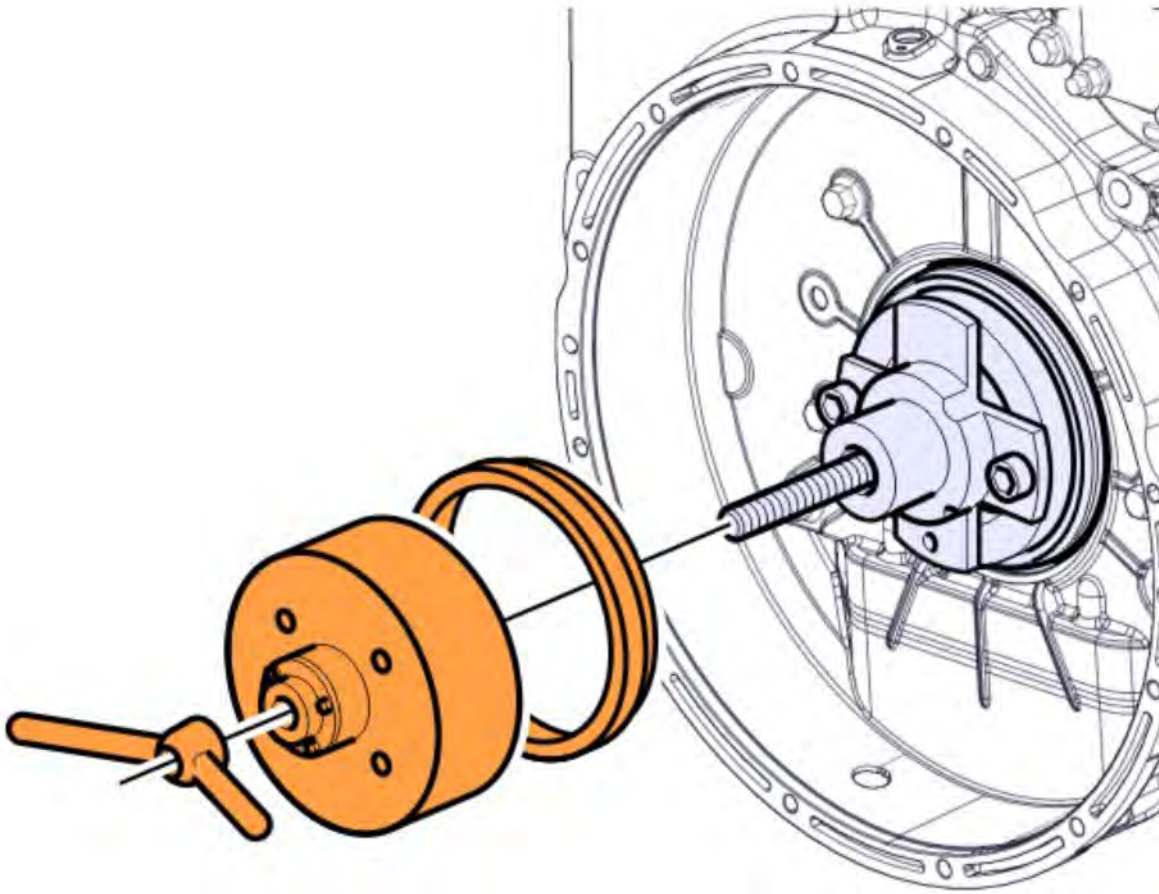

297	Remove the tool and the spacer.
-----	---------------------------------

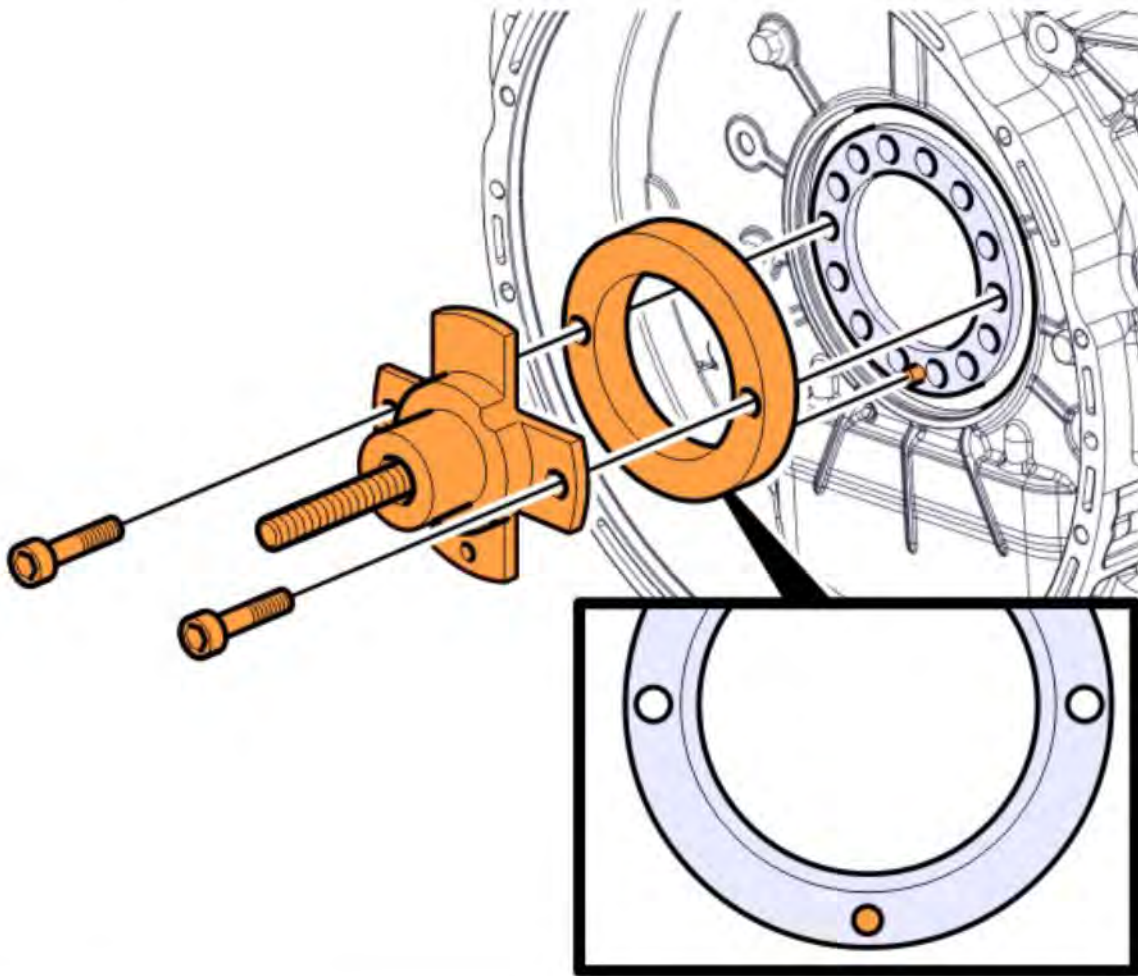

298 Fill the filters with engine oil.



Note

Use new filters.

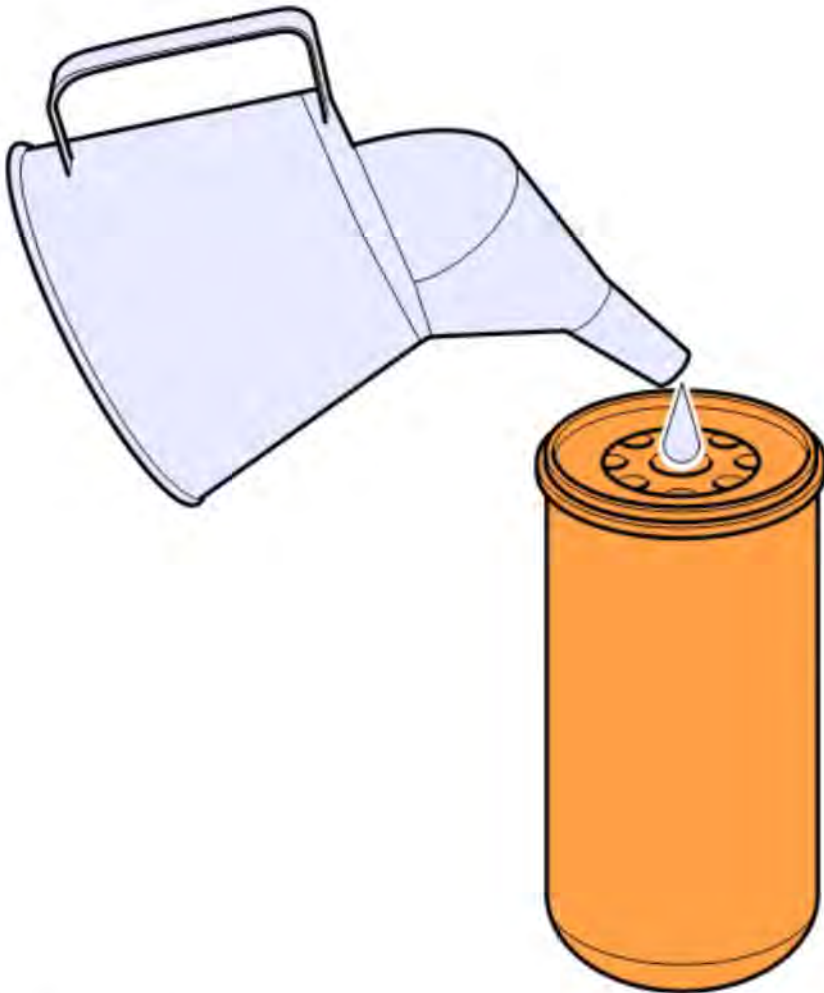

299 Apply engine oil to the gasket.



Note

Use recommended oil.



300 | Install the filters.

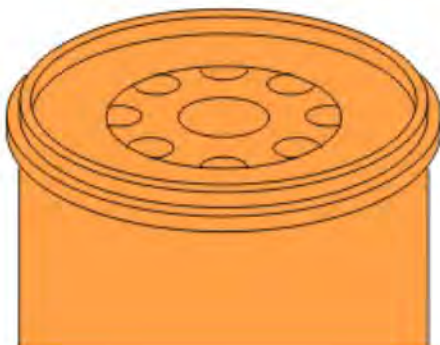
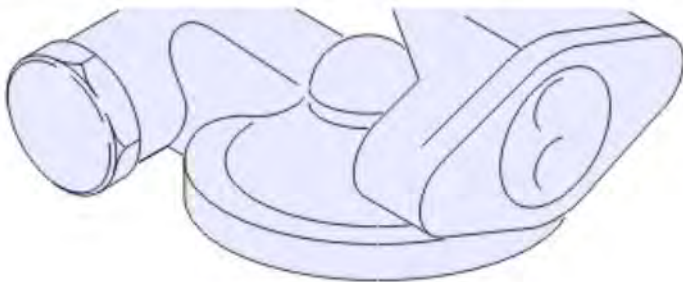

!
DANGER

Risk of material damage, serious personal injury or death.
 Connections that are not tightened in accordance with specified tightening torques may cause leakage.

- ▶ Tighten connections according to service information.

301	Torque-tighten the filters.	
	Tightening torque	
	Oil filter	25 ±5 Nm (18 ±4 lb _f .ft)

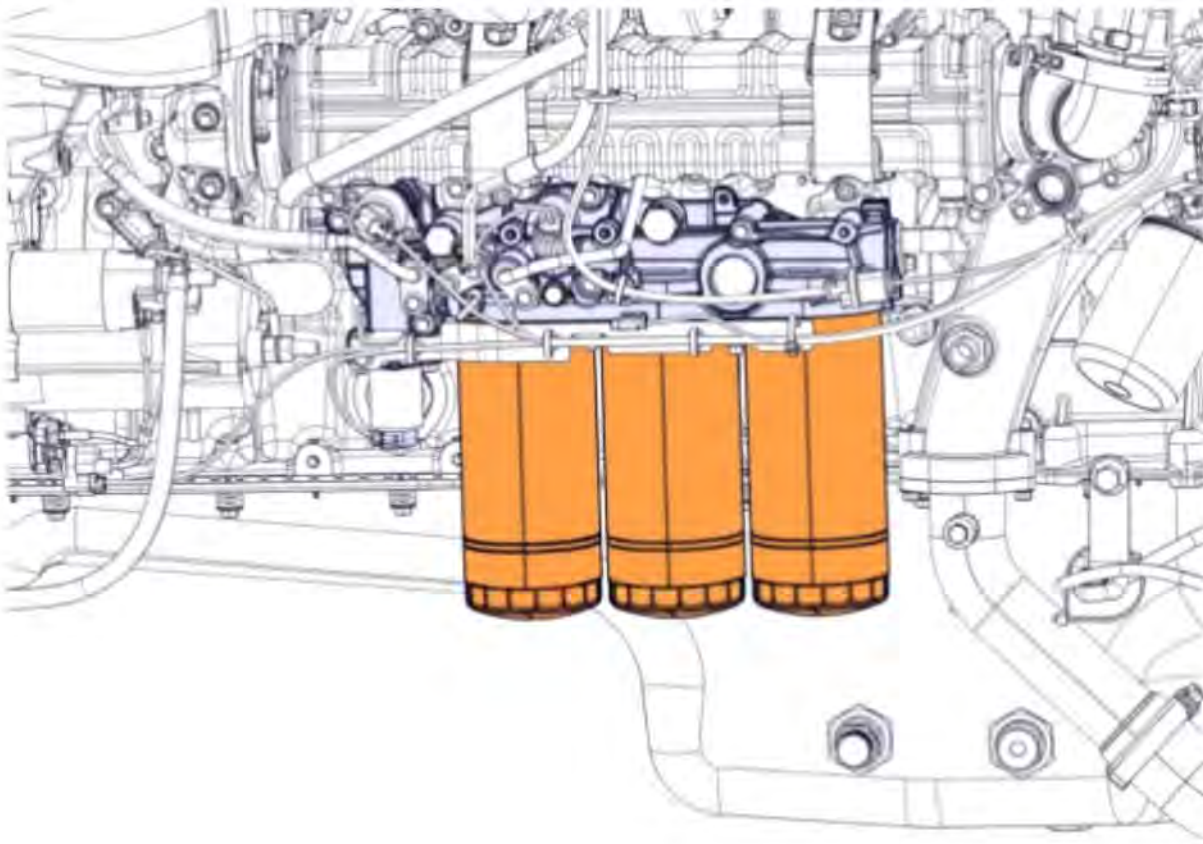

302	Clean the contact surfaces.	
	i	Note Ensure that the surfaces are completely clean of oil and grease

303	Remove hardened sealant.
------------	--------------------------

304	Apply recommended sealant as illustrated.	
	Tech data	
	Sealant, bead thickness	2 mm

Copyright to this documentation belongs to the Volvo Group. No reproduction, copying, change, amendment or other similar disposal is entitled without prior written consent by the Volvo Group

The information contained herein is current at the time of its original distribution, but is subject to change. The reader is advised that printed copies are uncontrolled.

(0.08 in)

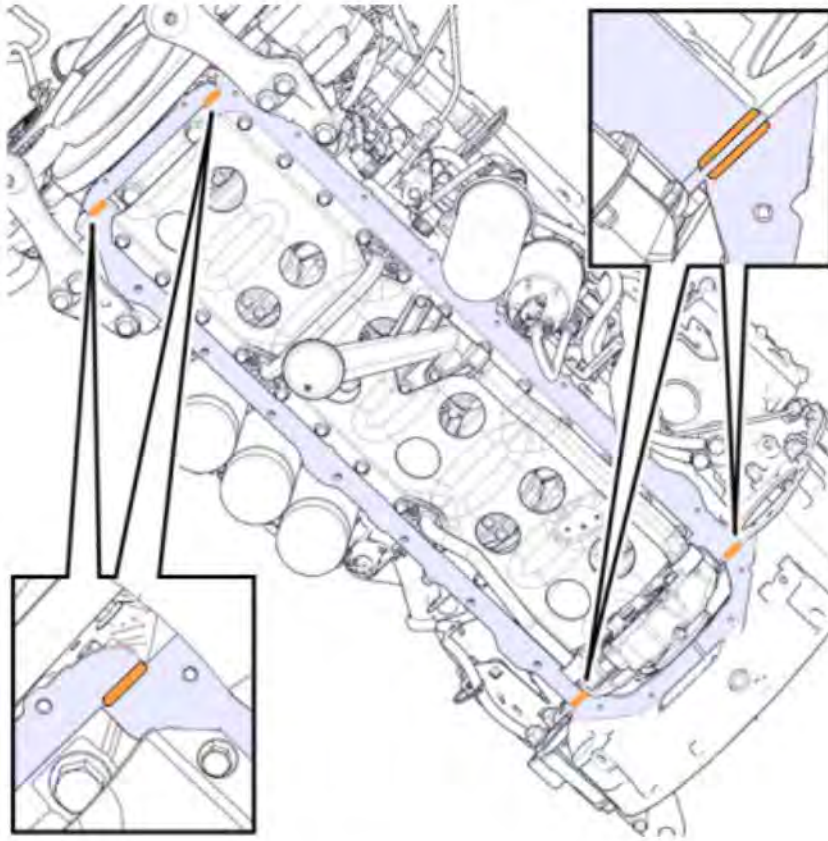

305 Install the gasket.

**Note**

Use a new part.

**Note**

Install the gasket within 20 minutes of sealant application.

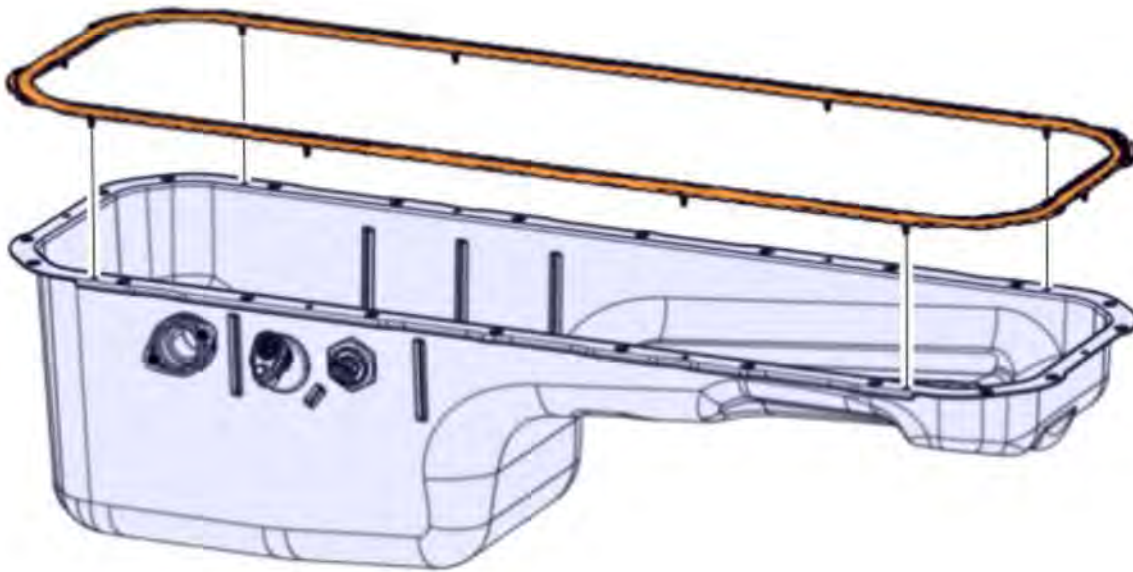

306 Install the oil pan.



Note

Assistance may be required.

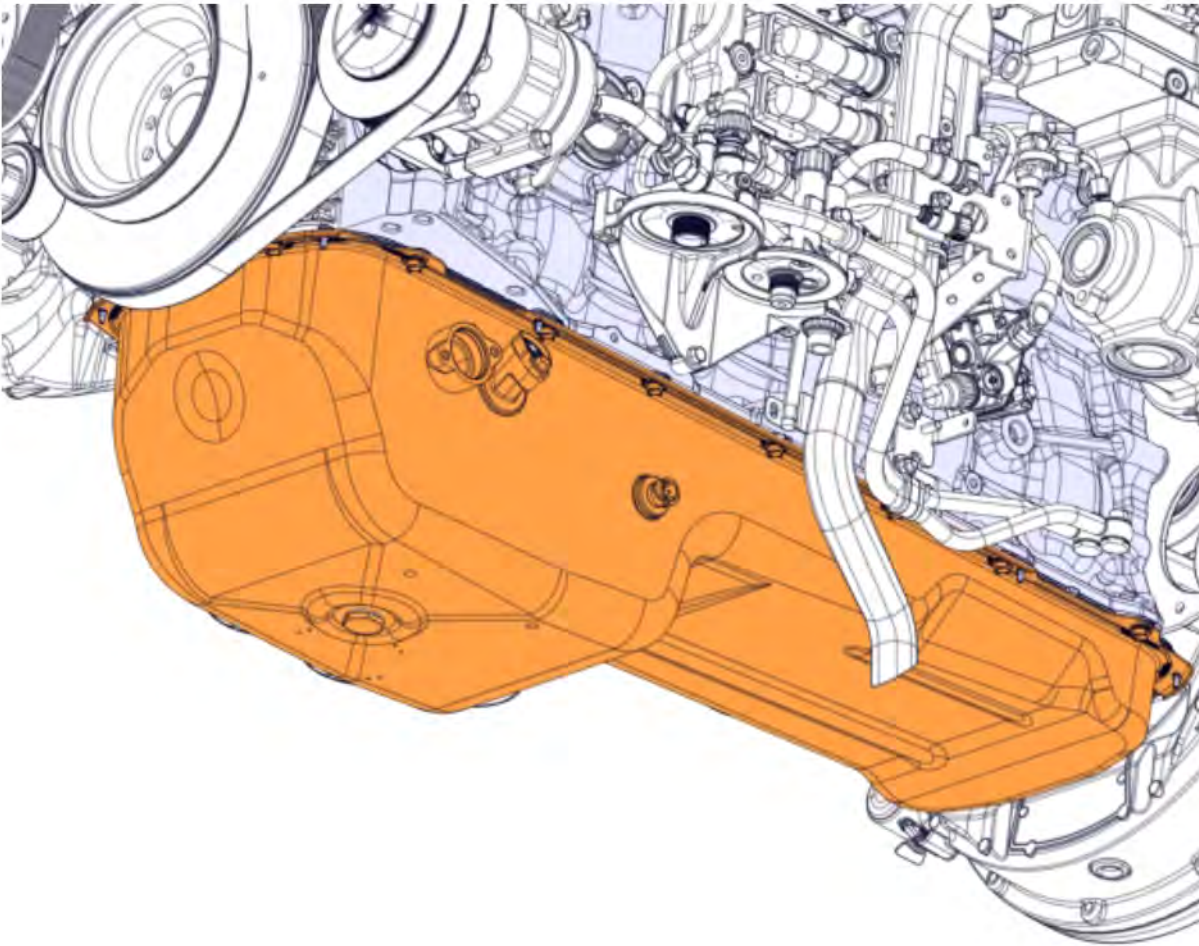

307	Install the screws.
-----	---------------------



308 Torque tighten the screws.

Tightening torque	
Oil pan, screw	Tightening sequence: 1-22
	24 ±4 Nm (18 ±3 lb _f -ft)

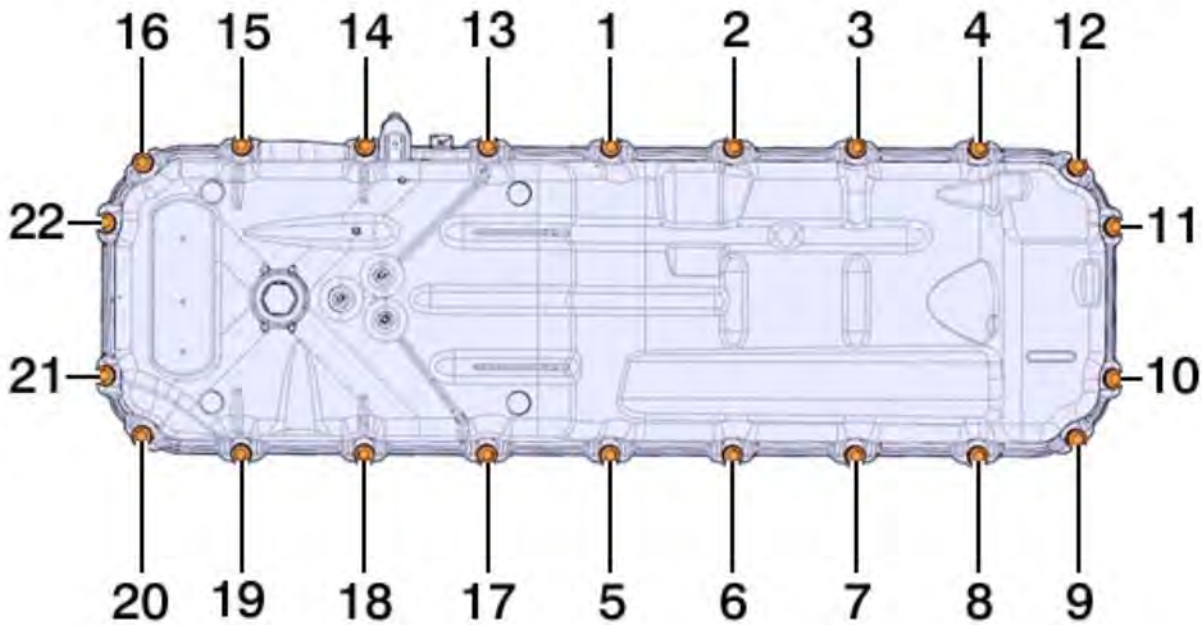

309 Install the seal.

i	Note Use a new part.
----------	--------------------------------

310 Install the pipe (A).

311 Install the outer casing (B).

i	Note Check the outer casing for correct position.
----------	---

312 Connect the connector (C).



313 This step contains 2 alternatives.

Select one of the valid alternatives below.

Alternative 1 / 2

▶ Clean the crankshaft flange.

▶ Check the crankshaft seal.



▶ Install the flywheel.

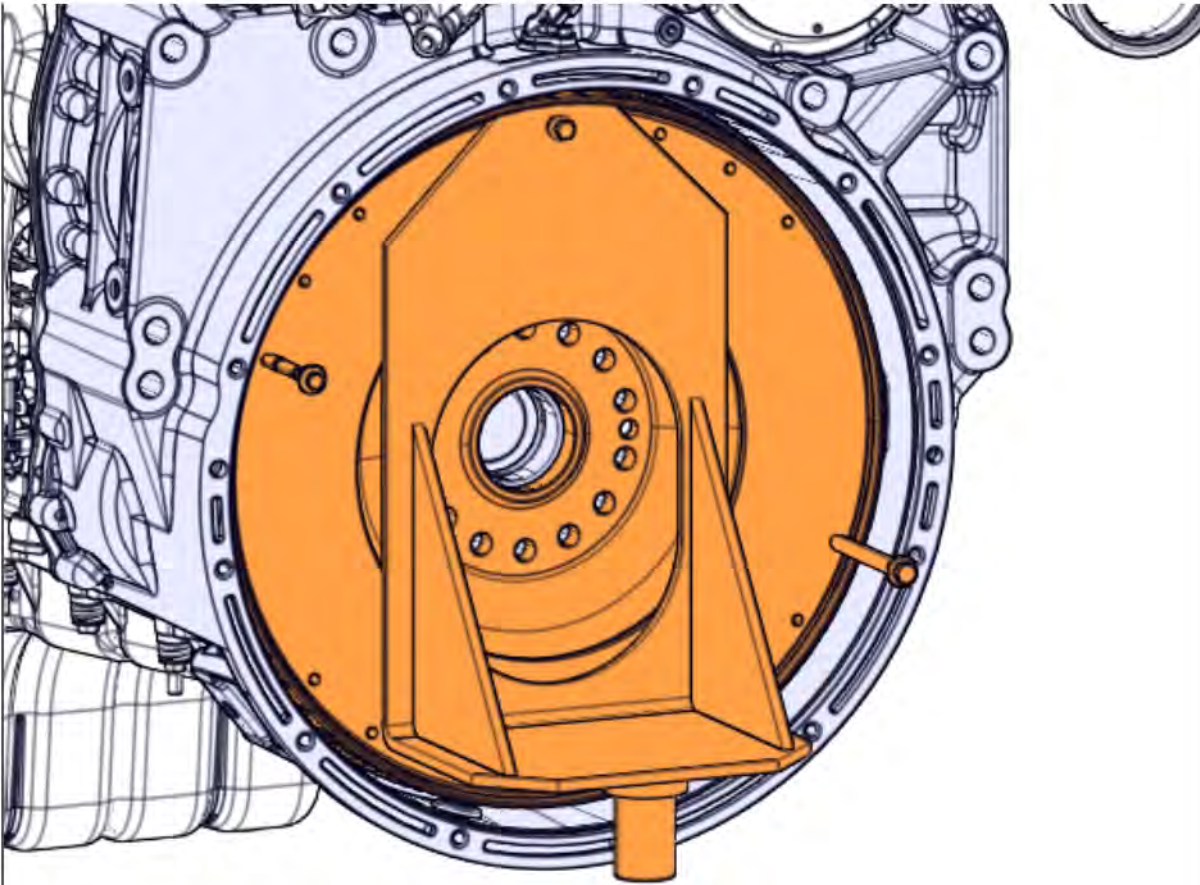

- ▶ Install the screws.

**Note**

Hand tighten the screws.

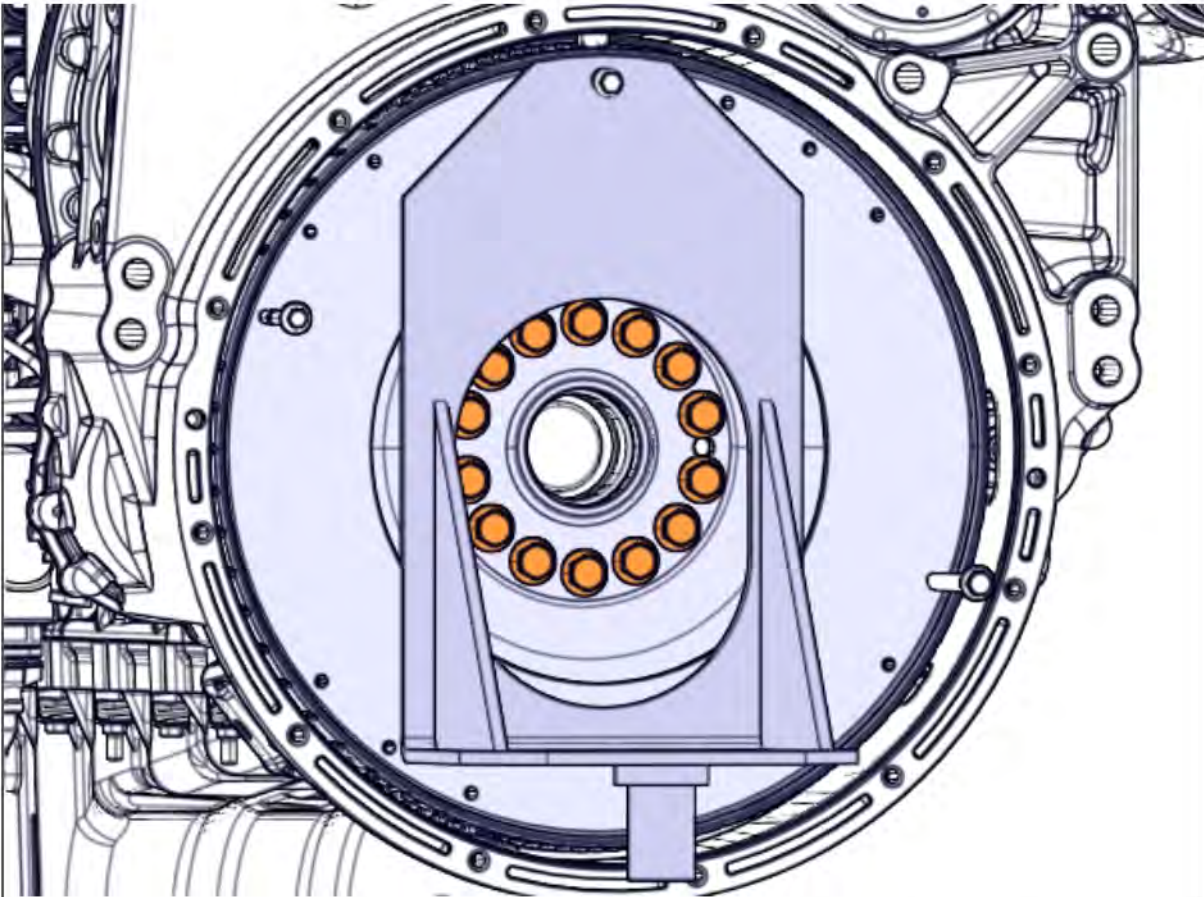

► Remove the screws.

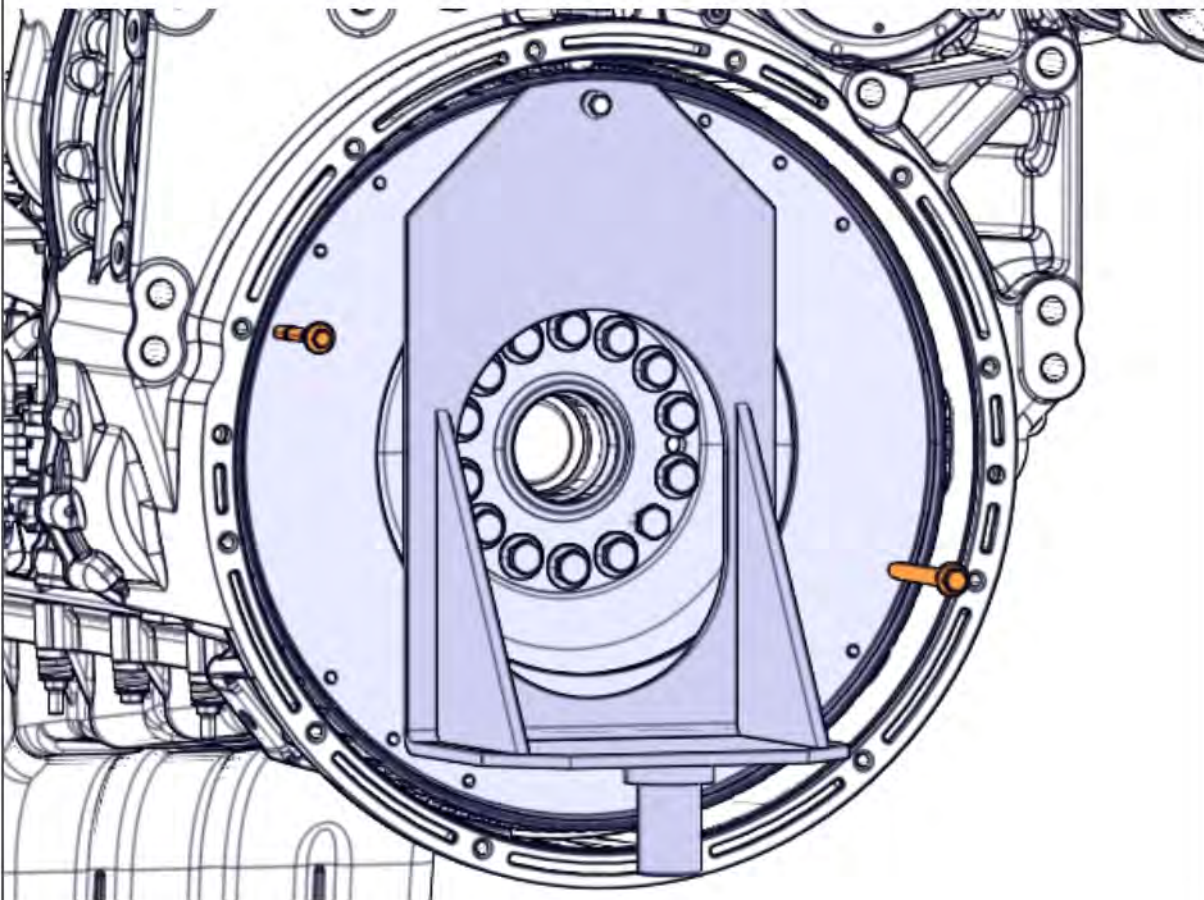

► Remove the screw.

▶ Remove the tool.

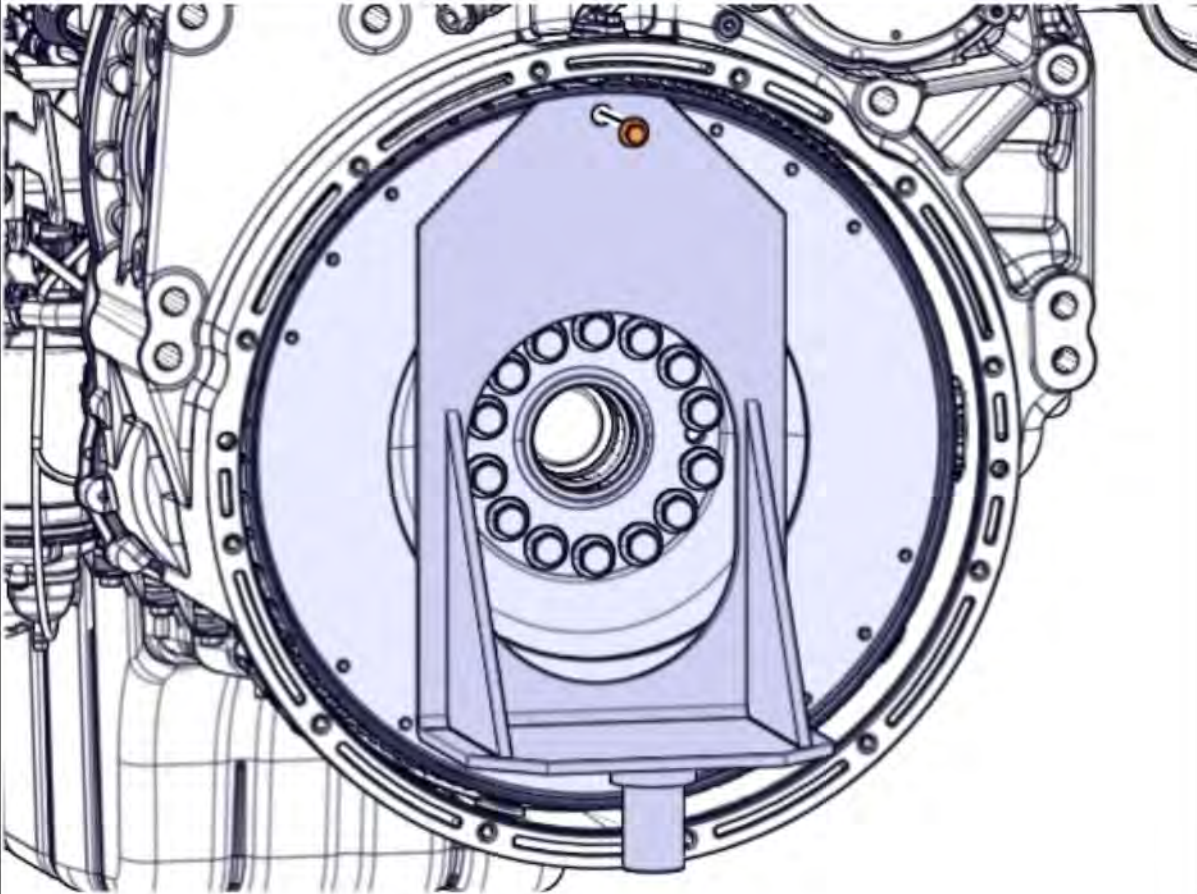

Alternative 2 / 2

▶ Clean the crankshaft flange.

▶ Check the crankshaft seal.



▶ Install the flywheel.

▶ Install the flexplate.

▶ Install the thrust plate.

▶ Install the screws.



Note

Hand tighten.

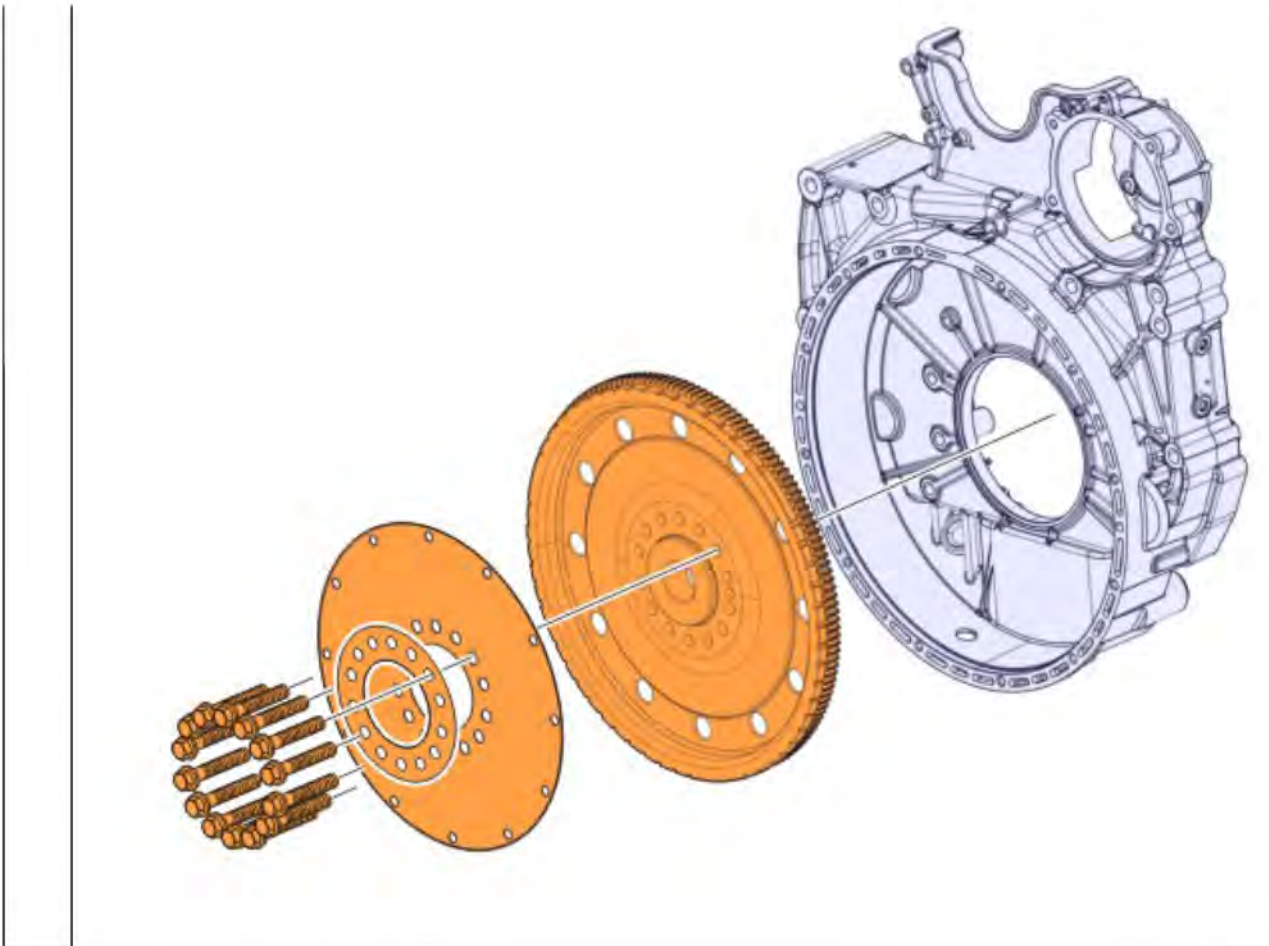

314 Install the cranking tool (A).

Required material

CRANKING TOOL	88840317
---------------	--------------------------

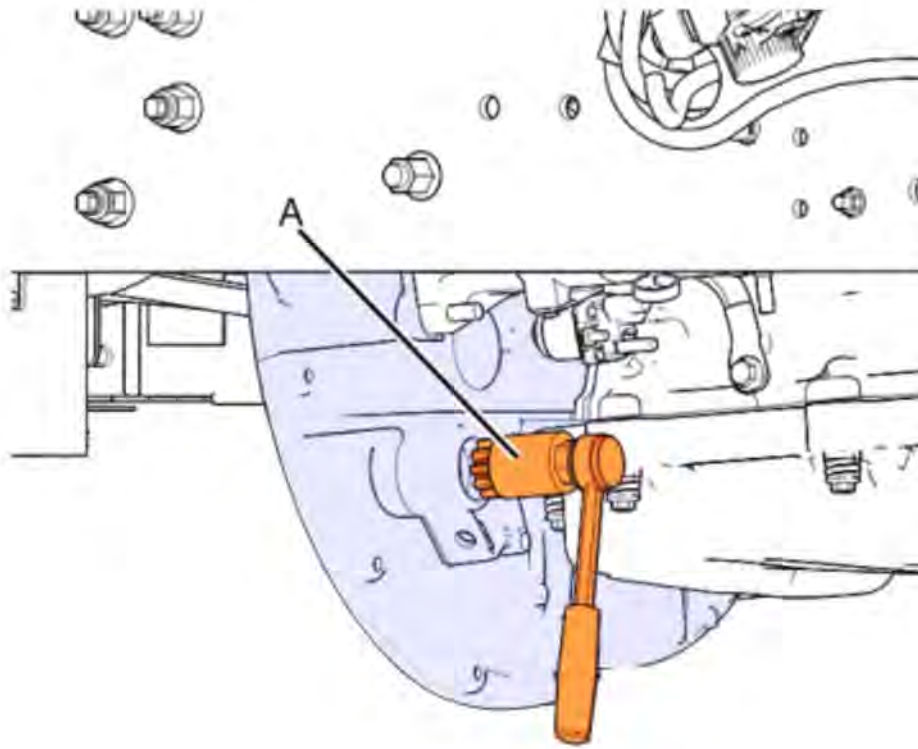

315 Torque tighten the screws.

Tightening torque		
Flywheel, screw	1.	Tightening sequence: 1-14
		60 ±5 Nm (44 ±4 lb _f .ft)
	2.	Tightening sequence: 1-14
		120 ±10°

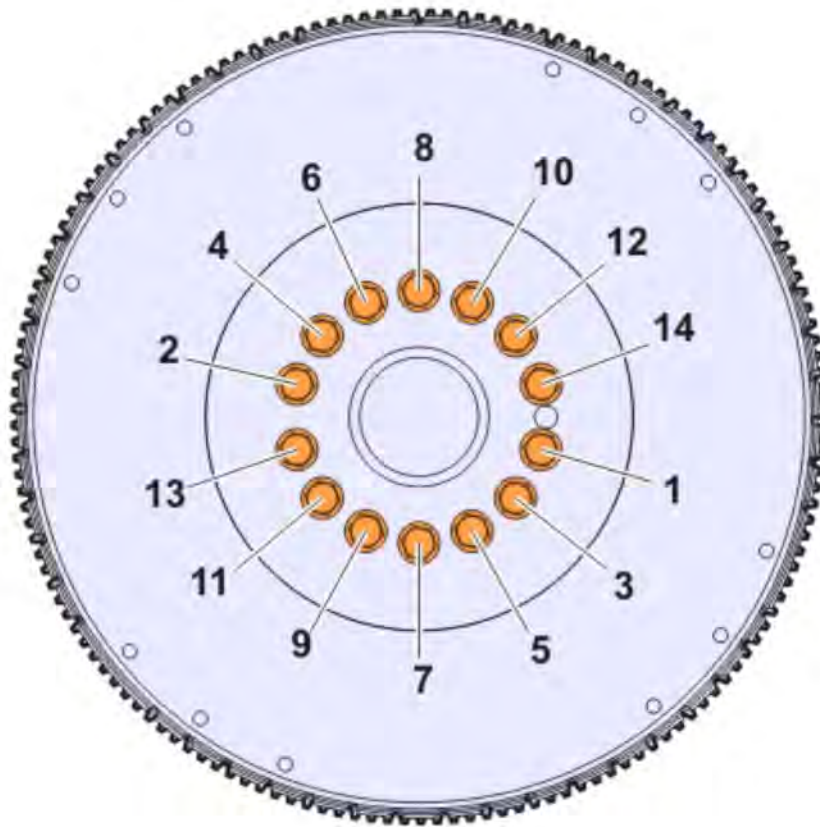

Note

Use the cranking tool with a drawbar handle as counterhold.

316 Clean the contact surfaces.

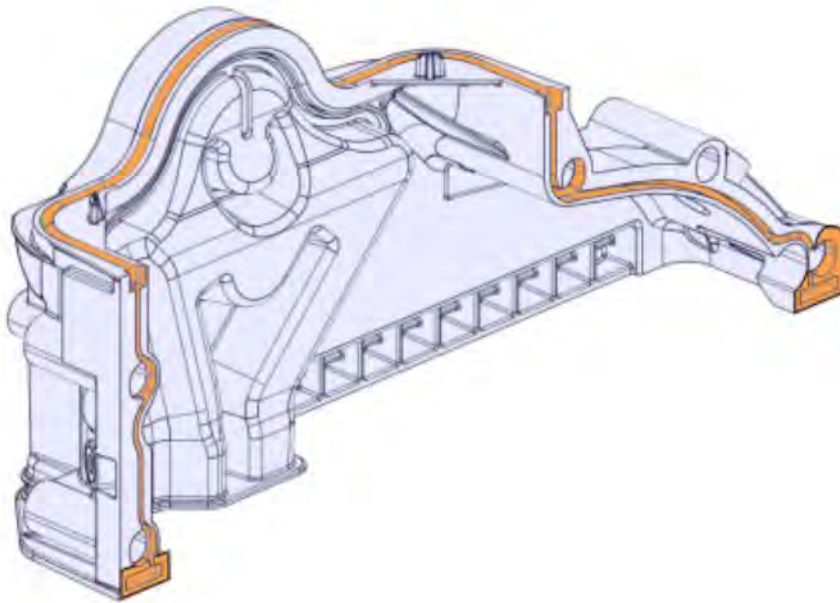

317 Install the gasket.



Note

Use a new part.

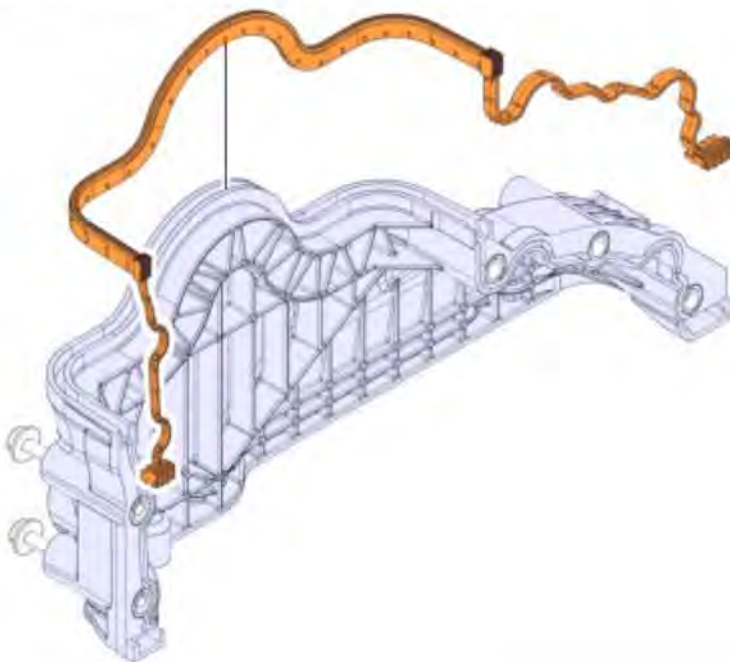

318 Clean the contact surfaces carefully.

319 Install the timing gear cover.



Note

Take care not to damage the gasket.

Note

Copyright to this documentation belongs to the Volvo Group. No reproduction, copying, change, amendment or other similar disposal is entitled without prior written consent by the Volvo Group

The information contained herein is current at the time of its original distribution, but is subject to change. The reader is advised that printed copies are uncontrolled.



Check that the gasket is correctly located in the groove.

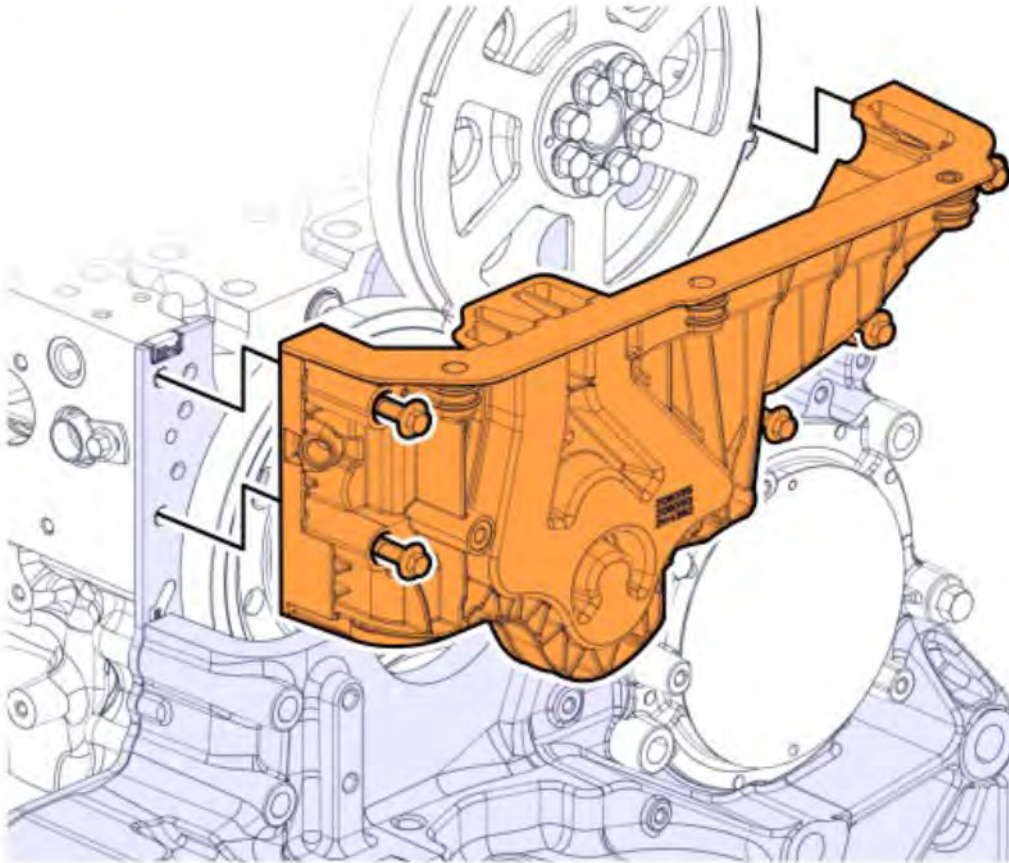

320	Install the tools.	
	Required material	
	ALIGN TOOL	85111422

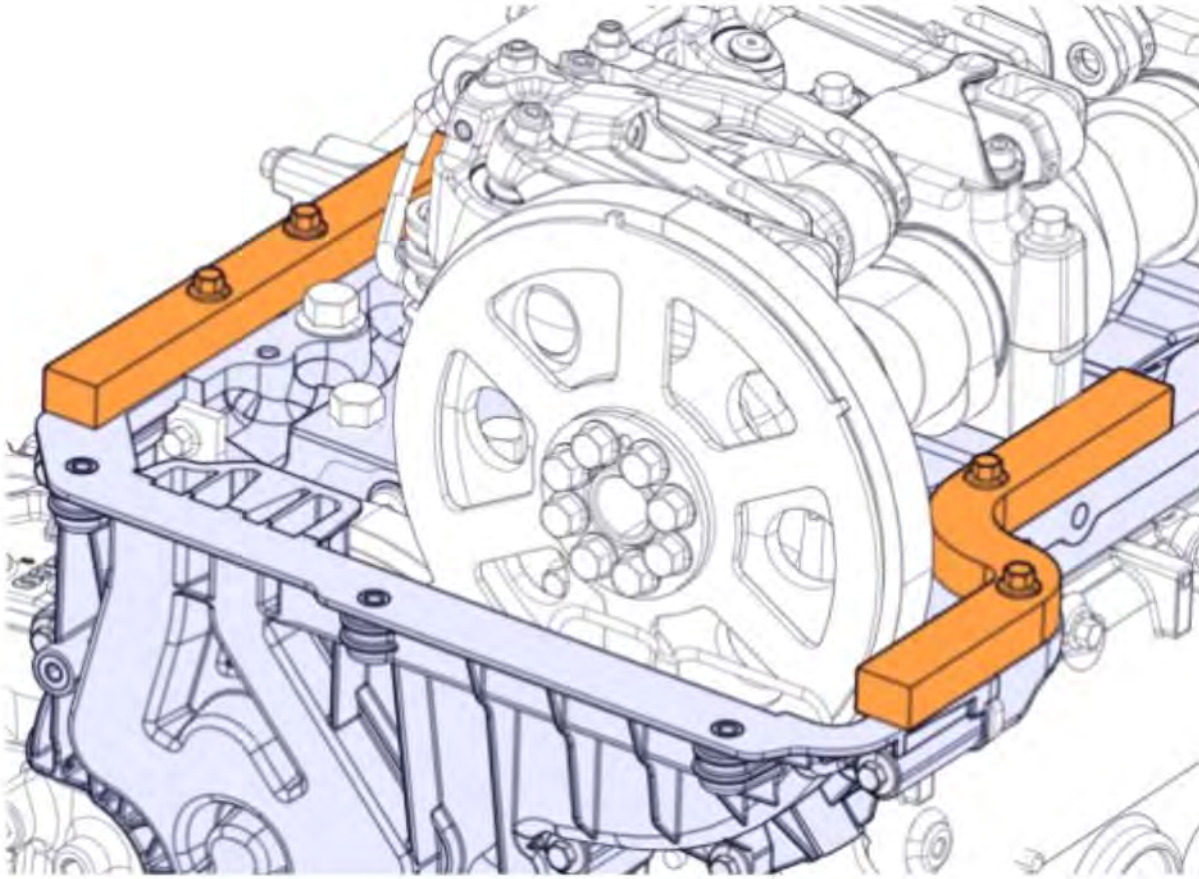

321 Gently tighten the timing gear cover screws.



Note

Ensure that the timing gear cover aligns with the cylinder head on both sides.



Note

Ensure that the timing gear cover is in contact with the timing gear plate.

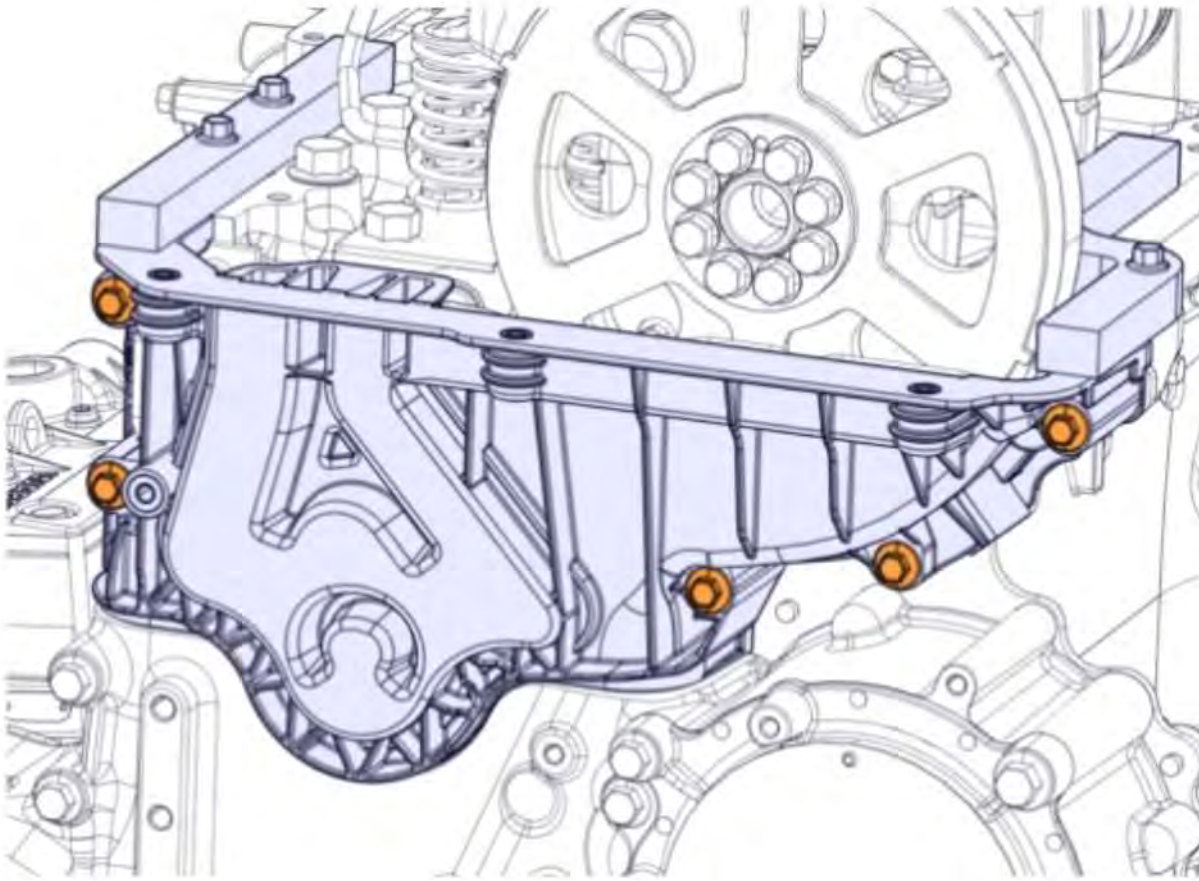

322 Torque tighten the screws.

Tightening torque	
Upper timing gear casing, screw	Tightening sequence: 1-5
	27 ±3 Nm
	(20 ±2 lb _f ·ft)

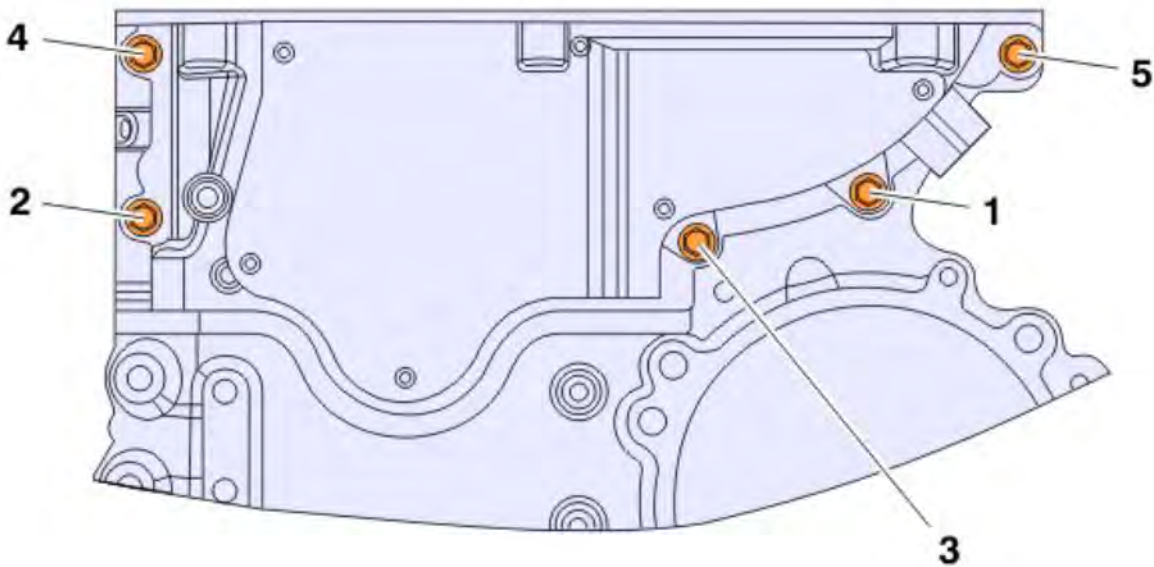

323 Remove the tools.

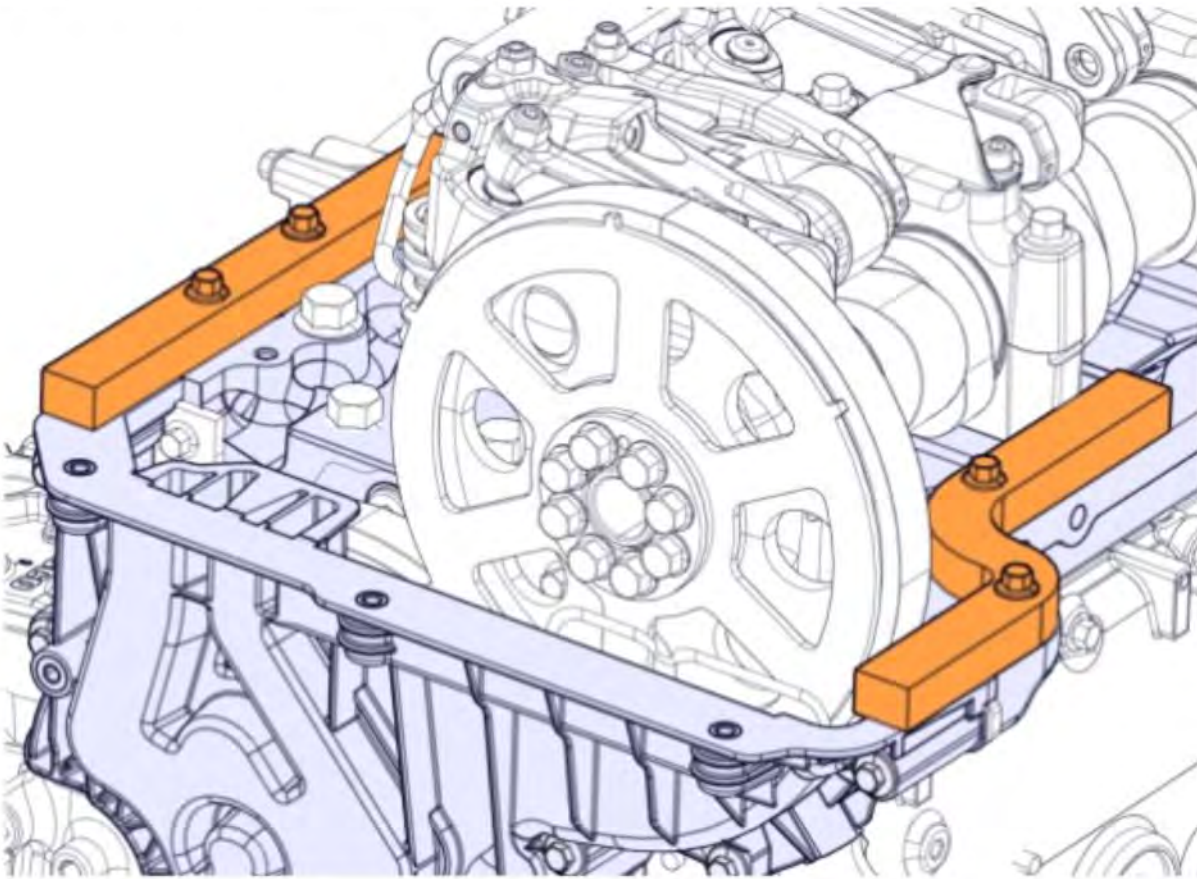

324 Rotate the gear so that a tooth on the sensor wheel aligns with the sensor location.

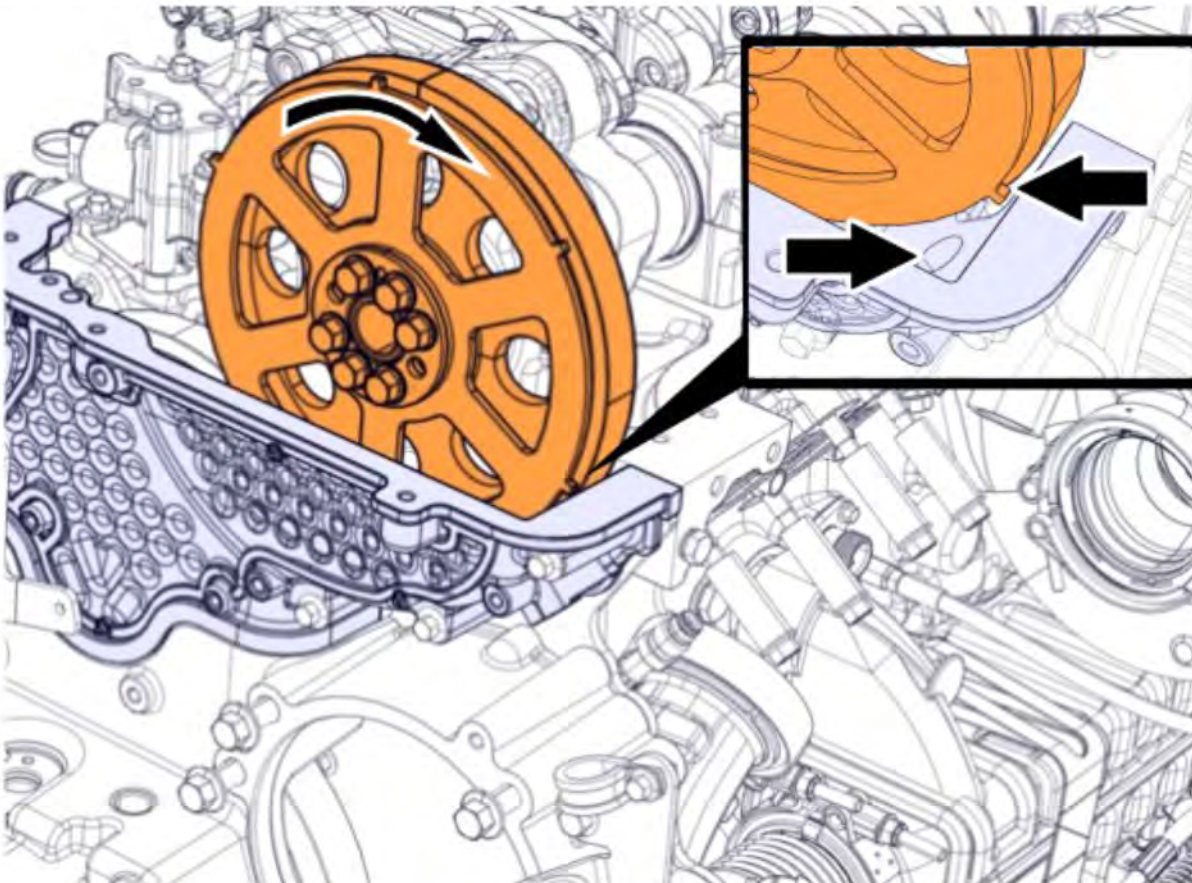

325	Install the setting tool.
Required material	
SETTING TOOL	88800031

326	Read off the setting tool.
Impulse sensor, number of shims	
Conditions: A: No edge outside the tool.	0 pcs
Conditions: B: One edge outside the tool.	1 pc
Conditions: C: Two edges outside the tool.	2 pcs

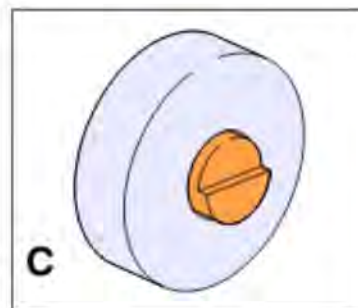
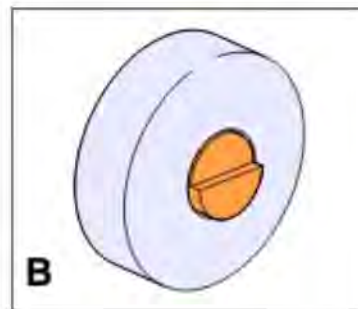
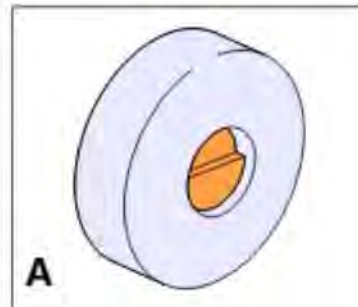
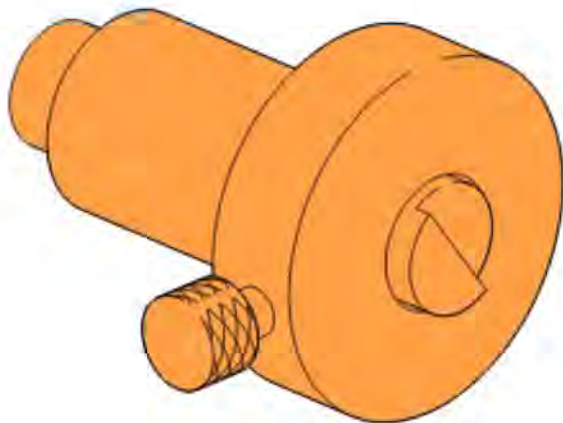

327	Remove the setting tool.
------------	--------------------------

328	Install the shims as needed.
------------	------------------------------

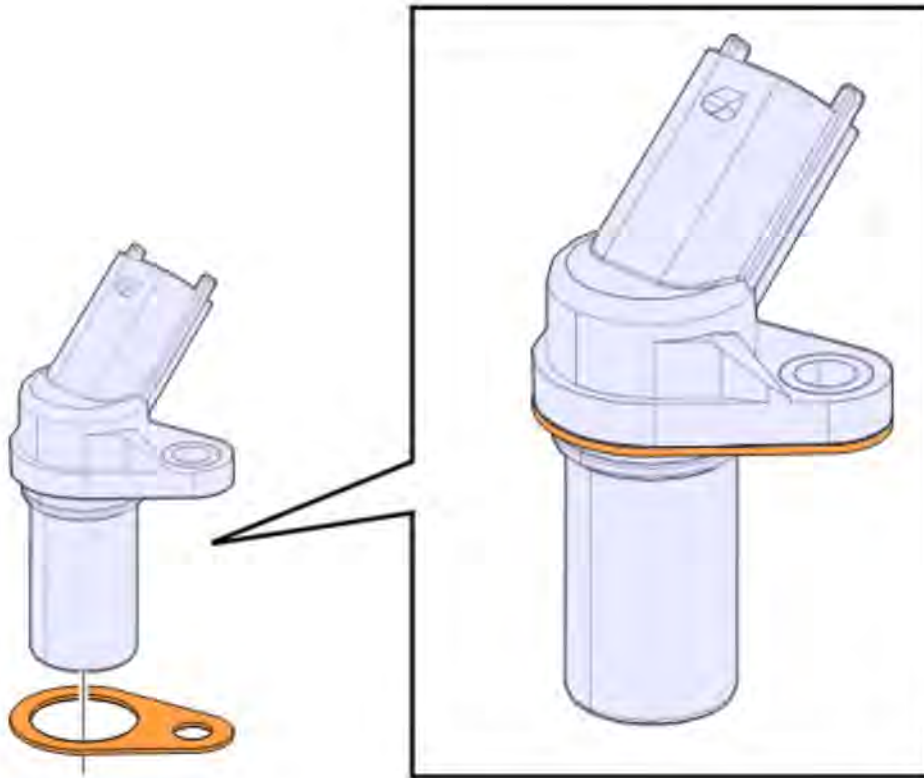

329 Remove the old sealant from the contact surfaces (A).



Note

Ensure that the surfaces are completely clean from sealant.



Note

Ensure that the sealant on the timing gear plate is not damaged (B).

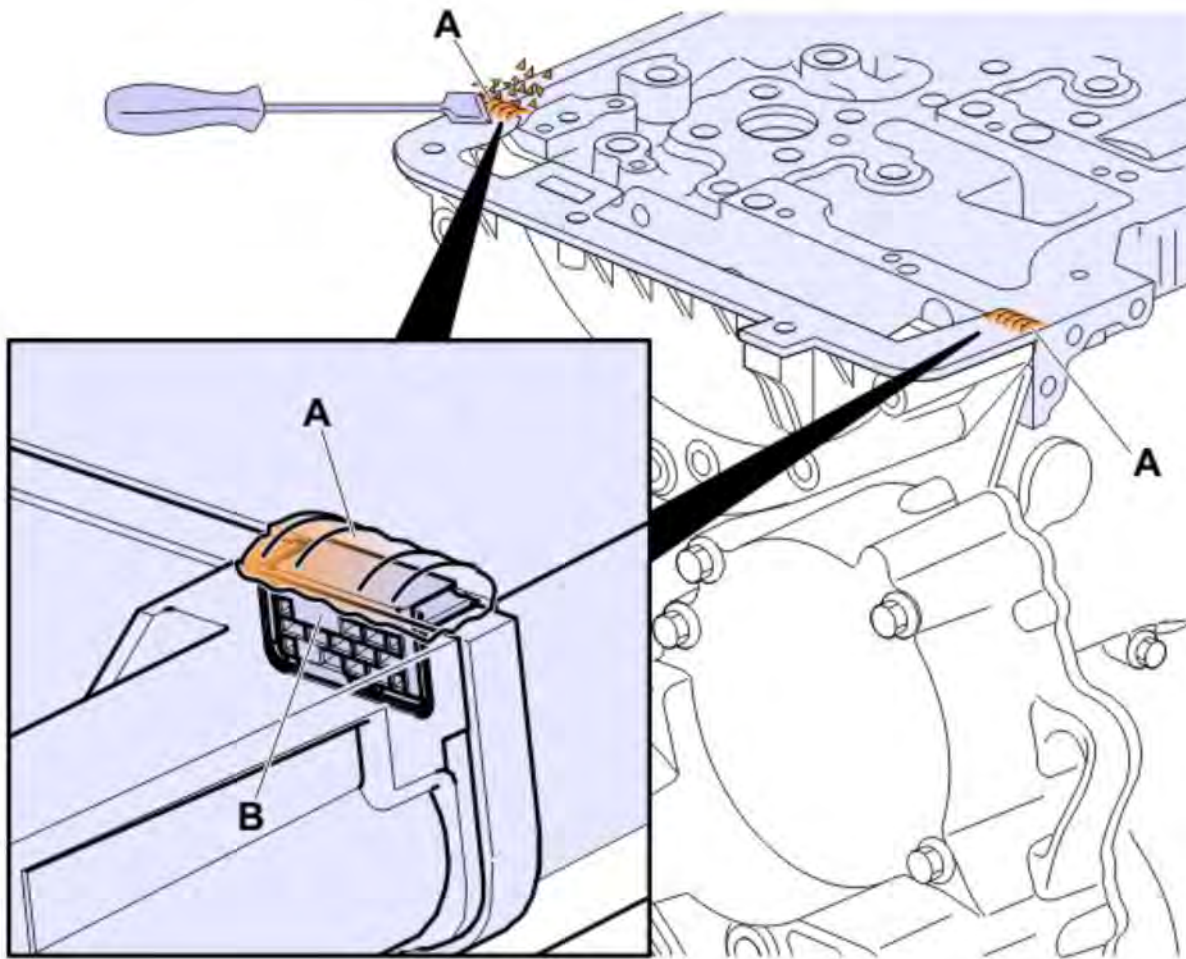

330	Apply sealant.	
Tech data		
Sealant, bead thickness		2 mm (0.08 in)
i	Note Use recommended sealant.	
i	Note Install the valve cover within 20 minutes of applying the sealant.	

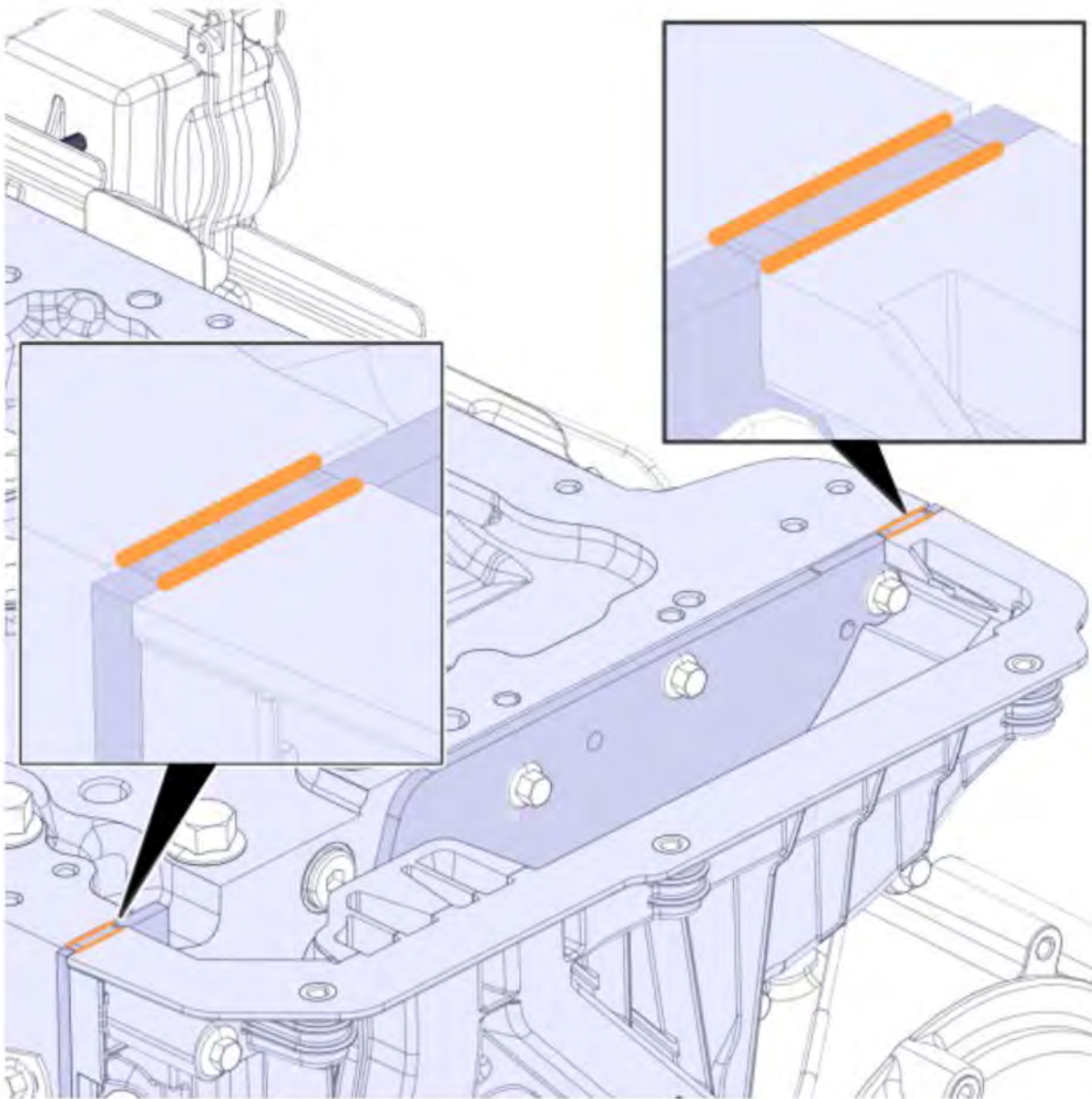

331	Clean the contact surfaces carefully.
------------	---------------------------------------

332	Clean the groove.		
	<table border="1" style="width: 100%;"> <tr> <td style="width: 20px; text-align: center; vertical-align: middle;">i</td> <td>Note Ensure that the surfaces are completely clean of oil and grease.</td> </tr> </table>	i	Note Ensure that the surfaces are completely clean of oil and grease.
i	Note Ensure that the surfaces are completely clean of oil and grease.		

333	Install the gasket.		
	<table border="1" style="width: 100%;"> <tr> <td style="width: 20px; text-align: center; vertical-align: middle;">i</td> <td>Note Use a new part.</td> </tr> </table>	i	Note Use a new part.
i	Note Use a new part.		

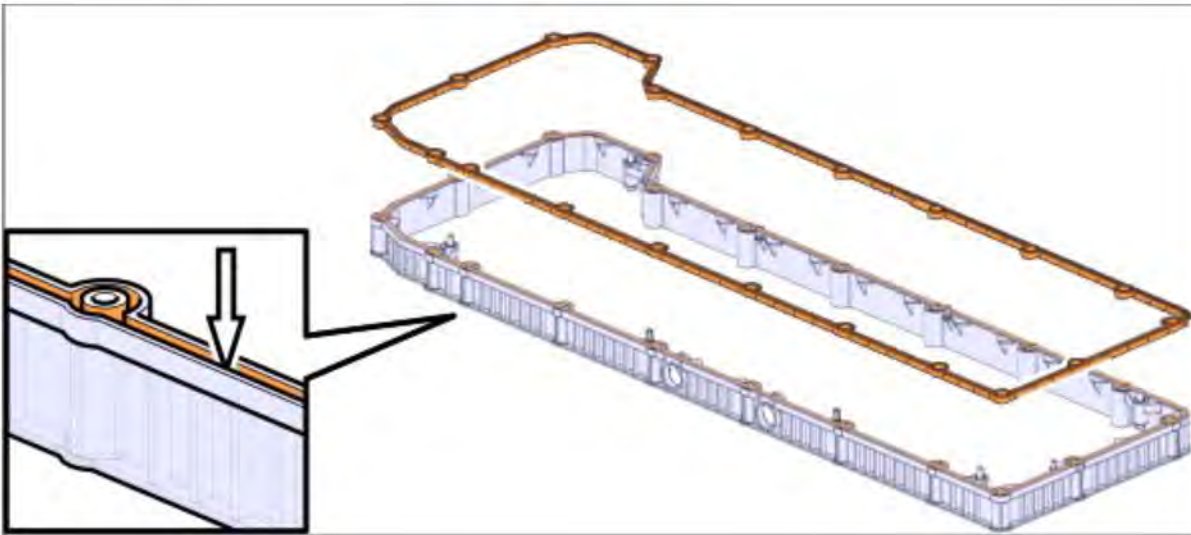

334 Install the frame.

335	Torque tighten the screws.	
	Tightening torque	
	Lower valve cover, screw	Tightening sequence: 1-4 $24 \pm 4 \text{ Nm}$ $(18 \pm 3 \text{ lb}_f\text{-ft})$

336 Connect the connectors.

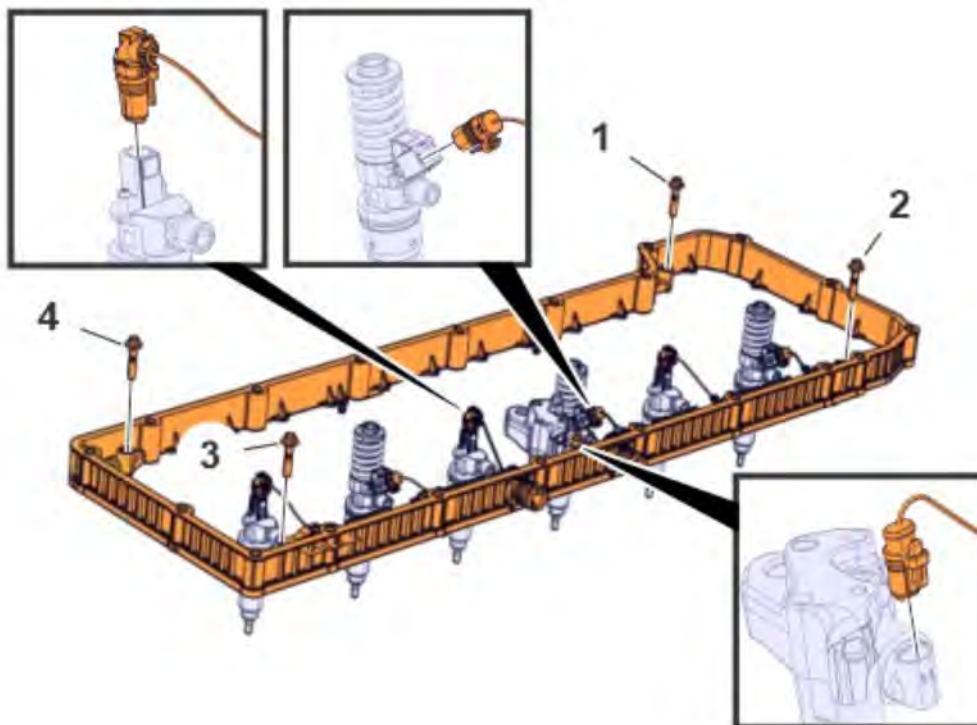

337 Connect the connectors.

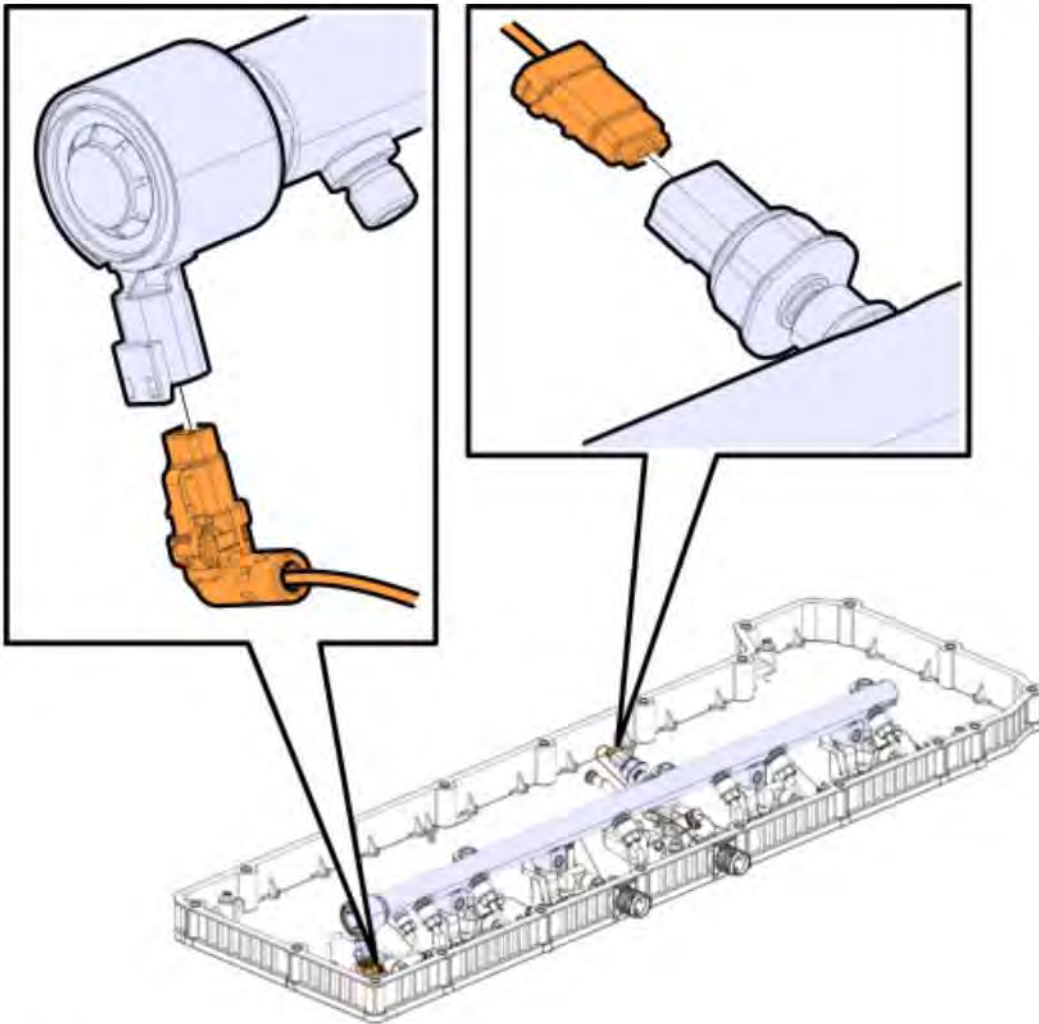

338 Connect the connectors.

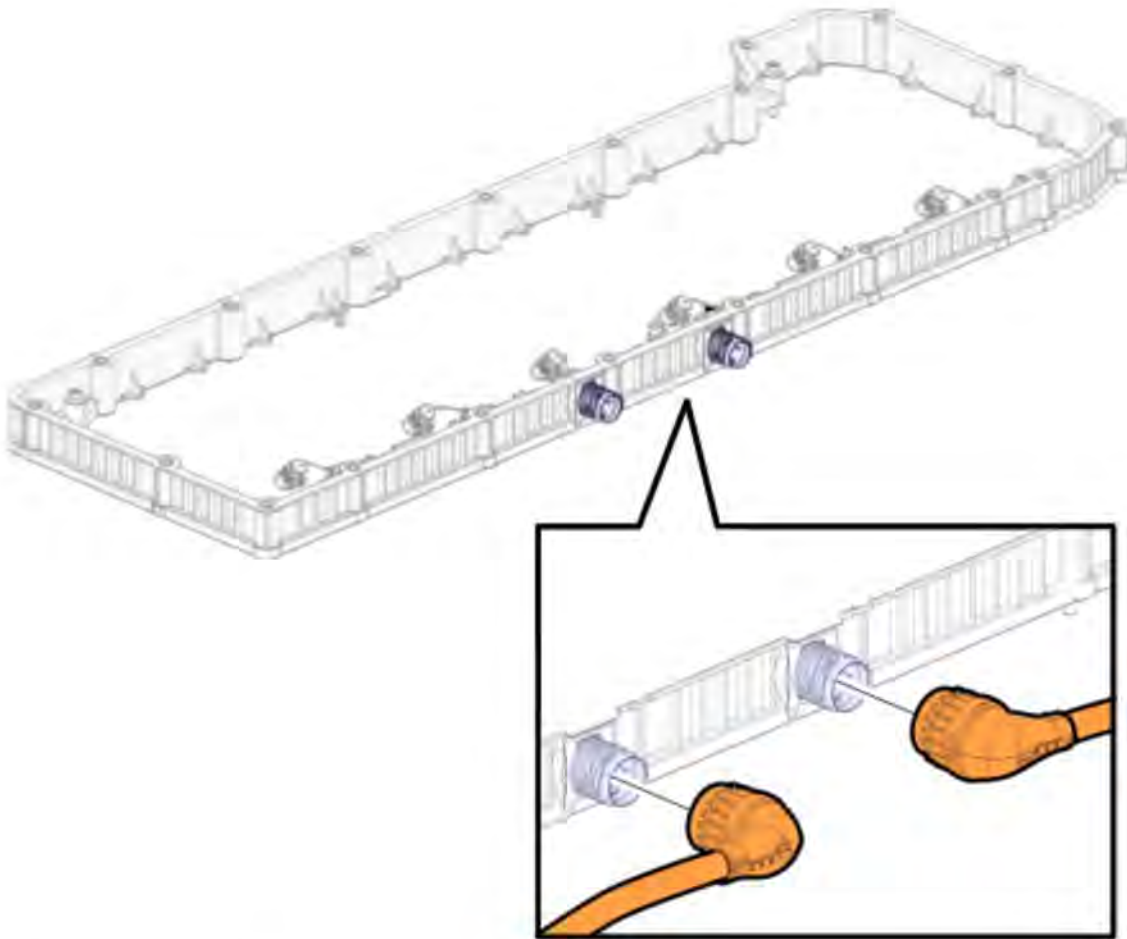

339 Position the screws.



Note

Inspect the gasket, replace as needed.



Service hint

Temporarily securing the screws at the rear of the cover in the uppermost position will aid in installation

340 Install the valve cover.

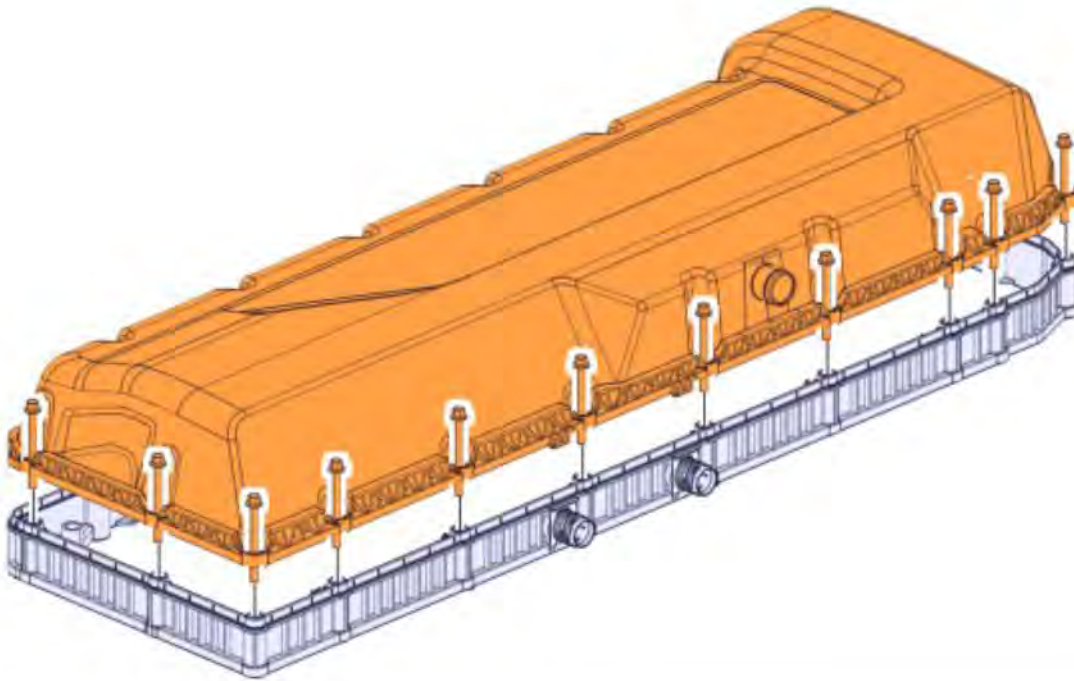

341 Tighten the screws to torque.

Tightening torque	
Valve cover, screw	Tightening sequence: 1-20
	24 ±4 Nm (18 ±3 lb _f -ft)

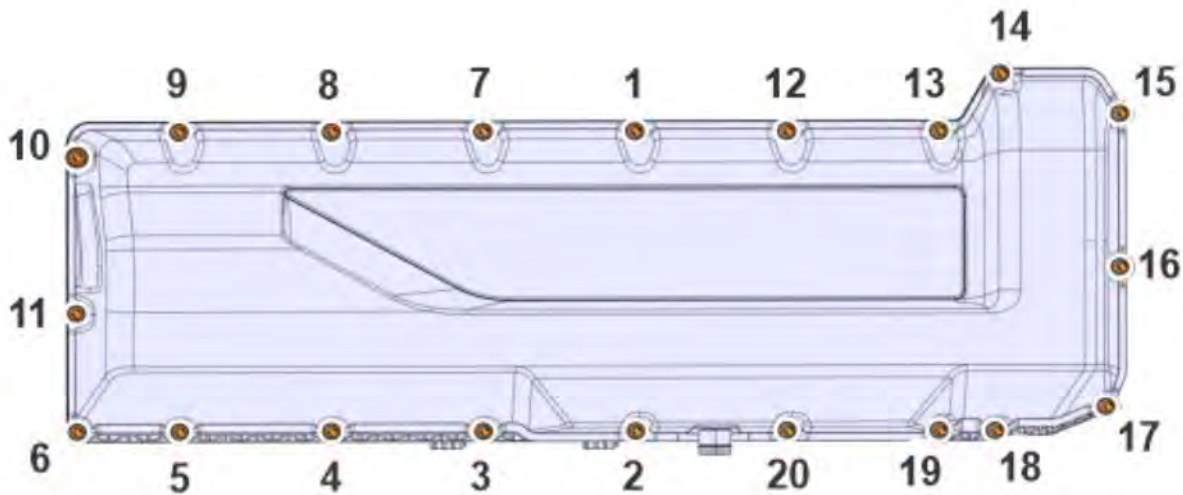

Tightening torque	
Valve cover, screw	Tightening sequence: 1-20
	24 ±4 Nm (18 ±3 lb _f -ft)

Copyright to this documentation belongs to the Volvo Group. No reproduction, copying, change, amendment or other similar disposal is entitled without prior written consent by the Volvo Group

The information contained herein is current at the time of its original distribution, but is subject to change. The reader is advised that printed copies are uncontrolled.

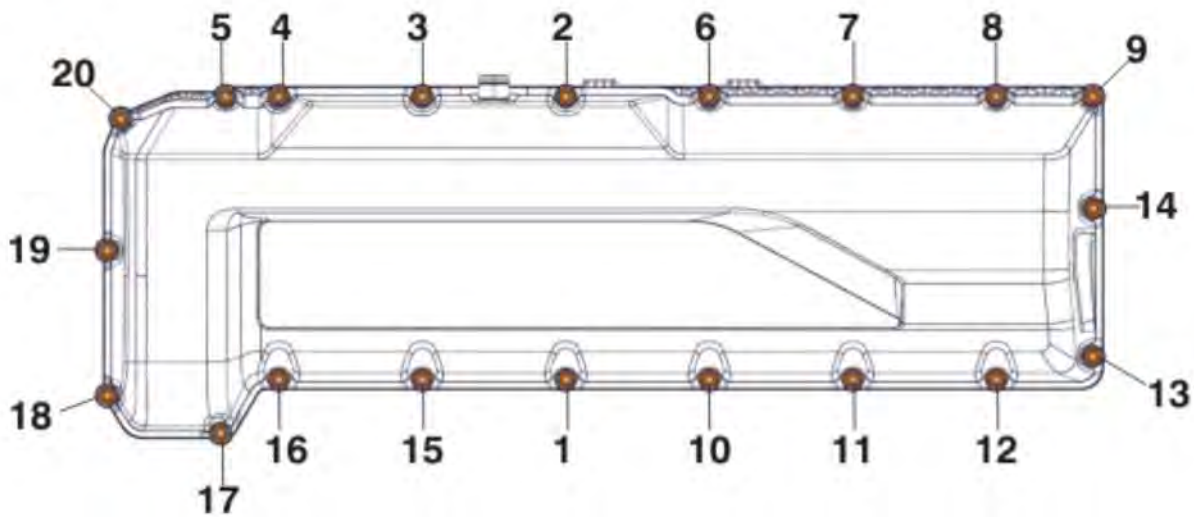

342 Install the pipe.



Note
If not previously installed.



Note
Inspect the internal sealing ring.

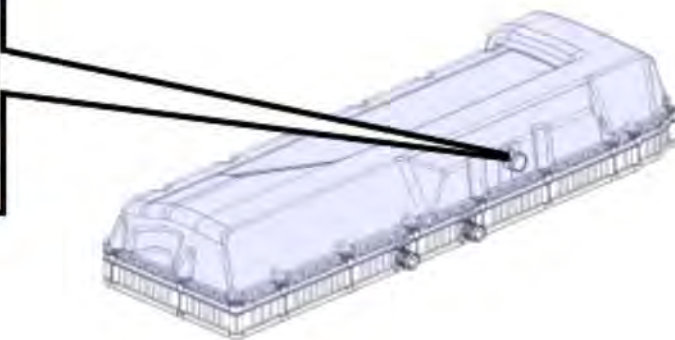
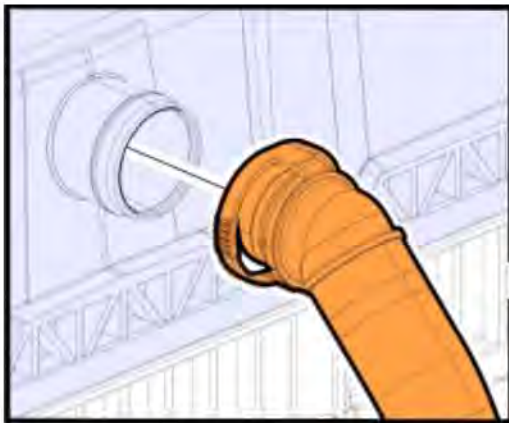

343 Install the pipe.

344 Install the screw.

345 Torque-tighten the screw.

Tightening torque

Screw	M8
	24 ±4 Nm
	(18 ±3 lb _f ·ft)

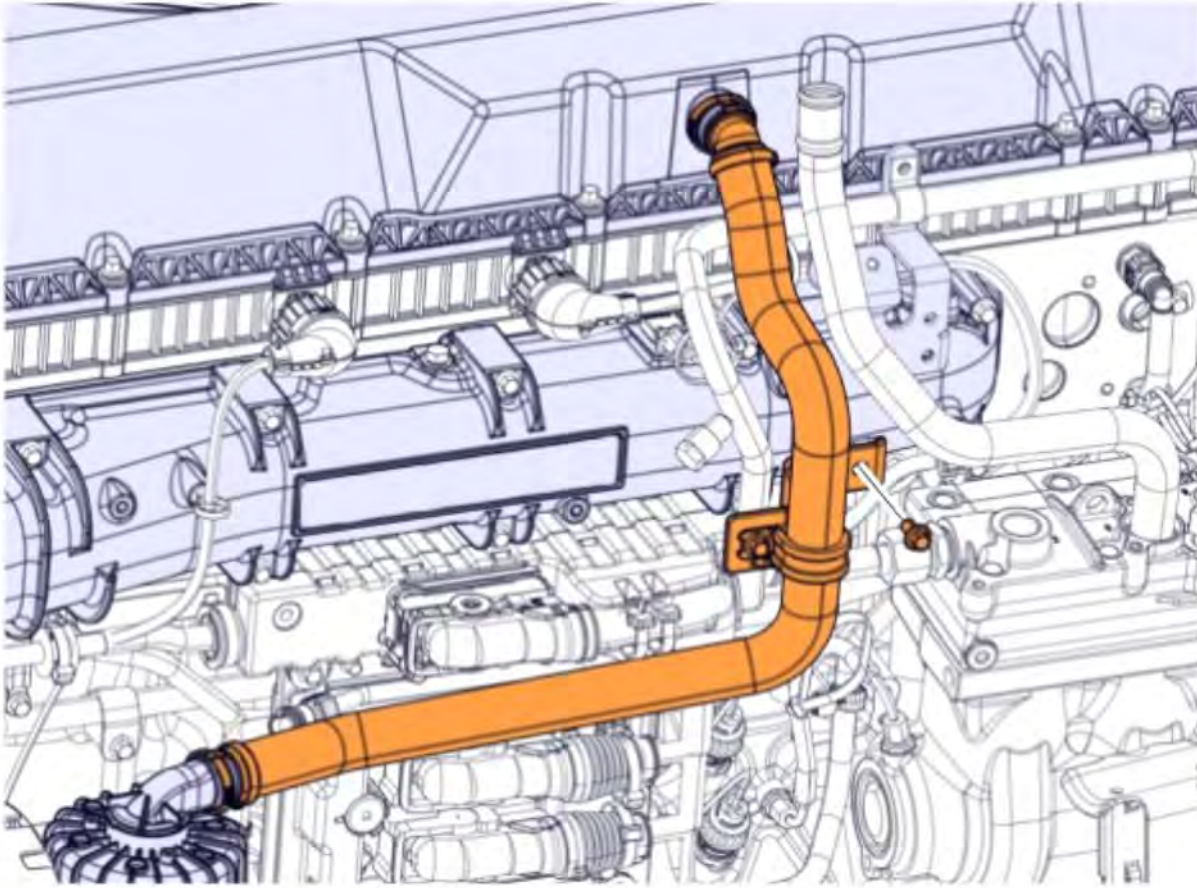

346 Install the pipe.



Note

Check the sealing ring and hose for damage; replace as needed.

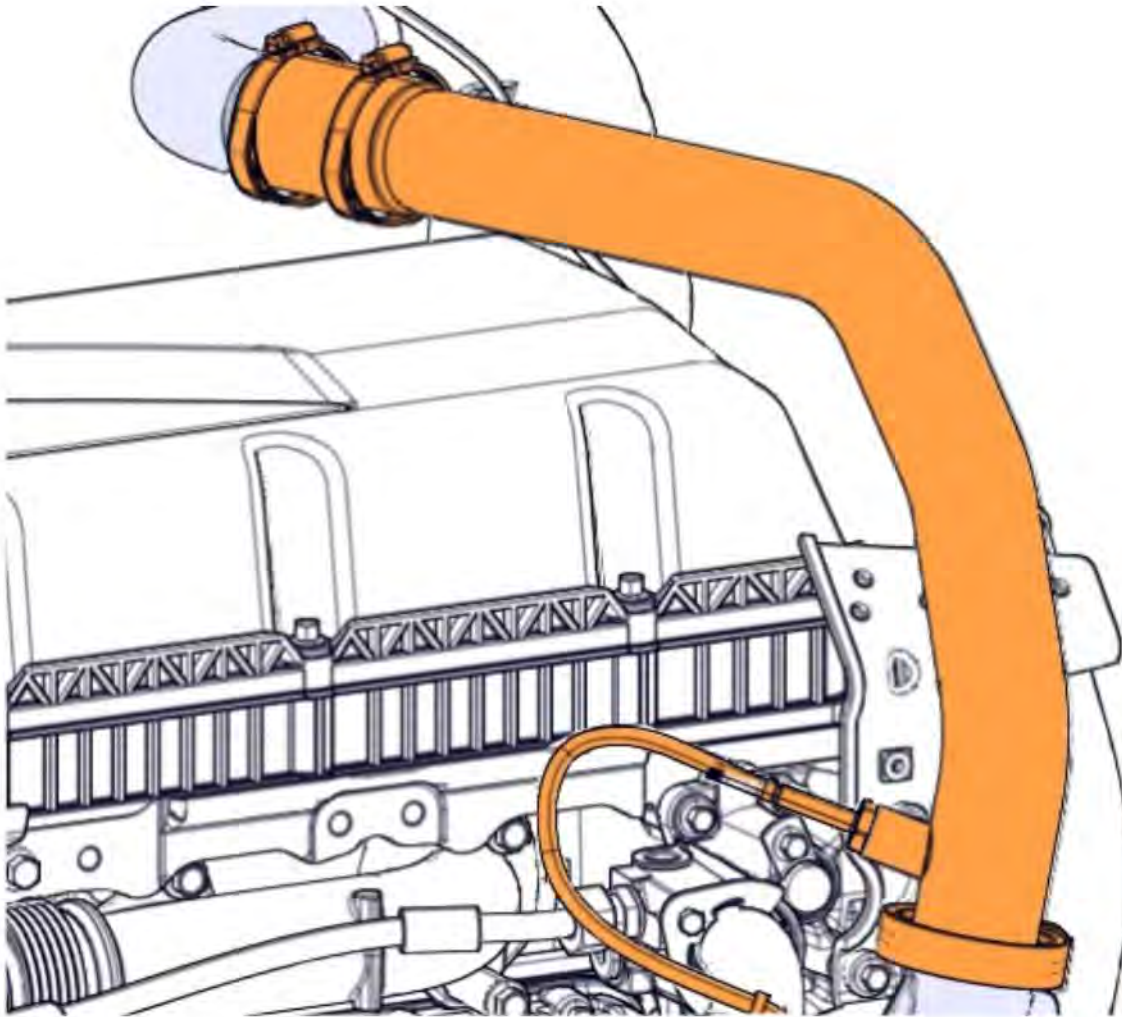

347 Position the clamps.

i	Note As noted.
----------	--------------------------

348	Tighten the clamps to torque.	
Tightening torque		
	V band clamp screw	10.2 ±1 Nm (90 ±9 lb _f ·in)
Tightening torque		
	Hose clamp	11.9 ±2 Nm (105 ±18 lb _f ·in)

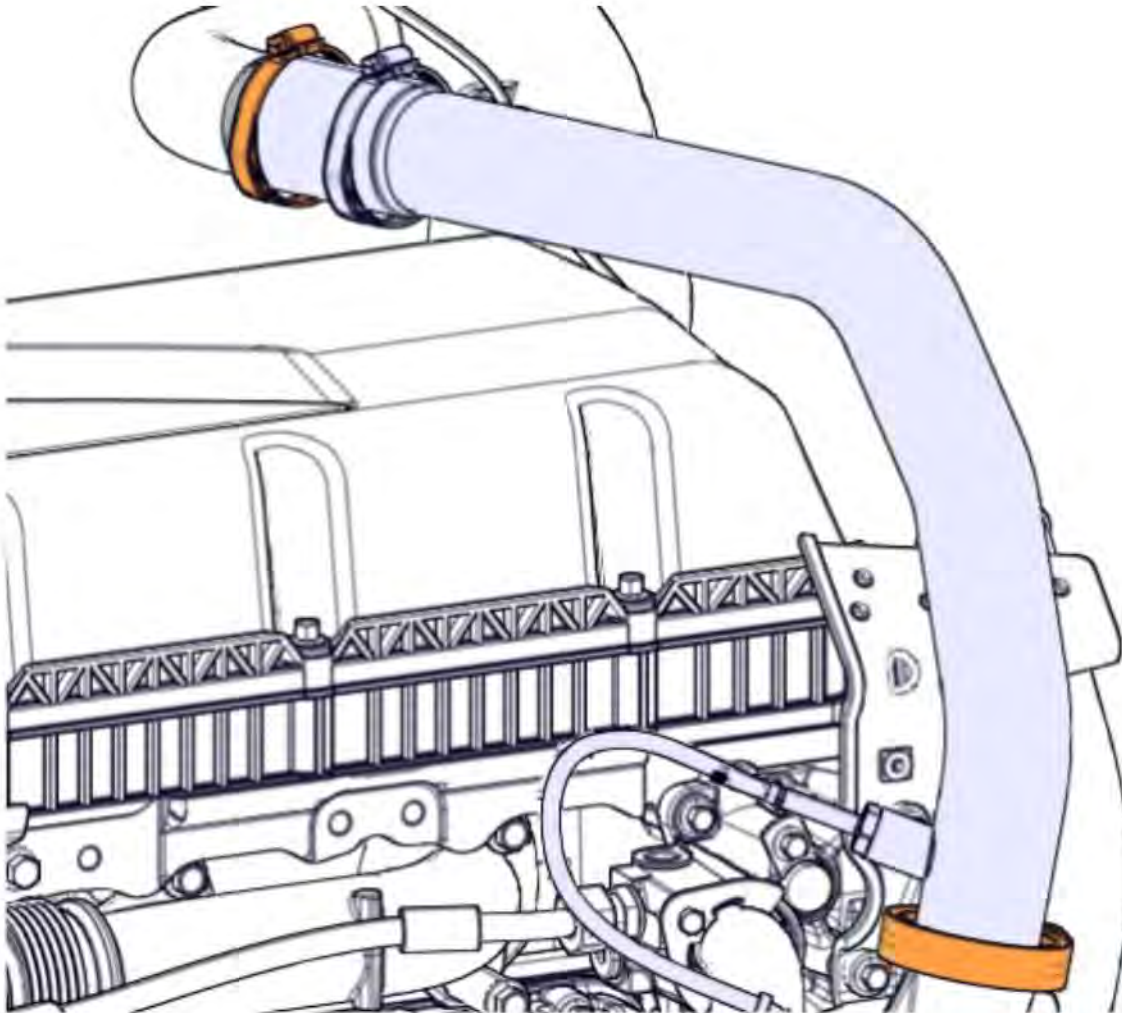

349 Install the clamp.

350 Torque tighten the screws.

Tightening torque

Screw	M8
	24 ±4 Nm
	(18 ±3 lb _f .ft)

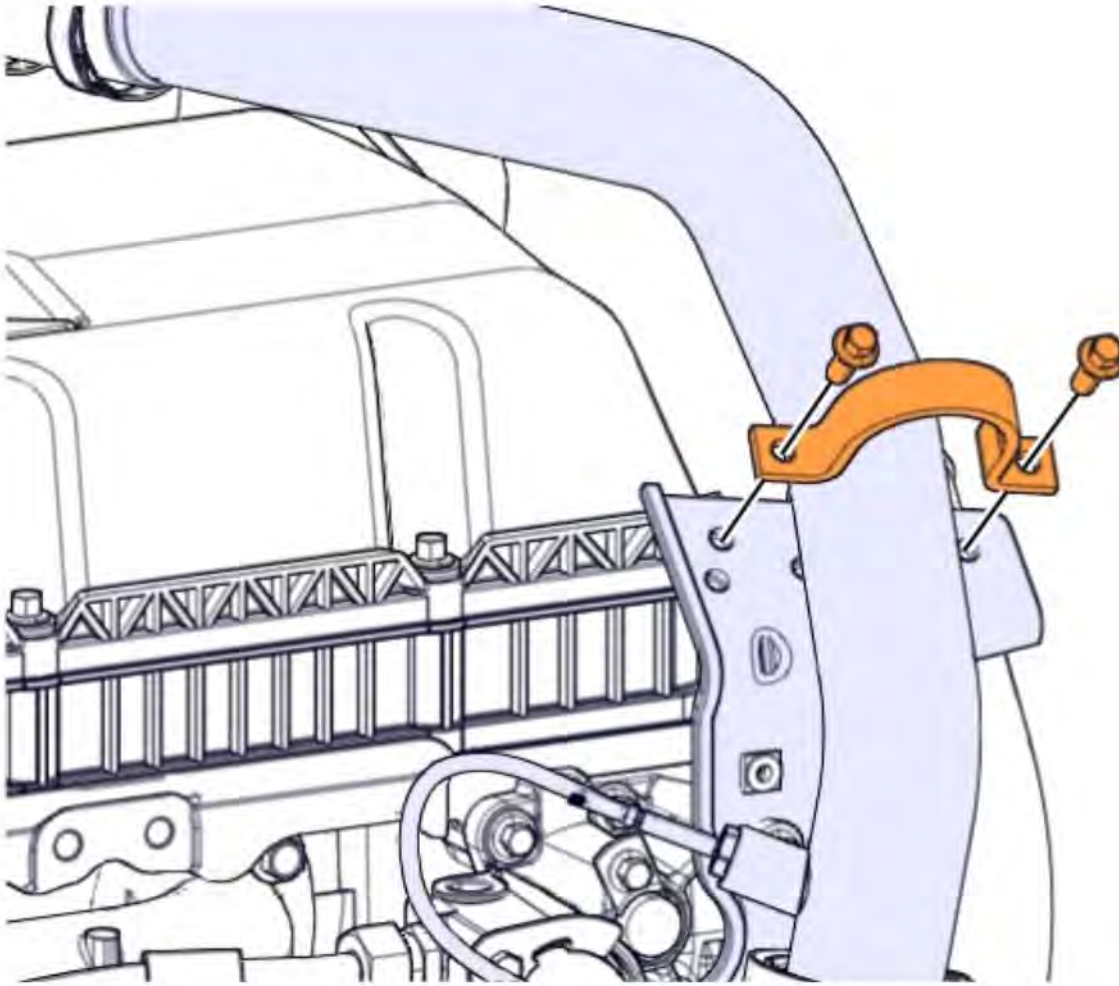

351	Connect the connector.
-----	------------------------

352	Install the cable tie.
-----	------------------------

**Note**

Use a new part.

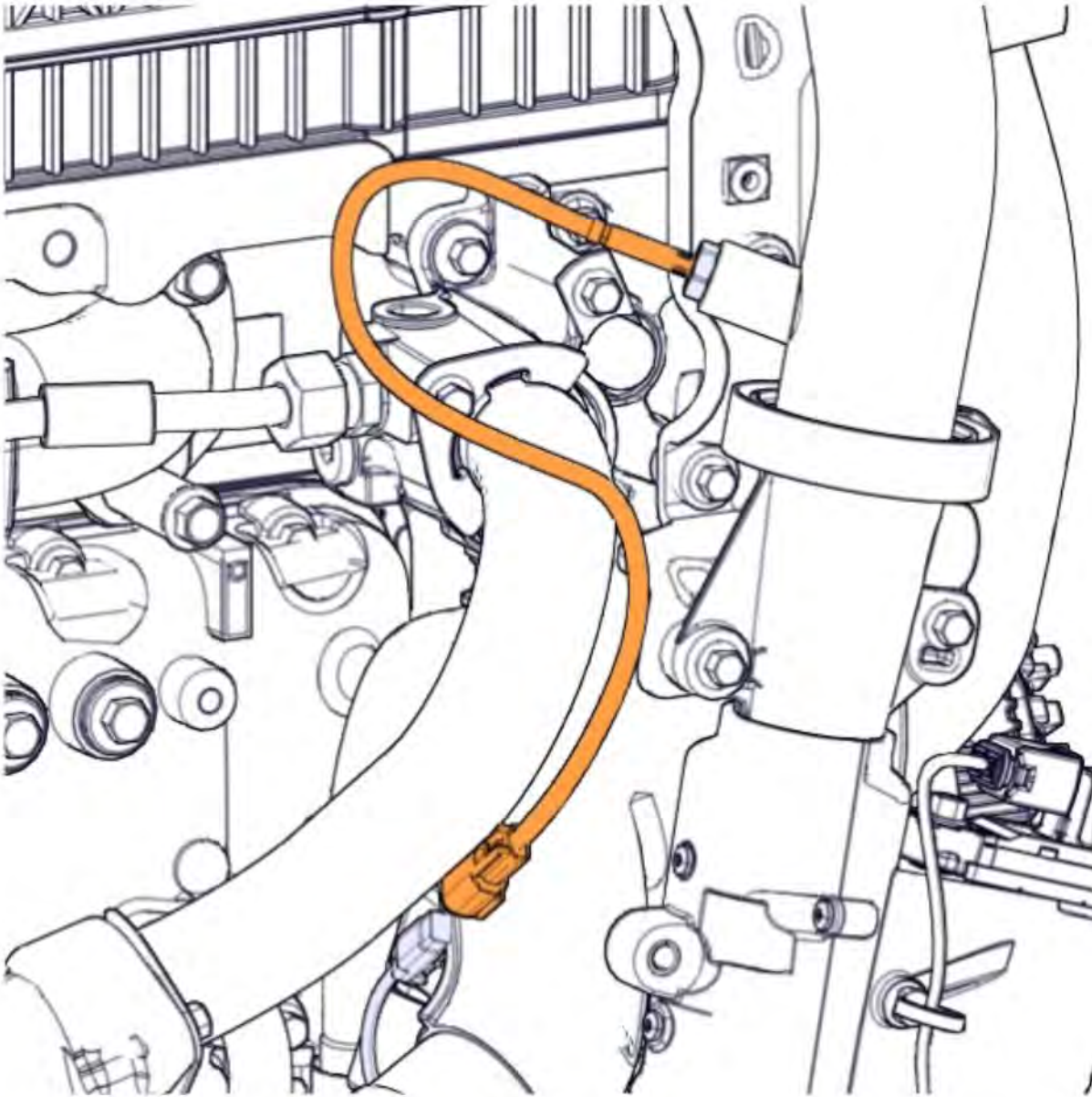

353	Install the bracket.
-----	----------------------

354	Install the screw.
-----	--------------------

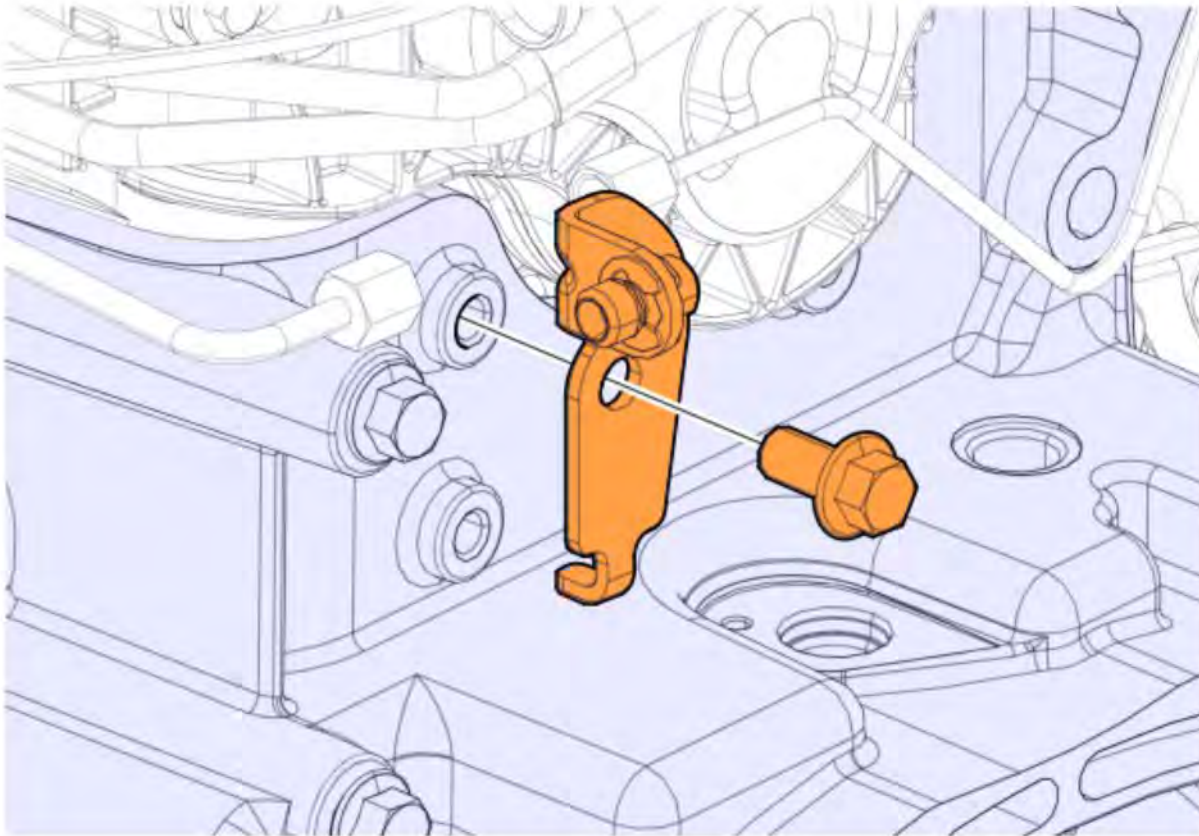

355	Install the nut.
------------	------------------

356	Torque tighten the nut.
------------	-------------------------

Tightening torque	
Fitting	#4
	15 ±1 Nm (11 ±1 lb _f .ft)

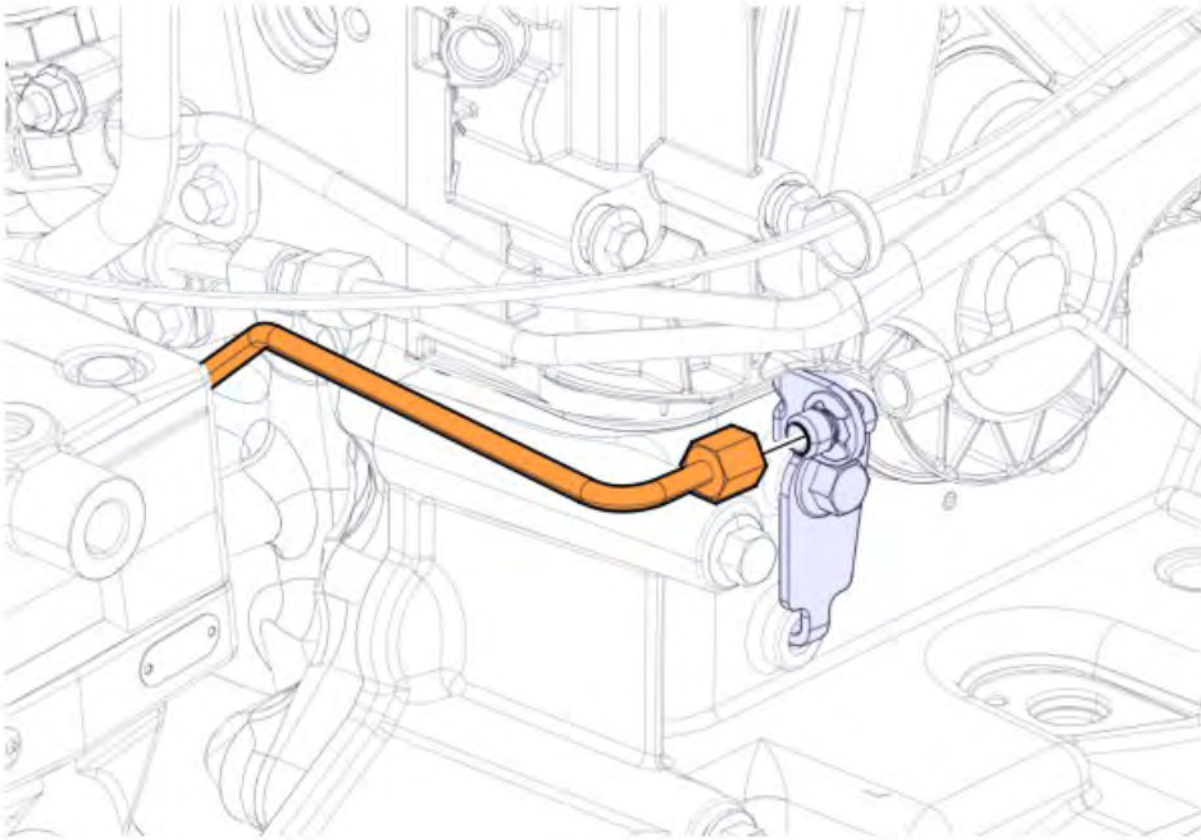

357	Install the clamps.
------------	---------------------

358	Install the screws.
------------	---------------------



359	Position the pipe.
------------	--------------------

360	Install the screw.
------------	--------------------

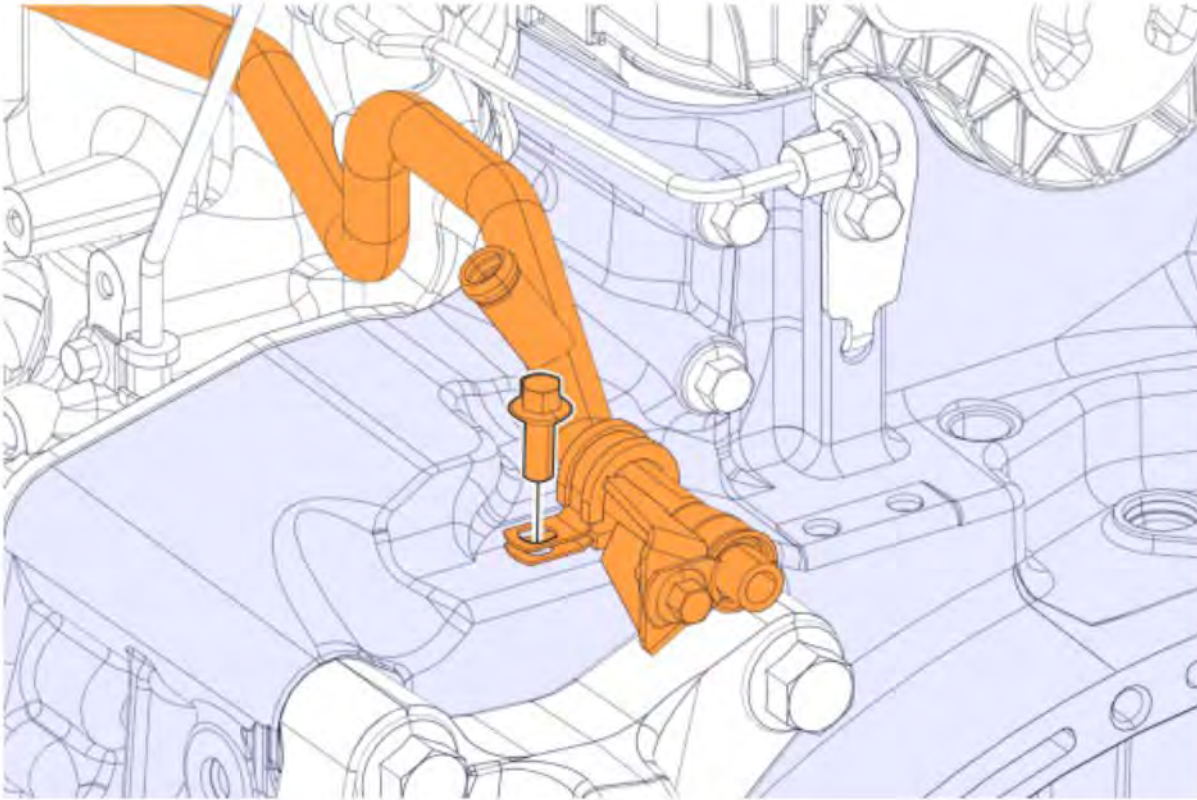

361 Lubricate the O-ring.



Note

Use a new part.



Note

Use recommended oil.

362 Install the O-ring.



	CAUTION
---	----------------

Risk of serious injury.
 Heavy component.

▶ Exercise caution when moving the component. Use appropriate tools.

363 Install the compressor.

	Note Take care not to damage surrounding components.
---	--

364 Install the nuts.

365 Torque tighten the nuts diagonally.

Tightening torque	
Compressor, mounting nut	85 ±15 Nm (63 ±11 lb _f -ft)

366 Repeat the operation a second time.

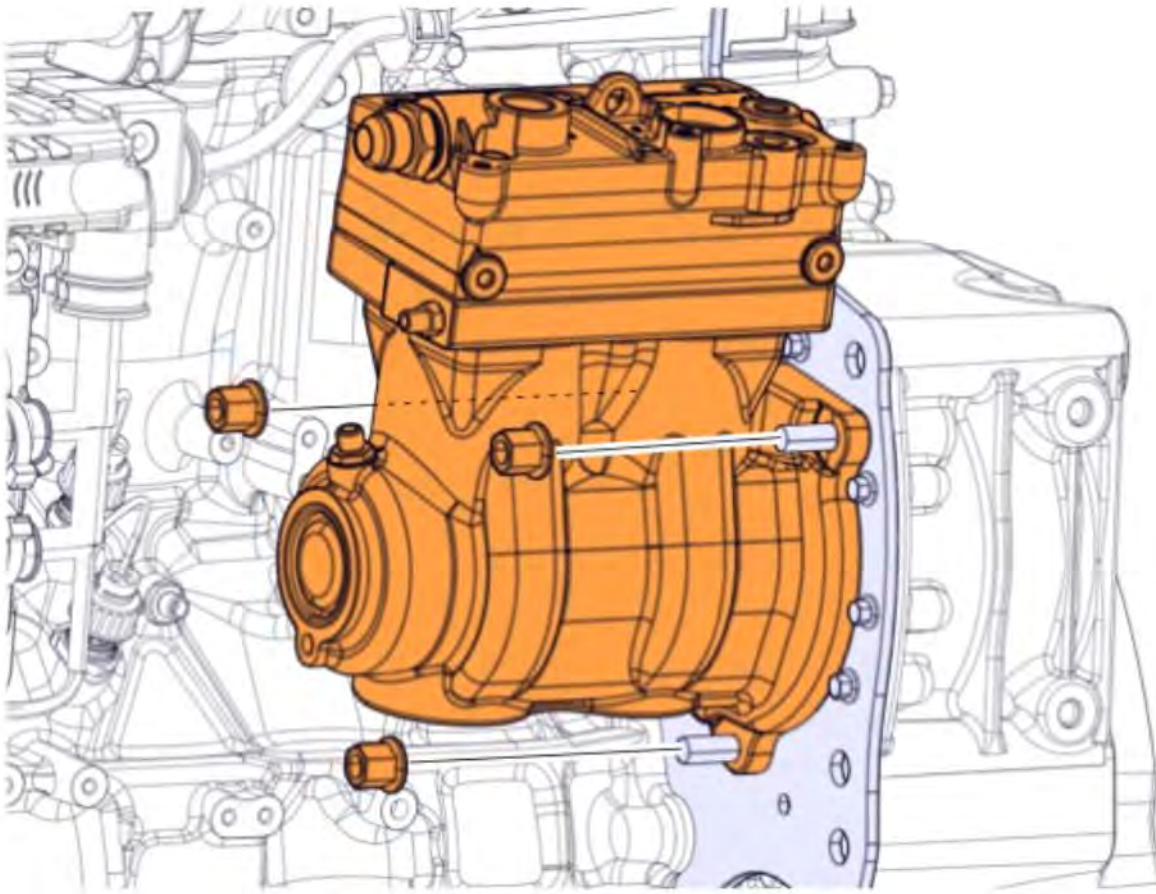

367	Connect the hoses.
------------	--------------------

368	Torque tighten the clamps.
------------	----------------------------

Tightening torque	
--------------------------	--

Compressor, coolant hose, clamp	$3 \pm 0.5 \text{ Nm}$ $(2 \pm 0.4 \text{ lb}_f\text{-ft})$
---------------------------------	--

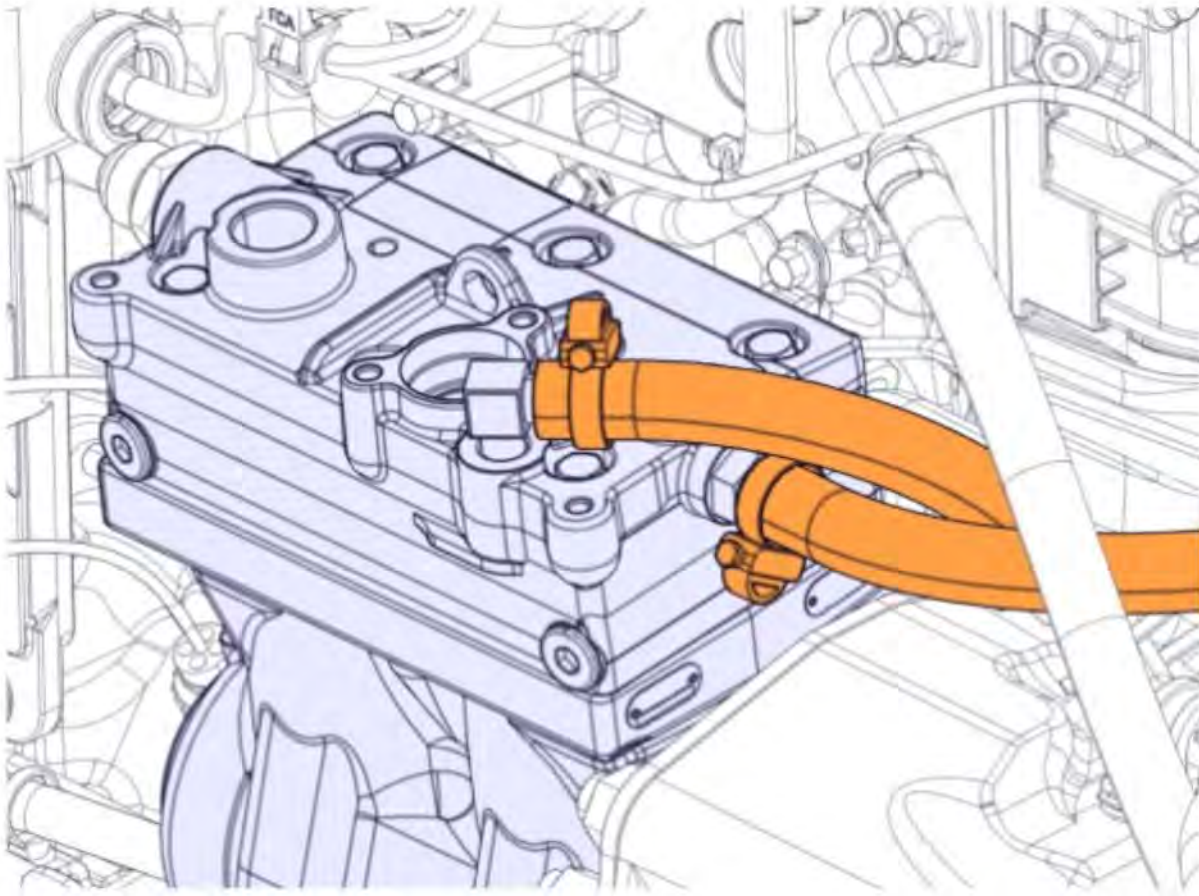

369	Lubricate the sealing ring.		
	<table border="1" style="width: 100%;"> <tr> <td style="width: 20px; text-align: center;">i</td> <td>Note Use recommended oil.</td> </tr> </table>	i	Note Use recommended oil.
i	Note Use recommended oil.		

370	Install the sealing ring.		
	<table border="1" style="width: 100%;"> <tr> <td style="width: 20px; text-align: center;">i</td> <td>Note Use a new part.</td> </tr> </table>	i	Note Use a new part.
i	Note Use a new part.		

371	Install the pipe along with the lock braces.
------------	--

372	Install the screws.
------------	---------------------

373	Torque tighten the screws.						
	Tightening torque						
	<table border="1" style="width: 100%;"> <tr> <td style="width: 50%;">Lock brace, screw</td> <td>M8</td> </tr> <tr> <td></td> <td>24 ±4 Nm</td> </tr> <tr> <td></td> <td>(18 ±3 lb_f.ft)</td> </tr> </table>	Lock brace, screw	M8		24 ±4 Nm		(18 ±3 lb _f .ft)
Lock brace, screw	M8						
	24 ±4 Nm						
	(18 ±3 lb _f .ft)						

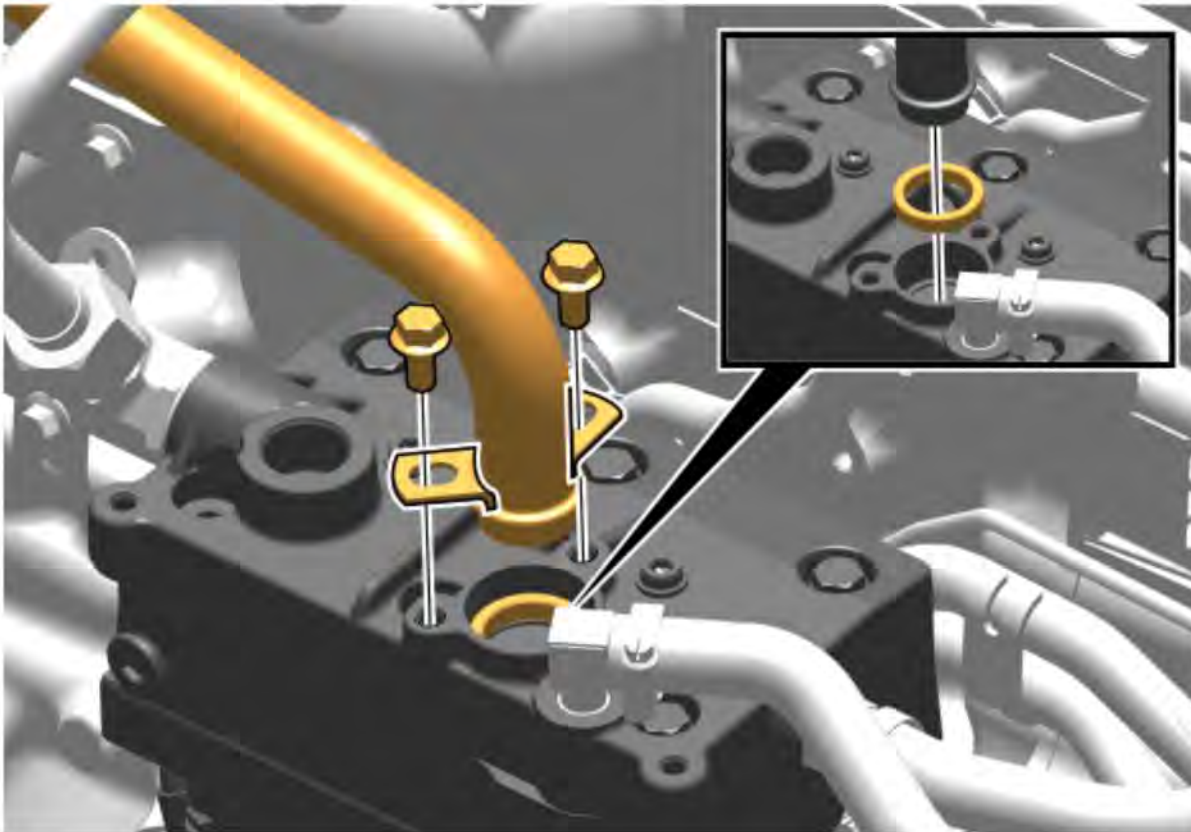

374	Install the pipe.
------------	-------------------

375	Torque tighten the nut.	
	Tightening torque	
	Compressor, air outlet, nut	130 ±20 Nm (96 ±15 lb _f -ft)

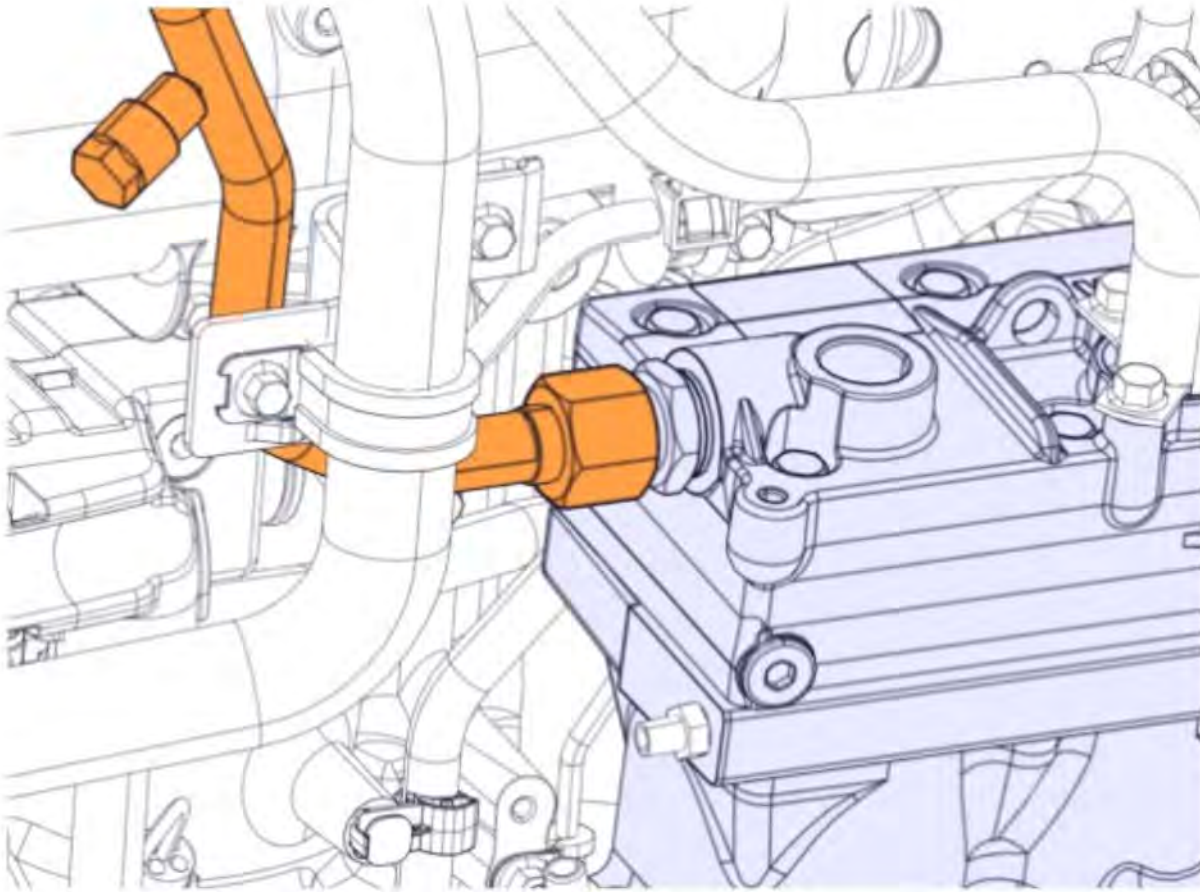

376	Install the oil hose.
------------	-----------------------

377	Torque tighten the fitting nuts.
------------	----------------------------------

Tightening torque	
--------------------------	--

Compressor, oil hose, fitting	$15 \pm 3 \text{ Nm}$ $(11 \pm 2 \text{ lb}_f\text{-ft})$
-------------------------------	--

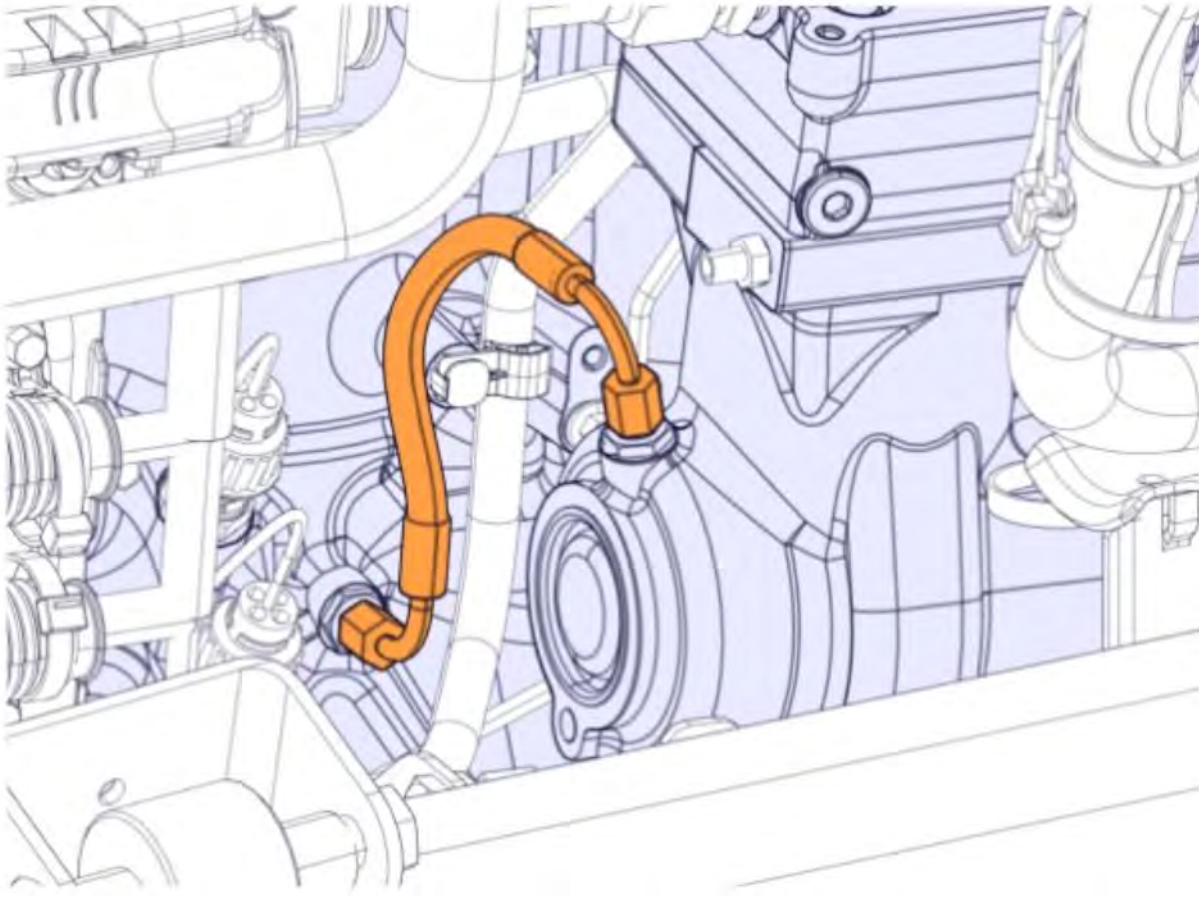

378 Connect the air line.

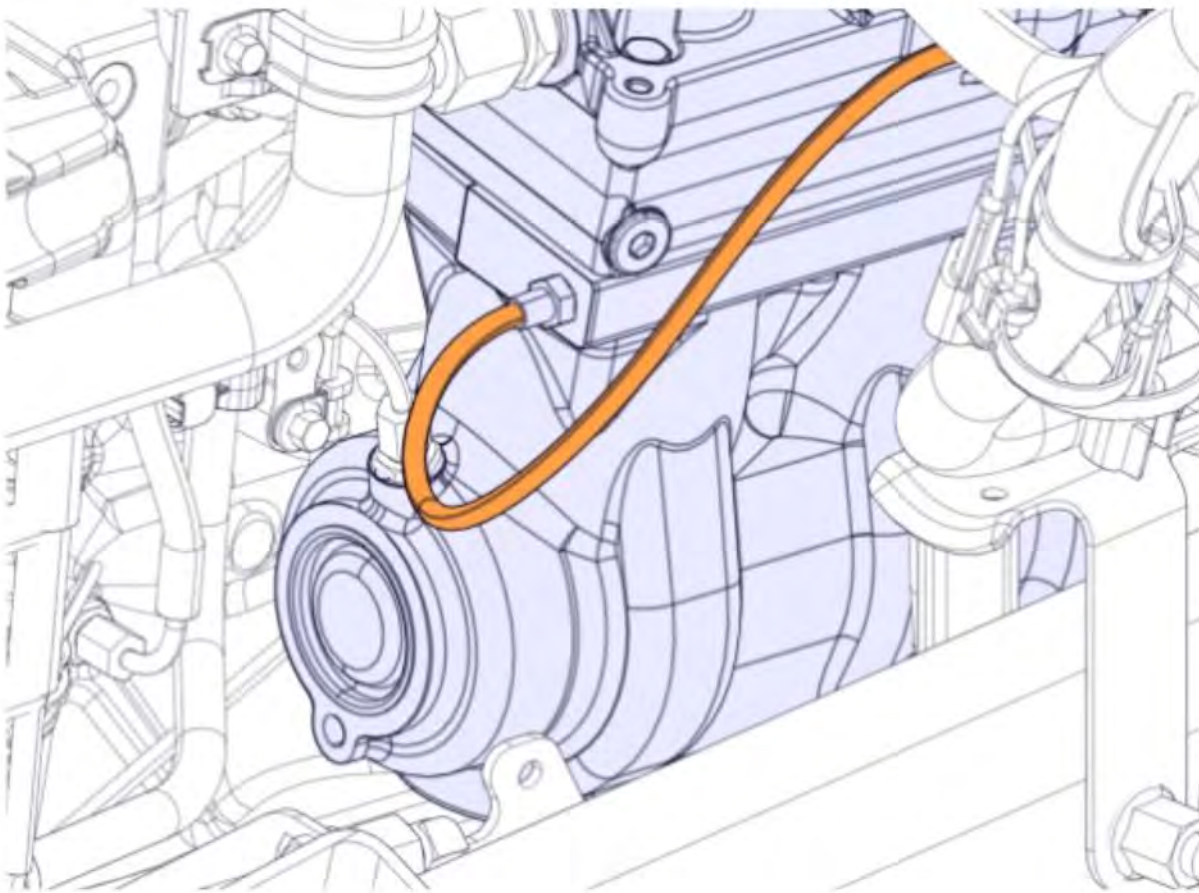

379 Connect the connector.

380 Install the cable ties.

i **Note**
Use new parts.

i **Note**
As noted.

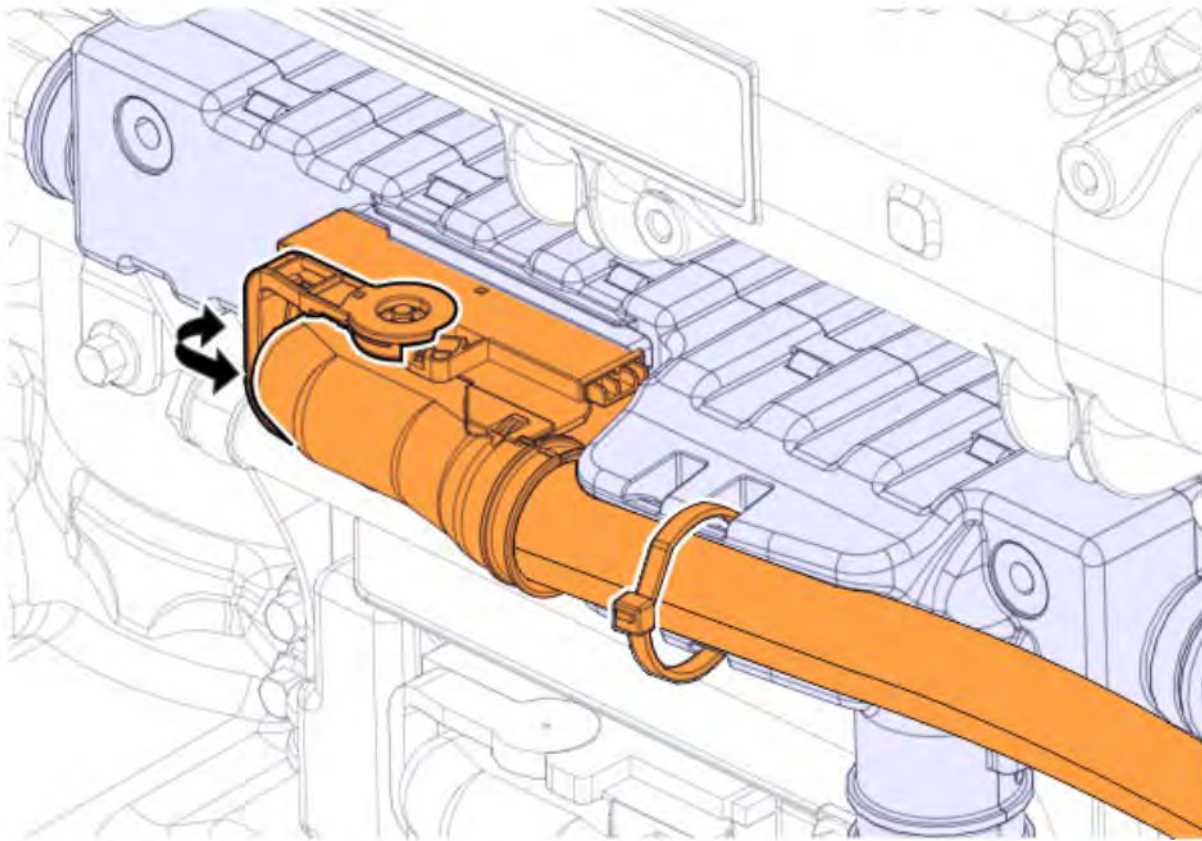

381 Lubricate the seal.

382 Install the seal.

i **Note**
Use a new part

i **Note**
Use recommended oil.

383 Install the pump.

384 Install the screws.

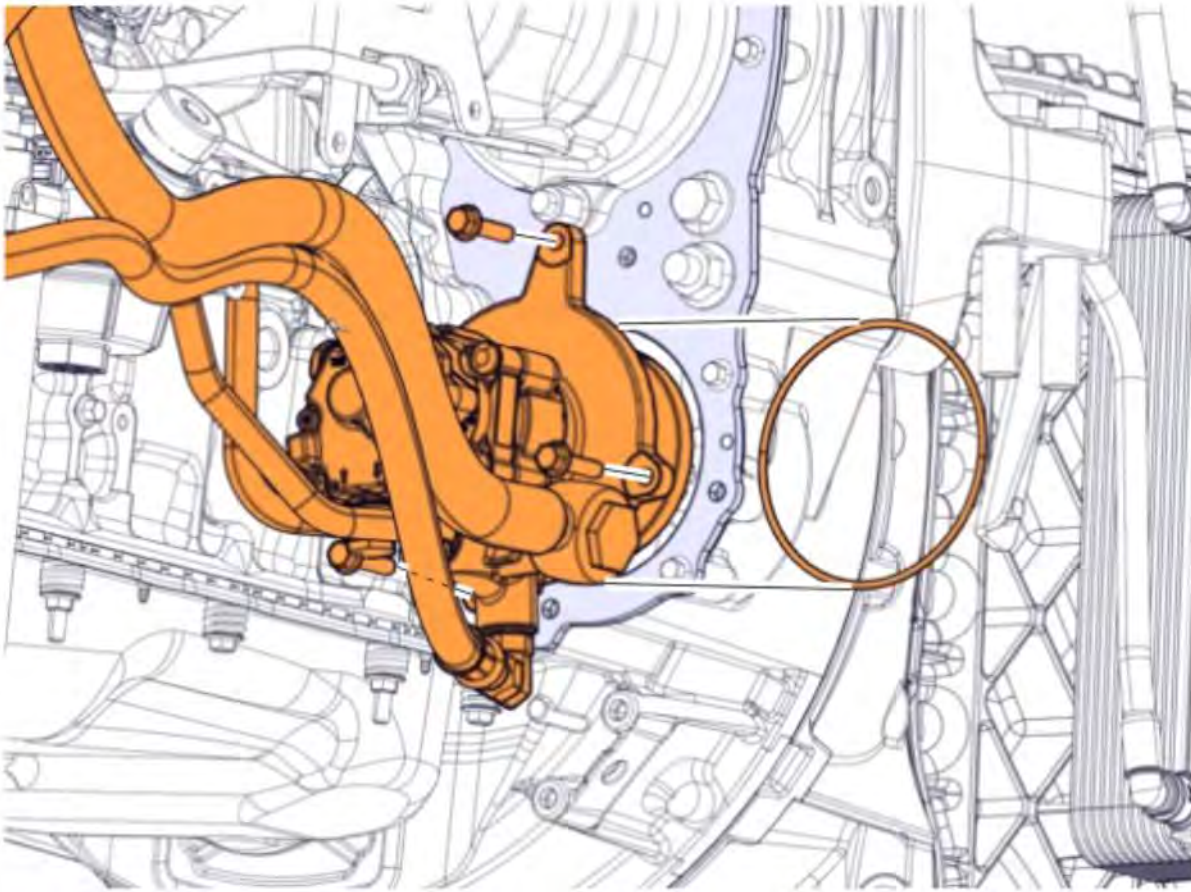

385	Torque tighten the screws.	
	Tightening torque	
	Screw	M8
		24 ±4 Nm (18 ±3 lb _f .ft)

386	Install the seal.	
	i	Note Use a new part.

387	Install the pipe.
------------	-------------------

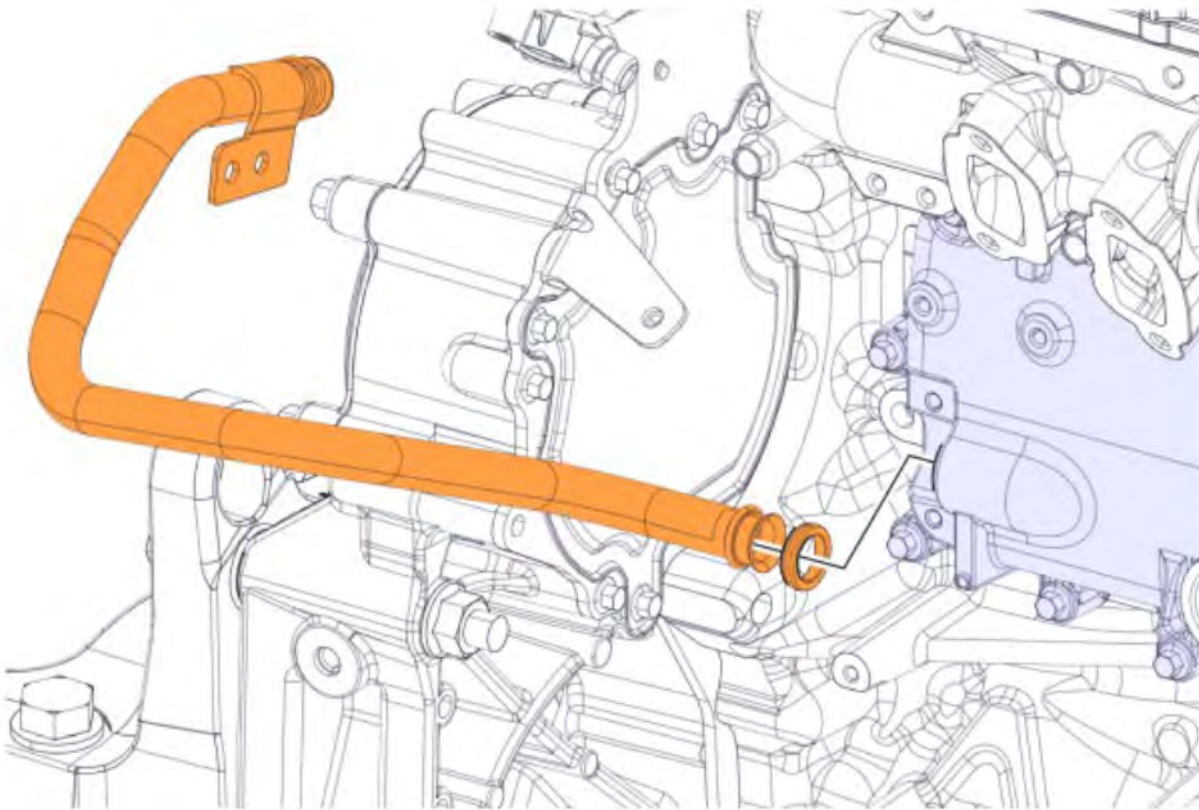

388	Install the clamp.
------------	--------------------

389	Install the screws.
------------	---------------------

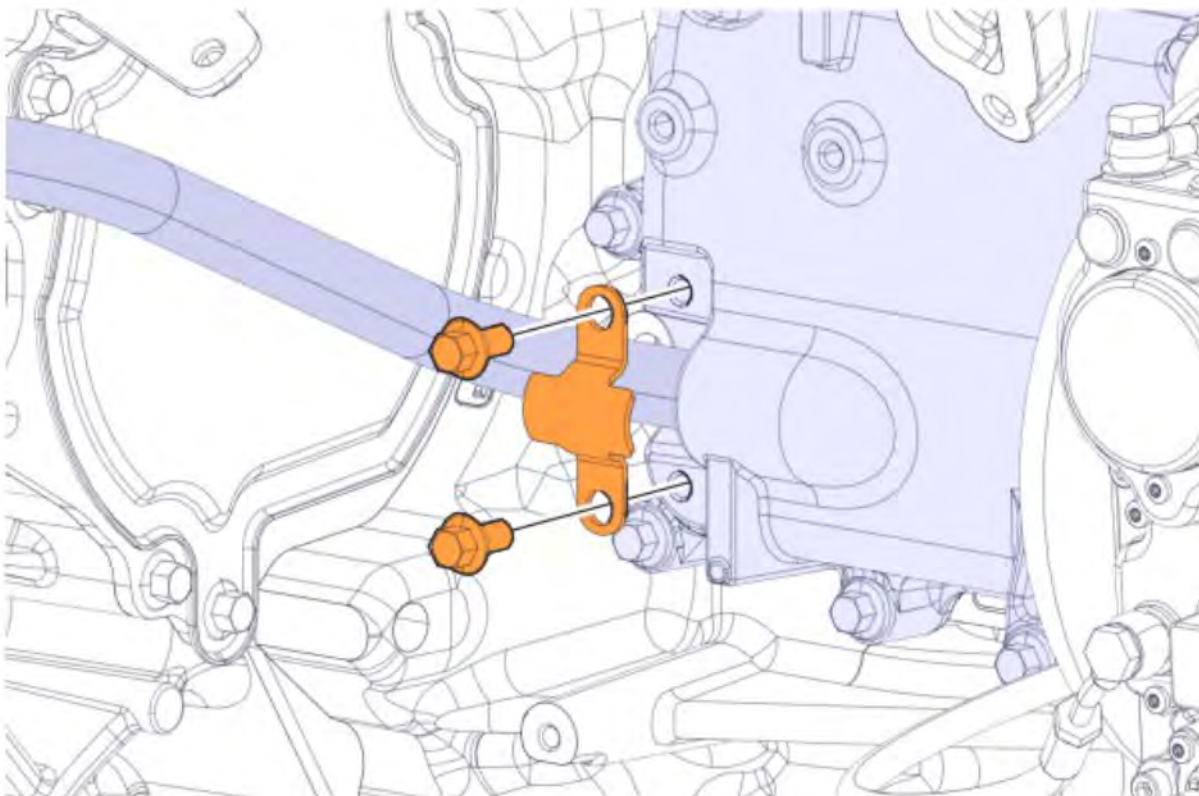

390	Install the screw.
------------	--------------------

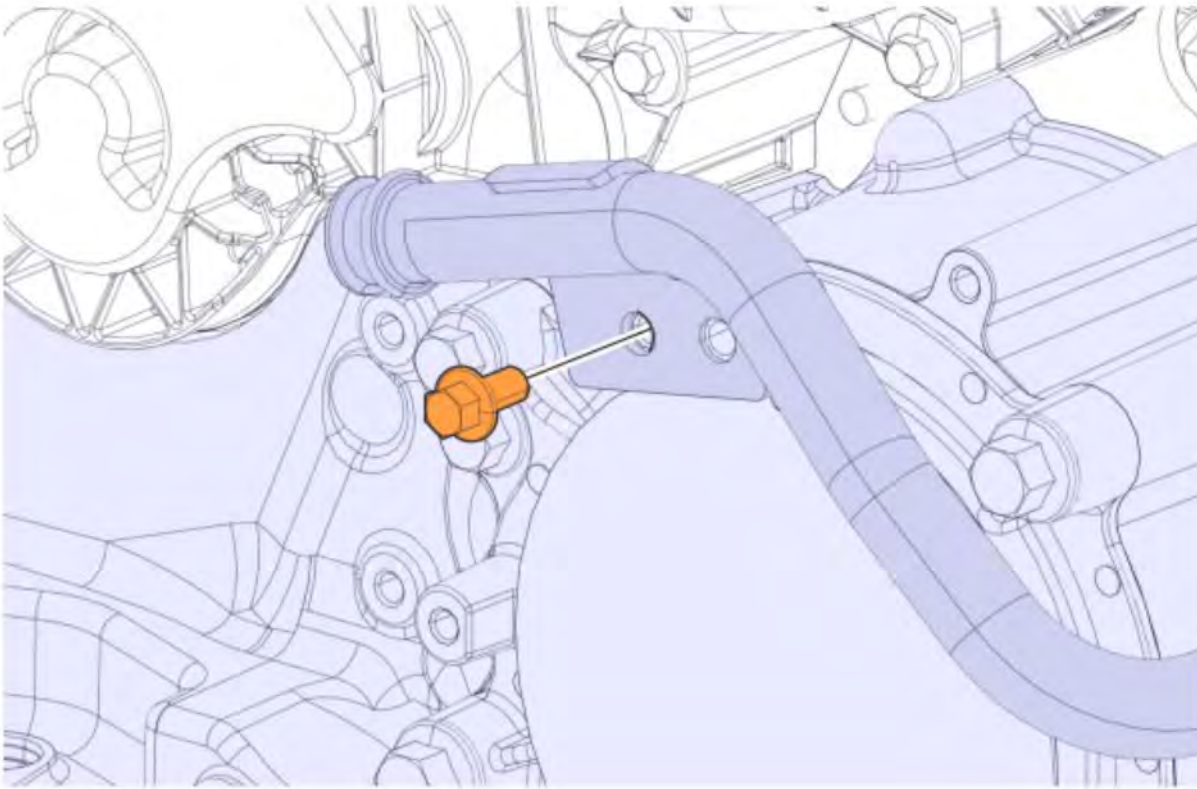

391 Position the assembly.

392 Install the screws.

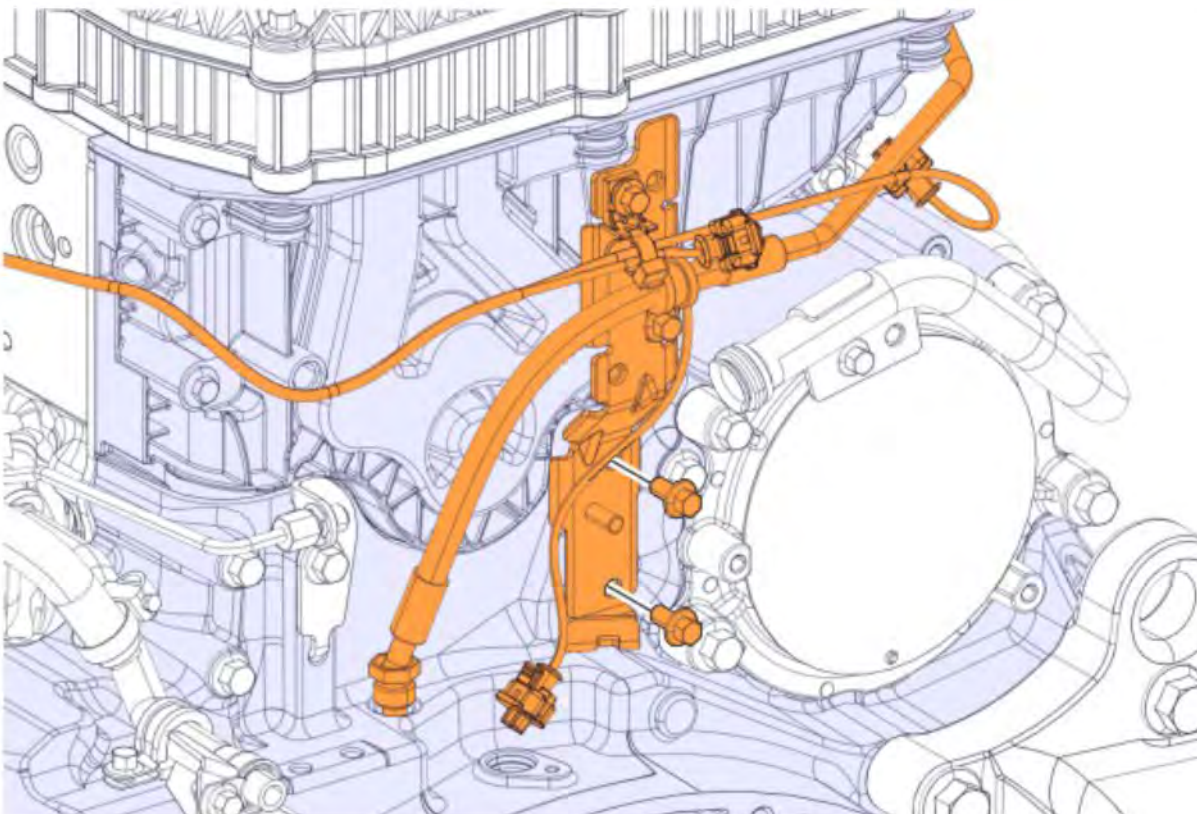

393 Install the cable ties.

i **Note**
Use new parts.

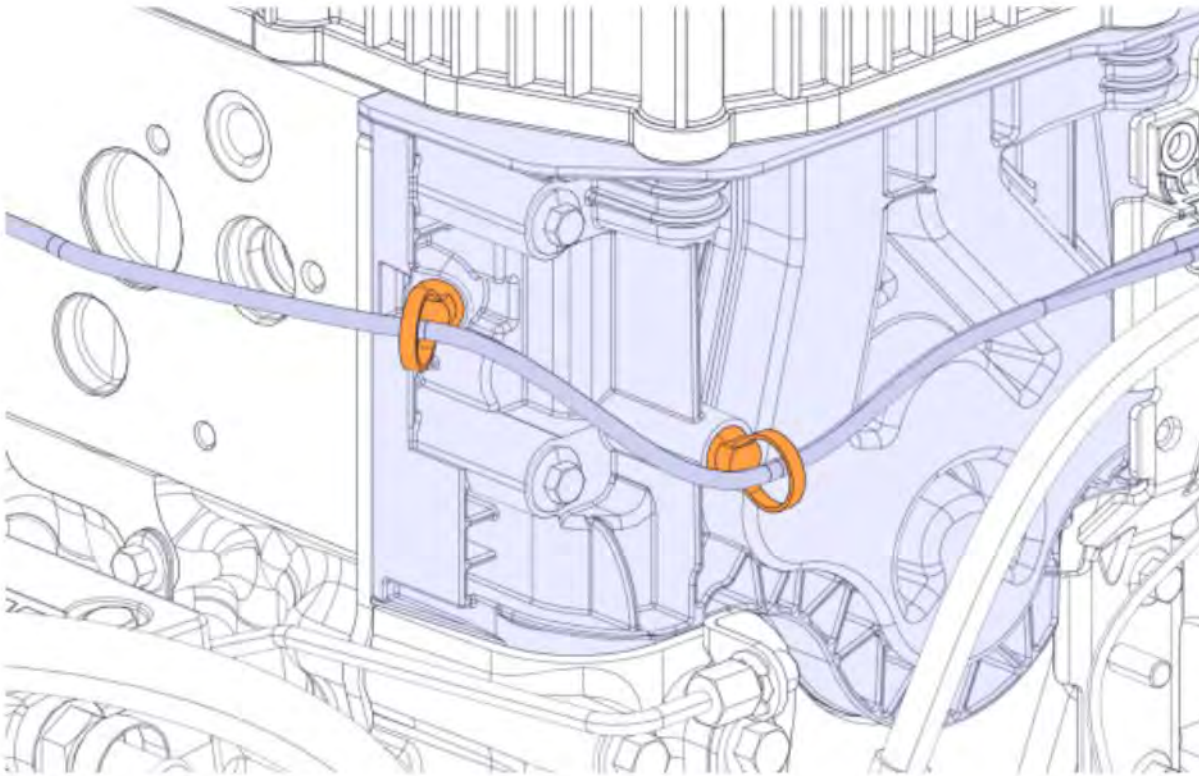

394	Install the hose.
------------	-------------------

395	Tighten the nut.
------------	------------------

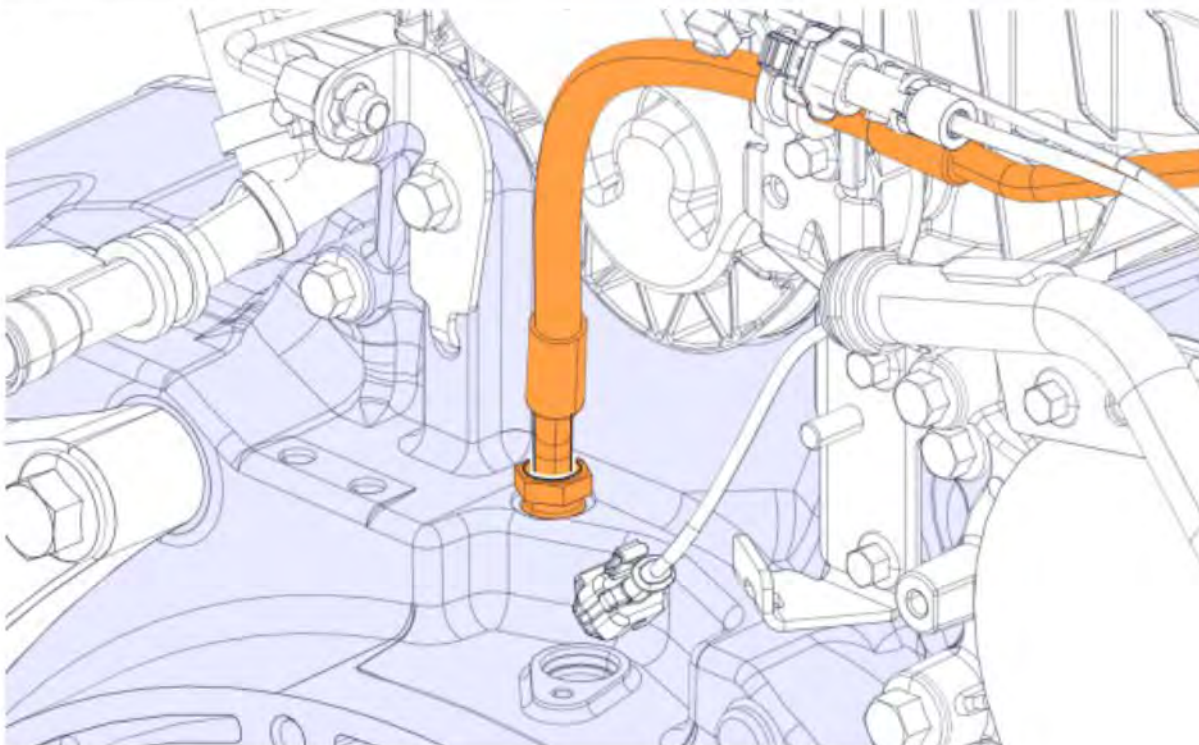

396	Clean the contact surface.
------------	----------------------------

397	Install the seal. <table border="1" style="margin-top: 10px;"> <tr> <td style="width: 30px; text-align: center;">i</td> <td>Note Use a new part.</td> </tr> </table>	i	Note Use a new part.
i	Note Use a new part.		

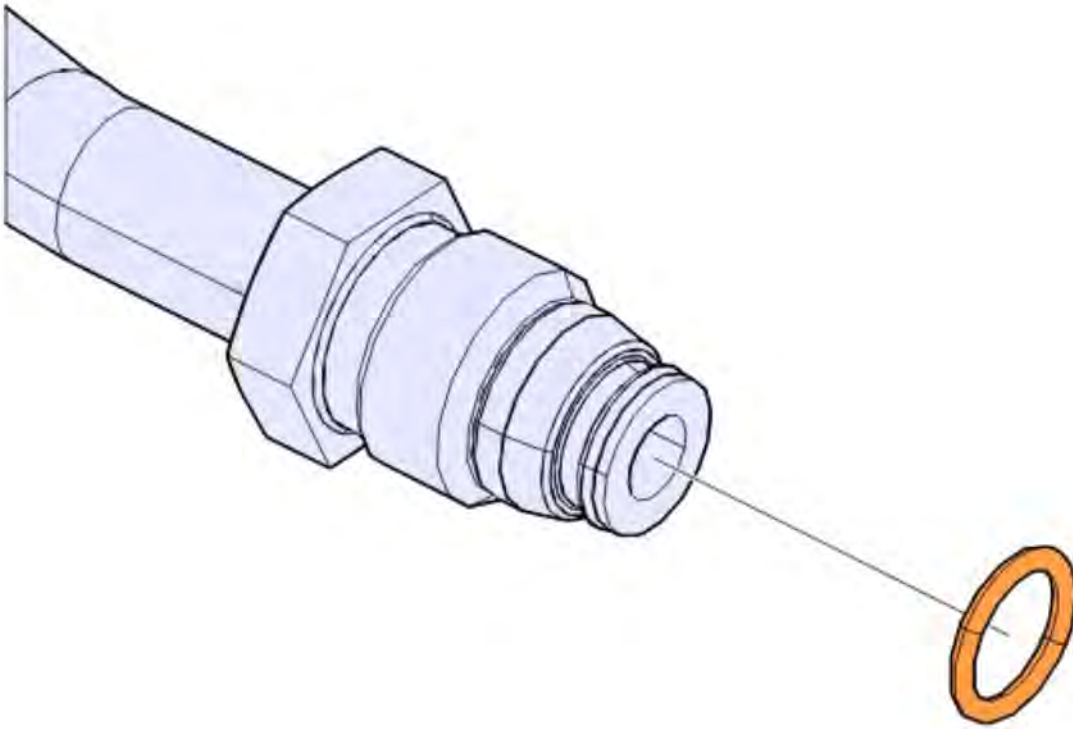

398	Install the pipes.
------------	--------------------

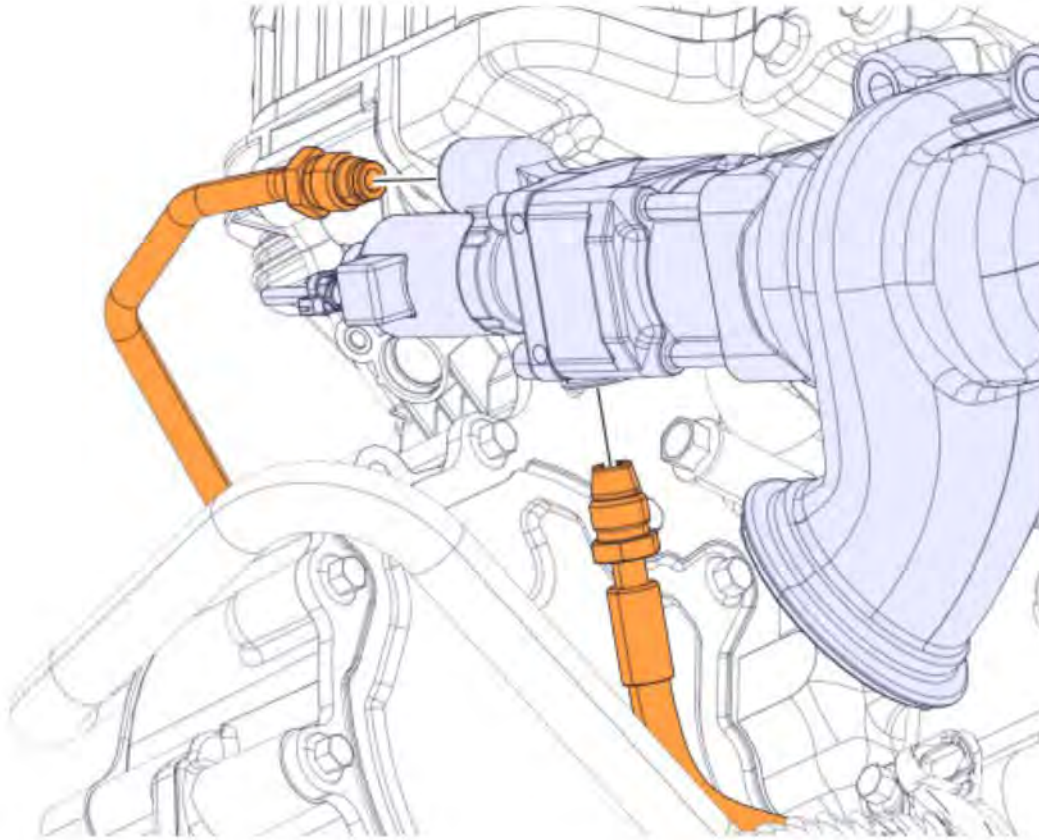

399 Install the gasket.



Note

Use a new part.

400 Position the valve.

401 Install the spacers.

402 Install the screws.



Note

Use the two upper fasteners to hold the gasket in place.

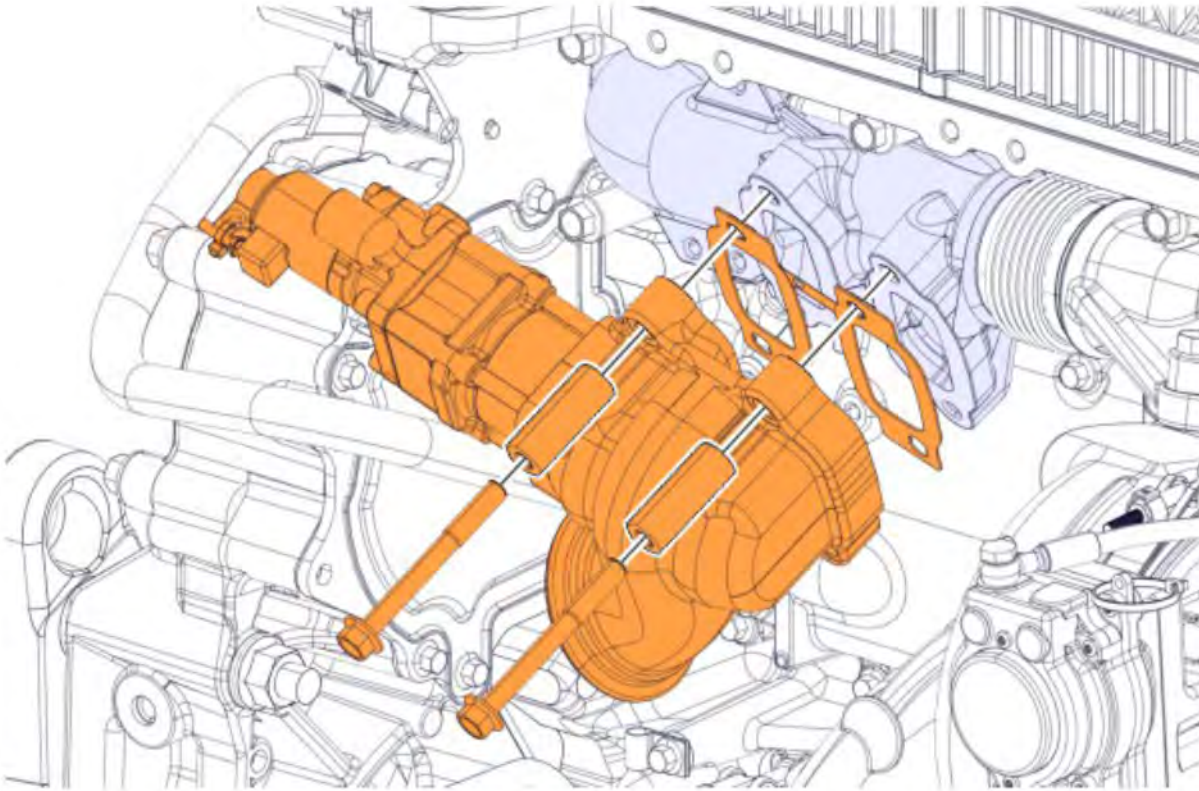

403	Install the spacers.
------------	----------------------

404	Install the screws.
------------	---------------------

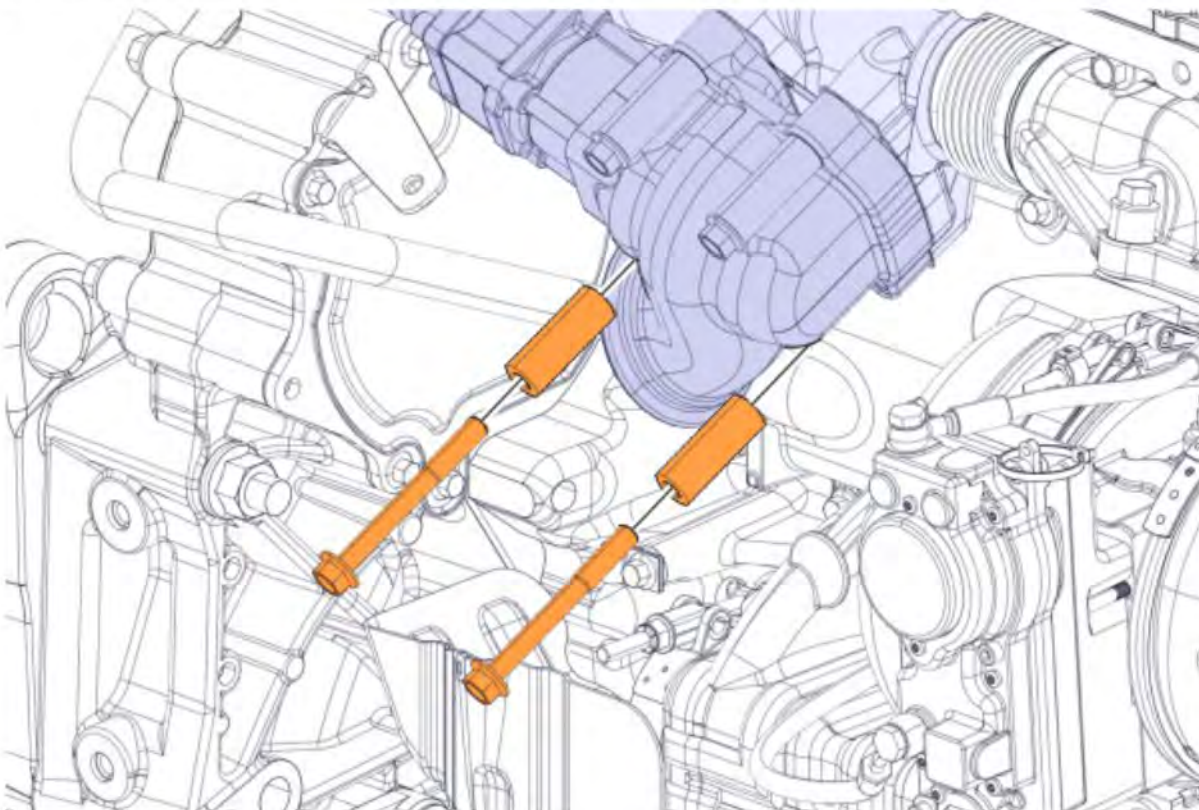

405	Torque tighten the screws.
------------	----------------------------

Tightening torque	
--------------------------	--

EGR valve, screw	1.	Tightening sequence: 1-4
------------------	----	--------------------------

		20 ±4 Nm (15 ±3 lb _f .ft)
	2.	Tightening sequence: 1-4
		52 ±4 Nm (38 ±3 lb _f .ft)

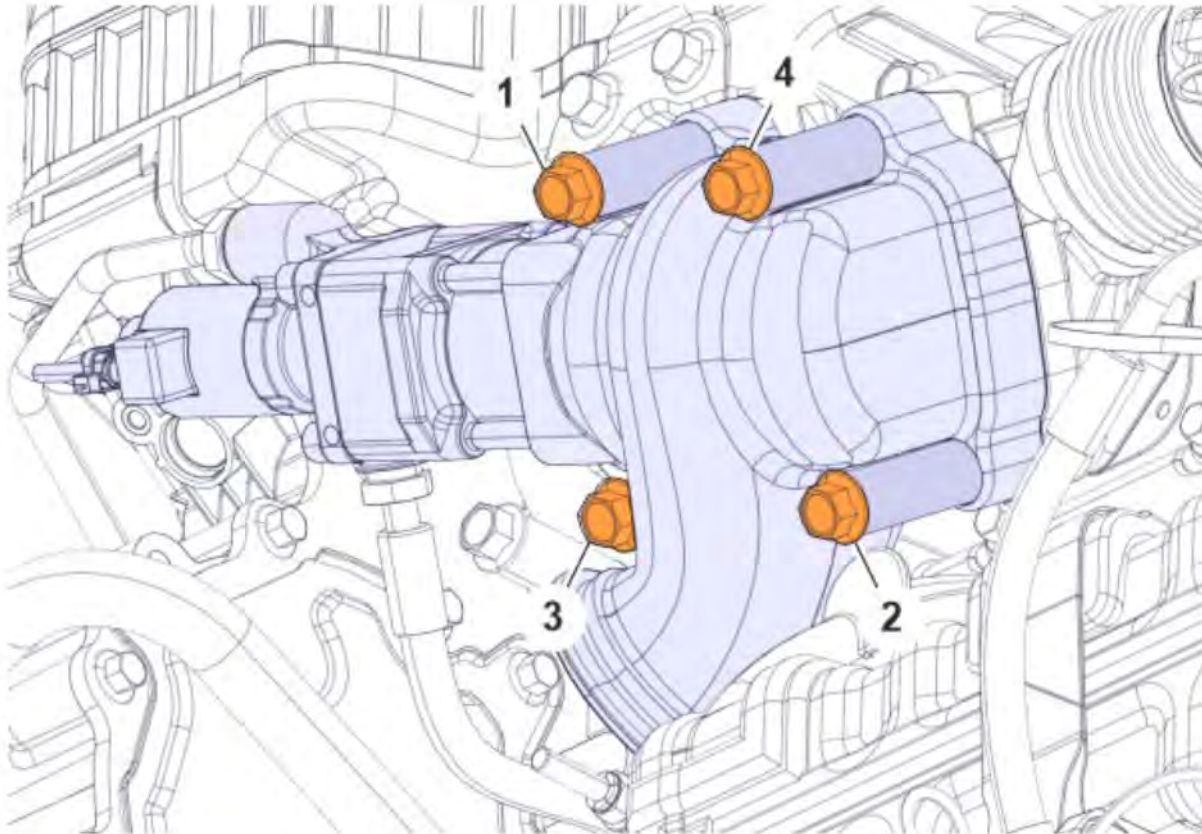

406	Torque tighten the pipe.	
	Tightening torque	
	EGR valve, nipple	25 ±4 Nm (18 ±3 lb _f .ft)

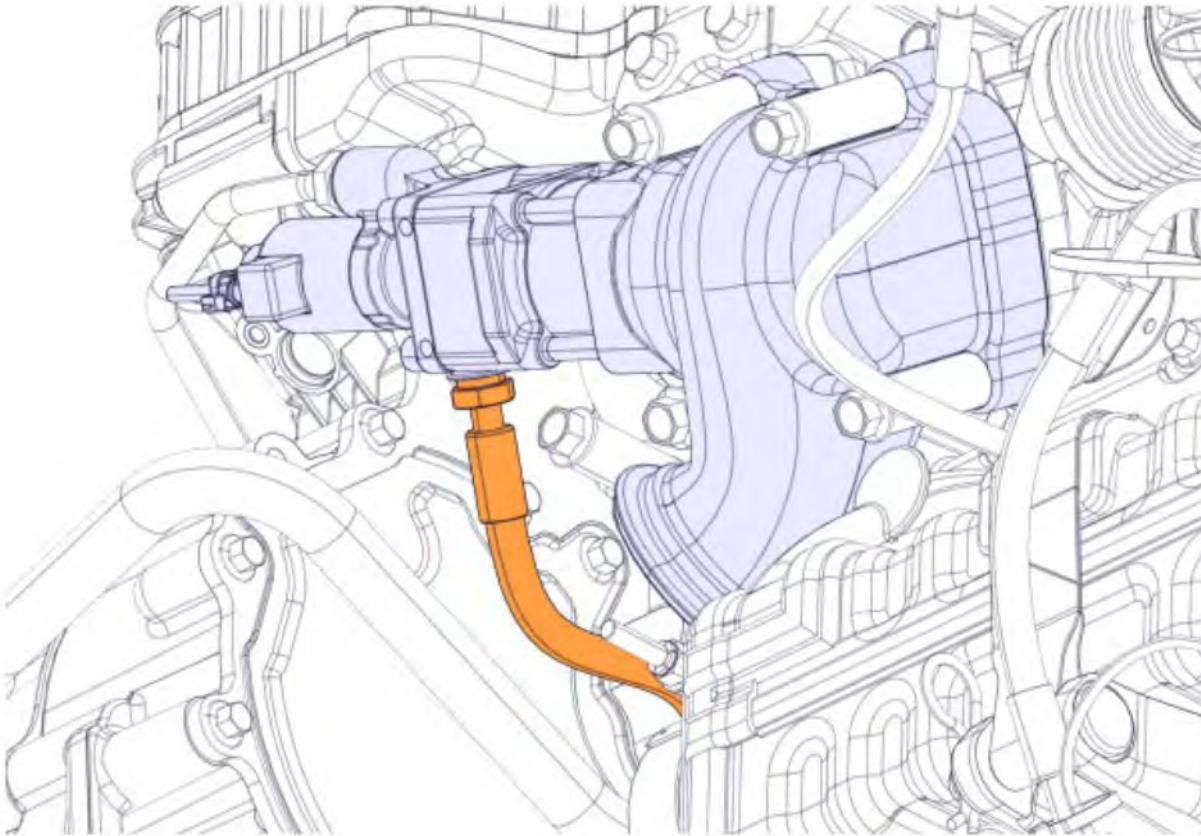

407	Torque tighten the pipe.	
Tightening torque		
	EGR valve, nipple	25 ±4 Nm (18 ±3 lb _f ·ft)

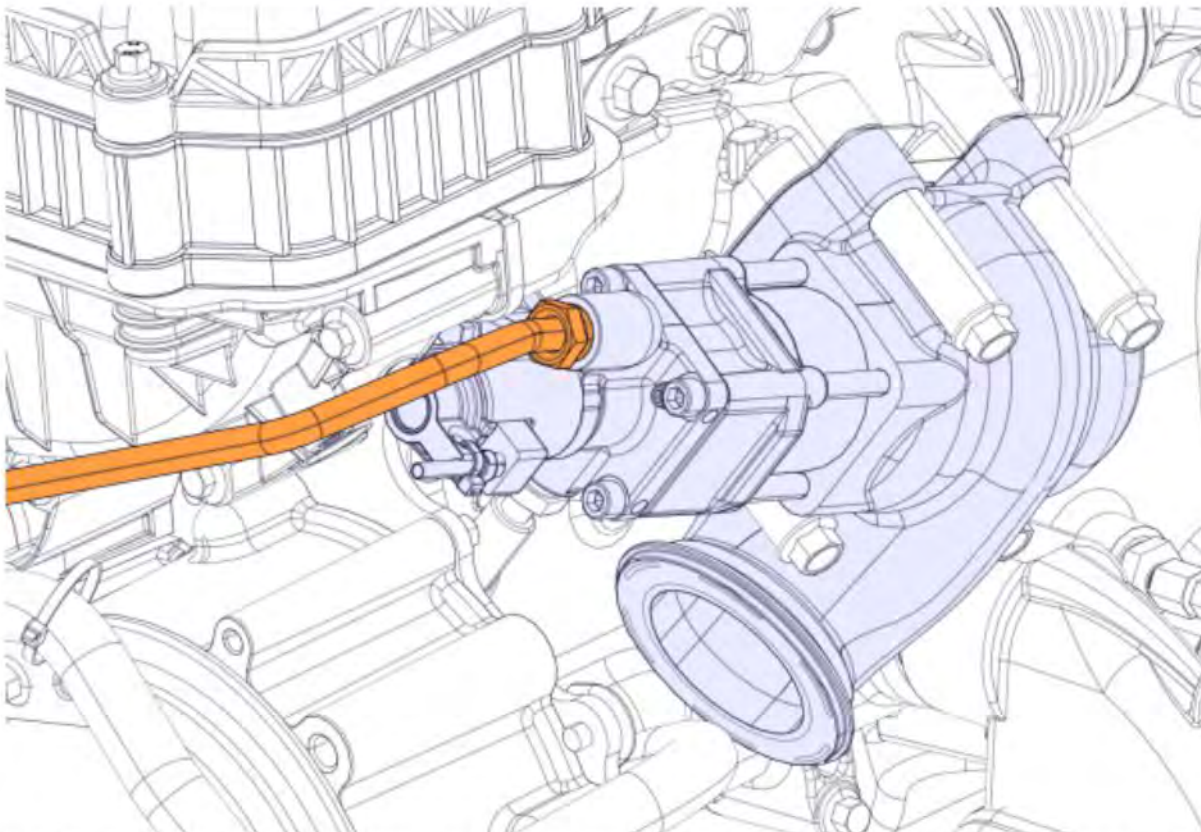

Copyright to this documentation belongs to the Volvo Group. No reproduction, copying, change, amendment or other similar disposal is entitled without prior written consent by the Volvo Group

The information contained herein is current at the time of its original distribution, but is subject to change. The reader is advised that printed copies are uncontrolled.

408	Position the cable.
-----	---------------------

409	Connect the connector.
-----	------------------------

410	Install the cable ties.
-----	-------------------------

**Note**

Use new parts.

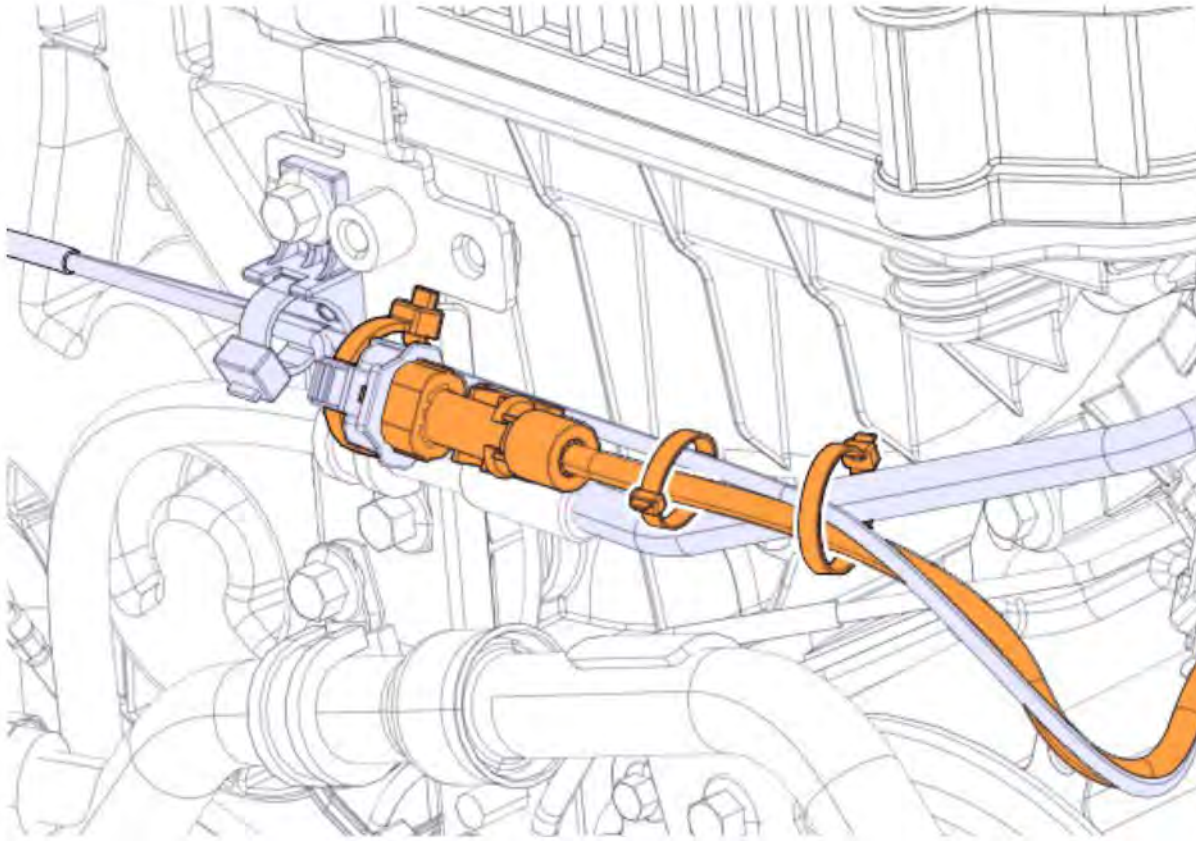

411	Clean the contact surfaces.
-----	-----------------------------

412	Install the gaskets.
-----	----------------------

**Note**

Use new parts.

413	Install the pipe.
-----	-------------------

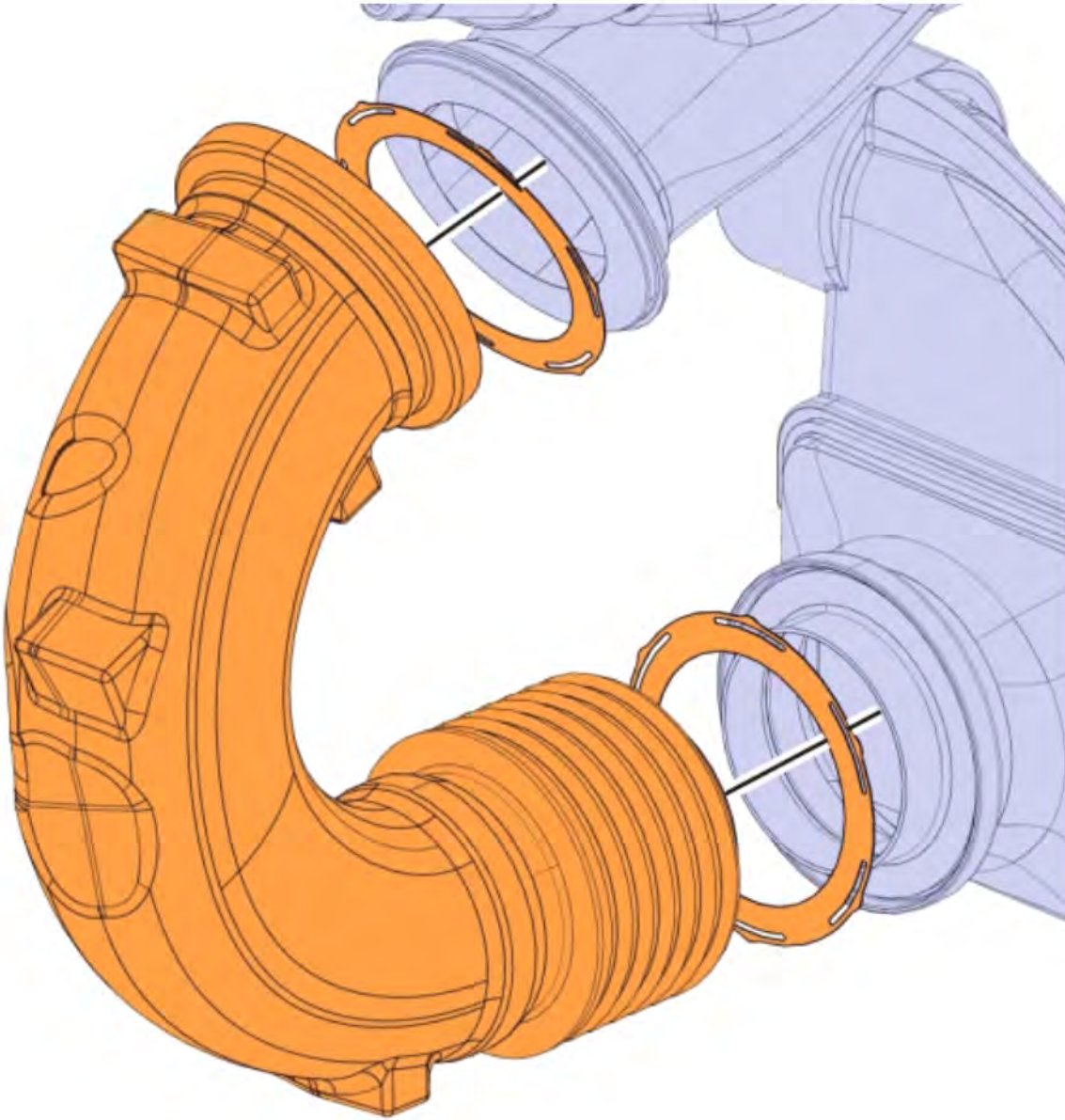

414	Check that the gaskets are positioned correctly.
-----	--

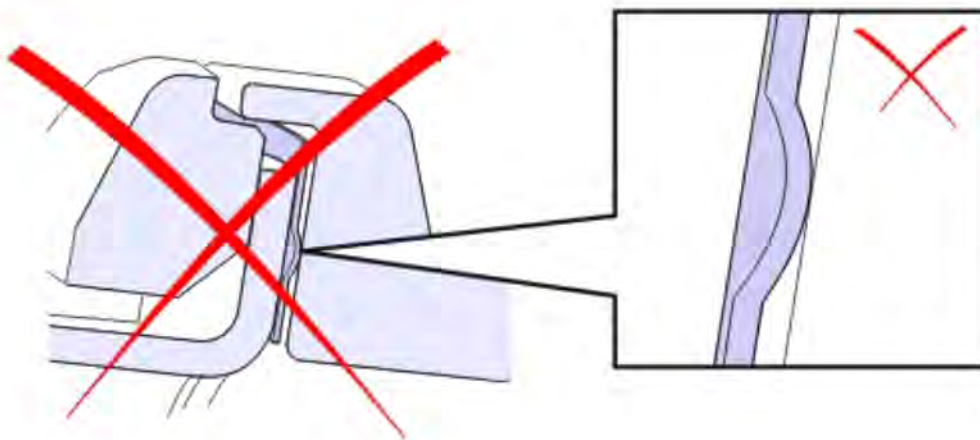
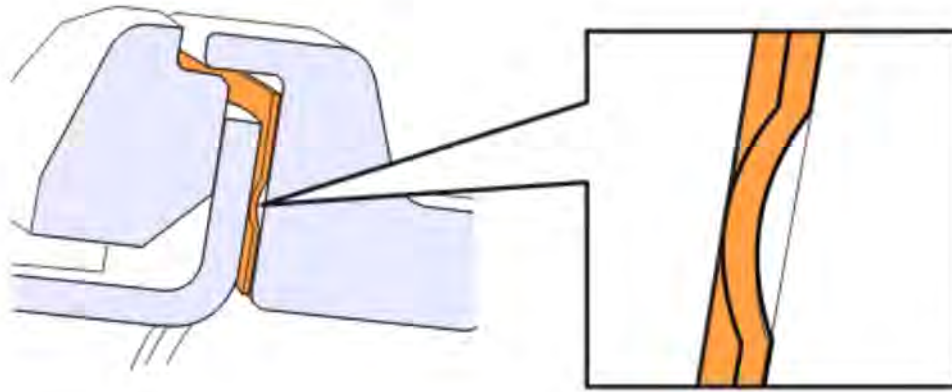

415	Install the V-clamps.
<div style="border: 1px solid black; padding: 2px; margin-bottom: 5px;"> i Note Install as marked. </div>	
<div style="border: 1px solid black; padding: 2px;"> i Note Use new parts. </div>	

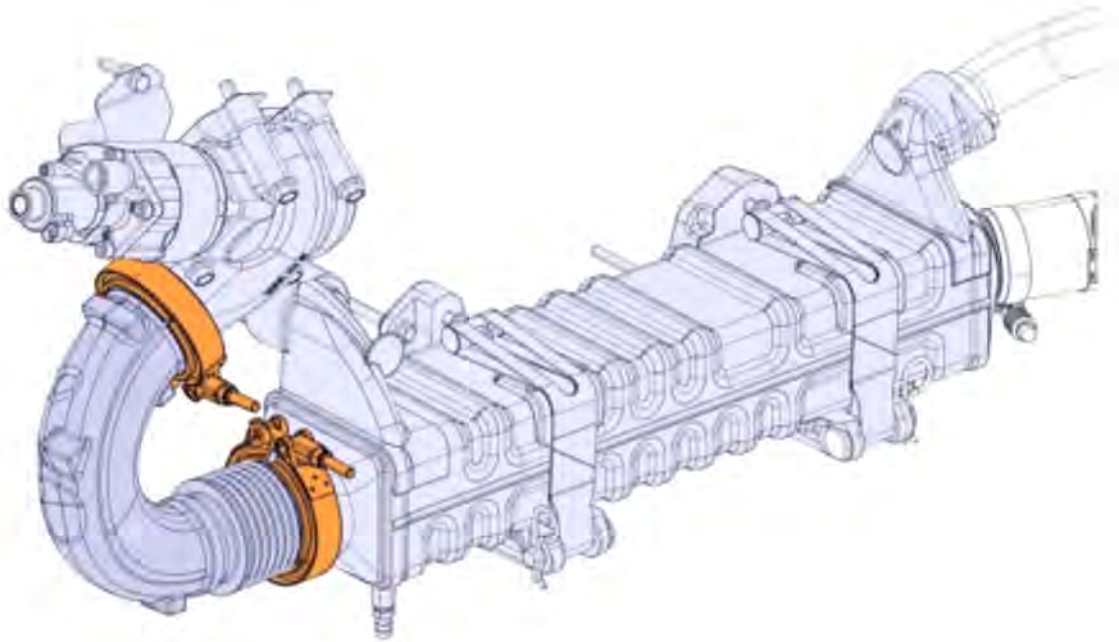
**CAUTION****Risk of material damage.**

Incorrect installation of the gasket or collar will cause exhaust leakage. The exhaust leakage could damage components in the surrounding area.

- ▶ Pay close attention to installing the inlet pipe correctly. Ensure that the gasket and collar are positioned correctly.

416 Check before tightening that the sliding collar is centered in the cooler flange.

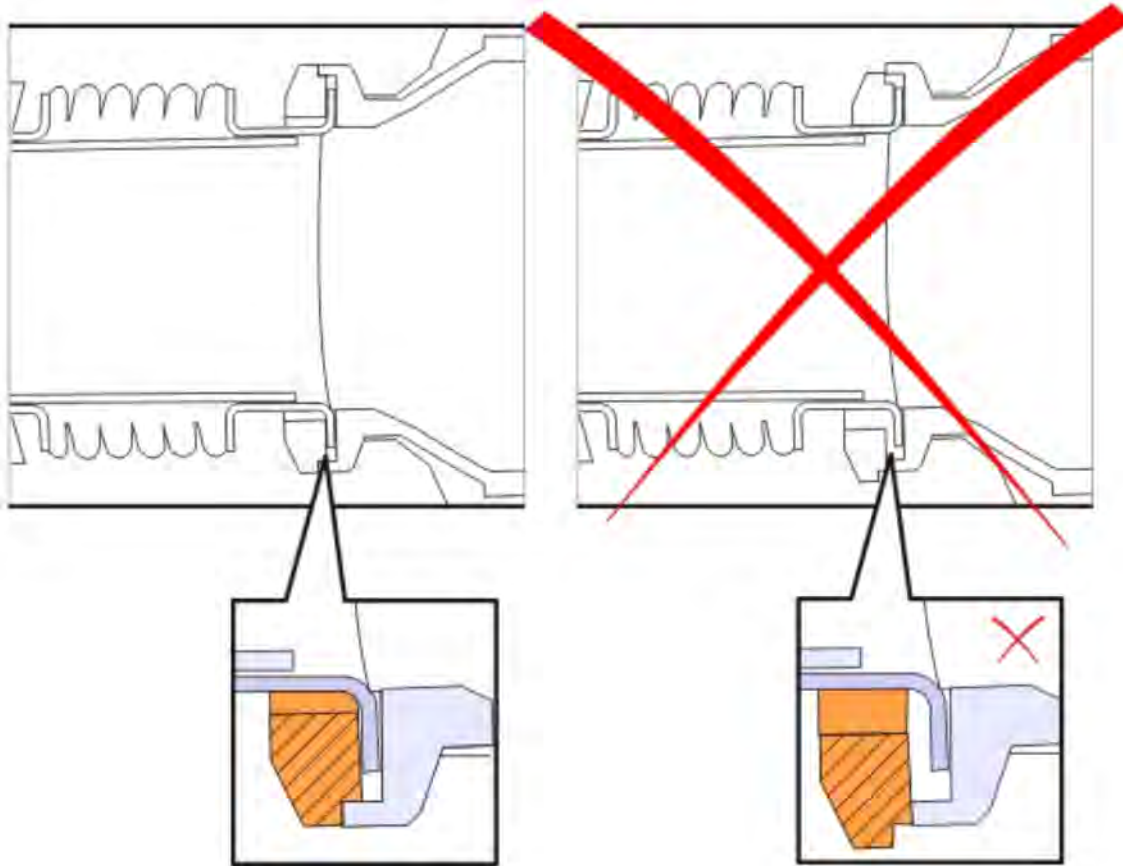



417	Torque tighten the V-clamps.			
	Tightening torque			
	V-clamp, screw	20 ±4 Nm (15 ±3 lb _f -ft)		
<table border="1" style="width: 100%;"> <tr> <td style="text-align: center;">i</td> <td>Note After tightening, check the position of the V-clamps.</td> </tr> </table>			i	Note After tightening, check the position of the V-clamps.
i	Note After tightening, check the position of the V-clamps.			

418 Install the heat shield.

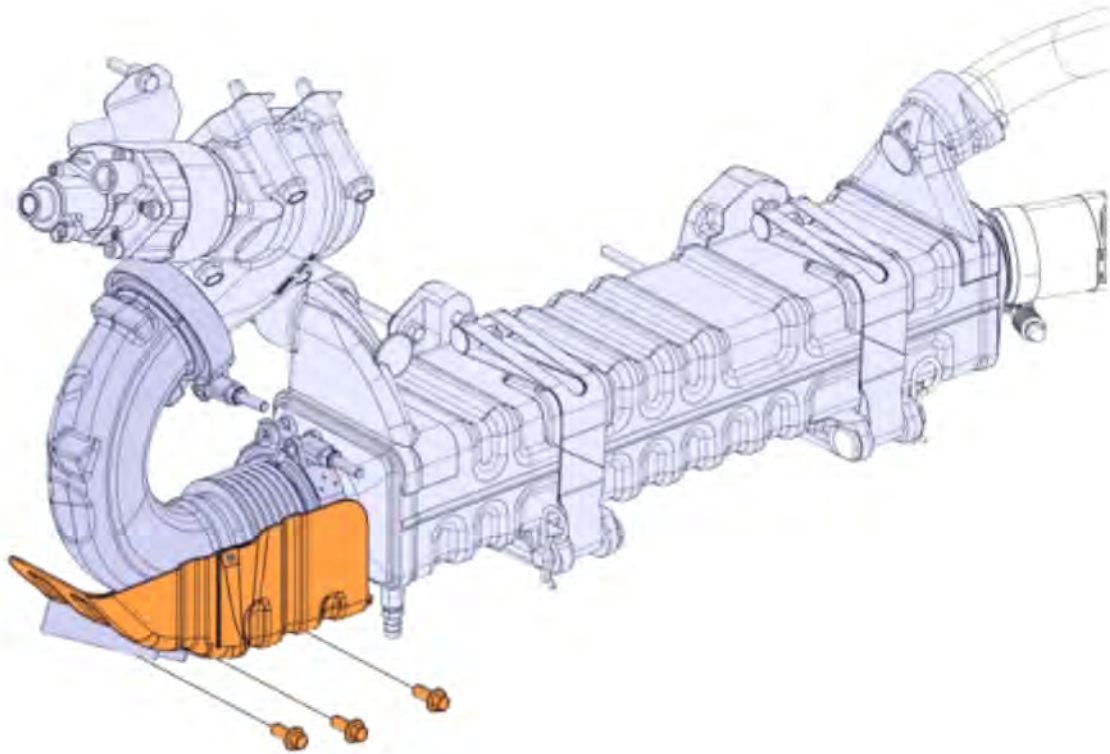
419 Install the screws.



420	Clean the mating surfaces.		
421	Install the gasket. <table border="1"><tr><td></td><td>Note Use a new part.</td></tr></table>		Note Use a new part.
	Note Use a new part.		
422	Install the diffuser.		

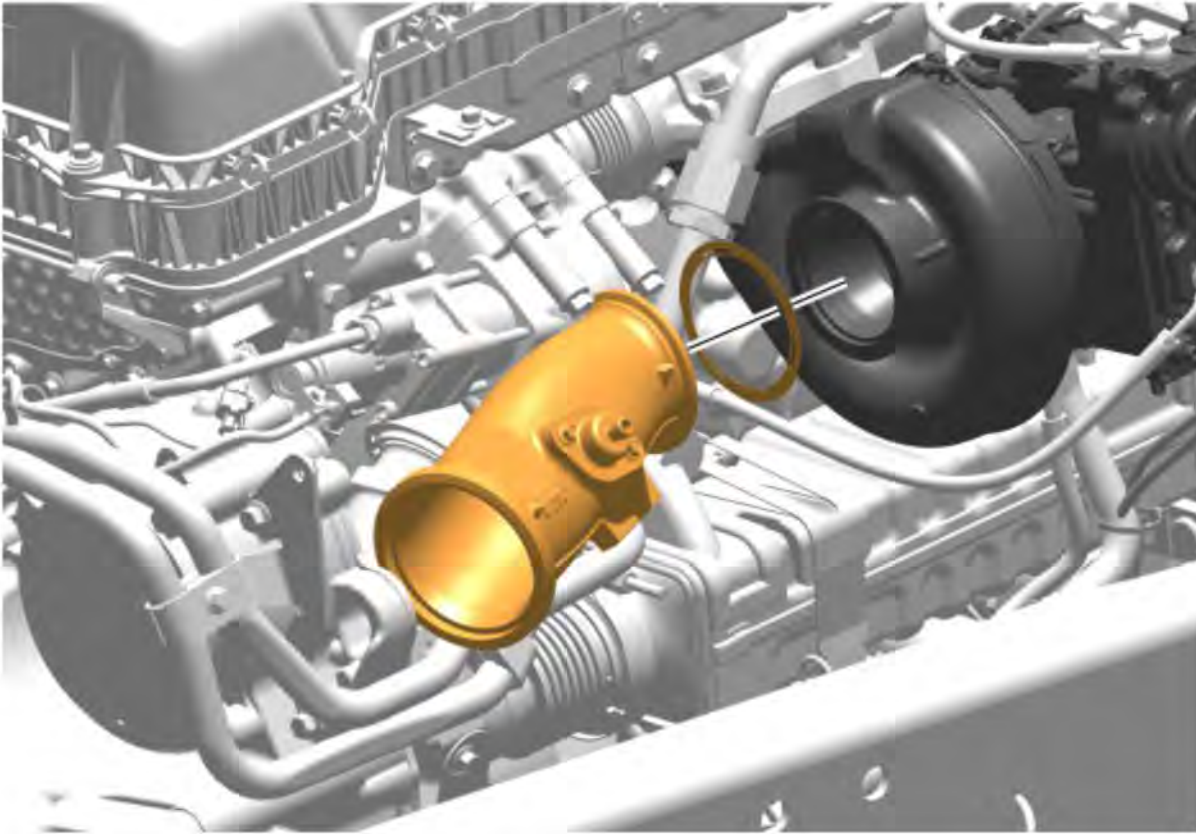

423 Install the clamp.



Note

Use a new part.



Note

Seat the clamp by tapping it into place between tightening sequences.



Note

Only use a suitable hand tool.

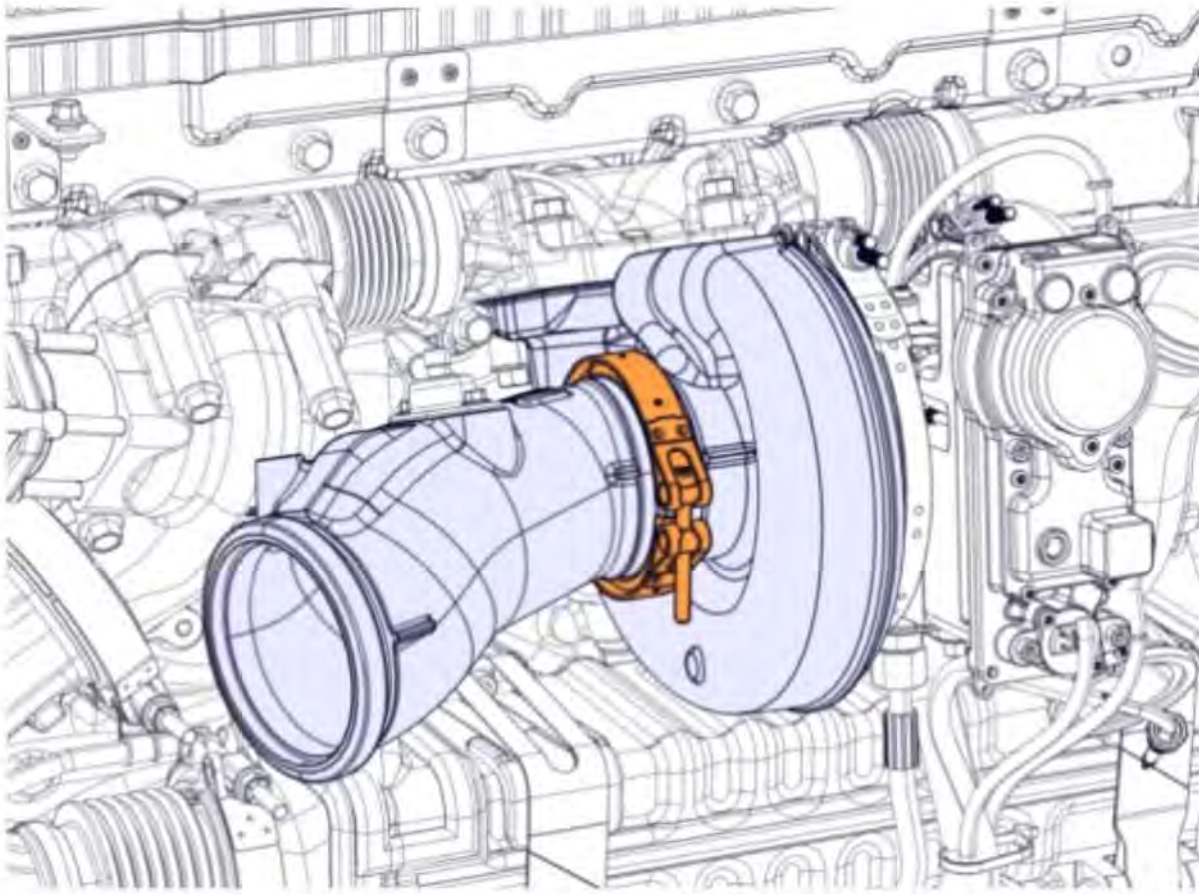

⚠ DANGER

Risk of material damage, serious personal injury or death.

Connections that are not tightened in accordance with specified tightening torques may cause leakage.

► Tighten connections according to service information.

424	Torque tighten the clamp in sequence.	
	Tightening torque	
	V-clamp, pre-torque	7 Nm (5 lb _f ·ft)

425	Seat the clamp by tapping it into place between tightening sequences.	
	Tightening torque	
	V-clamp, final torque	14 ±2 Nm (10 ±1 lb _f ·ft)

426 This step contains 2 alternatives.
Select one of the valid alternatives below.

Copyright to this documentation belongs to the Volvo Group. No reproduction, copying, change, amendment or other similar disposal is entitled without prior written consent by the Volvo Group

The information contained herein is current at the time of its original distribution, but is subject to change. The reader is advised that printed copies are uncontrolled.

Alternative 1 / 2**Conditions**

- If the pipe is reused
- ▶ Clean the pipe mating surfaces.
- ▶ Install the gaskets.



Note
Use new parts.



- ▶ Install the pipe.



Note
As noted.

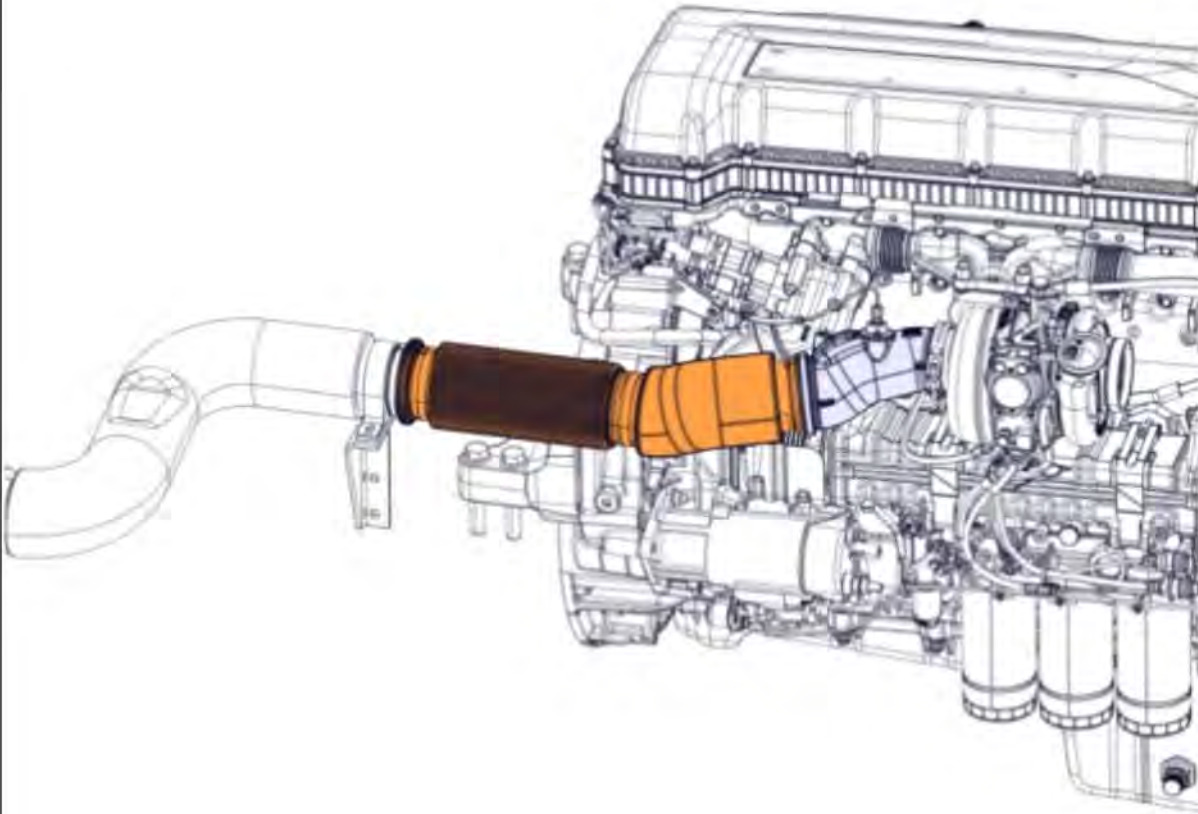

▶ Install the clamps.



Note
Use new parts.



Note
As noted.

▶ Torque tighten the clamps.

Tightening torque

Pipe, clamp	5.6 Nm (4 lb _f ·ft)
-------------	-----------------------------------

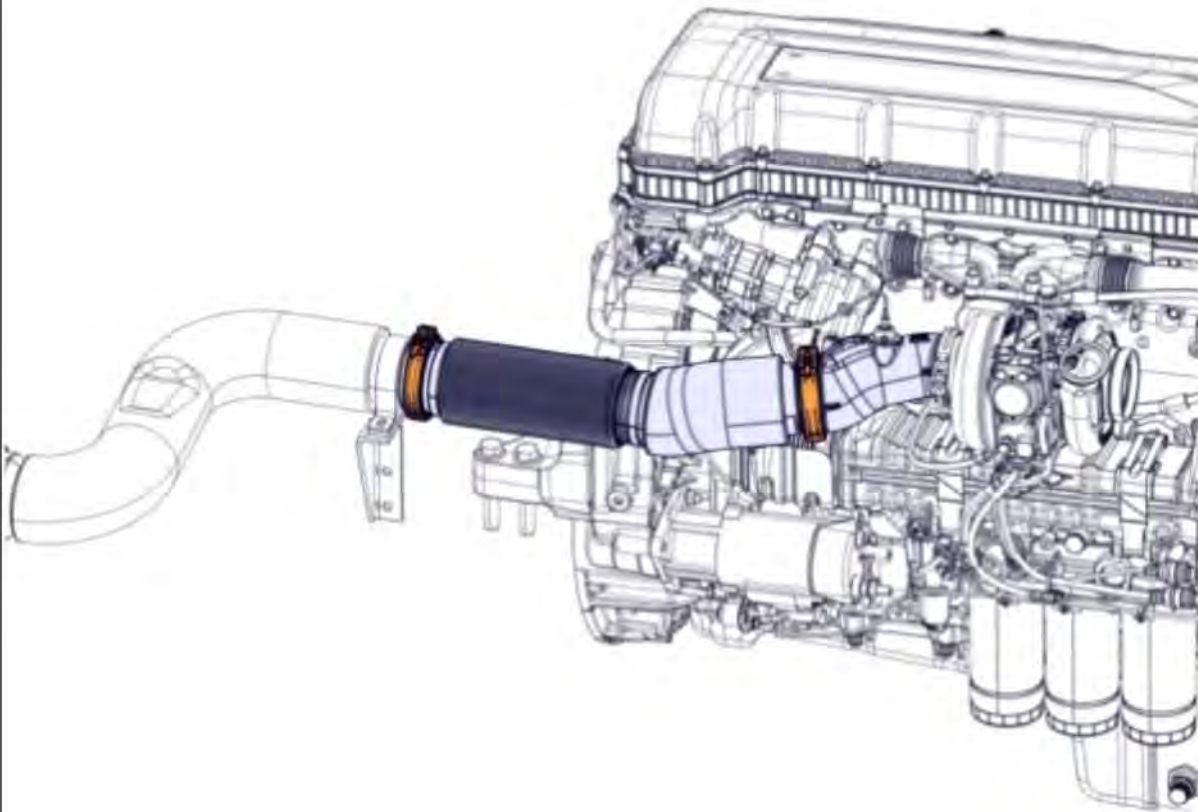
**Alternative 2 / 2****Conditions**

- If the pipe is replaced

- ▶ Clean the surface.

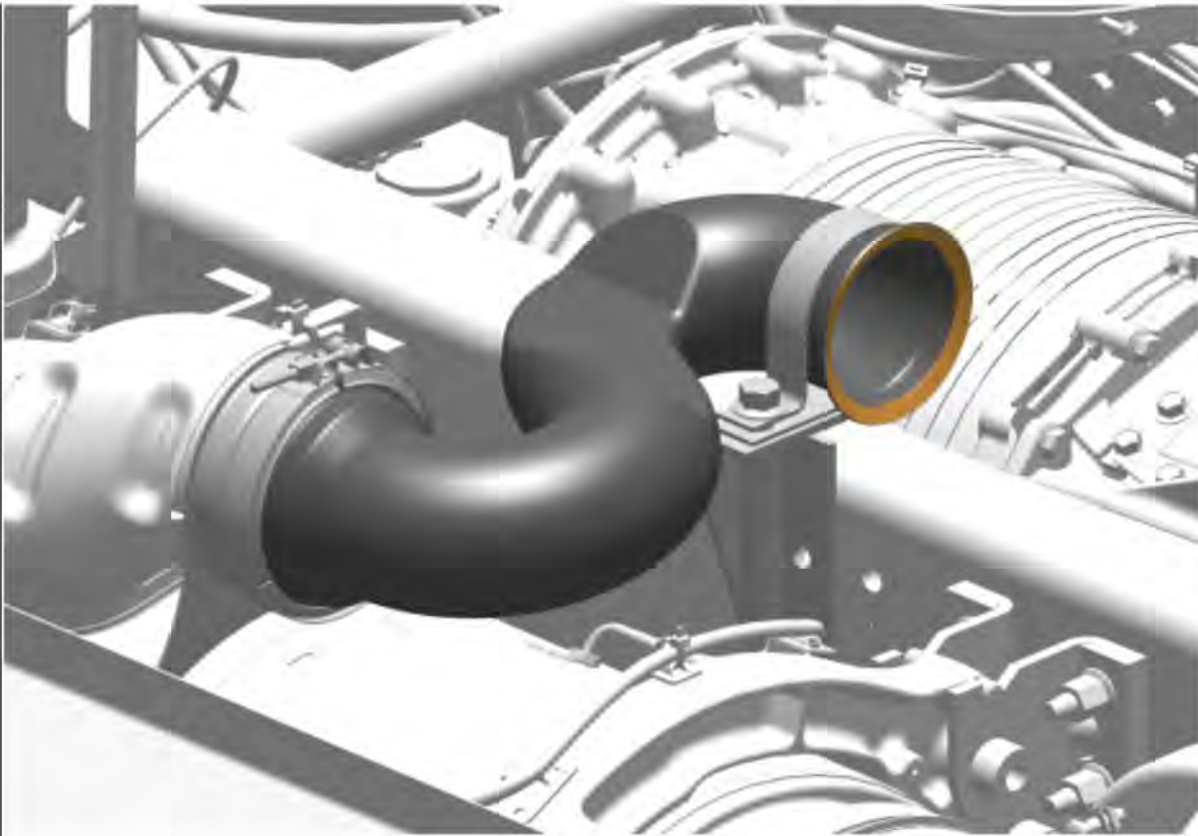

- ▶ Check the length (A) of the flexible hose.

Tech data

Flexible hose, length (A)	267 ±10 mm (10.51 ±0.39 in)
---------------------------	--------------------------------



Note

Ensure that the length is according to the specification.

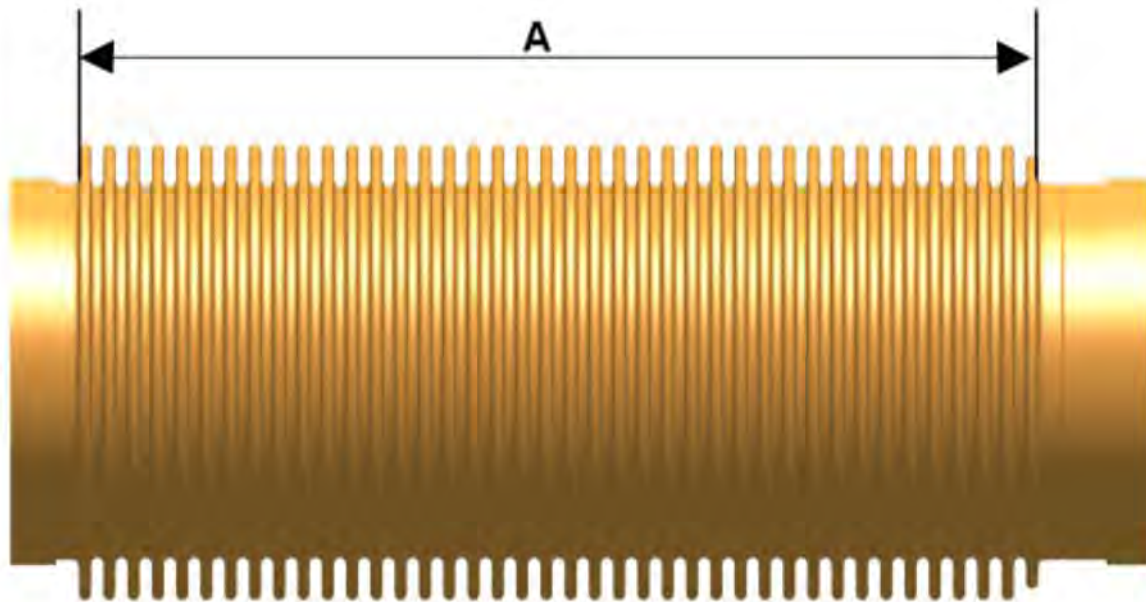

► Position the exhaust pipe.



Note

Use a new gasket.



Note

The markings indicate the flow direction.



Note

The exhaust pipe should be fixed as straight as possible.



Note

Ensure that flexible hose is not twisted or bent more than the specification.



Service hint

Ensure that 11 L engines are aligned with Red line.

Ensure that 13 L engines are aligned with Black line.

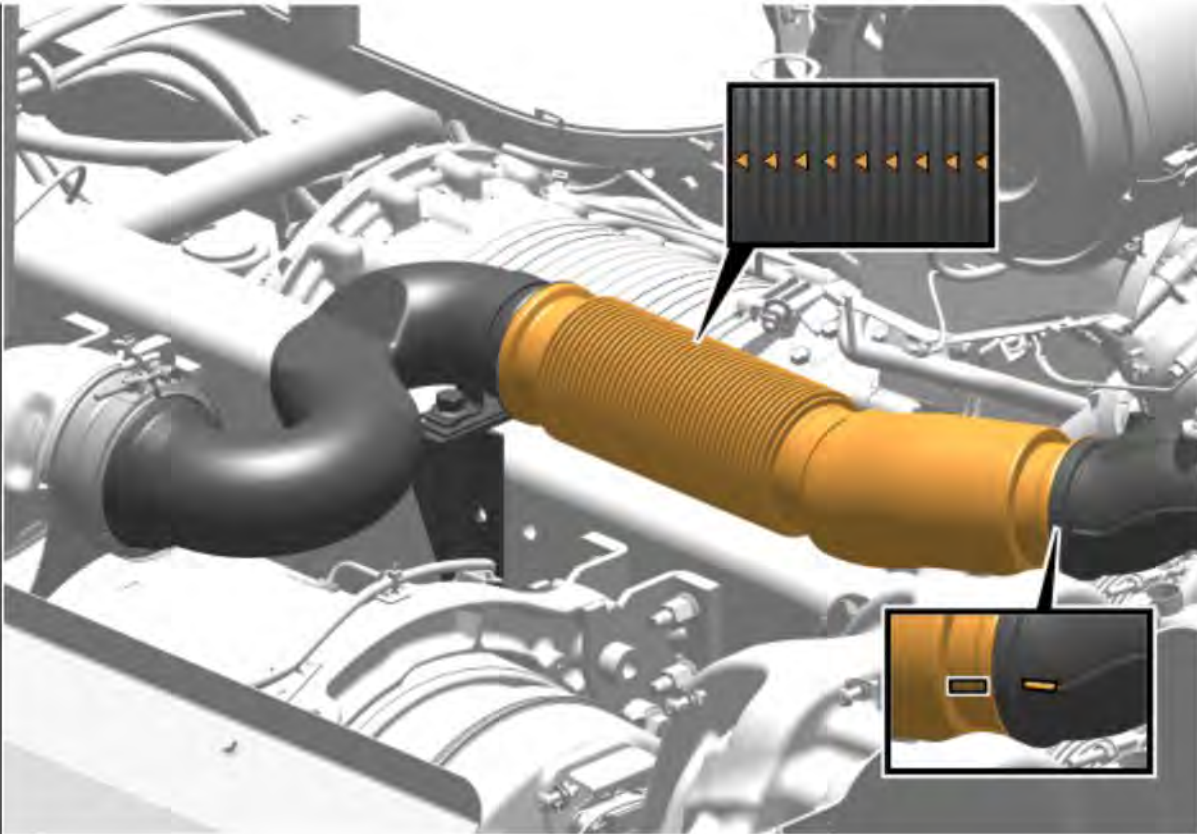

▶ Install the V-clamps.



Note

Use new parts.



Note

As noted.



Note

Do not torque tighten the V-clamps.

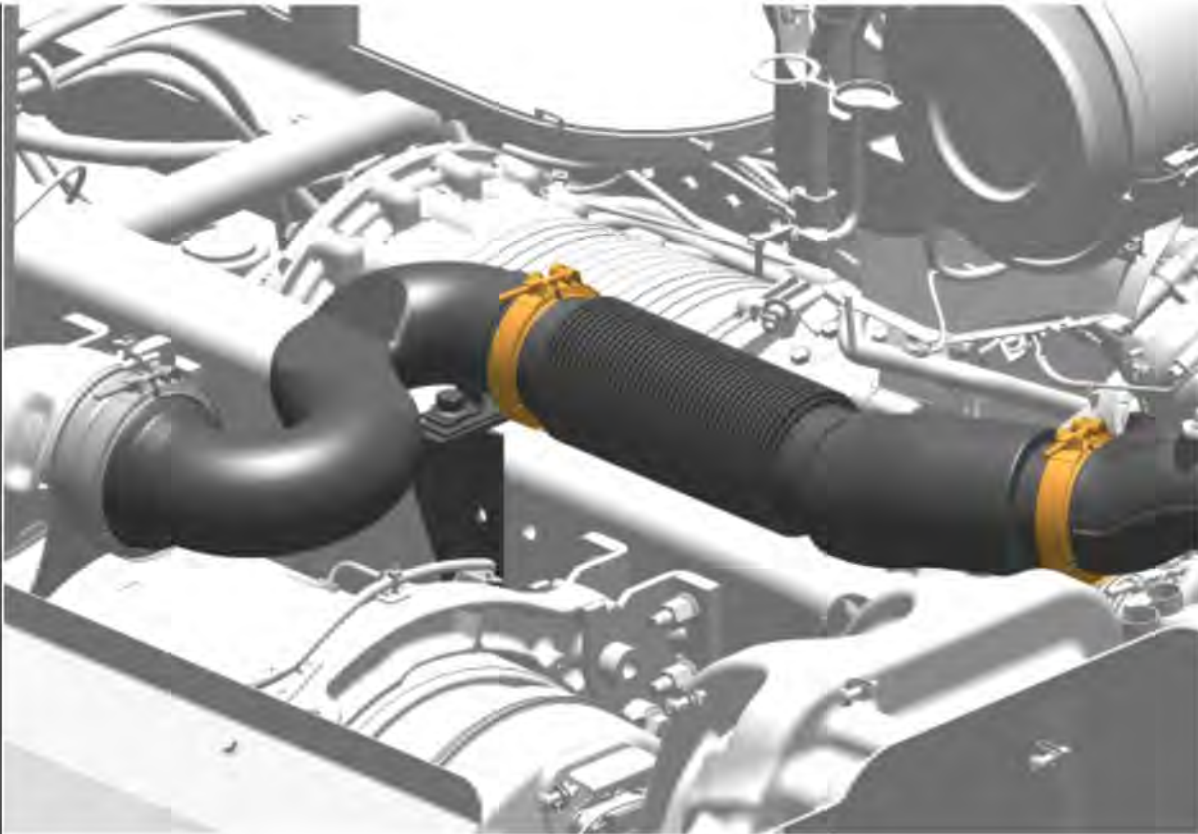

- ▶ Check the alignment of the flexible hose.

Tech data

Flexible hose, torsion displacement (A)	±2 mm (±0.08 in)
Flexible hose, parallel displacement (B)	±5 mm (±0.2 in)
Flexible hose, axial displacement (C)	±6.5 mm (±0.256 in)

i **Note**
Ensure that the flexible hose is aligned according to specifications.

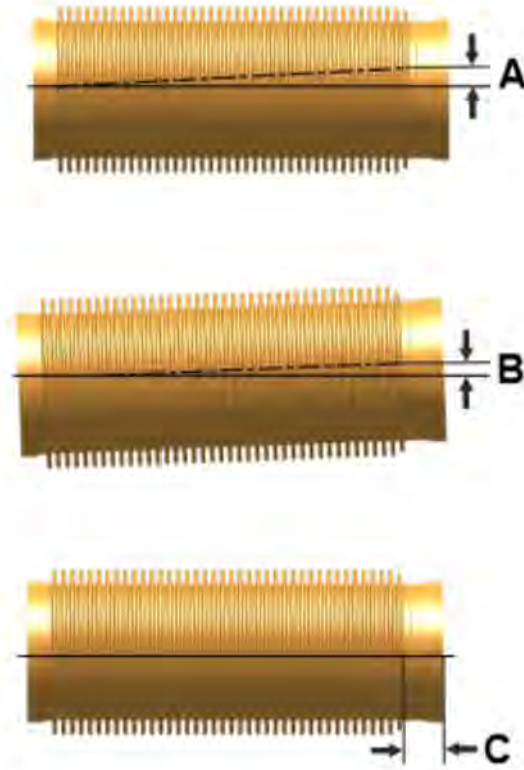

► Perform this procedure when the condition below is met.

Conditions

- If the flexible hose length and alignment is not according to the specification

► Loosen the exhaust pipe at the turbocharger end and align as per specifications.

► Torque tighten the V-clamps.

Tightening torque

Pipe, clamp	5.6 Nm (4 lb _f ·ft)
-------------	-----------------------------------

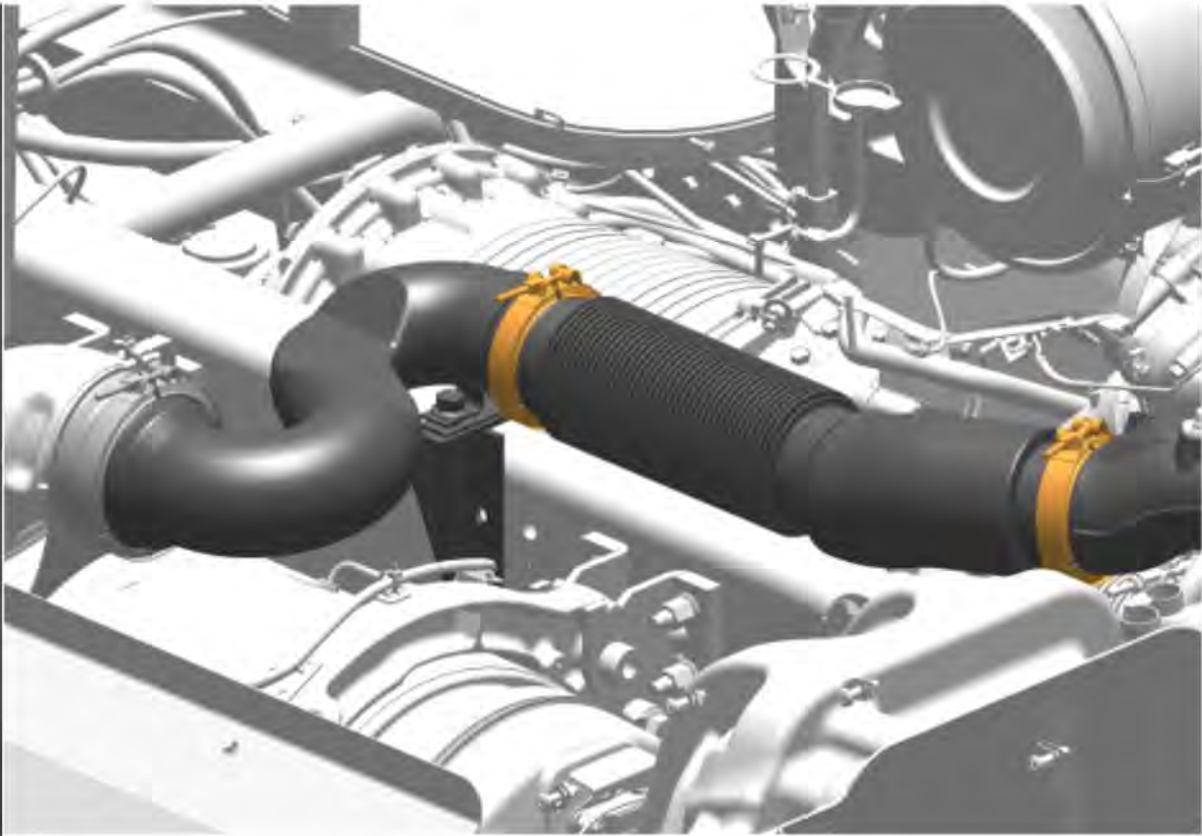

427 Install the starter motor.

428 Install the nuts.

429 Tighten the nuts to torque.

Tightening torque	
Starter motor, nut	48 ±8 Nm (35 ±6 lb _f .ft)

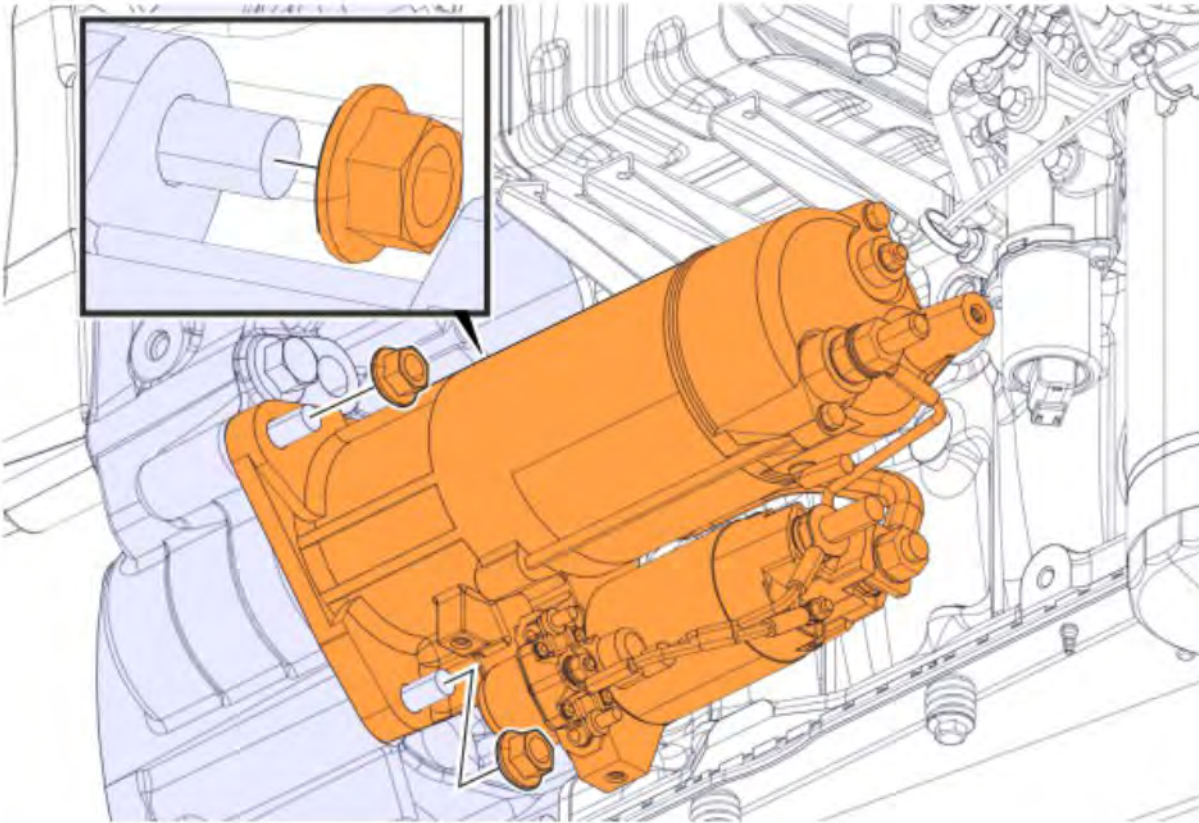

430	Install the cable terminals.
------------	------------------------------

431	Install the nuts.
------------	-------------------

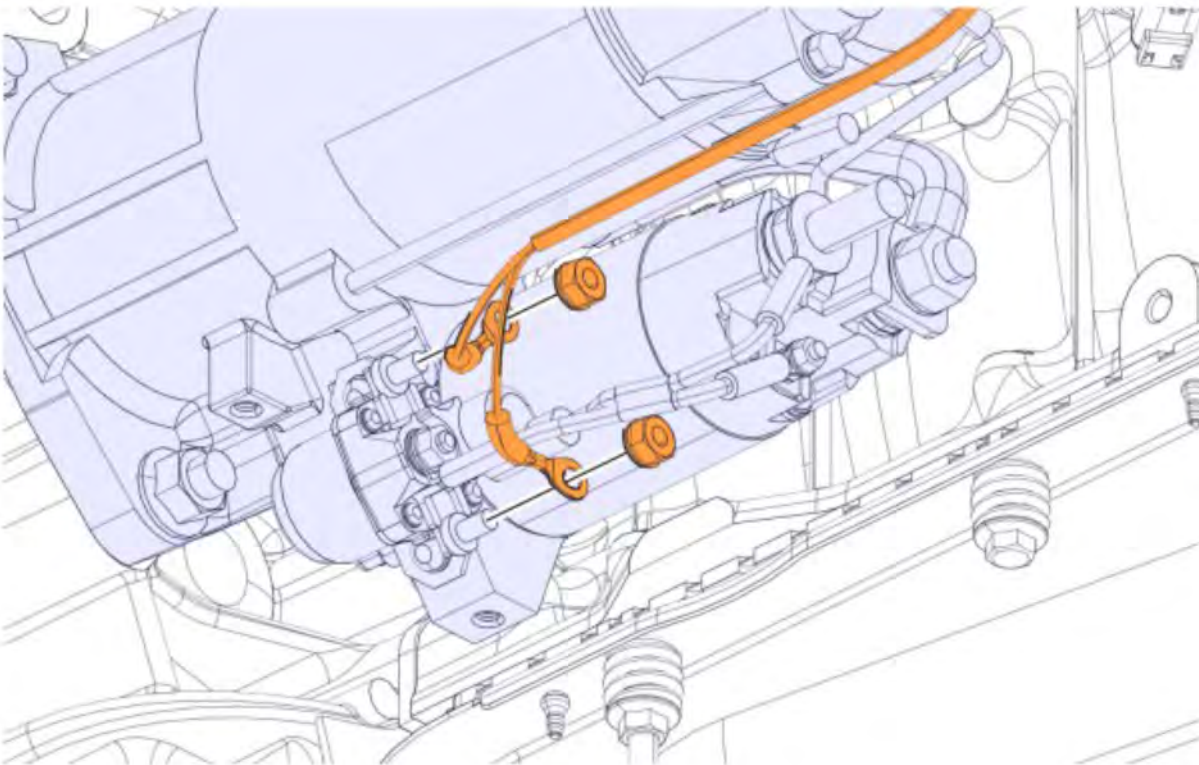

432	Install the cable terminal.
------------	-----------------------------

433	Install the nut.
------------	------------------

434	Torque tighten the nut.
------------	-------------------------

Tightening torque	
Starter solenoid, terminal, nut	M10
	18 ±3.6 Nm (13 ±3 lb _f .ft)
Tightening torque	
Starter solenoid, terminal, nut	M12
	25 ±5 Nm (18 ±4 lb _f .ft)

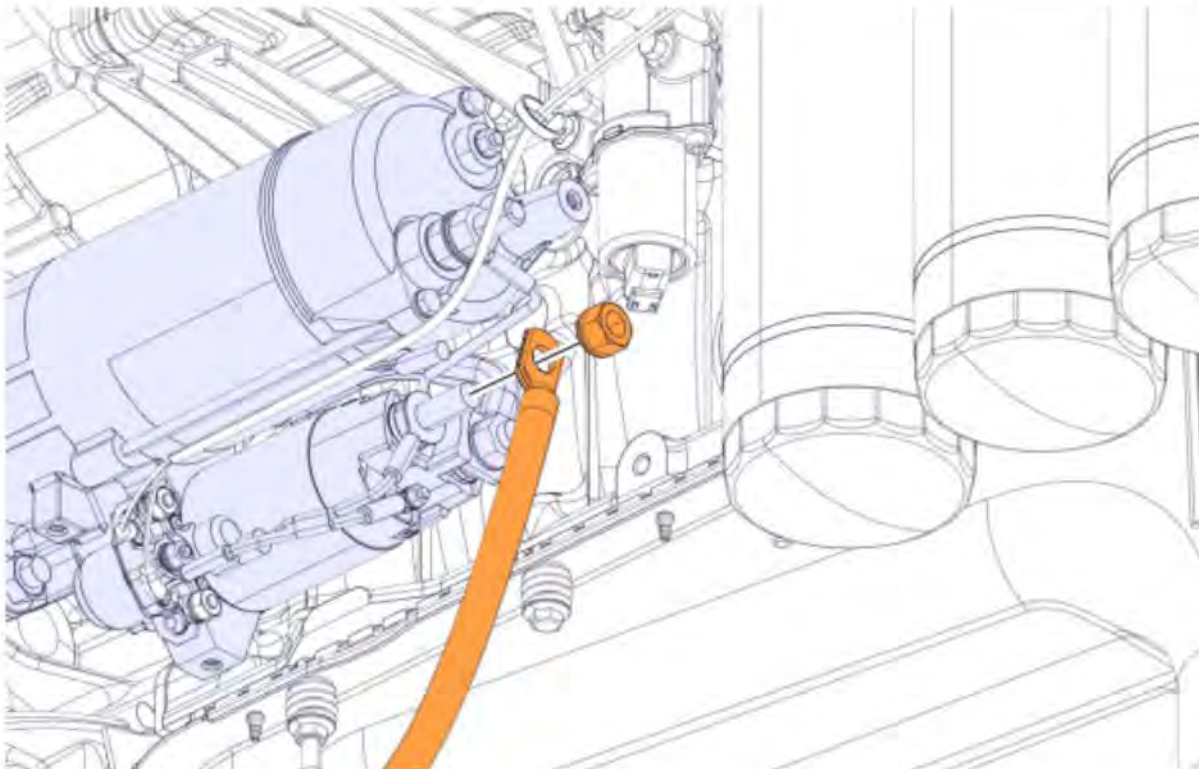

435	Position the pipe.
i	Note The pipe can be reused only a limited number of times.
i	Note If there are no clips, replace the pipe.

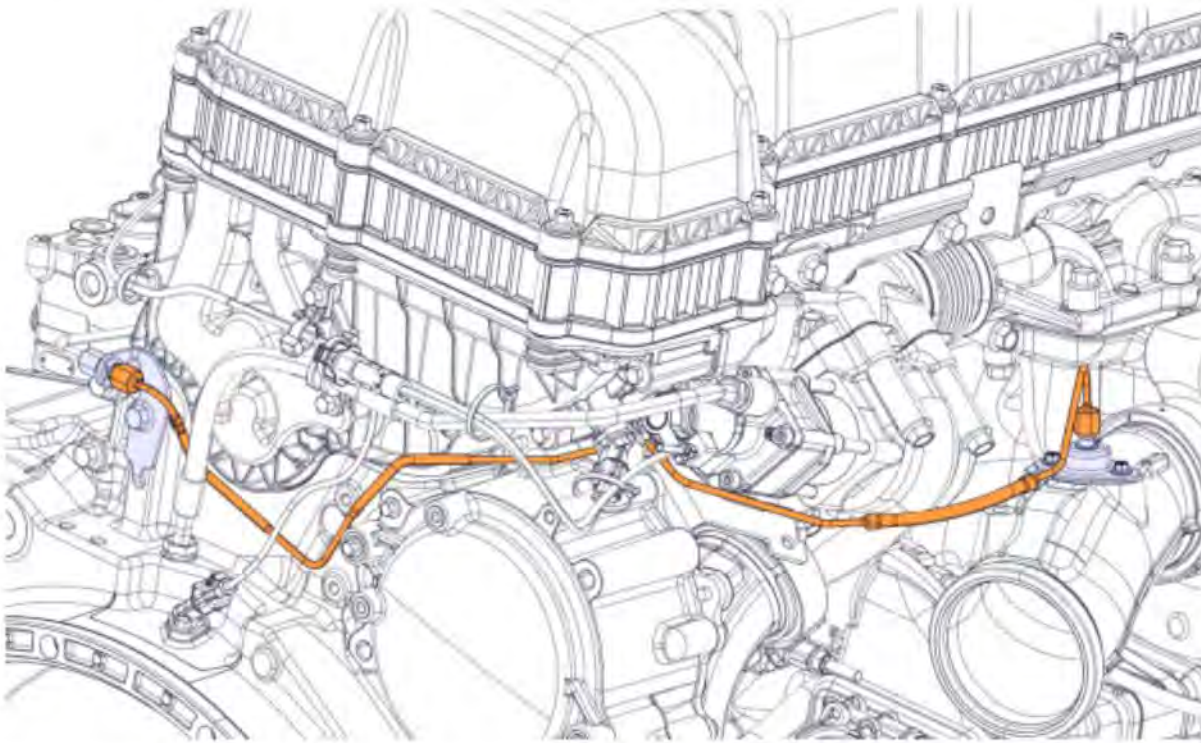

436	<p>Perform this procedure when the condition below is met.</p> <p>Conditions</p> <ul style="list-style-type: none"> • If the pipe is reused, remove a clip. ▶ If there are no clips, replace the pipe. ▶ When installing new pipe, do not remove any clips. <div style="border: 1px solid black; padding: 5px; margin-top: 10px;"> <p>i Note If the pipe has been disconnected on either end for service, this counts as reuse.</p> </div>
------------	--

437	<p>Ensure that the tube is not bent at the crimp.</p> <table border="1" style="width: 100%; border-collapse: collapse;"> <tr> <th colspan="2" style="background-color: #e0e0e0;">Tech data</th> </tr> <tr> <td style="width: 50%;">Fuel pipe, radius (R)</td> <td style="text-align: right;">≥50 mm (≥1.97 in)</td> </tr> </table> <div style="border: 1px solid black; padding: 5px; margin-top: 10px;"> <p>i Note The minimum bend radius is 50 mm at the flexible line.</p> </div> <div style="border: 1px solid black; padding: 5px; margin-top: 10px;"> <p>i Note Do not twist the tube and crimp.</p> </div>	Tech data		Fuel pipe, radius (R)	≥50 mm (≥1.97 in)
Tech data					
Fuel pipe, radius (R)	≥50 mm (≥1.97 in)				

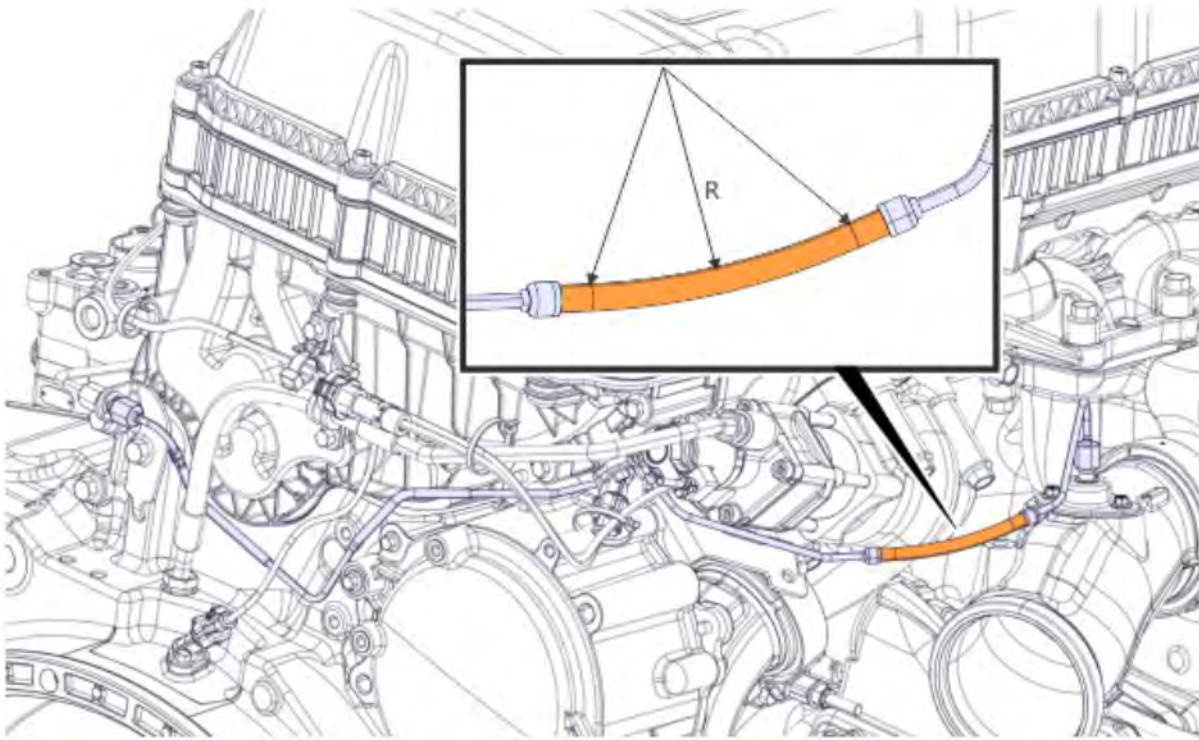

438 Install the nut.

439 Torque tighten the nut.

Tightening torque

Fuel pipe, nut	15 ±2 Nm (11 ±1 lb _f -ft)
----------------	---

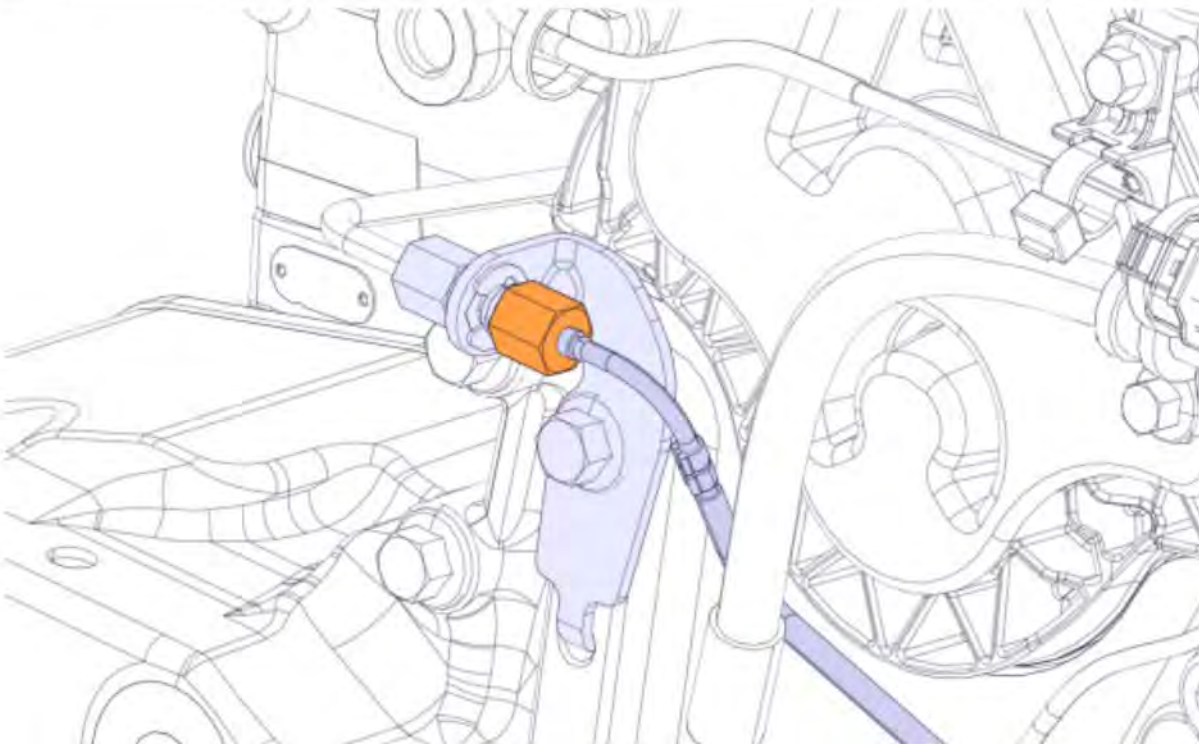

440 Install the nut.

Note

Copyright to this documentation belongs to the Volvo Group. No reproduction, copying, change, amendment or other similar disposal is entitled without prior written consent by the Volvo Group

The information contained herein is current at the time of its original distribution, but is subject to change. The reader is advised that printed copies are uncontrolled.



Hand tighten the nut.

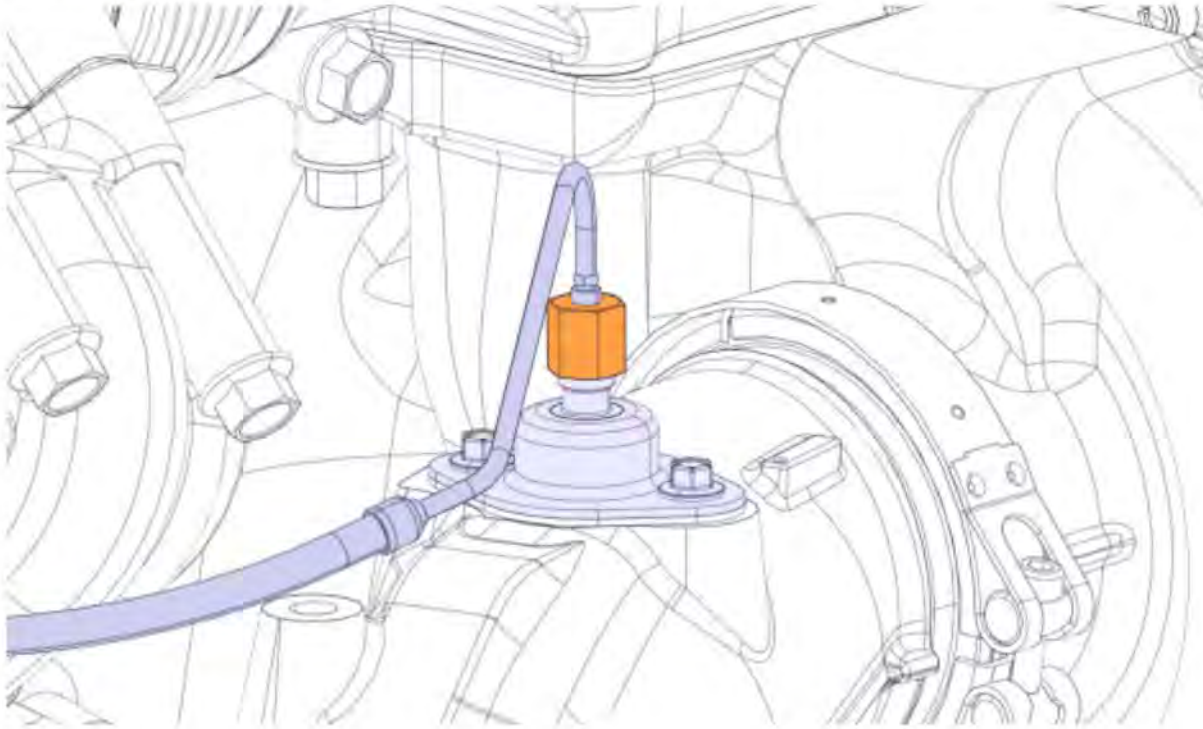

441 Install the clamp along with the screw and nut.

442	Torque tighten the screw.	
	Tightening torque	
	Fuel pipe, screw	24 ±4 Nm (18 ±3 lb _f .ft)

443	Torque tighten the nut.	
	Tightening torque	
	Fuel pipe, nut	24 ±4 Nm (18 ±3 lb _f .ft)

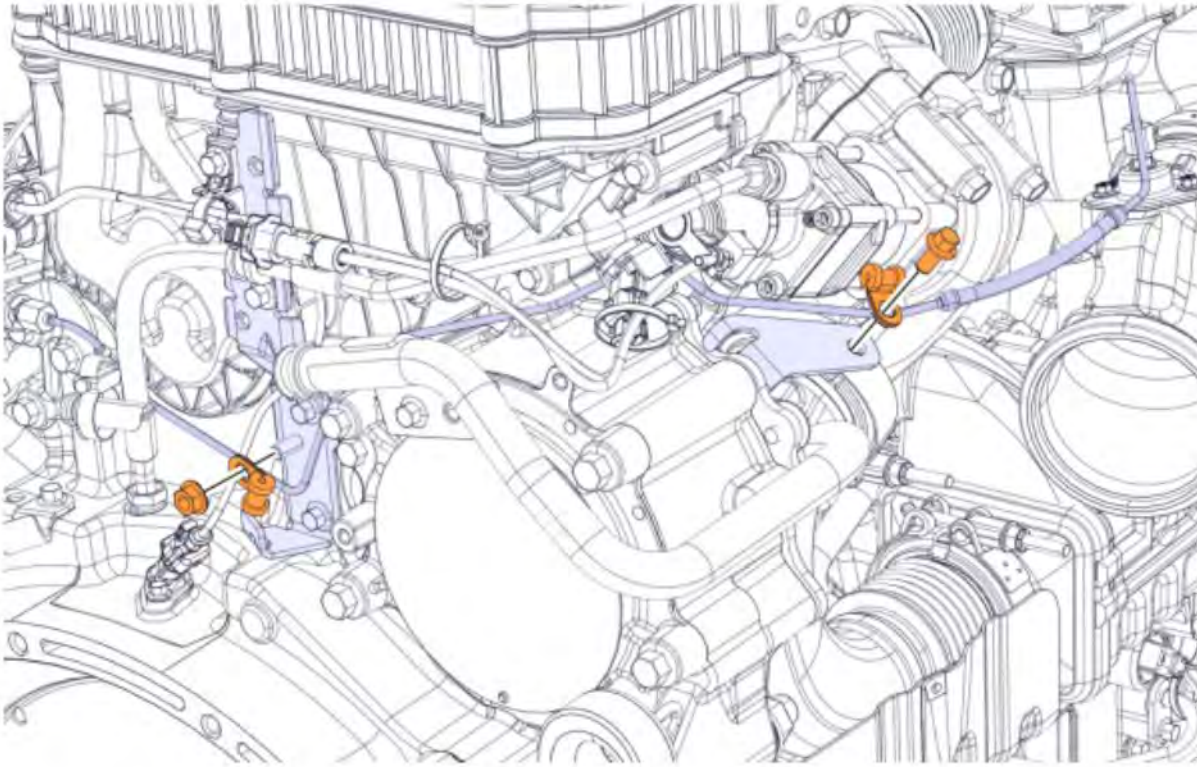

444	Torque tighten the nut.	
	Tightening torque	
	Injector pipe, nut	25 ±6 Nm (18 ±4 lb _f .ft)

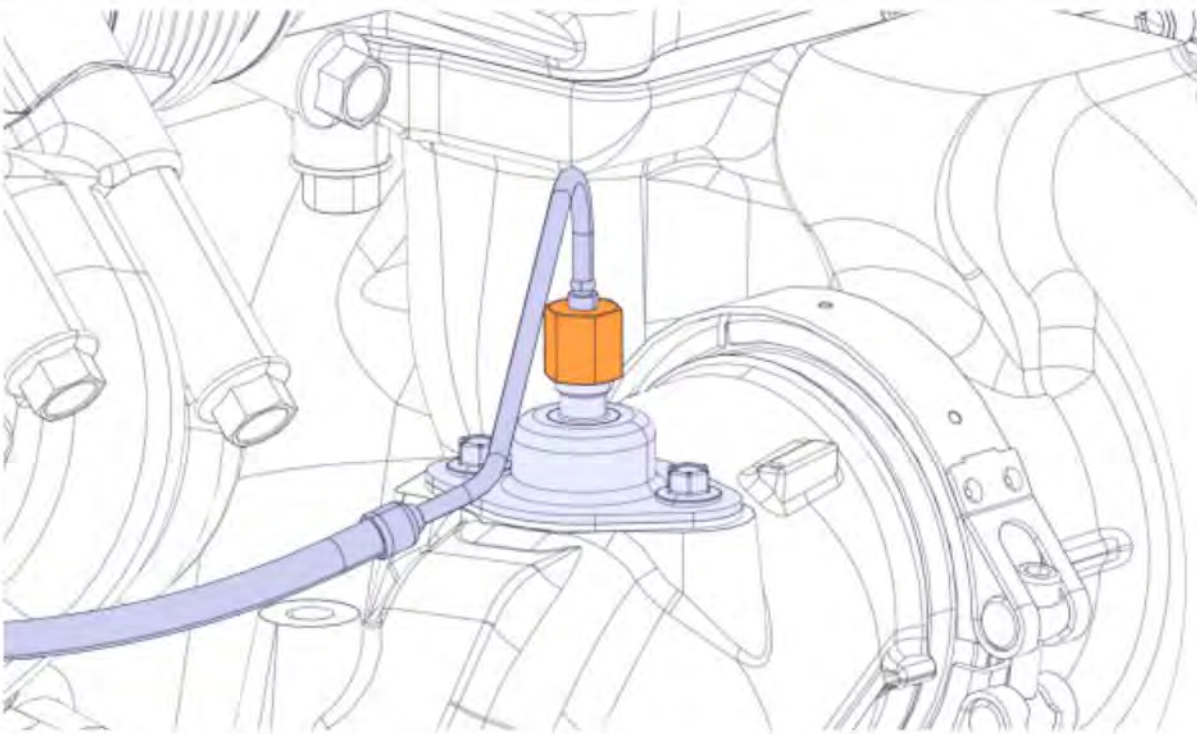

445 Install the seal.

446 Install the pipe.

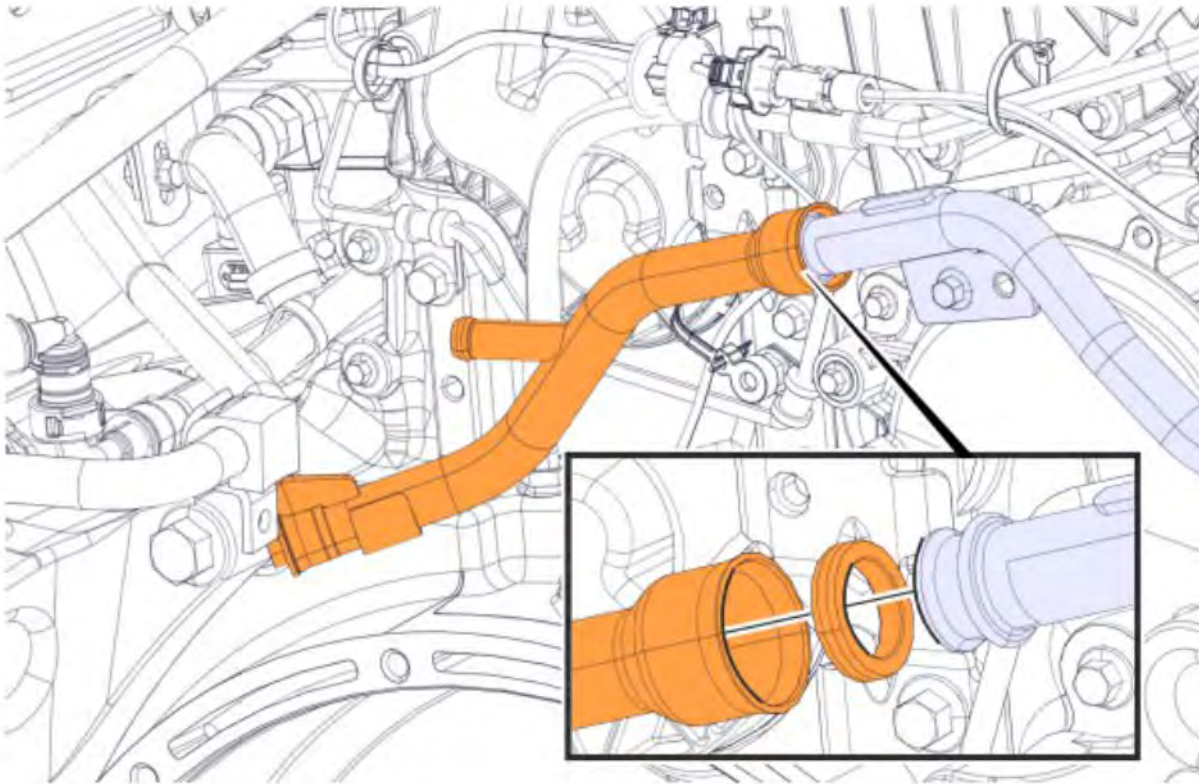

447 Install the clamp.

448 Install the screws.

449 Install the hose.

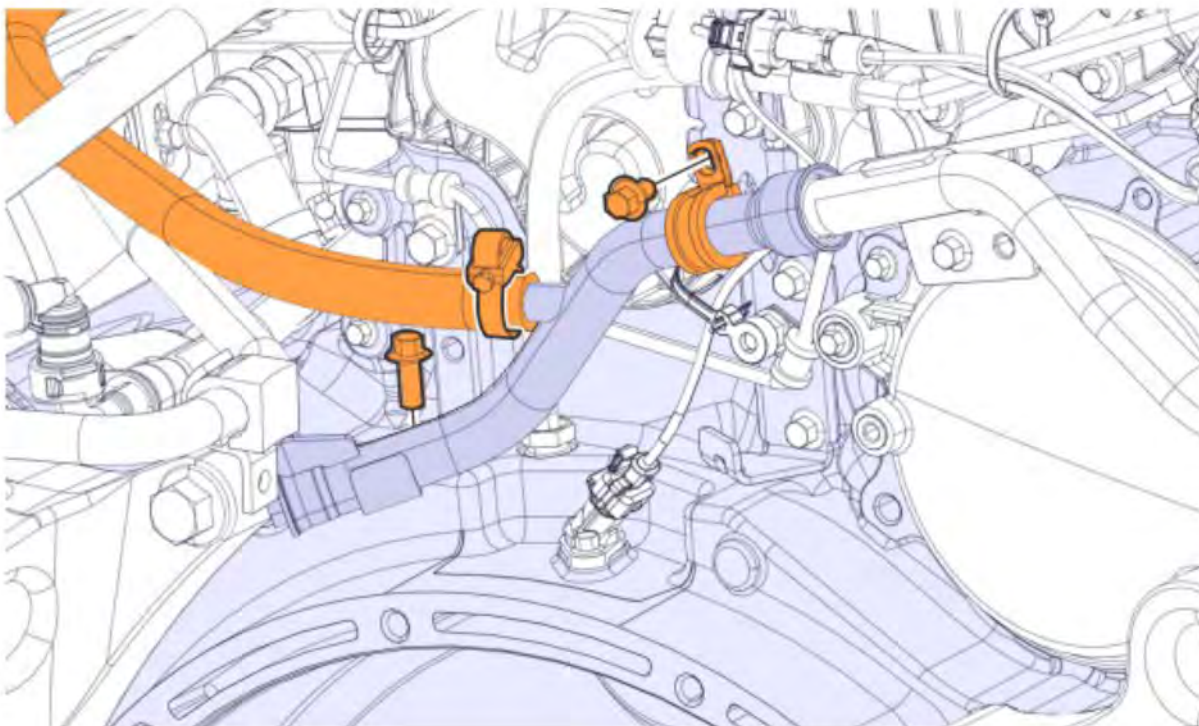

450 Tighten the clamp.

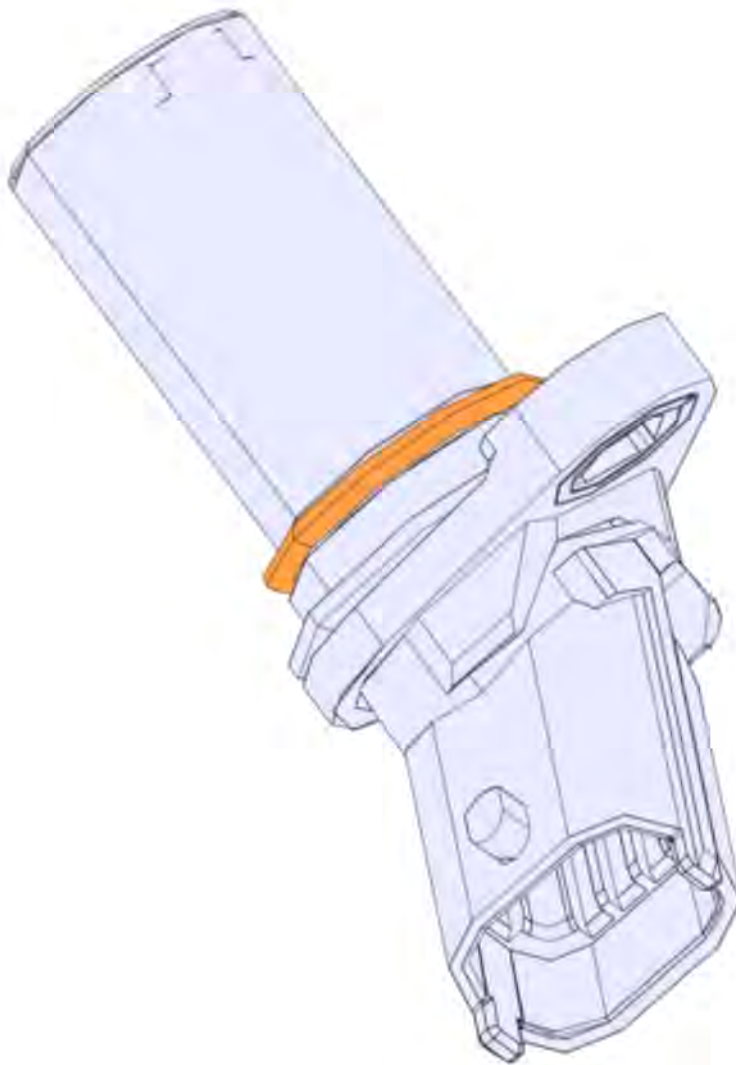

451 Install the o-ring.

Note
Use a new part.



452	Install the sensor (4).		
	<table border="1" style="width: 100%;"> <tr> <td style="width: 10%; text-align: center;"></td> <td>Service hint Install the sensor and shims previously recorded.</td> </tr> </table>		Service hint Install the sensor and shims previously recorded.
	Service hint Install the sensor and shims previously recorded.		

453	Install the heat shield (3).
------------	------------------------------

454	Install the screw (2).
------------	------------------------

455	Tighten the screw to torque.		
	Tightening torque		
	<table border="1" style="width: 100%;"> <tr> <td style="width: 50%;">Camshaft speed sensor, screw</td> <td style="text-align: center;">8 ±2 Nm (6 ±1 lb_f-ft)</td> </tr> </table>	Camshaft speed sensor, screw	8 ±2 Nm (6 ±1 lb _f -ft)
Camshaft speed sensor, screw	8 ±2 Nm (6 ±1 lb _f -ft)		

456	Connect the connector (1).
------------	----------------------------

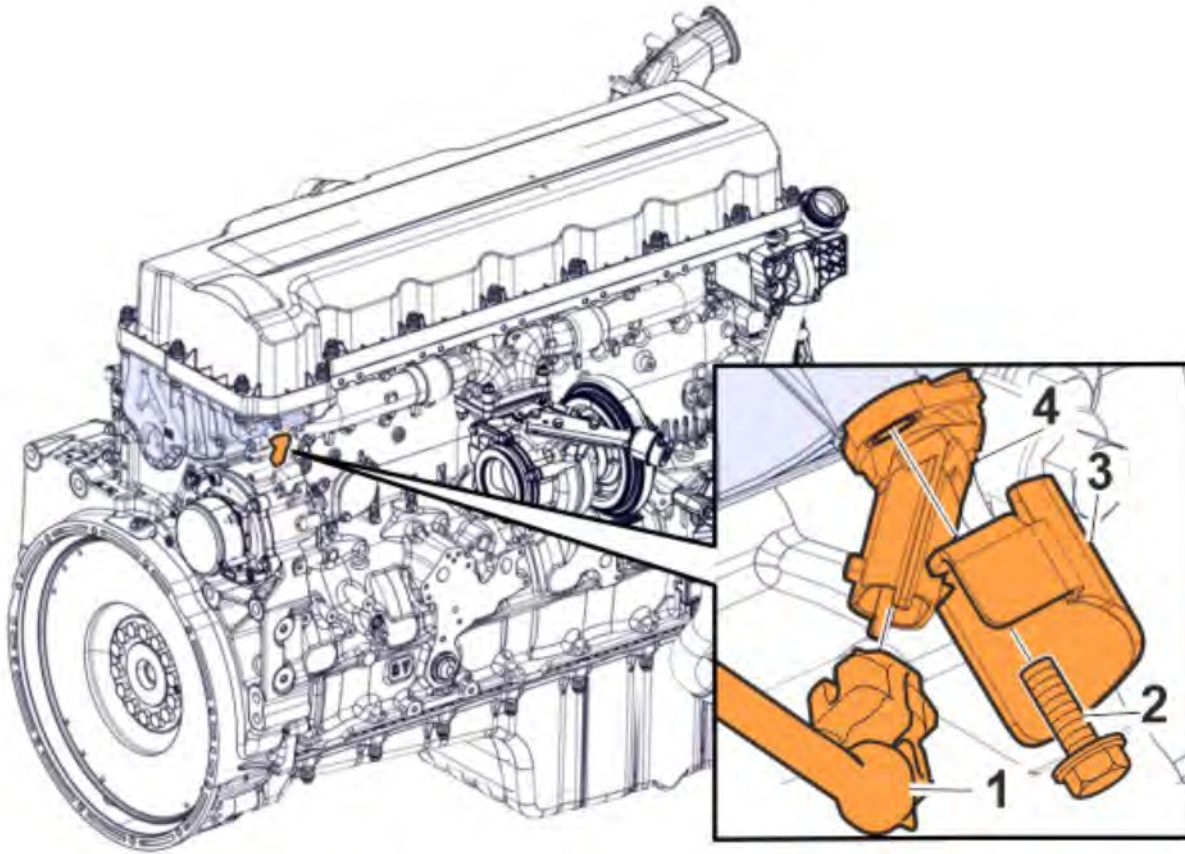

457	Install the o-ring.				
	<table border="1" style="border-collapse: collapse;"> <tr> <td style="text-align: center; width: 20px;">i</td> <td style="padding: 2px;">Note</td> </tr> <tr> <td colspan="2" style="padding: 2px;">Use a new part.</td> </tr> </table>	i	Note	Use a new part.	
i	Note				
Use a new part.					

458	Install the sensor.
------------	---------------------

459	Install the screw.
------------	--------------------

460	Tighten the screw to torque.
Tightening torque	
Camshaft speed sensor, screw	$8 \pm 2 \text{ Nm}$ $(6 \pm 1 \text{ lb}_f\text{-ft})$

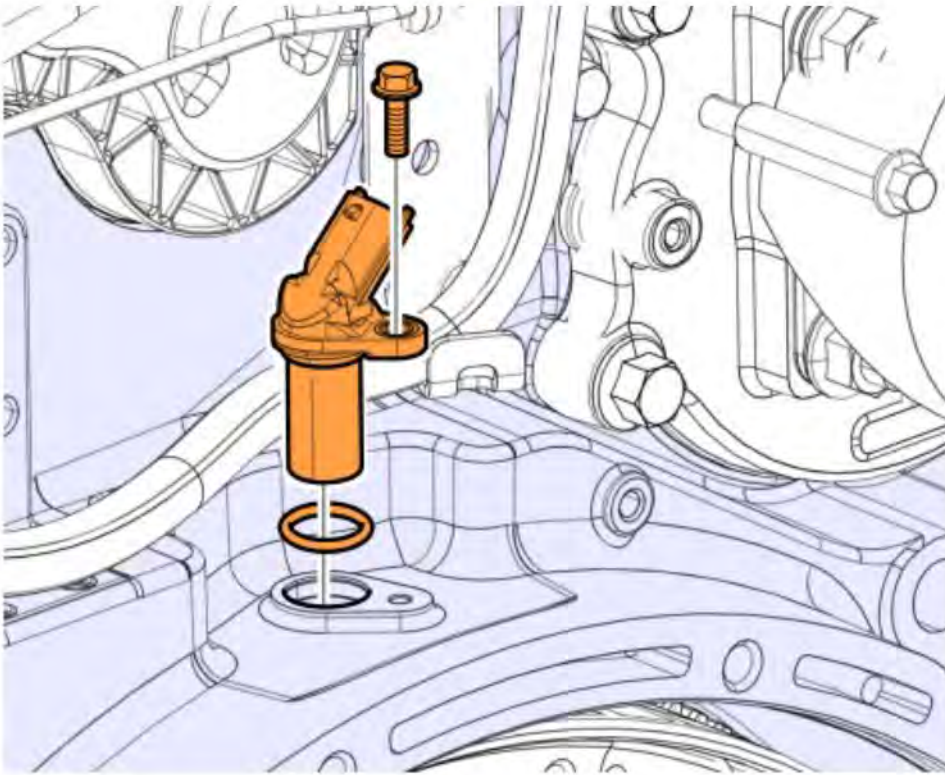

461 | Connect the connector.

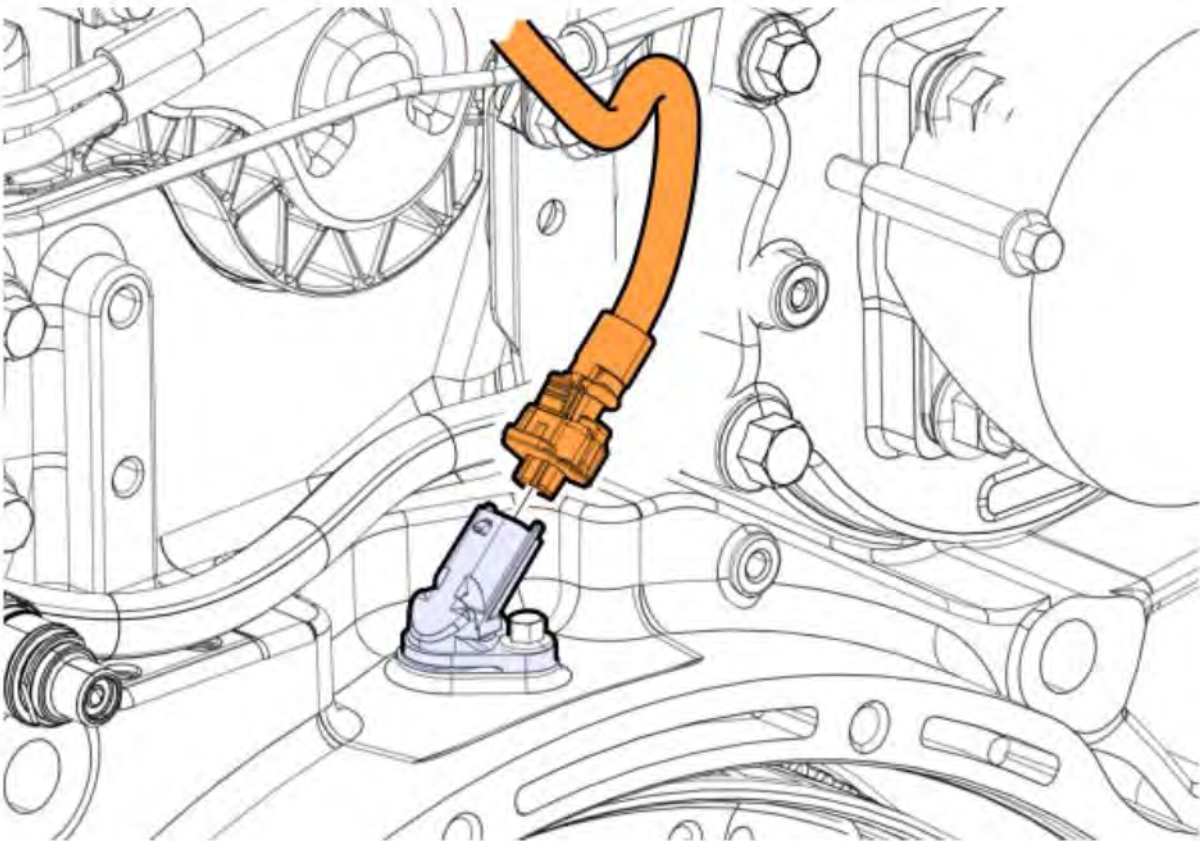

462 | Install the duct.

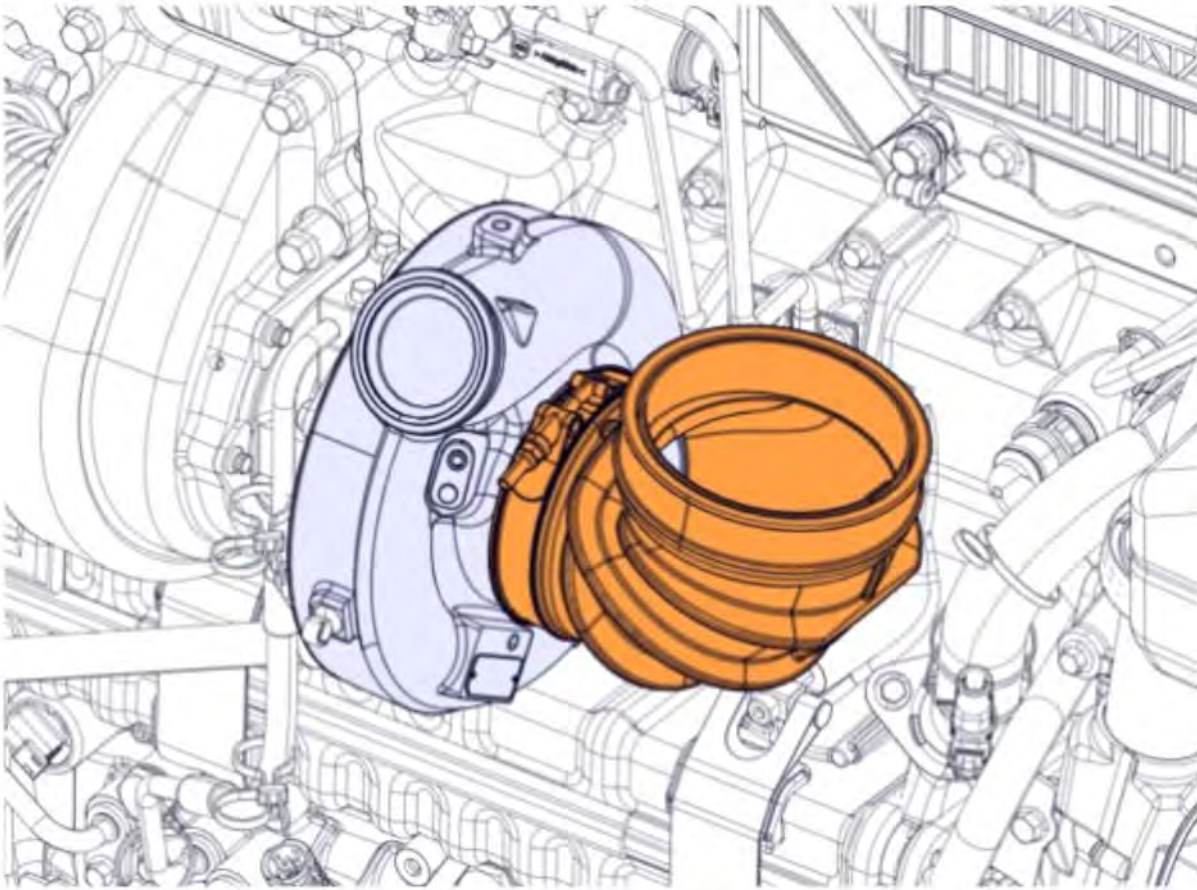

463	Torque-tighten the clamp.	
	Tightening torque	
	Air duct, clamp	$9 \pm 1 \text{ Nm}$ $(80 \pm 9 \text{ lb}_f\text{-in})$

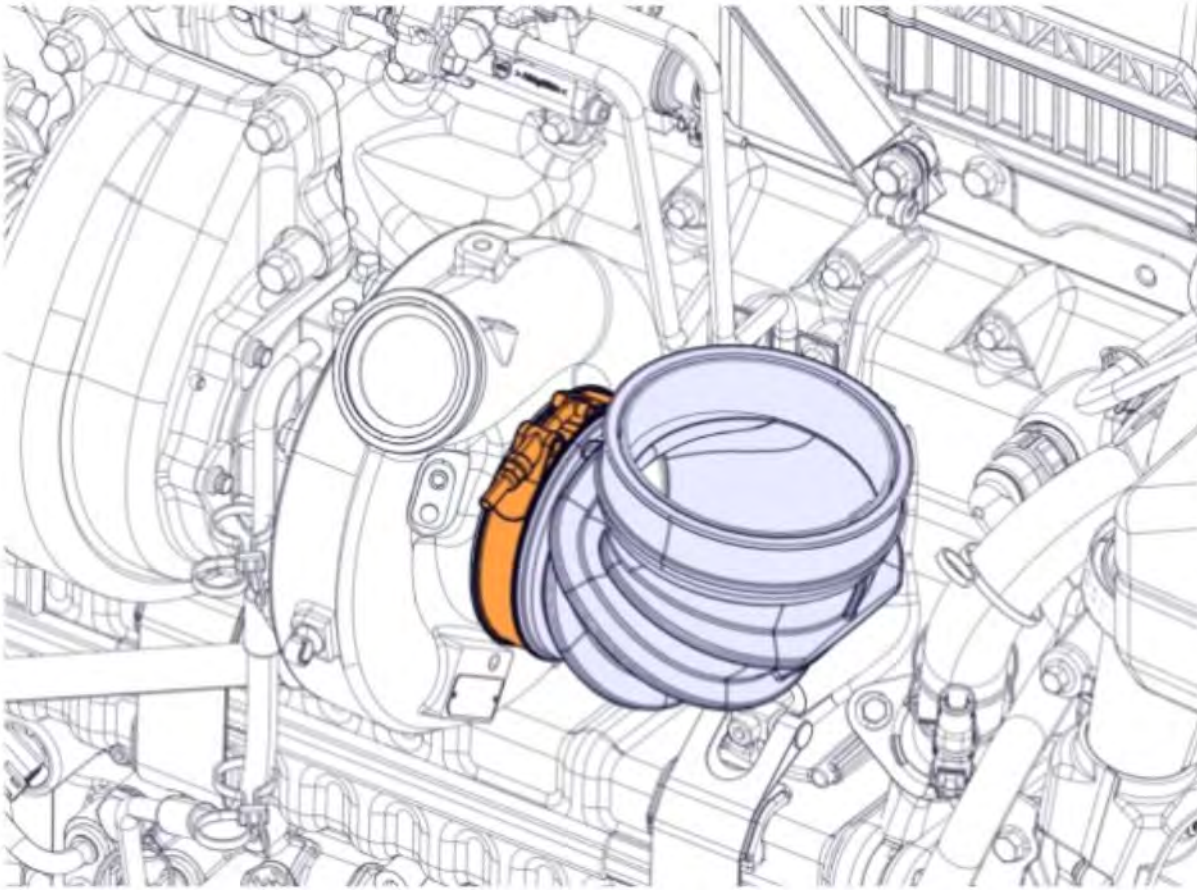

464 Install the air filter housing.

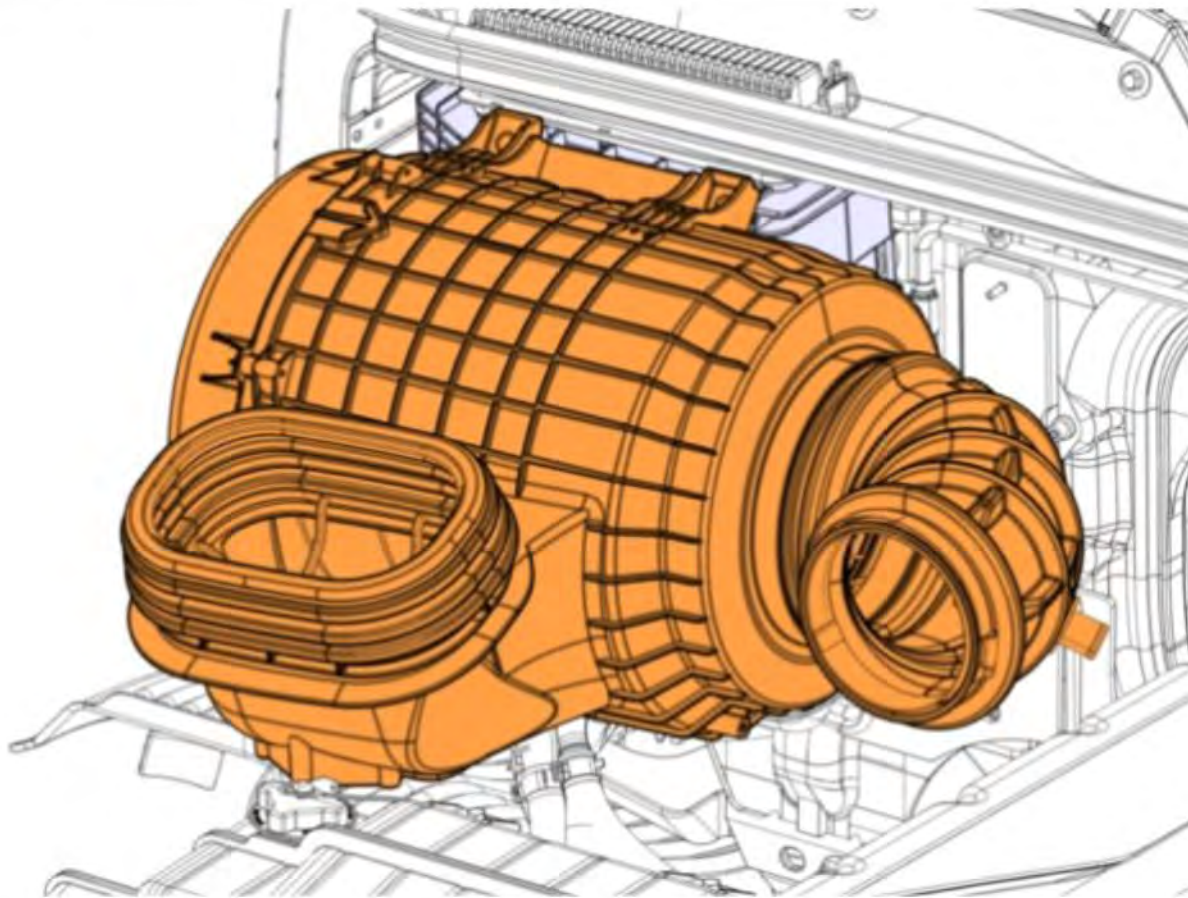

465 Install the screws.

Copyright to this documentation belongs to the Volvo Group. No reproduction, copying, change, amendment or other similar disposal is entitled without prior written consent by the Volvo Group

The information contained herein is current at the time of its original distribution, but is subject to change. The reader is advised that printed copies are uncontrolled.

466	Torque tighten the screws.	
Tightening torque		
Screw	M10	
	48 ±8 Nm	
	(35 ±6 lb _f .ft)	

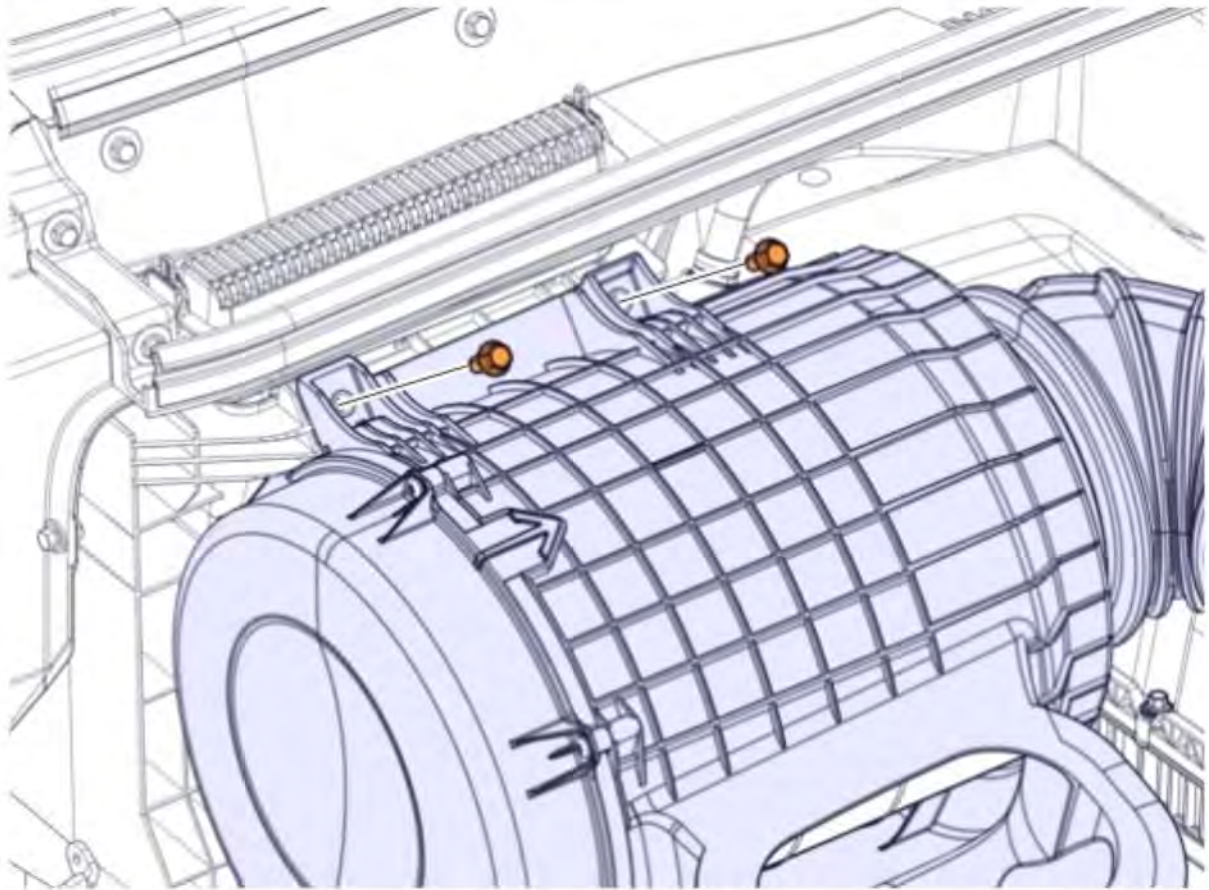

467	Install the air duct.	
-----	-----------------------	--

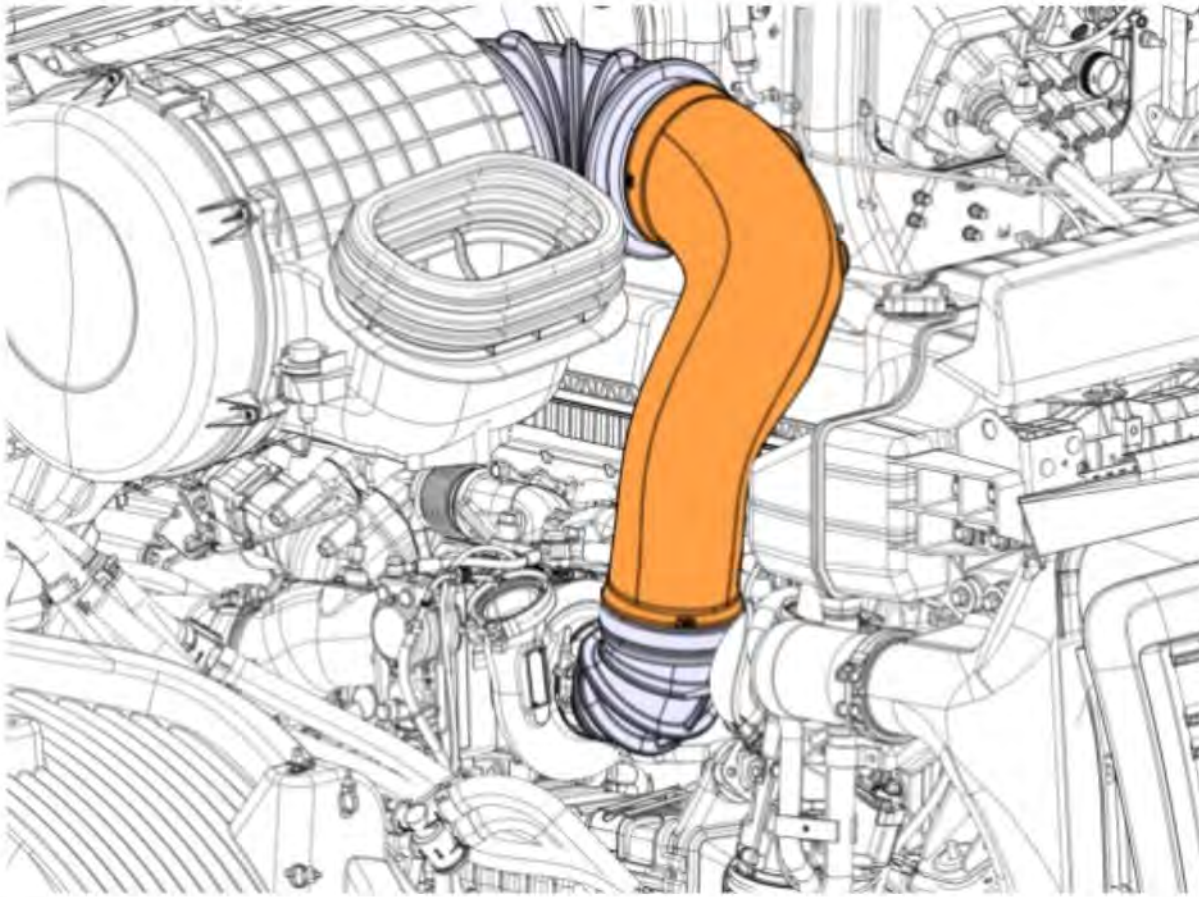

468	Torque tighten the clamps.	
	Tightening torque	
	Air duct, clamp	$9 \pm 1 \text{ Nm}$ $(80 \pm 9 \text{ lb}_f \cdot \text{in})$
	<div style="border: 1px solid black; padding: 2px; display: inline-block;">  </div>	Note As noted.

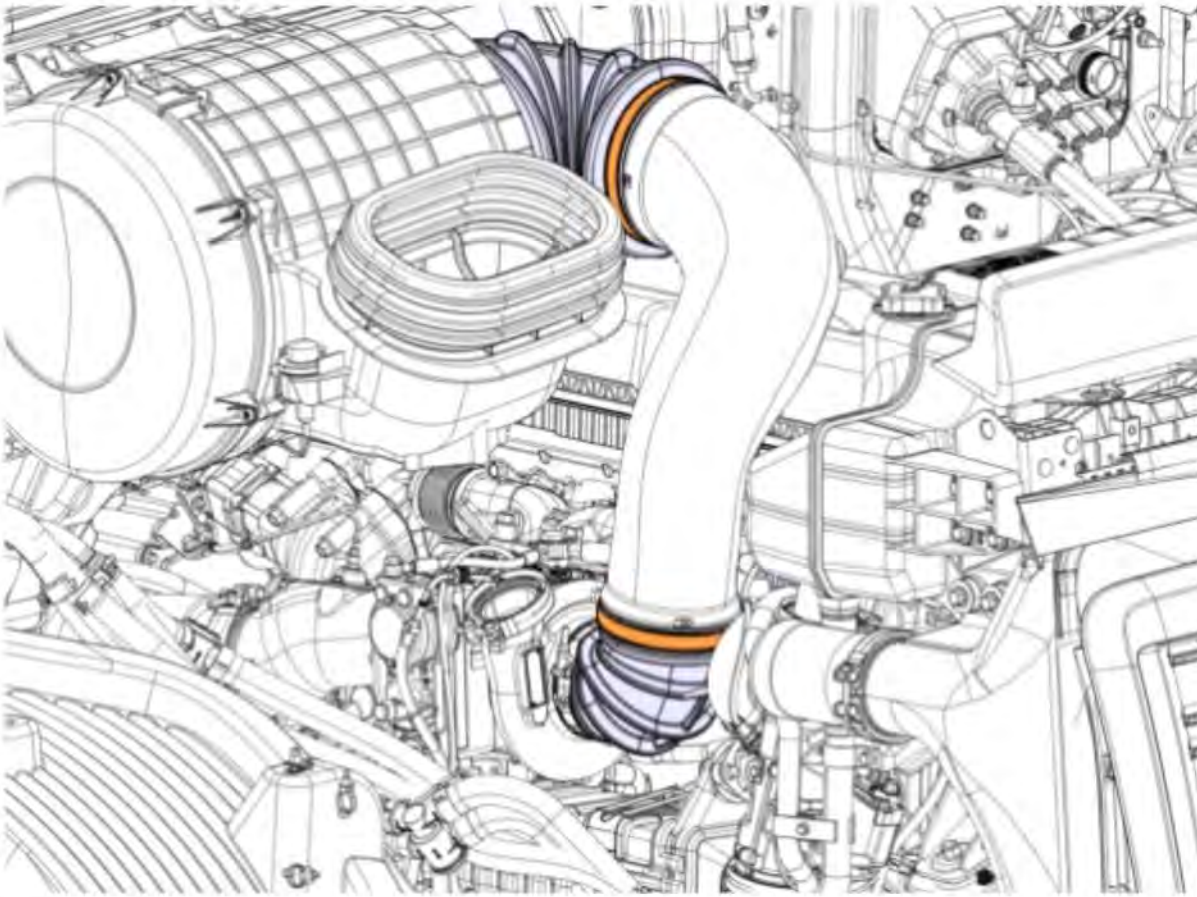

469 Install the seals.



Note

Inspect the seals, replace as needed.

470 Install the charge air pipe.

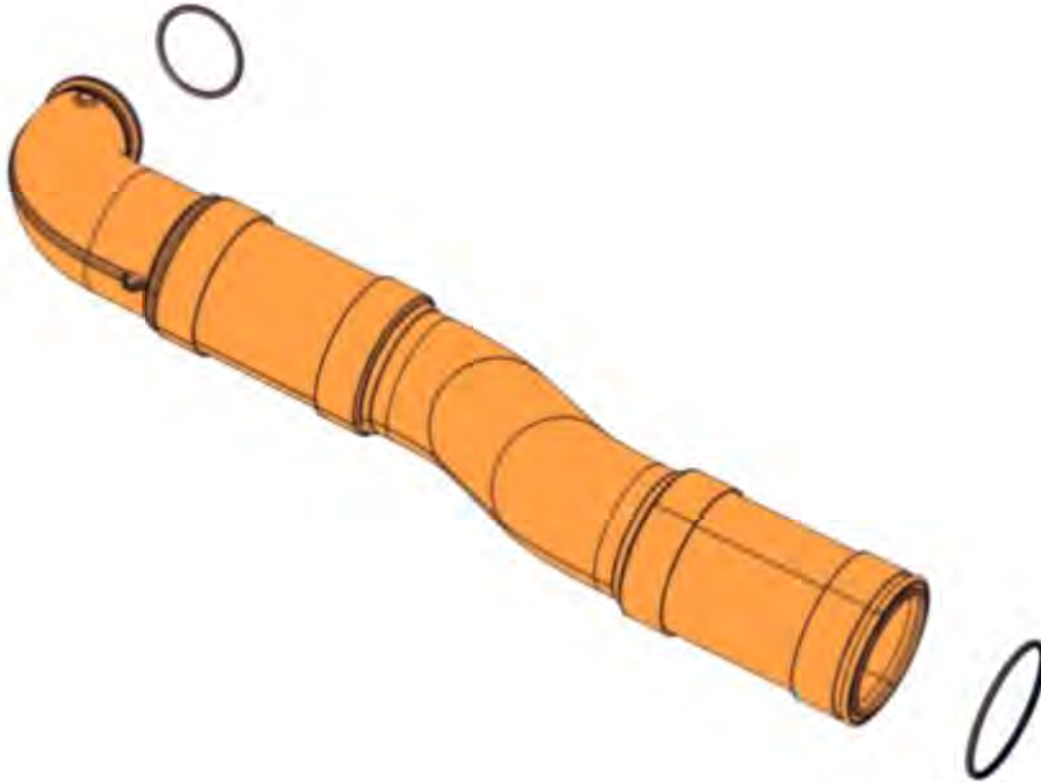

471	Install the V-clamps.		
	<table border="1" style="border-collapse: collapse;"> <tr> <td style="text-align: center; width: 20px;">i</td> <td>Note Note the orientation.</td> </tr> </table>	i	Note Note the orientation.
i	Note Note the orientation.		

472	Tighten the V-clamps to torque.	
	Tightening torque	
	V-clamp, screw	$7 \pm 1 \text{ Nm}$ $(5 \pm 1 \text{ lb}_f\text{-ft})$

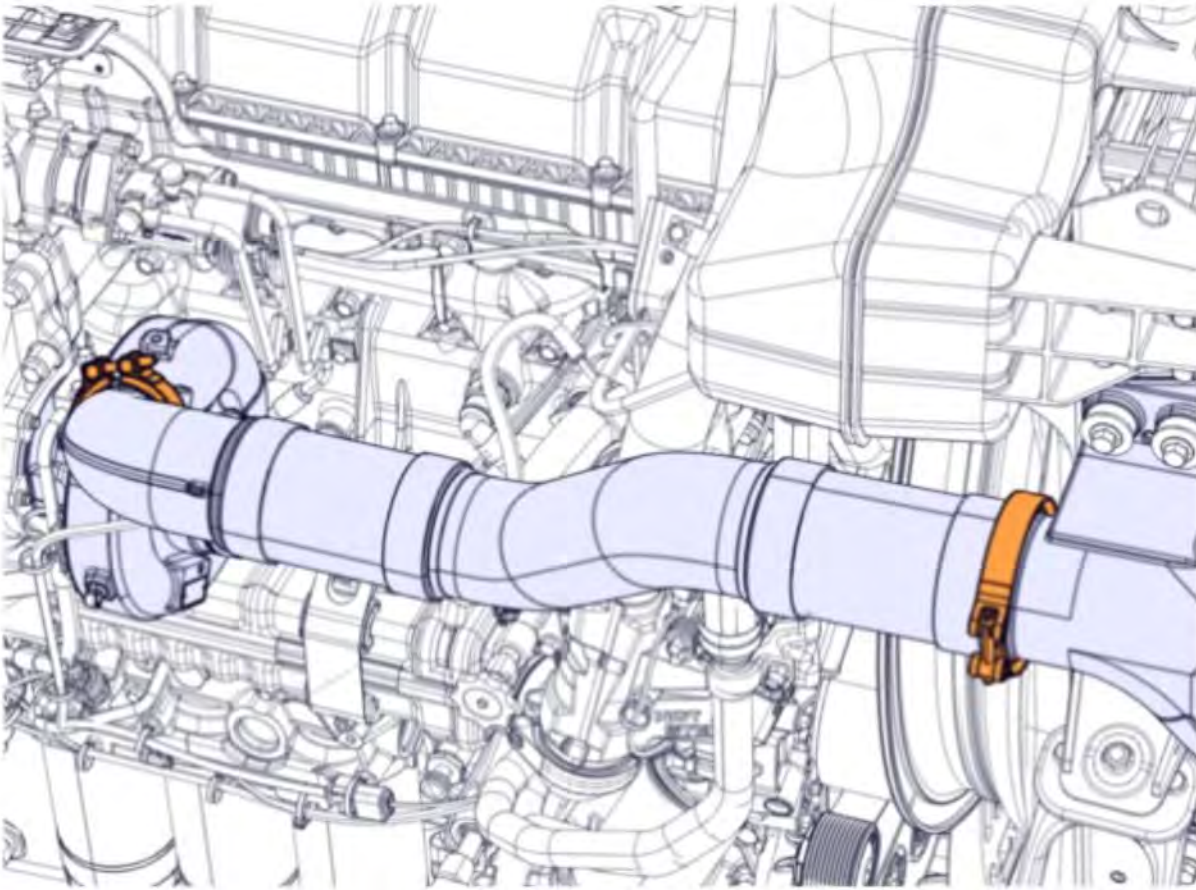

473 Install the hose.

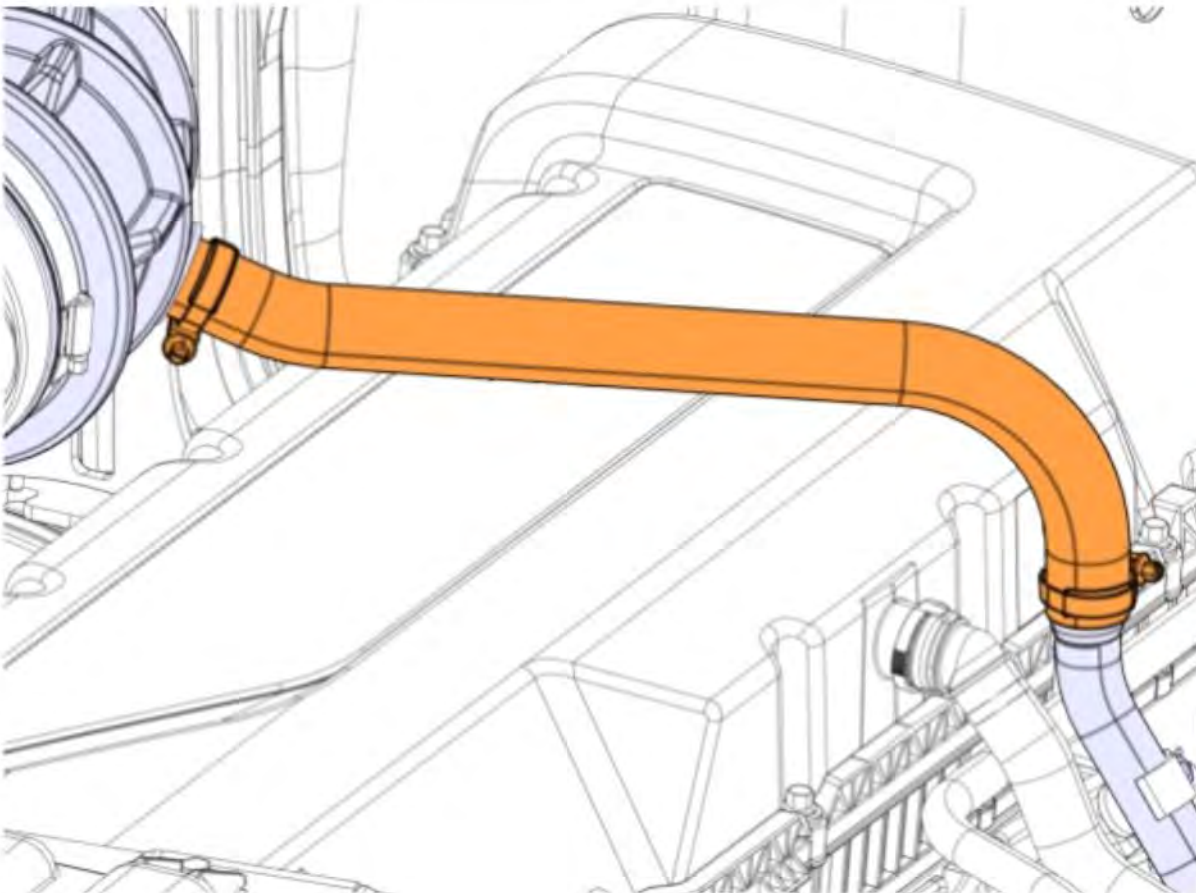

474 Position the clamps.

Copyright to this documentation belongs to the Volvo Group. No reproduction, copying, change, amendment or other similar disposal is entitled without prior written consent by the Volvo Group

The information contained herein is current at the time of its original distribution, but is subject to change. The reader is advised that printed copies are uncontrolled.



Note
As noted.

475 Tighten the clamps to torque.

Tightening torque

Clamp, screw	3.95 ±0.6 Nm (35.0 ±5 lb _f ·in)
--------------	---

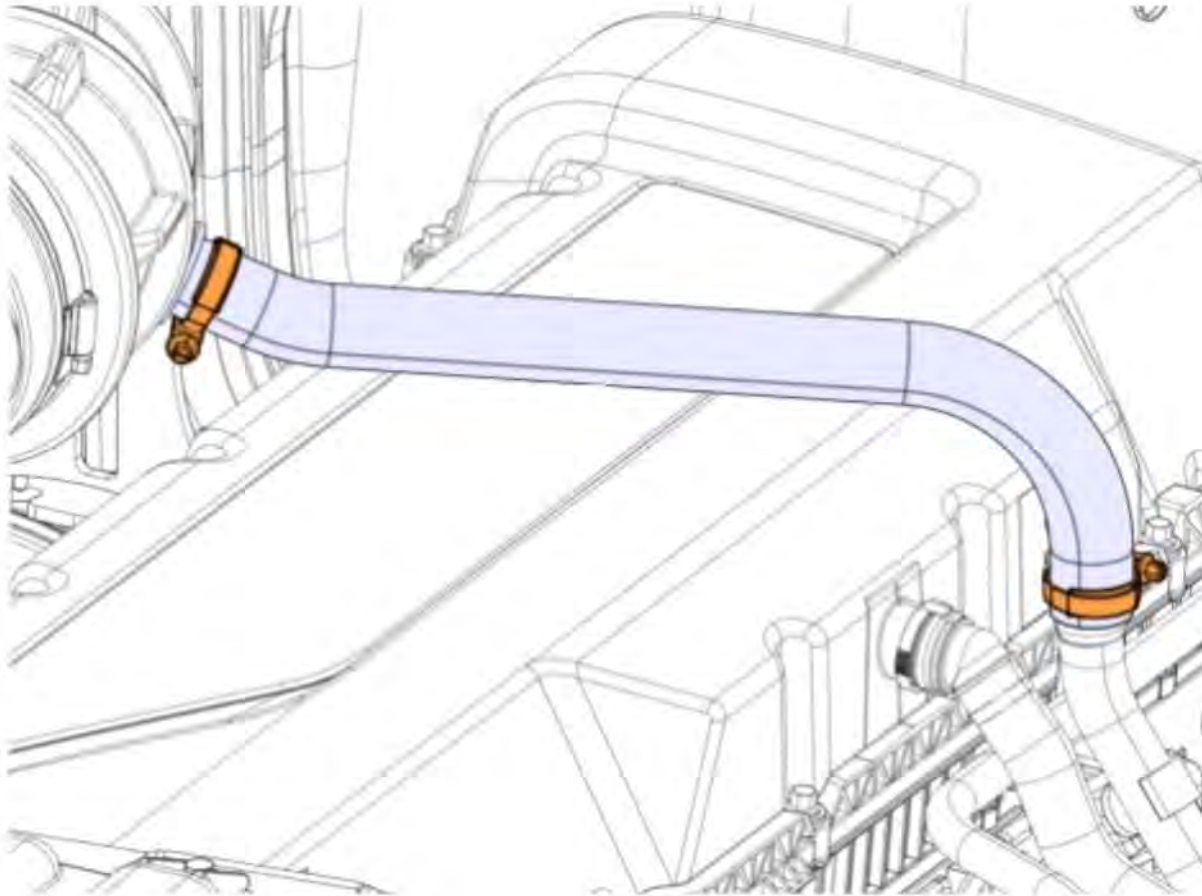

476 Lower the vehicle.

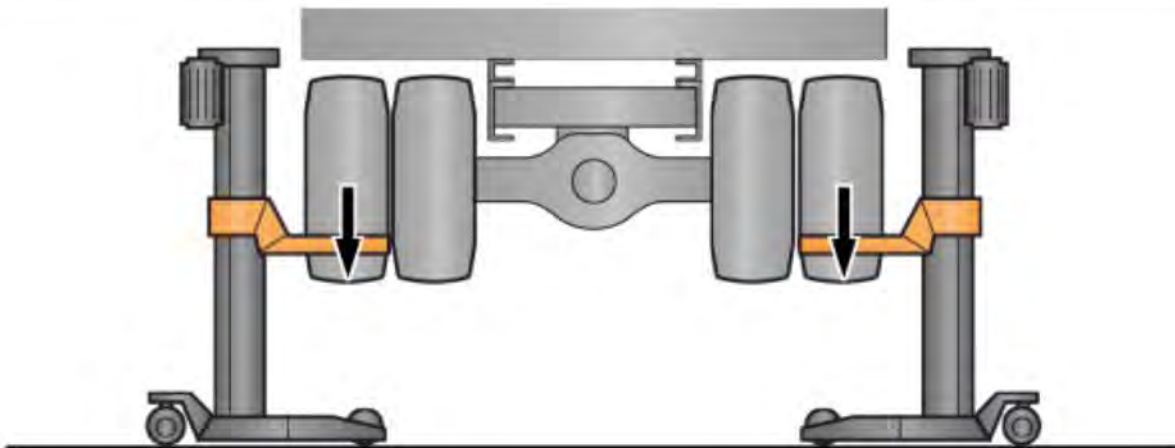

477 Remove the column lifts.

Copyright to this documentation belongs to the Volvo Group. No reproduction, copying, change, amendment or other similar disposal is entitled without prior written consent by the Volvo Group

The information contained herein is current at the time of its original distribution, but is subject to change. The reader is advised that printed copies are uncontrolled.

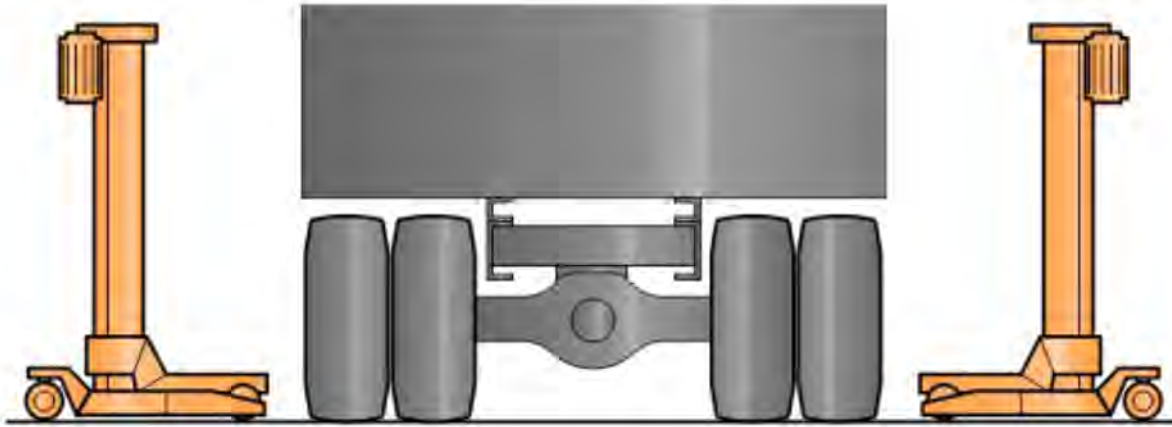

478 Perform this procedure when the condition below is met.

Conditions

- If all of the coolant connections have been made, fill the coolant system.

► Fill the cooling system.



Note

Use approved coolant.

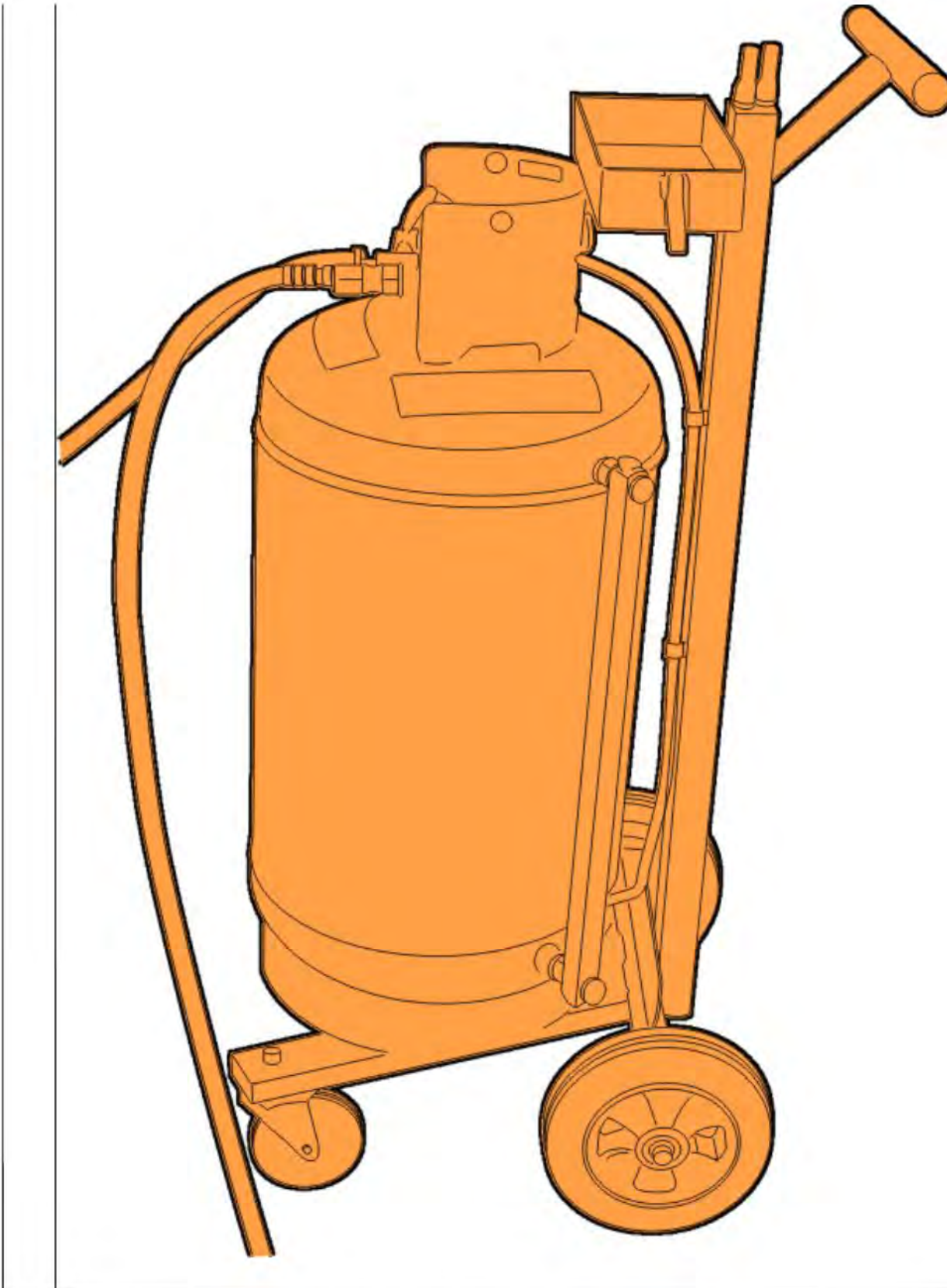

479	Perform this procedure when the condition below is met.
	Conditions
	<ul style="list-style-type: none"> • If the end cap is removed
	<ul style="list-style-type: none"> ▶ Install the end cap.

480 Fill with engine oil.

Copyright to this documentation belongs to the Volvo Group. No reproduction, copying, change, amendment or other similar disposal is entitled without prior written consent by the Volvo Group

The information contained herein is current at the time of its original distribution, but is subject to change. The reader is advised that printed copies are uncontrolled.

i	Note Use recommended oil.
----------	-------------------------------------

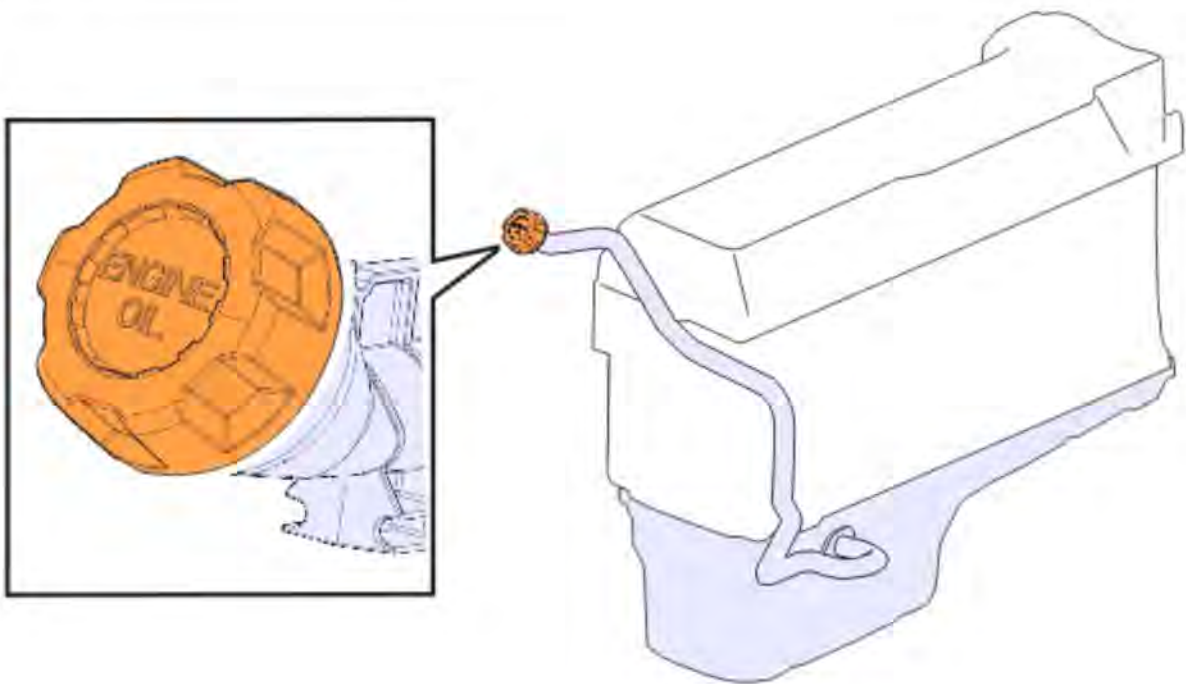

481	Perform this procedure when the condition below is met.
	Conditions
	<ul style="list-style-type: none"> • If the engine cover was removed for service
	<ul style="list-style-type: none"> ▶ Install the engine cover.

482	Install the lower left side splash shield.
------------	--

483	Install the lower right side splash shield.
------------	---

484	Lower the hood.
i	Note Ensure that the hood is latched.

Timing Gear Plate, Integrated Plate
Job Aid

Special
Tools

Coolant Extractor 85112740



Drain Hose 9996049



Disassembly Tool J-44773



Cranking Tool 88840317



Fixture 88800570



Impact Wrench 9996400



Puller 9990192



Disassembly Tool 88800502



Guide 9998267



Rocker Indicator 9999683



Magnetic Stand 9999696



Timing Kit J-44514B



Assembly Tool 88800619



Assembly Tool 9990166



Align Tool 85111422



Setting Tool 8880031



Align tool 9990024



Fixture 9996857



Transmission jack and plate



TC Support Plate 88800826



<ol style="list-style-type: none"> 1) Secure the truck for service, disconnect negative cable. 2) Drain air and coolant. 3) Remove interior components. 4) Remove transmission. 5) Remove air cleaner box, CAC pipe and Diffuser pipe 6) Remove EGR valve, EGR crossover pipe, valve cover, spacer frame, and upper timing cover. 7) Remove all electrical, coolant lines, air lines, and brackets from the rear of the engine. 8) Remove air compressor, starter, and tandem pump. 	<div style="border: 1px solid black; padding: 5px; background-color: #e0e0e0;"> <p>Teardown 0-4 Hrs.</p> </div>	<ol style="list-style-type: none"> 9) Remove oil pan and Remove oil filters. 10) Place the engine on TDC. 11) Raise and support the engine and Remove engine mounting brackets from flywheel housing. 12) Remove engine mounts from the frame. 13) Remove clutch, pressure plate, and flywheel. 14) Install TC support tool. (TC engine Only) 15) Remove all hardware securing the flywheel housing and remove the flywheel housing. 16) Remove timing gears <ul style="list-style-type: none"> • Tandem idler rear (a puller may be required to remove the gear) • TC Idler Gear (TC Engine Only) • Cam gear, Double idler gear and Adjustable idler gear 17) Install aligning dowels, removed TGP hardware, and remove TGP. 	<div style="border: 1px solid black; padding: 5px; background-color: #e0e0e0;"> <p>Teardown 5-8 Hrs.</p> </div>
<ol style="list-style-type: none"> 18) Apply seal conditioner to the block and head. 19) Install TGP and new mounting bolts. 20) Install all timing gears verifying timing and gear lash are correct. 21) Make sure to remove alignment dowels. 22) Apply seal conditioner to the TGP. 23) Install flywheel housing and torque all securing hardware to spec. 24) Remove TC support tool. (TC Engine Only) 25) Install engine mounting bracket to flywheel housing and engine mounts in frame. 26) Lower engine onto the engine mounts, install and torque engine mounting bolts. 27) Clean and install oil pan, hook up level sensor, dipstick, and fill tube. 28) Replace oil filters and fill engine with new oil. 29) Install rear main seal, flywheel, and starter 30) Install upper timing cover, valve cover, and EGR cross over pipe. 31) Install tandem pump, air compressor, all compressor line and connection. 32) Connect EI (engine interface) connector. 	<div style="border: 1px solid black; padding: 5px; background-color: #e0e0e0;"> <p>Install 9-13 Hrs.</p> </div>	<ol style="list-style-type: none"> 33) Install all electrical, coolant lines, air lines, and brackets from the rear of the engine. 34) Install EGR valve, EGR hot pipe, diffuser pipe, flex pipe, and install hot side CAC pipe. 35) Install air cleaner housing and turbo inlet pipe. 36) Install clutch and pressure plate. 37) Ready transmission for installation and install trans. 38) Route and secure battery cables, trans cooler coolant lines, air lines, and electrical harness. 39) Install drive line. 40) Fill engine with coolant. 41) Connect batteries, Start engine and check for leaks. 	<div style="border: 1px solid black; padding: 5px; background-color: #e0e0e0;"> <p>Install 14-17.8 Hrs.</p> </div>
Training Video available at Volvo Trainings Support.com		Additional Communications	
Turbo Compound Support Bracket		TSB M-212-003 Timing gear plate, Inspection/Repair	
Timing Gear Plate Install		Repair operation 2152-03-03-05 (Timing Gear Plate, Replacement) in Impact	
Frame Mounted Engine Support Install		CBR-2260 Timing Gear Plate Repair	



Special Tools Bulletin

To: Service Managers
Parts Managers
Technicians

Region: U.S.
 CAN

Bulletin:
Date: December 21, 2022
Valid to: December 31, 2023
Action Required? Yes No

From: Tyler Griffin – Proprietary Systems & Components Specialist.
Subject: Volvo Essential Tool Shipment

The tools listed below will be shipped **automatically** to all Volvo dealers (full-line, parts & service, and satellite locations) from the PDC. Each dealer will be invoiced on **ET1201V**. **This tool is used to hold the Turbo Compound in place while performing Timing Gear Plate repairs. Repair instructions and videos are below.**

Part Number	Description	Quantity
88800826	13 L Turbo Compound Support Bracket	1

Please advise your parts department staff to expect these Essential Tools for the Service Department.

You may order additional Essential Tools; pricing is available on the Parts System.

Contact Information

If you have questions, please contact your Technical Service Manager.

Essential Special Tool
88800826

Turbo Compound Support – *while performing TGP (Timing Gear Plate) oil leak repairs*





Instructions:

1. Remove the starter.
2. Remove the Turbo Compound oil feed line.
3. Remove the EGR heat shield.
4. Remove top V-band clamp for the EGR cooler's hot pipe.
5. Remove bottom V-band clamp for the EGR cooler's hot pipe.
6. Remove the EGR cooler's hot pipe.
 - A. Make sure to remove the EGR cooler rear seal.
7. Disconnect and set aside the following line sets:
 - A. Aftertreatment Hydrocarbon Injector
 - B. Exhaust gas pressure line
 - C. Engine brake
 - D. Turbo compound buffer supply
8. – Unplug camshaft sensor harness.
9. – **IMPORTANT:** There is a key fastener/bolt that threads in the timing gear plate. This fastener/bolt is hidden and must be removed prior to installing the Turbo compound tool.
10. – Here you see the Turbo compound tool and its mounting hardware.
 - A. 2-3 fasteners depending on EM level.
11. – First you will remove the 2-exhaust heat shield mounting bolts, and Turbo Compound lifting eye bolt.
 - A. 2-3 fasteners depending on EM level.
12. – Next secure the Turbo Compound tool bracket to the cylinder head, utilizing the bolt holes from the previously removed exhaust heat shield bolts.
13. – At this point you will need to prep the threaded rod with one of the nuts from the hardware kit. You will thread one of the nuts about $\frac{1}{4}$ of the way up on the threaded rod.
14. – Securing the Turbo Compound tool mounting bracket to the Turbo Compound housing.
 - A. Slide the supplied threaded rod through the slotted hole in the Turbo Compound tool mounting bracket.
 - B. Thread the rod in the bolt hole from the previously removed Turbo Compound lifting eye bolt, thread the rod until it bottoms out.
 - C. Secure the rod to the Turbo Compound housing by running the previously installed nut flush with the housing, and slightly tighten.
 - D. Install the second nut above on the threaded rod above the Turbo Compound tool mounting bracket. Thread nut down flush with the mounting bracket and slightly tighten.
- 15– Tool Removal:
 - A. Loosen both nuts on the threaded rod.
 - B. Unthread rod from the Turbo Compound lifting eye bolt hole. You do not have to fully remove the threaded rod from the mounting bracket.
 - C. Remove both Turbo Compound tool mounting bracket bolts at cylinder head.

VOLVO TRUCKS UPTIME



Please see attached training video that can also be found in TDP under training videos.

[TC Bracket Volvo 1 - YouTube](#)

Warranty Operations Manual

Canada, United States, Latin America

Put your search topic here...



N

Index

◀Back

- TIMING GEAR PLATE - Clean Claim Template



Warranty Approval

The timing gear plate follows the major component coverage.

Resources & References

For further information on timing gear plate repairs & documentation, please reference the following in IMPACT and/or CBR:

- Technical Service Bulletin 212-003 - Timing Gear Plate, Inspection
- Detailed repair procedure instructions - 2152-03-03-05 Timing Gear Plate, Replacement

Claim Filing Instructions

- Claim Type: Vehicle Warranty
- Main Labor Operations:
 - 2152-03-02-04 Timing Gear Plate, Replacement
 - Note: SRT includes labor for R/R of the transmission, clutch, flywheel, flywheel housing, etc.
 - 1700-16-03-01 Diagnostic Time
 - Standard Diagnostic Time for this repair is 2 hours.
- Causal Part:
 - Use applicable causal part from Impact referencing the VIN and Function Group 215 – Timing Gears
- Remarks Tab:
 - Fill in the complaint, cause and correction sections describing the details of the failure.
- Attachments Tab:
 - Warranty requires 3 pictures be attached to the claim
 - See attachment - Timing Gear Plate for examples

Exclusions & Limitations

Failure to attach quality pictures to the claim that clearly illustrate the issue may result in claim denial.

Warranty will only cover timing gear plate claims on active leaks. To verify if you have an active leak reference TSB 212-003 Timing Gear Plate, Inspection.

Comeback repairs due to improper plate installation are non-warrantable.

Effective with R.O. Open April 26th:

Upgrading from a wet plate to an integrated seal is not covered, replacement part should be like for like.

Flywheel housings replaced for reasons other than an out of round condition, uneven sealing surface or 3 or more damaged bolt holes are not covered.

Timing gear plate repair kits are required, failure to use the kit will risk claim adjustment to reflect the price of the kits. (13L VGT Engine P/N 24459407 or 13L TC Engine P/N 24459389)

All information for internal use only

Documents

Timing Gear Plate