

August 24, 2023

Version 2

Moisture in the Headlights

Supersedes 23-012, dated June 9, 2023, to revise the information highlighted in **yellow**.

AFFECTED VEHICLES

Year	Model	Trim	VIN Range
2019–22	ILX	ALL	ALL

REVISION SUMMARY

Under PARTS INFORMATION, part names were revised.

SYMPTOM

Vehicle owner notices condensation or moisture trapped inside one or both headlight assemblies that does not evaporate from the lamp.

POSSIBLE CAUSE

The headlight making contact with a body panel can create a separation in the adhesive between the headlight lens and the housing, allowing moisture to enter the headlight.

CORRECTIVE ACTION

Replace the affected headlight(s) and adjust positioning to provide clearance with body panels.

TOOLS INFORMATION

Part Name	Part Number	Quantity
Trim Tool	SILTRIMTL10	1

CLIENT INFORMATION: The information in this bulletin is intended for use only by skilled technicians who have the proper tools, equipment, and training to correctly and safely maintain your vehicle. These procedures should not be attempted by "do-it-yourselfers," and you should not assume this bulletin applies to your vehicle, or that your vehicle has the condition described. To determine whether this information applies, contact an authorized Acura automobile dealer.

PARTS INFORMATION

Part Name	Part Number	Quantity
Right Headlight Assembly (Base, Premium, Tech)	33100-T3R-305	1
Right Headlight Assembly (A-Spec)	33100-T3R-306	1
Left Headlight Assembly (Base, Premium, Tech)	33150-T3R-305	1
Left Headlight Assembly (A-Spec)	33150-T3R-306	1

WARRANTY CLAIM INFORMATION

The normal warranty applies.

Base, Premium, Tech

Operation Number	Description	Flat Rate Time	Defect Code	Symptom Code	Template ID	Failed Part Number
712103	Replace Left Headlight (includes inspect, fitment, and adjust headlight)	0.7 hr	07408	03217	B23012A	33150-T3R-A71
713103	Replace Right Headlight (includes inspect, fitment, and adjust headlight)	0.7 hr			B23012B	33100-T3R-A71
712102	Replace Both Headlights (includes inspect, fitment, and adjust headlight)	0.8 hr			B23012C	33150-T3R-A71

A-Spec

712103	Replace Left Headlight (includes inspect, fitment, and adjust headlight)	0.7 hr	07408	03217	B23012D	33150-T3R-A81
713103	Replace Right Headlight (includes inspect, fitment, and adjust headlight)	0.7 hr			B23012E	33100-T3R-A81
712102	Replace Both Headlights (includes inspect, fitment, and adjust headlight)	0.8 hr			B23012F	33150-T3R-A81

Skill Level: Repair Technician

INSPECTION PROCEDURE

1. Visually inspect the vehicle for any areas of potential body interference. Body stresses may include the area where the fender, hood, and headlight meet.
2. Inspect to see if the tip of the fender is touching the headlight as shown below.



3. There should be clearance between the headlight and the fender as shown below.

OK



NO GOOD



4. If the headlight is contacting the fender, refer to the REPAIR PROCEDURE.

REPAIR PROCEDURE

1. Remove the front bumper by removing the bolts, screws, and the clips.

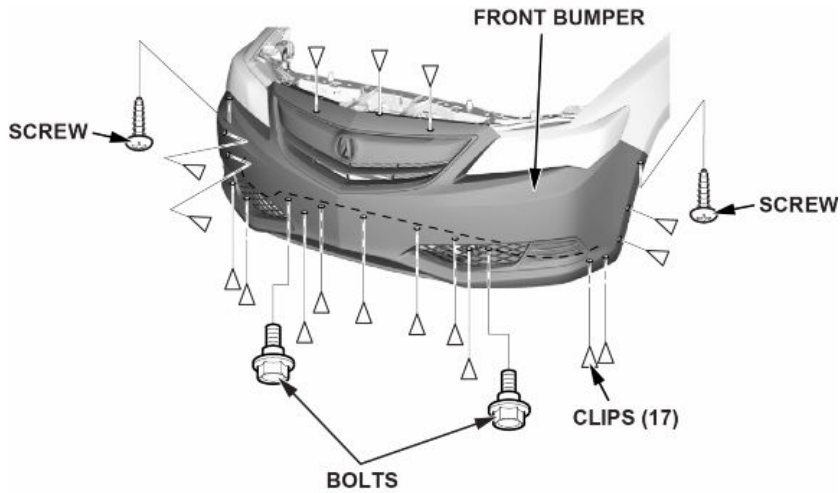

2. Pull out the front bumper at the wheel arch area to release it from the hooks on the side spacer.

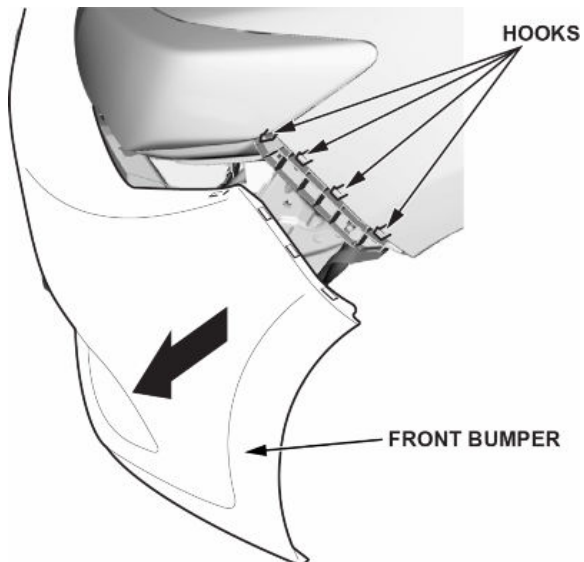

3. With the help of an assistant, while pulling the front bumper away from the side spacer, release the bumper from the hooks on the upper beam.

4. Release the pins (five places) of the front bumper from the center upper beam.

NOTE: Take care not to scratch the headlight.

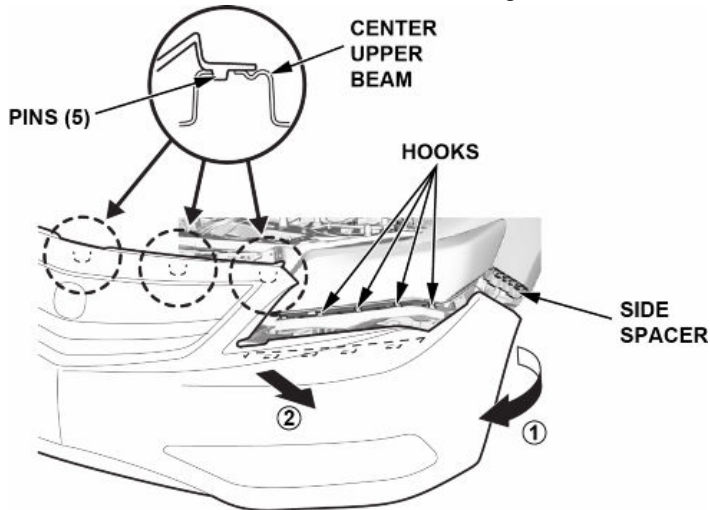

5. With the help of an assistant, disconnect the fog light subharness connector.

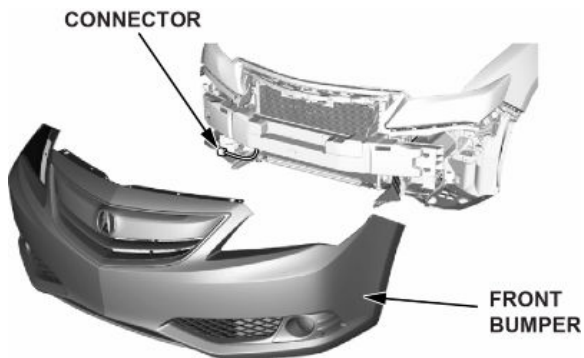

6. Remove headlight(s) mounting bolts, wiring connector, harness clips and pull forward to remove.

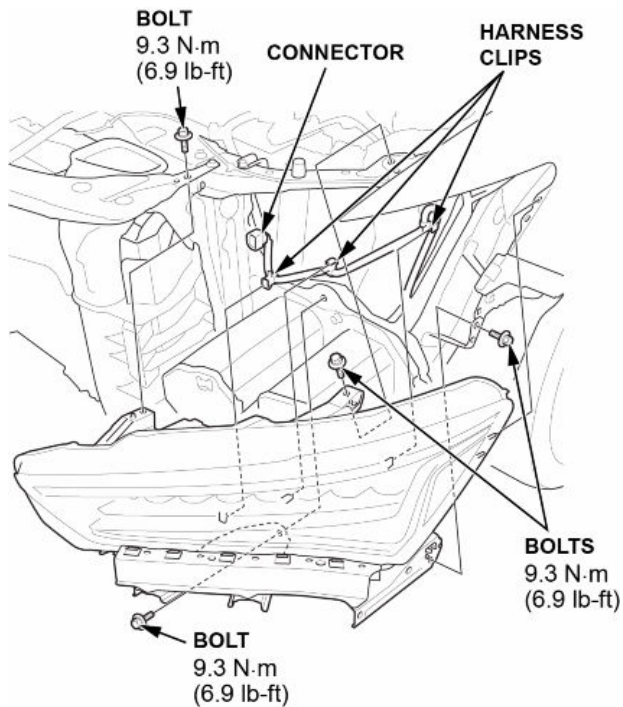

7. Remove corner upper beam from bottom of headlight.

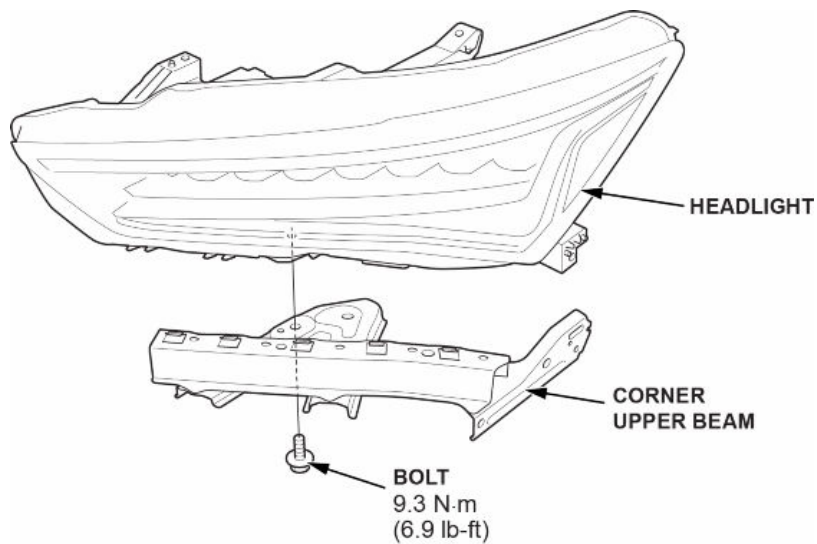

8. Install the corner upper beam to the bottom of the new headlight(s) and torque bolt to **9.3 N·m (6.9 lb-ft)**.
9. Connect the headlight connector(s) and secure the harness clips.
10. Place the headlight(s) in position and install the mounting bolts and torque bolts to **9.3 N·m (6.9 lb-ft)**, leaving the top two bolts loose.

MOUNTING BOLTS
9.3 N·m (6.9 lb-ft)



11. With help of an assistant, place the bumper back on the vehicle and install all required bolts and clips.

12. If the headlight is still making contact with the fender, use the tapered end of a plastic white trim stick between the headlight and the fender to maintain clearance while tightening the top two headlight mounting bolts.

NOTE: Be careful not to apply too much force as this could bend the fender or damage the headlight.

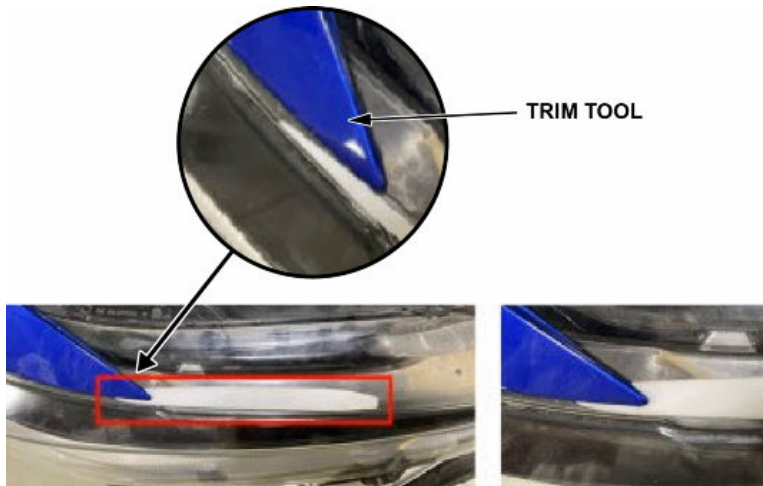

13. Remove the white stick and confirm there is no longer contact between the two surfaces.
14. If contact is still occurring, loosen the top two headlight bolts and slide two white sticks in the same location, then tighten the top two bolts.
15. Remove the white sticks and confirm there is no longer contact between the two surfaces.
16. Close hood and evaluate hood-to-fender fit and finish. Readjust as needed.
17. Do the headlight adjustment - refer to Service Information.

END