

**Snow Chain**

Model Type: 911 Dakar

Model Year: **As of 2023**

Cause: **Instructions for assembly and use**



**Information**

Illustration may differ from the rim wheel set.

**Spacer ring on the spacer pin is colored black on this model.**

Model Year: **As of 2023**

Restrictions: **NOT** approved for use on the front axle!

**NOT** approved for use with all-terrain tires!

**ONLY** approved for winter complete wheels on the rear axle with the following dimensions:

- 20-inch complete winter wheel 295/40 R 20 110V XL on 11.5 x 20 ET68 rim



Figure 1

Notes: Snow chains (⇒ Figure 1):

- have been tested and approved for the rear axle of the PORSCHE 911 Dakar.
- can be installed quickly and easily.
- are pulled automatically onto the rear wheel when installed correctly thanks to the axial preload and a short, sharp approach.
- can be repaired by retail outlets.

Parts Info: **992.091.355**

⇒ Snow chains, set

Parts List:



Figure 2

----	2 x	Snow chain, illustration deviates, a total of 7 blue crosses in the chain set ⇒ Figure 2-1-
----	1 x	Open-ended/ring wrench, a/f 13 ⇒ Figure 2-2-
----	2 x	Spacer pin length 52, illustration deviates, no red ring installed, it is <b>black</b> ⇒ Figure 2-3- on this model
----	2 x	Adapter set for wheel bolt, a/f 17 ⇒ Figure 2-4-
----	1 x	Allen key, a/f 3 ⇒ Figure 2-5-
----	8 x	Plastic joiner (blue) with Allen key and hexagon nut (M4, self-locking) ⇒ Figure 2-6-
----	1 x	Outer hexagon wrench, a/f 7 ⇒ Figure 2-7-
----	1 x	Installing gloves ⇒ Figure 2-8-
----	1 x	PORSCHE EQUIPMENT bag ⇒ Figure 2-9-
----	1 x	Instructions for assembly and use (General version – not shown)
----	1 x	Quality control sheet (not shown)

Technical Data: – Max. spring steel clip diameter (opening dimension): approx. 750 mm/ 29.53 in  
– Empty weight: 2960 g (6.53 lbs) /piece  
– 7100 g (15.65 lbs) /pair in PORSCHE TEQUIPMENT bag with accessories  
– Pack dimensions of the PORSCHE TEQUIPMENT bag: 690 mm/ 27.17 in (length)/210 mm/ 8.27 in (width)/210 mm/ 8.27 in (height)  
– **Permissible. maximum speed ( $v_{\max}$ ): 50 km/h (30 mph)**

** DANGER****Driving with snow chains**

- **Danger of injury**
  - **Risk of material damage**
- ⇒ **Snow chains may ONLY be used for driving on snow-covered and icy roads.**
- ⇒ **On partly snow-covered roads: Drive much more slowly.**
- ⇒ **Driving with snow chains in off-road areas has NOT been tested and approved.**
- ⇒ **Allow for change in vehicle handling (see Owner's Manual).**
- ⇒ **Avoid spinning wheels installed with snow chains.**
- ⇒ **Observe a maximum speed of 30 mph (50 km/h) on roads that are well covered with snow.**
- ⇒ **After a distance of 12 mls (20 km) or after emergency braking: Check that snow chains are installed correctly and check for signs of wear.**
- ⇒ **If the installed snow chain hits/touches against a curb: Check that snow chains are installed correctly and check for signs of wear.**
- ⇒ **Before starting EVERY trip: Check that the snow chain is installed/positioned correctly on the wheel.**
- ⇒ **If the vehicle needs to be towed, follow the instructions in the Owner's Manual and observe the relevant road traffic regulations that apply in your country.**

** WARNING****Installing/removing snow chains**

- **Danger of injury**
  - **Risk of damage to the wheel housing, wing and other vehicle parts**
- ⇒ **Learn how to handle snow chains by installing/removing them when dry as a test.**
- ⇒ **AFTER installing: Check clearance of the wheel WITH snow chain in extreme positions (compressed).**
- ⇒ **Always install/remove the snow chain on level ground.**
- ⇒ **Always install/remove the snow chain when the vehicle is stationary and secured (see Owner's Manual).**

- ⇒ As soon as the wheel installed with the chain moves: Keep ALL parts of the body (fingers, hands and hair) a safe distance away.
- ⇒ When tightening and loosening the tensioner: Keep ALL parts of the body (fingers, hands and hair) a safe distance away.
- ⇒ For greater visibility and for your own safety when installing/removing snow chains, wear a Hi-vis jacket (e.g. from PORSCHE EQUIPMENT).
- ⇒ Read the Installation and Conversion Instructions carefully and follow these instructions exactly during installing/removal.
- ⇒ Observe the specified tire pressure (see Owner's Manual). Reducing the tire pressure for installing/removal is NOT permitted.
- ⇒ Observe the snow chains' substantial own weight.

 **WARNING****Using snow chains**

- Danger of injury
- Risk of material damage
- ⇒ Snow chains may **ONLY** be used if the vehicle and tire and rim combination have been approved by Porsche for the use of snow chains.
- ⇒ Incorrect and improper use of snow chains, e.g. pulling, lifting or other actions, is **NOT** permitted! After installing snow chains correctly, **ONLY** use them for driving on suitable surfaces.
- ⇒ The use of one snow chain is **NOT** permitted. **ALWAYS** use snow chains on the left and right side of the vehicle when installing them on the rear axle.
- ⇒ Visually check previously used snow chains before installing. Damaged or broken snow chains must **NEVER** be used. This applies even if the wire diameter of a chain link is more than half worn in just a small area.
- ⇒ Broken chain elements can be repaired at retail outlets. **ONLY** use genuine spare parts for repairs.
- ⇒ After use: Clean/wash snow chains and leave them to dry. Store snow chains away from damaging chemicals.

**Information**

Please inform the customer of this accordingly.

Assembly: 1 Preparatory work

- 1.1 Check whether the installed tire / wheel combination on the rear axle is listed / approved in the Manufacturer's Certificate (⇒ "911 Dakar", Owner's Manual, section on "Tires and wheels")

- 1.2 **ONLY** for vehicles with Porsche Active Suspension Management (PASM = 1BK):  
Check chassis setup. To install the snow chain, set the chassis level to "Lift" if necessary (⇒ "911 Dakar", Owner's Manual, section on "Porsche Active Suspension Management (PASM)").
- 1.3 Remove snow and ice from around the wheel housings on the rear axle.
- 1.4 Unpack snow chain and read instructions carefully.
- 1.5 Check previously used snow chain for damage/breaks.

The wire diameter must **NOT** be worn by more than half at any point!



**Information**

The snow chain is pre-set for use on the approved wheel size and can be installed immediately!

- 1.6 **ONLY** when using the snow chain on various wheel sizes or on heavily used winter tires:  
Adjust the size/length of the snow chain if necessary.

- 1 – Plastic joiner (blue)
- 2 – Hexagon socket screw, M4 x 39
- 3 – M4 hexagon nut (self-locking)

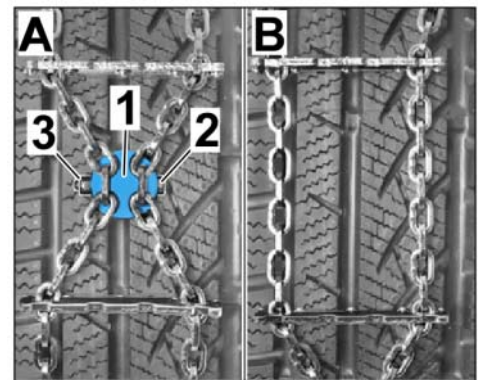

Figure 3

- 1.6.1 To "shorten" the snow chain (⇒ *Figure 3-A-*):  
Remove threaded connection from plastic joiner (blue) using the supplied tool.

Position two parallel chain strands in the middle of the plastic joiner (blue).

Install threaded connection in the plastic joiner (blue) and parallel chain links (2 ea.) using the supplied tool.

- 1.6.2 "Extend" snow chain (⇒ *Figure 3-B-*):  
Remove threaded connection in the plastic joiner (blue) and parallel chain links (2 pieces) using the supplied tool.

Remove plastic joiner (blue) from parallel chain strands.

2 Install snow chain



**Information**

The "spacer bolt, clamping sleeve and clamping piece" assembly must **NOT** be installed on a coded wheel bolt or a wheel bolt with anti-theft protection.

ALWAYS install spacer bolt on a "normal" wheel bolt!

## 2.1 Install spacer bolt on any wheel bolt on the rear wheel (left/right side)

- 2.1.1 Install clamping piece (⇒ *Figure 4 -1-*) in clamping sleeve (⇒ *Figure 4 -2-*).

- 1 – Clamp
- 2 – Clamping sleeve
- 3 – Spacer bolt
- 4 – Wheel bolt

- 2.1.2 Loosely pre-install spacer bolt (⇒ *Figure 4-3-*) in clamping sleeve (⇒ *Figure 4-2-*).

- 2.1.3 Install assembly (spacer bolt, clamping sleeve and clamping piece) on wheel bolt, paying attention to the “hexagon contour” (slot on wheel bolt edge) of the wheel bolt (⇒ *Figure 4 -bottom-*).

- 2.1.4 Tighten spacer bolt using the supplied open-ended/ring wrench, a/f 13 (⇒ *Figure 5*).

- 1 – Clamping sleeve
- 2 – Spacer bolt
- 3 – Open-ended/ring wrench, a/f 13

Alternatively, a torque wrench can also be used.

Tightening torque for spacer bolt (left/right rear wheel): **Tightening torque 20 Nm (14.8 ftlb.) +5 Nm (3.7 ftlb.)**



#### Information

If there is an imbalance after installing: Install spacer bolt and adapter on the opposite wheel bolt.

When driving for a long period of time (continuous driving) without snow chains: Remove spacer bolt and adapter from the wheel bolt.

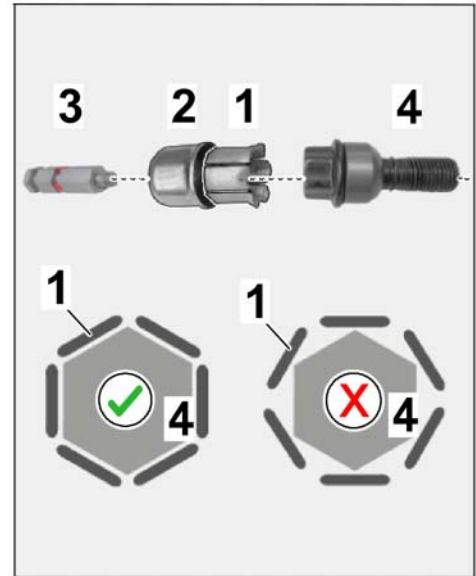

Figure 4



Figure 5

2.2 Position snow chain on rear wheel

Snow chain components:

- 1 – Spring steel arm
- 2 – Plastic support
- 3 – Chain net
- 4 – Fastening lever with safety flap (orange)
- 5 – Knob
- 6 – Plastic joiner (blue)

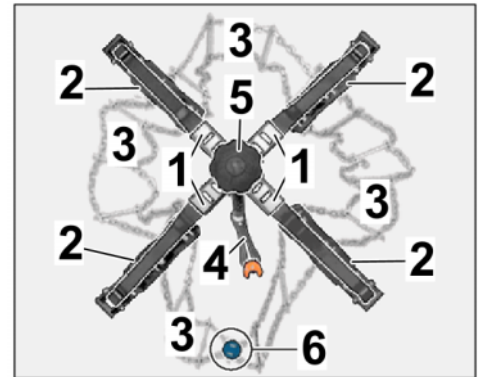

Figure 6

2.2.1 Open spring steel arms with plastic supports on the snow chain and sort out the chain net (⇒ Figure 6).

2.2.2 Open two adjacent plastic supports (⇒ Figure 7-A) and guide them with the chain net from above as shown ⇒ Figure 7 as far as possible over the rear wheel (⇒ Figure 7-B).

2.3 Secure snow chain on rear wheel

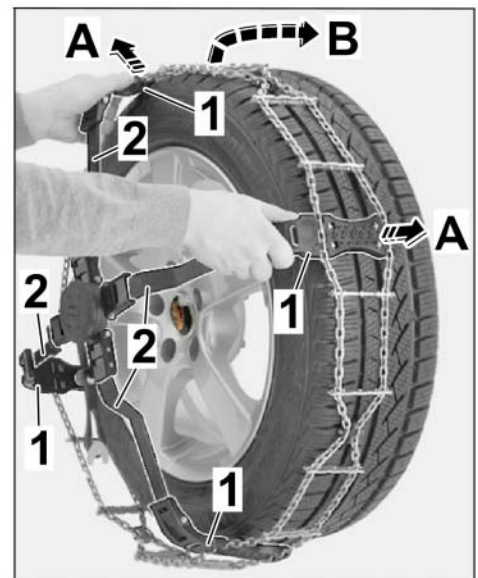

Figure 7



**Information**

- Always check that there is sufficient distance between the fastening lever (with safety flap) and the rim!
- Do **NOT** remove the red ring (⇒ Figure 8, item 4) in the groove on the spacer bolt!



- 1 – Spacer pin, illustration deviates, no **red** ring installed. It is **black** on this model.
- 2 – Fastening lever with safety flap (orange)
- 3 – Cut through rim
- 4 – Ring (black)

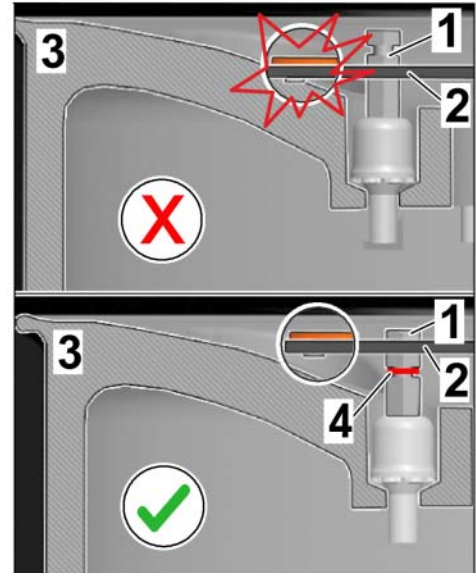

Figure 8

- 2.3.1 Engage fastening lever, with the safety flap (orange) visibly facing outwards, into a free groove on the spacer bolt (⇒ Figure 9-A and B-).

- 1 – Fastening lever
- 2 – Safety flap (orange)
- 3 – Spacer bolt

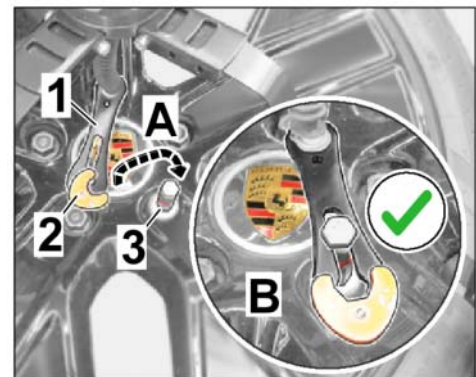

Figure 9



2.3.2 Press knob on snow chain onto the rear wheel (⇒ *Figure 10-A*).

- 1 – Knob
- 2 – Bellows

At the same time, turn the knob as far as it will go to the right (plus "+" sign ⇒ *Figure 10-B*) until the bellows is pressed together (⇒ *Figure 10-C*).

2.4 Pull snow chain completely onto the rear wheel

To pull the snow chain completely onto the rear wheel, briefly accelerate sharply.

2.5 Check that the snow chain is installed correctly on the rear wheel by looking at the rear wheel from above. Check the following:

- Sufficient distance between the snow chain (spring steel arms, fastening lever) and the rim
- Safety flap (orange) must not be facing the rim/wheel
- The knob must only be turned/tensioned until the bellows is pressed together.

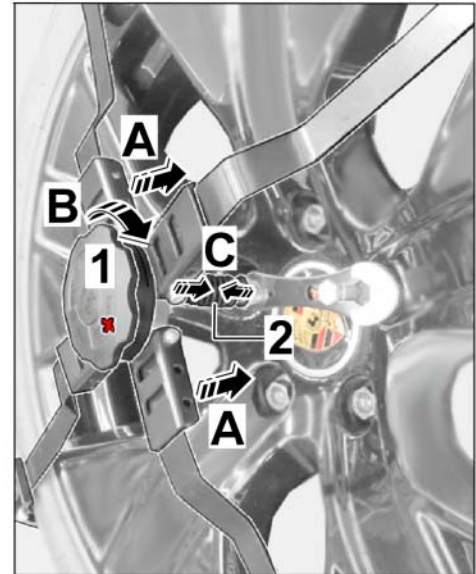

Figure 10

Removal: 3 Remove snow chain

3.1 Pull the knob slightly off the rear wheel (⇒ *Figure 11-A*).

- 1 – Knob
- 2 – Fastening lever and bellows

At the same time, turn the knob to the left (minus "-" sign ⇒ *Figure 11-B*) until the fastening lever with cable and bellows (⇒ *Figure 11-C*) have become loose.

3.2 Turn the safety flap (orange) on the fastening lever until the fastening lever can be disengaged from the groove on the spacer bolt.

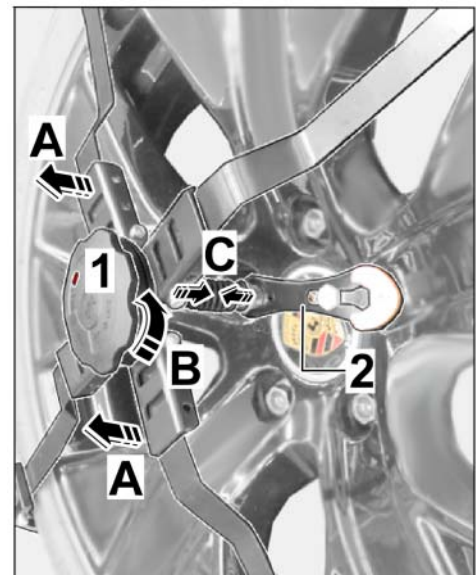

Figure 11

3.3 Pull chain net with two adjacent plastic supports off the rear wheel from above.

- 1 – Chain net
- 2 – Spacer bolt
- 3 – Clamping sleeve



Figure 12

#### NOTICE

##### Driving off the snow chain

- **Damage to snow chain components**
- ⇒ **Be careful not to drive over any other chain components (e.g. other plastic supports, spring steel arms or knobs) that are NOT under the rear wheel!**

3.4 Drive off the snow chain net (⇒ Figure 12-A-).

3.5 Remove spacer bolt with clamping sleeve and clamping piece from wheel bolt (left ⇒ Figure 12-Magnifier-/ right rear wheel).

3.6 Shake out the snow chain and stow all parts away.

Maintenance: 4 Snow chain maintenance

- Wash snow chains in hot water immediately after use and leave them to dry.
- Visually inspect the snow chain for signs of damage and adequate wire strength (chain links).
- Snow chains must **NOT** be oiled!
- After drying, stow dry snow chains back in the vehicle if necessary.
- Snow chains are made of high-quality steel, but are not rust-resistant. A small amount of rust will not impair the quality of the snow chains.

- 44 39 24 00: – Installing snow chains (2 pieces) on the rear wheels Labor time: **30 TU**  
Includes: Read instructions.  
Check snow chains for damage before use and install them.  
Check fitting.
- 44 39 20 00: – Removing/Installing snow chains (2 pieces) on rear wheels Labor time: **50 TU**  
Includes: Read instructions.  
Remove installed snow chains.  
Check snow chains for damage before use and install them.  
Check fitting.

**Important Notice:** Technical Bulletins issued by Porsche Cars North America, Inc. are intended only for use by professional automotive technicians who have attended Porsche service training courses. They are written to inform those technicians of conditions that may occur on some Porsche vehicles, or to provide information that could assist in the proper servicing of a vehicle. Porsche special tools may be necessary in order to perform certain operations identified in these bulletins. Use of tools and procedures other than those Porsche recommends in these bulletins may be detrimental to the safe operation of your vehicle, and may endanger the people working on it. Properly trained Porsche technicians have the equipment, tools, safety instructions, and know-how to do the job properly and safely. Part numbers listed in these bulletins are for reference only. The work procedures updated electronically in the Porsche PIWIS diagnostic and testing device take precedence and, in the event of a discrepancy, the work procedures in the PIWIS Tester are the ones that must be followed.

© 2023 Porsche Cars North America, Inc.