

# Technical Service Bulletin



## 19J2 UPDATE – Coolant Pump (NVLW)

May 21, 2013

Model(s)	Year	Affected Vehicles	Vehicle-Specific Equipment
TTS	2012	See Campaign/Action screen in ElsaWeb	NA

## Condition

This Update has been proactively released to prevent the following condition from occurring in the vehicle:

On Audi TTS vehicles manufactured within a specific period, it is possible that the drive sprocket for the coolant pump can come loose on the pump shaft. As a result, the delivery rate of the pump will be reduced and the coolant temperature will rise.

This Update is in effect until removed.

Vehicle must meet all of the following criteria:

- Procedure is valid only for vehicles that show the **19J2** code in the ElsaWeb Campaign/Action Information screen on the day of repair.
- Vehicle must be within the New Vehicle Limited Warranty.
- Procedure must be performed within the allotted time frame stated in this Technical Service Bulletin.
- Procedure must be performed on applicable vehicles in dealer inventory prior to sale.

## Technical Background

On Audi TTS vehicles manufactured within a specific period, it is possible that the drive sprocket for the coolant pump can come loose on the pump shaft. As a result, the delivery rate of the pump will be reduced and the coolant temperature will rise.

## Service

### Criteria 8J: Replace coolant pump

- Refer to *Repair Manual* >> *Engine* >> 19  
*Cooling System* >> *Removal and Installation*  
>> *Coolant Pump*

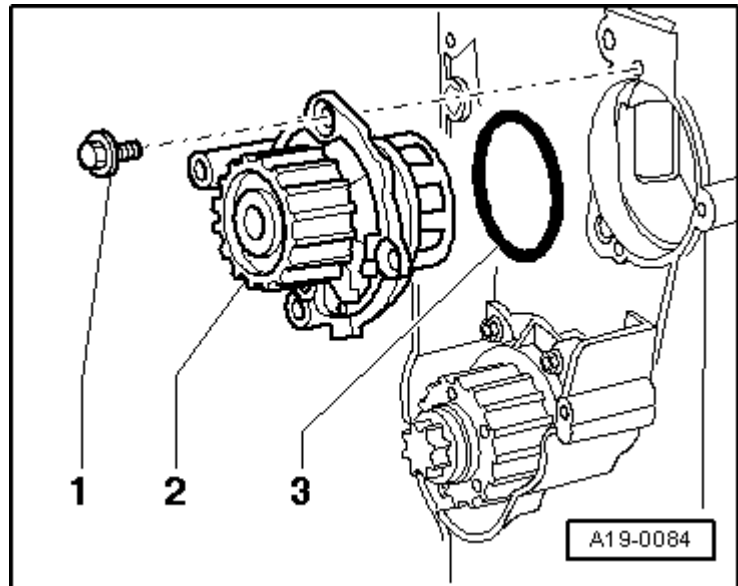

# Technical Service Bulletin



## Warranty

<b>Update Time Requirements/ Reimbursement</b>	To ensure prompt and proper payment, be sure to immediately enter the applicable reimbursement code listed below upon completion of the repair work. Claims will be paid only for vehicles that show the <b>19J2</b> code in the ElsaWeb Campaign/Action Information screen on the day of repair.		
<b>19J2 Saga Claim Entry Procedure</b>			
Check ElsaWeb to determine whether Update <b>19J2</b> is open.			
<b>Service No.: 19J2</b>			
<b>Damage Code:</b> 0099			
<b>Parts Manufacturer -</b> Removed part: 002			
<b>Claim Type</b>			
Sold vehicle = 7 10			
Unsold vehicle = 7 90			
<b>Saga Accounting Instructions</b>			
<b>Criteria ID</b>	<b>Repair operation</b>	<b>Labor Operation Number</b>	<b>TU</b>
8J	Replace coolant pump	1950 19 15	330
<b>Criteria ID</b>	<b>Part Number</b>	<b>Part Description</b>	<b>Quantity</b>
8J	06F121011 X	Coolant Pump	1
	G013A8JS0	Coolant additive	5
	N91143901	Bolt	6

# Technical Service Bulletin



There is no reimbursement for vehicle wash or loaner vehicle.

**If the vehicle is outside of the specified warranty period, the customer has the option to pay for the repair.**

*If the customer agrees to pay for the repair:*

Fax the information to (248) 754-5093 and provide VIN, applicable Service Number, Customer Info, Dealer Number and Date.

*If the customer does not agree to pay for the repair:*

Fax the information to (248) 754-5093 and provide VIN, applicable Service Number, Customer Info, Dealer Number and Date.

**Additional Actions** Some of the affected vehicles may be involved in additional Actions. Please check your ElsaWeb Campaign/Action Information screen so that any *additional required work can be done simultaneously*.

**Update Verification** For verification, *always* check the ElsaWeb Campaign/Action Information screen. The ElsaWeb system is the *only* binding inquiry and verification system; other systems are not valid and *may result in non-payment* of a claim.

**Help for Claim Input** For questions regarding claim input, contact the Warranty Helpline.

**Required Customer Notification** Inform your customer in writing by recording on the Repair Order any and all work that was conducted on the vehicle, including any and all updates completed under this Update.

## Required Parts and Tools

Part Number	Part Description	Quantity
06F121011 X	Coolant pump	1
N91143901	Bolt	6
G013A8J**	Coolant additive	0.5 liter

\*\* Depending on size of container

- Properly destroy and dispose of removed parts in accordance with all state and local requirements, unless otherwise indicated and/or requested through SAGA.
- If you have exhausted your allocated parts and you require additional parts for vehicles affected by this Update but have exceeded your Upper Order Limit, please submit your requests for additional parts via email to [upperorderlimits@audi.com](mailto:upperorderlimits@audi.com). Be sure to include the affected VINs with your order. Prior to submitting your request, ensure that each vehicle has the **19J2** code open in ElsaWeb. Your order will be reviewed and processed accordingly.

## Additional Information

All parts and service references provided in this Update are subject to change and/or removal. Always check with your Parts Department and service manuals for the latest information.