



# TECHNICAL SERVICE BULLETIN

## Equipped With Hybrid Engines - Illuminated Powertrain Malfunction Indicator Lamp With DTC P0A1E In The PCM

23-2279

31 August  
2023

### Model:

<b>Ford</b> 2020-2023 Explorer	Engine: 3.3L Hybrid
2021-2023 F-150	Engine: 3.5L Hybrid
<b>Lincoln</b> 2020-2023 Aviator	Engine: 3.0L Hybrid

**Issue:** Some 2021-2023 F-150 vehicles equipped with a 3.5L hybrid engine, 2020-2023 Explorer vehicles equipped with a 3.3L hybrid engine and 2020-2023 Aviator vehicles equipped with a 3.0L hybrid engine may exhibit a powertrain malfunction indicator lamp with diagnostic trouble code (DTC) P0A1E stored in the powertrain control module (PCM). This may be due to the belt integrated starter generator (BISG). To correct this condition, follow the Service Procedure to diagnose and repair this symptom.

**Action:** Follow the Service Procedure to correct the condition on vehicles that meet all of the following criteria:

- One of the following vehicles:
  - 2021-2023 F-150 equipped with a 3.5L hybrid engine
  - 2020-2023 Explorer equipped with a 3.3L hybrid engine
  - 2020-2023 Aviator equipped with a 3.0L hybrid engine
- Has DTC P0A1E stored in the PCM

### Parts

Service Part Number	Quantity	Description
BAGM-94RH7-800	1	Battery (800 Amp) - Refer To The Parts Catalog For The VIN Specific Application
BAGM-48H6-760	1	Battery (760 Amp) - Refer To The Parts Catalog For The VIN Specific Application
BAGM-49H8	1	Battery (850 Amp) - Refer To The Parts Catalog For The VIN Specific Application
BXT-94RH7-730	1	Battery (730 Amp) - Refer To The Parts Catalog For The VIN Specific Application
11A213	1	Starter And Alternator Assembly - Refer To The Parts Catalog For The VIN Specific Application

**Warranty Status:** Eligible under provisions of New Vehicle Limited Warranty (NVLW)/Emissions Warranty/Service Part Warranty (SPW)/Special Service Part (SSP)/Extended Service Plan (ESP) coverage. Limits/policies/prior approvals are not altered by a TSB. NVLW/Emissions Warranty/SPW/SSP/ESP coverage limits are determined by the identified causal part and verified using the OASIS part coverage tool.

### Labor Times

Description	Operation No.	Time
Diagnose And Repair Vehicle Following The Service Procedure (Do Not Use With Any Other Labor Operations)	MT232279	Actual Time

### Repair/Claim Coding

Causal Part:	11A213
Condition Code:	42

## Service Procedure

1. Perform only the first step of the Workshop Manual (WSM) pinpoint test for P0A1E:00.
  - For F-150 vehicles, perform WSM, Section 303-06 Starting System, Diagnosis and Testing, Starting System, Pinpoint Test G, Step G1.
  - For Explorer/Aviator vehicles, WSM, Section 303-06 Starting System, Diagnosis and Testing, Starting System, perform Pinpoint Test I, Step I1.
2. Was the BISG replaced in WSM Step G1/I1?
  - (1). Yes - repair is complete.
  - (2). No - proceed to Step 3.
3. Perform the second step of the WSM pinpoint test for P0A1E:00.
  - For F-150 vehicles, perform WSM, Section 303-06 Starting System, Diagnosis and Testing, Starting System, Pinpoint Test G, Step G2.
  - For Explorer/Aviator vehicles, WSM, Section 303-06 Starting System, Diagnosis and Testing, Starting System, perform Pinpoint Test I, Step I2.
4. Was the battery replaced during Step G2/I2?
  - (1). Yes - repair is complete.
  - (2). No - proceed to Step 5.
5. At the 12V battery negative post, inspect the nut securing the battery monitoring sensor to the negative battery post. (Figures 1-2) If it is loose, tighten the nut to the specified tightening value. Refer to WSM, Section 414-01 Battery, Mounting and Cables, General Procedures, Battery Disconnect and Connect.
  - For F-150 vehicles with a 3.5L hybrid engine, tighten to 55 lb.in (6.2 Nm).
  - For Explorer/Aviator vehicles equipped with a hybrid engine, tighten to 48 lb.in (5.4 Nm).

Figure 1 - F-150



Figure 2 - Explorer/Aviator

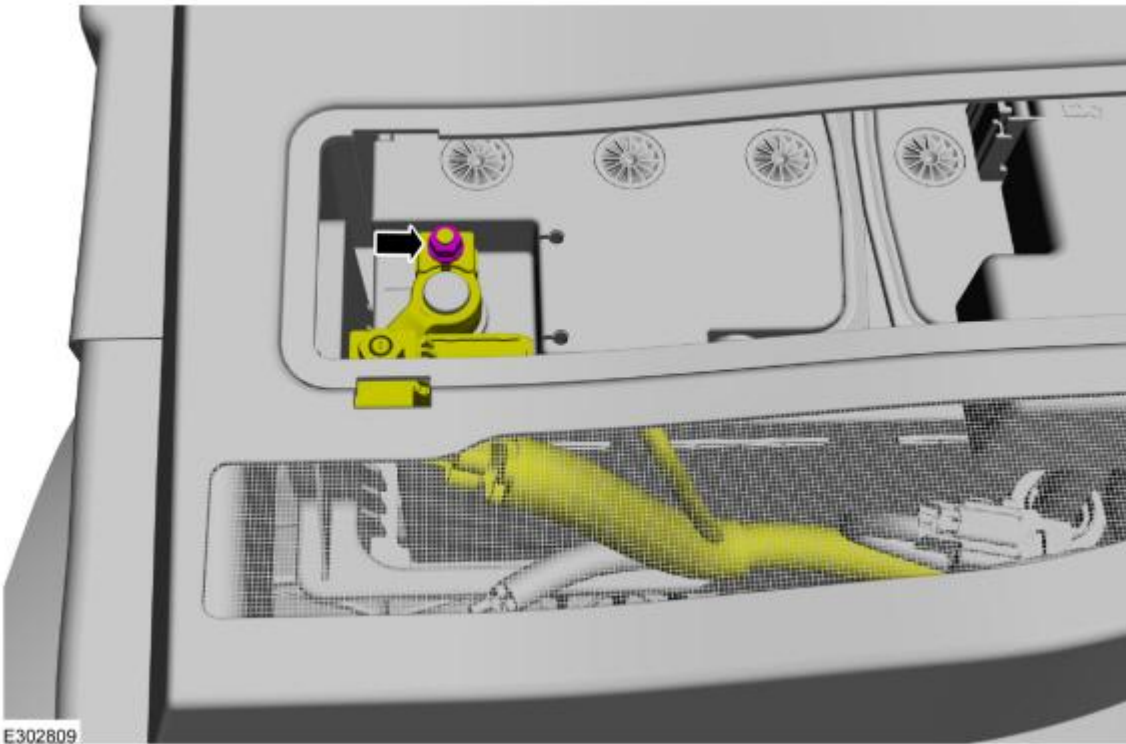

6. At the battery monitoring sensor, inspect the nut attaching the sensor to the ground cable. (Figure 3) If it is loose, tighten the nut to the specified tightening value. Refer to WSM, Section 414-01 Battery, Mounting and Cables, Removal and Installation, Battery Monitoring Sensor.

- For F-150 vehicles with a 3.5L hybrid engine, tighten to 97 lb.in (11 Nm).
- For Explorer/Aviator vehicles equipped with a hybrid engine, tighten to 80 lb.in (9 Nm).

Figure 3

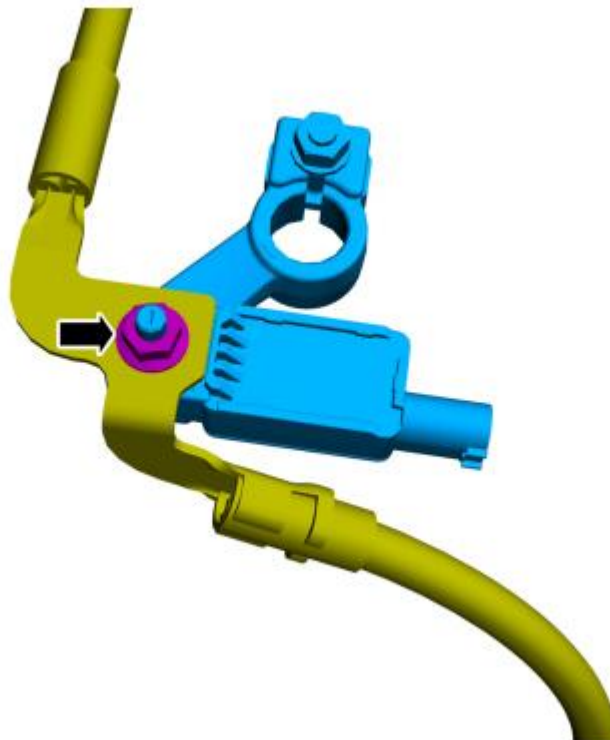

7. At the 12V battery positive post, inspect the nut securing the positive battery cable to the post. (Figures 4-5) If it is loose, tighten the nut to the specified tightening value. Refer to WSM, Section 414-01 Battery, Mounting and Cables, General Procedures, Battery Disconnect and Connect.

- For F-150 vehicles with a 3.5L hybrid engine, tighten to 55 lb.in (6.2 Nm).

- For Explorer/Aviator vehicles equipped with a hybrid engine, tighten to 48 lb.in (5.4 Nm).

Figure 4 - F-150

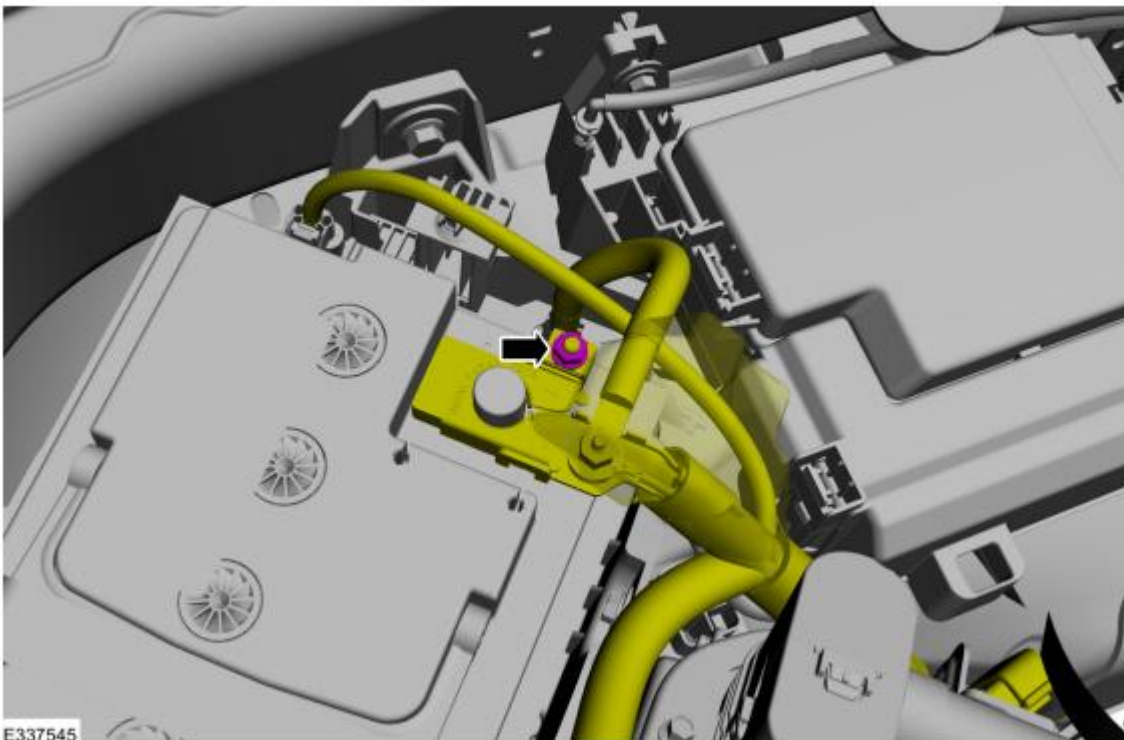
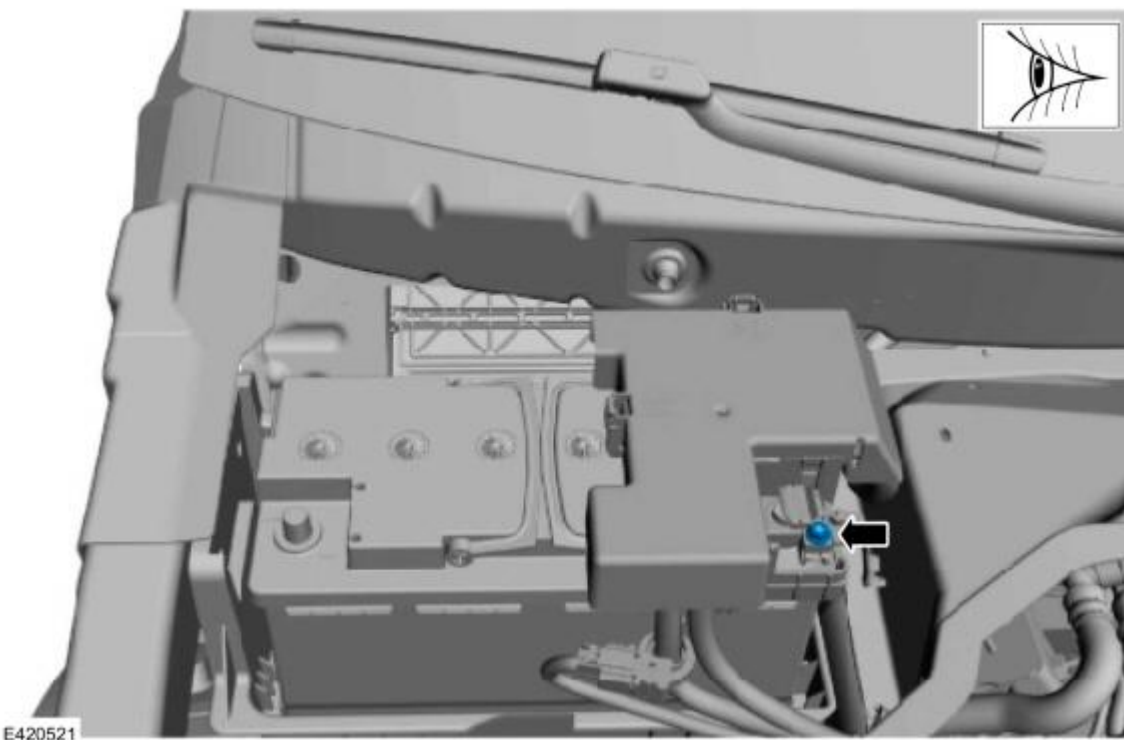

Figure 5 - Explorer/Aviator



**8.** At the 12V battery positive post, inspect the nut securing the positive cable eyelet lug. (Figures 6-7) If it is loose, tighten the nut to the specified tightening value. Refer to 414-01, Battery, Mounting and Mounting Cables, Removal and Installation.

- For F-150 vehicles with a 3.5L hybrid engine, tighten to 80 lb.in (9 Nm).
- For Explorer/Aviator vehicles equipped with a hybrid engine: 80 lb.in (9 Nm).

Figure 6 - F-150

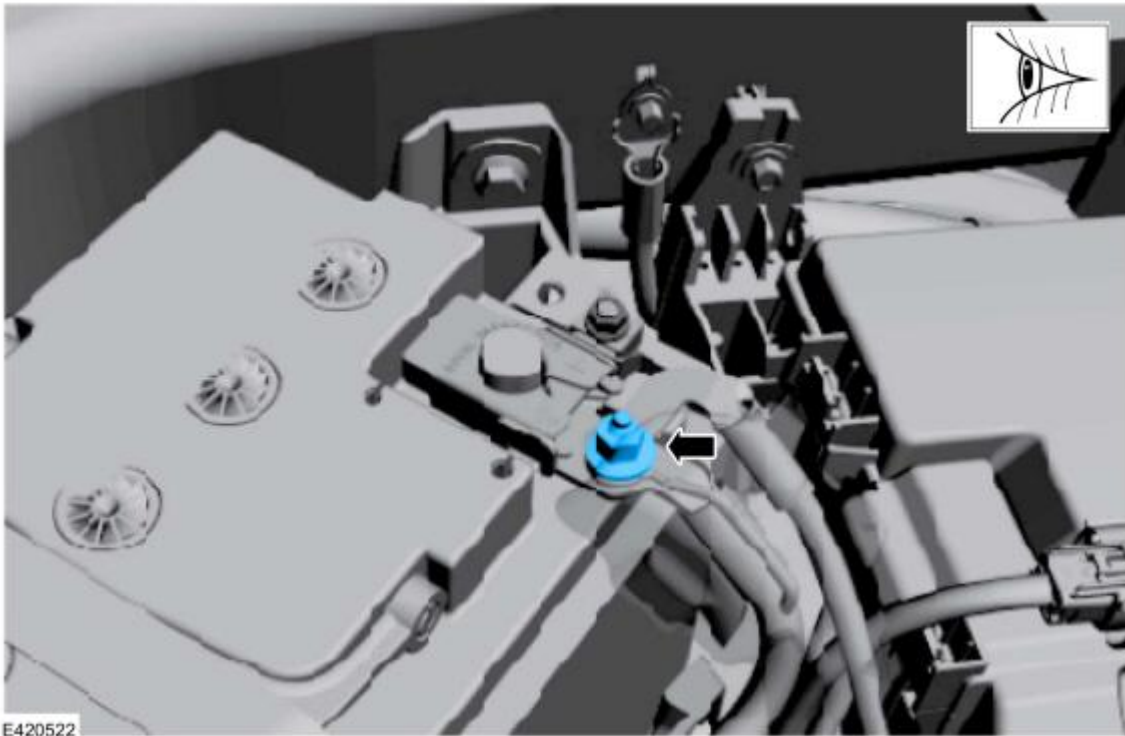
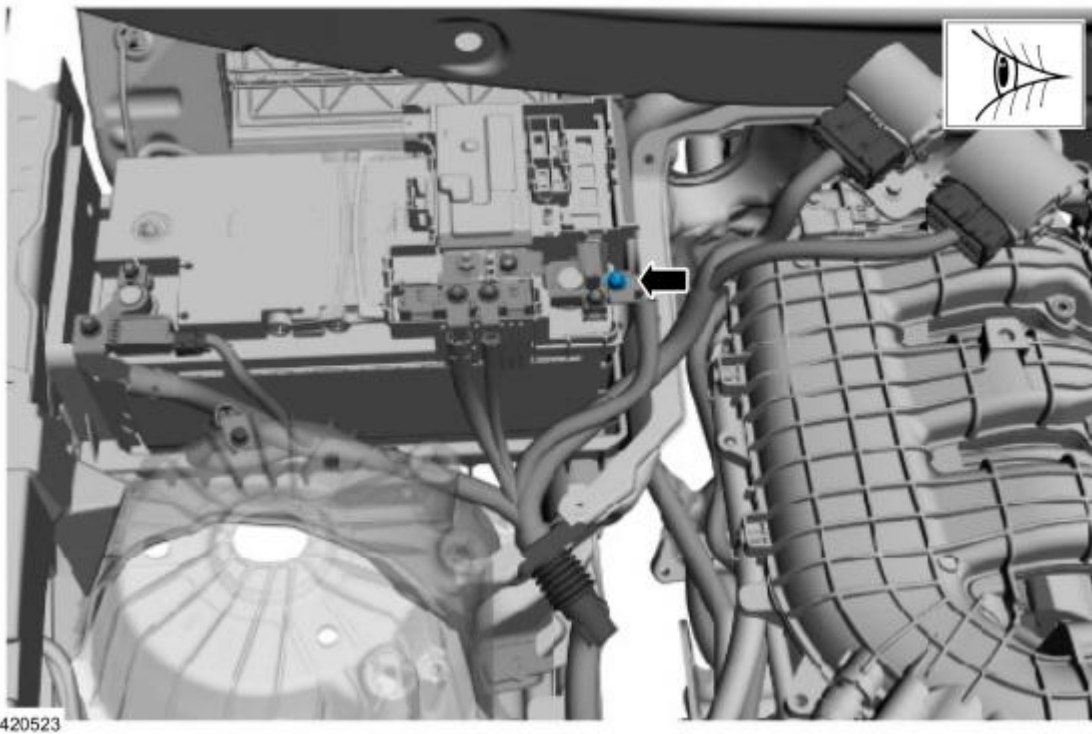

Figure 7 - Explorer/Aviator



9. Inspect engine ground G105. (Figures 8-10) Refer to Wiring Diagram, Cell 010, G105. If it is loose, tighten the bolt to the specified tightening value.

- For F-150 vehicles with a 3.5L hybrid engine, tighten to 35 lb.ft (48 Nm).
- For Explorer/Aviator vehicles equipped with a hybrid engine, tighten to 106 lb.in (12 Nm).

Figure 8 - F-150

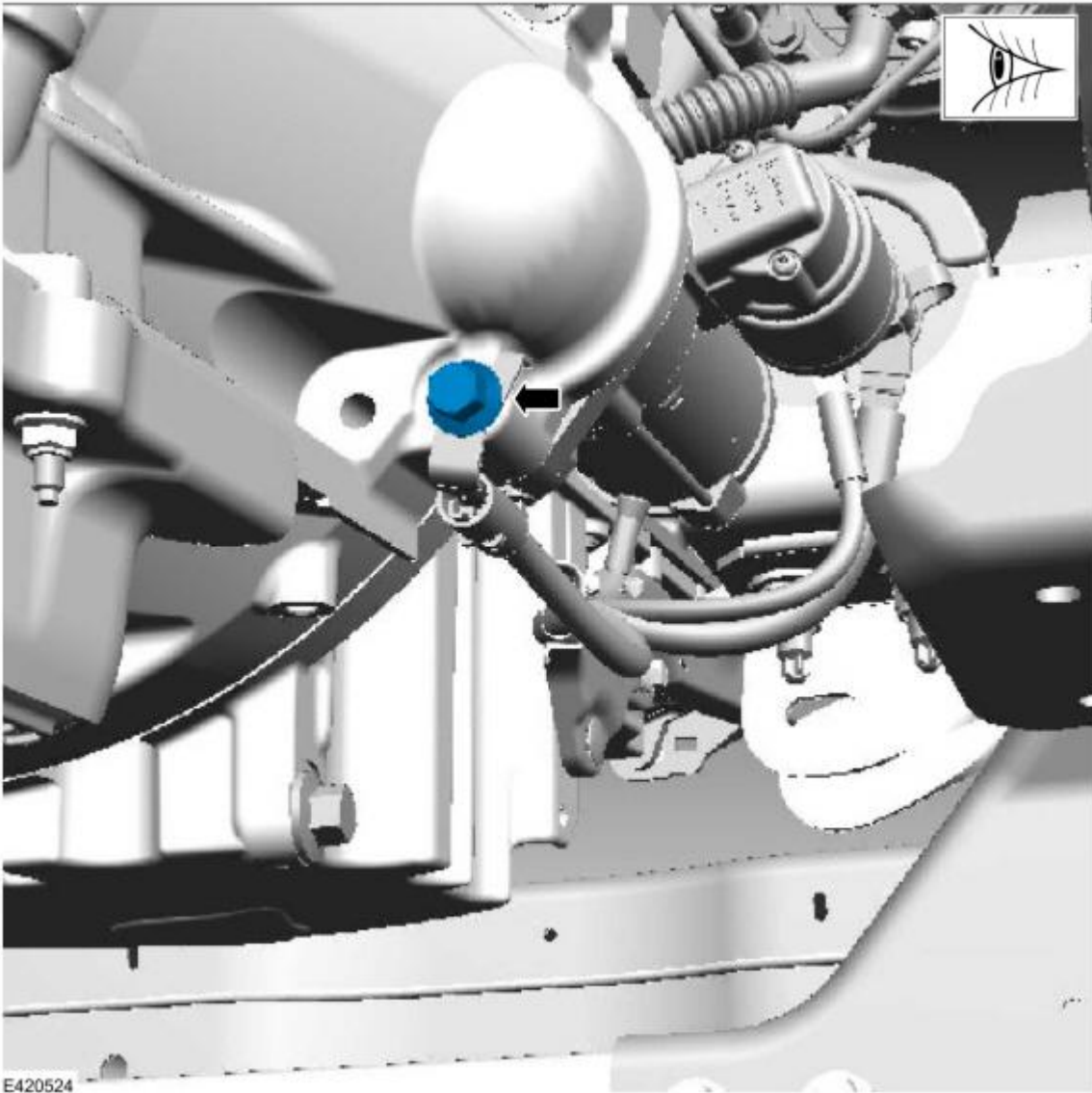

Figure 9 - Explorer

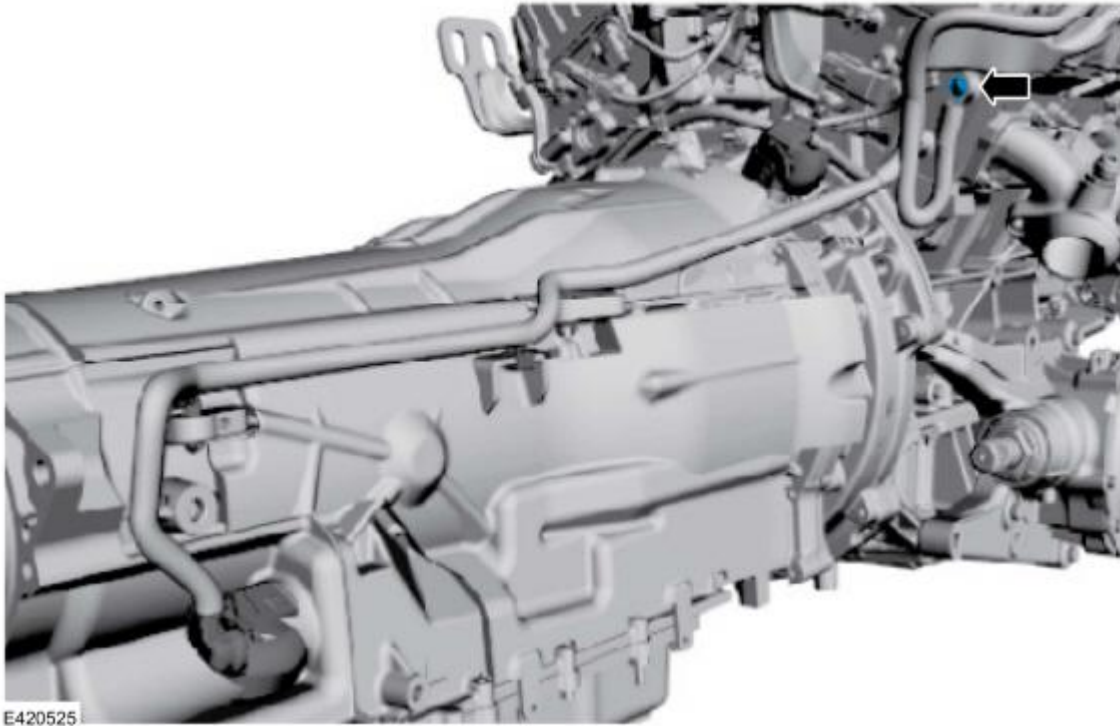
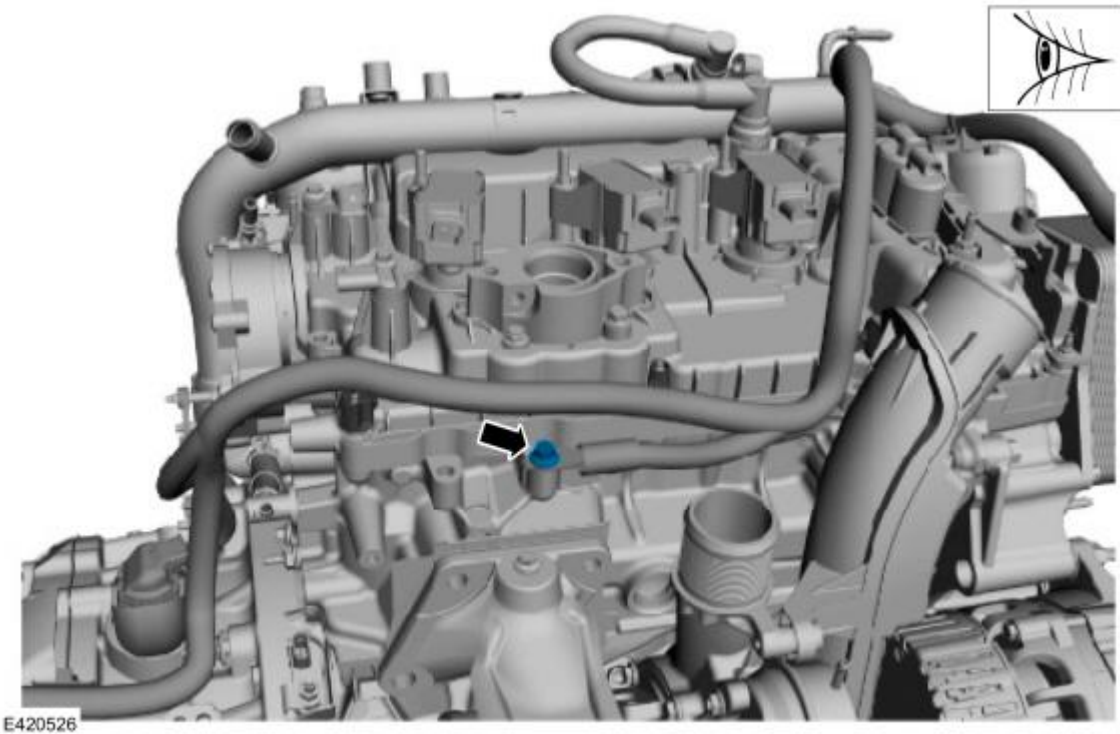

Figure 10 - Aviator



10. Were any of the nuts/bolts inspected in Steps 3-7 loose or less than their specified tightening value?

- Yes - connections were repaired, repair is complete.
- No - replace the BISG. Refer to WSM, Section 414-02 Generator and Regulator, Removal and Installation.

and Extended Service Plan documentation determine Warranty and/or Extended Service Plan coverage unless stated otherwise in the TSB article. The information in this Technical Service Bulletin (TSB) was current at the time of printing. Ford Motor Company reserves the right to supersede this information with updates. The most recent information is available through Ford Motor Company's on-line technical resources.