

Air Conditioning Leak Detection Dye and O-ring Joint Inspection

Service Category Vehicle Interior

Section Heating/Air Conditioning

Market USA and Mexico

Toyota Supports
ASE Certification 

Applicability

YEAR(S)	MODEL(S)	ADDITIONAL INFORMATION
2013 - 2018	CT200H, GS450H	
2022 - 2023	ES250, IS500, LX600, NX250, NX350, NX450H+	
2013 - 2023	ES300H, ES350, GX460, IS350, RX350	
2016 - 2020	GS F	
2016 - 2017	GS200T, IS200T, RC200T	
2018 - 2019	GS300	
2013 - 2020	GS350	
2013 - 2014	IS F	
2013 - 2015	IS250, IS250C, IS350C	
2016 - 2023	IS300	
2018 - 2023	LC500, LC500H, LS500, LS500H, RC300	
2021 - 2023	LC500C	
2012	LFA	
2013 - 2017	LS460	
2013 - 2016	LS600H	
2013 - 2021	LX570	
2015 - 2017	NX200T	
2018 - 2021	NX300	
2015 - 2021	NX300H	

Air Conditioning Leak Detection Dye and O-ring Joint Inspection

2015 - 2023	RC F, RC350
2023	RX350H, RX500H, RZ450E
2024	RX450H+
2013 - 2022	RX450H
2019 - 2022	UX200
2019 - 2023	UX250H

Introduction

The air conditioning dye injection tool kit has been developed to aid in identifying the location of air conditioning refrigerant leaks. Follow the procedures outlined in this service bulletin to aid in locating, inspecting, and repairing refrigerant leaks.

Air Conditioning Leak Detection Dye and O-ring Joint Inspection

Table of Contents

- [Warranty Information](#)4
 - [For USA Market](#)4
 - [For Mexico Market](#)4
- [Parts Information](#)4
 - [For USA and Mexico Markets](#).....4
- [Required Tools & Equipment](#)5
- [Air Conditioning Leak Detection Dye and injection Tool Use](#).....6
- [HVAC O-ring Joint Inspections](#) 12
 - [Inspect the Pipe Fitting Areas of the Expansion Valve and Evaporator](#)..... 12
 - [Inspect the Condenser and Pipe Fitting Area](#) 16
 - [Inspect the Compressor and Pipe Fitting Area](#) 18
 - [Inspect Other Joint Areas](#)..... 20
- [Judgement Criteria](#) 22
 - [O-ring Abnormalities](#)..... 22
 - [Sealing Surface Abnormalities \(O-ring Attachment Area\)](#) 23
 - [Sealing Surface Abnormalities \(Part Joint Area\)](#)..... 24

Air Conditioning Leak Detection Dye and O-ring Joint Inspection

Warranty Information

For USA Market

OP CODE	DESCRIPTION	TIME	OFF	T1	T2
N/A	Not Applicable to Warranty	–	–	–	–

For Mexico Market

OP CODE	DESCRIPTION	TIME	OFF	T1	T2
N/A	Not Applicable to Warranty	–	–	–	–

Parts Information

For USA and Mexico Markets

PART NUMBER	PART NAME	QTY
09874-20010*	Oil Capsule, ND-11, Fluorescence	2
09874-10010*	Oil Capsule, ND-12, Fluorescence	2

*The dye part numbers are for Denso air conditioning systems ONLY.

Air Conditioning Leak Detection Dye and O-ring Joint Inspection

Required Tools & Equipment

The table below shows a list of the components included in the air conditioning dye injection tool kit if ANY of the components requires replacement.

Table 1.

SPECIAL SERVICE TOOL (SST)				
TOOL KIT	DYE TYPE	REFRIGERANT TYPE / DESCRIPTION	SUB-PART NUMBERS	IMAGE
09870-DYEKIT*	ND-11 (09874-20010)	R-134a / Brass Coupler*	09870-10010-Y	
		R-1234yf / Brass Coupler*	09870-20010-Y	
	ND-12 (09874-10010)	R-134a / Brass Coupler*	09870-10010-B	
		R-1234yf / Brass Coupler*	09870-20010-B	
	–	Injector Handle*	09870-TP9845	
	–	Ultraviolet (UV) Flashlight*	09870-TPOPUPV	
	–	Flashlight Charger*	09870-0TP14	
	–	GLO-AWAY + Dye Cleaner*	09870-0TP19	
	–	Yellow Glasses*	09870-TP9940	
	–	Case*	09870-CASE	

*Essential SST.

NOTE

Replacement components may be ordered by calling Approved Dealer Equipment (ADE) at 1-800-368-6787 (USA) or 01-55-50103041 (Mexico).

Air Conditioning Leak Detection Dye and O-ring Joint Inspection

Required Tools & Equipment (continued)

REQUIRED TOOLS & MATERIAL	QTY
R1234YF A/C Machine	1
R134A A/C Machine	1

Air Conditioning Leak Detection Dye and Injection Tool Use

CAUTION

- Do NOT look directly into the UV flashlight and ALWAYS wear UV protection glasses.
- Wear safety glasses when connecting/disconnecting the dye injection tool from the air conditioning service port.
- Do NOT operate the air conditioning system while the dye injection tool is connected to air conditioning system.
- Do NOT connect the dye injection tool to a system that is evacuated.
- The air conditioning system MUST contain enough refrigerant to operate the compressor and circulate the fluorescence dye to find leaks.
- Do NOT mix ND-11 and ND-12 fluorescence dyes. ALWAYS use the fluorescence dye cartridge with the designated injector tool brass coupler.
- After use, store the injector tool and fluorescence cartridges in a cool place, away from sunlight.
- Dispose of ANY fluorescence dye in accordance with all local, state, and federal regulations.

NOTE

Two dye cartridges are required per vehicle service. The first cartridge will be completely purged through the brass coupler to ensure there are NO contaminants such as moisture, air, etc. The second cartridge will be injected into the air conditioning system to inspect for leaks.

1. The air conditioning dye injection tool kit includes four brass couplers to accommodate vehicles for the types of compressor oils and refrigerants, refer to the [Required Tools & Equipment](#) section for details:
 - ND-11 with R-134a compressor oil; electric compressors (09870-10010-Y)
 - ND-11 with R-1234yf compressor oil; electric compressors (09870-20010-Y)
 - ND-12 with R-134a compressor oil; belt driven compressors (09870-10010-B)
 - ND-12 with R-1234yf compressor oil; belt driven compressors (09870-20010-B)

NOTE

- ND-12 compressor oil is compatible with ND-8 oil systems.
- ND-8 compressor oil is NOT compatible with ND-12 oil systems.

Air Conditioning Leak Detection Dye and O-ring Joint Inspection

Air Conditioning Leak Detection Dye and Injection Tool Use (continued)

- Identify the compressor oil and refrigerant system type by looking at the under-hood air conditioning label for the compressor oil and refrigerant type the vehicle is using and select the corresponding dye injector tool brass coupler.

Figure 1.



1	Compressor Oil
2	Refrigerant Type and System Charge Amount

- Prepare the dye injection tool with the fluorescence dye cartridge by removing the large cap from the first cartridge.

- Completely unscrew the handle on the injector and screw the dye cartridge into it.

NOTE

When screwing on the dye cartridge to the injector handle, make sure the piston rod remains in the fully unscrewed position.

Figure 2.

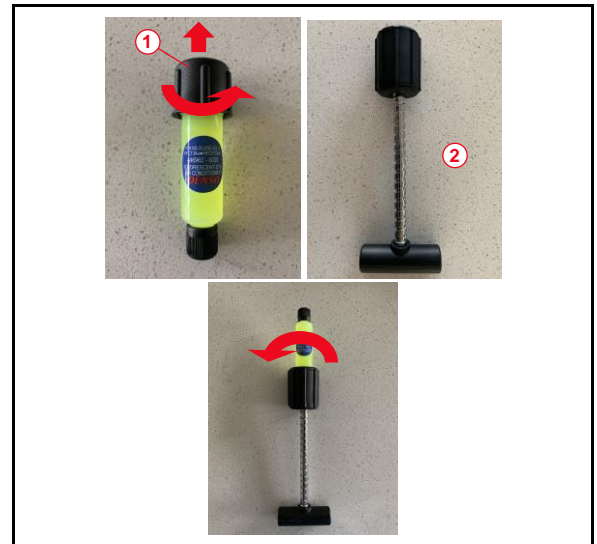

1	Large Cap
2	Dye Injection Tool

Air Conditioning Leak Detection Dye and O-ring Joint Inspection

Air Conditioning Leak Detection Dye and Injection Tool Use (continued)

5. Remove the purge fitting from the brass coupler and hold the cartridge vertically with the small cap on top.
6. Remove the cap and screw the cartridge firmly to the brass coupler.
7. Insert the purge fitting into the brass coupler.
8. AFTER the purge fitting is installed, continue holding the dye injection tool in the vertical position to avoid dye from leaking out until the purge process is complete.
9. Turn the handle to advance the plunger until it stops, passing all the dye out of the cartridge.
10. Remove the purge fitting from the brass coupler.
11. Completely unscrew the handle on the injector and unscrew the first empty cartridge from the brass coupler and dispose.
12. Install the second cartridge onto the brass coupler.

Figure 3.

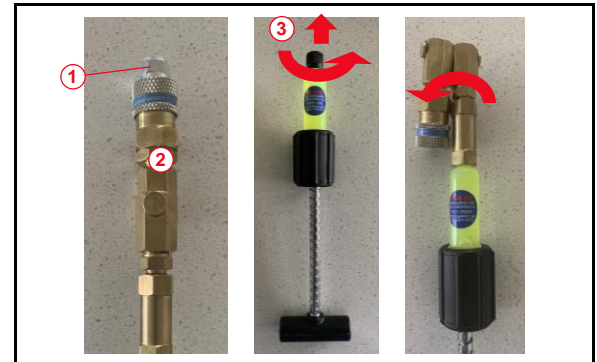

1	Purge Fitting
2	Brass Coupler
3	Hold Cartridge Vertically

Air Conditioning Leak Detection Dye and O-ring Joint Inspection

Air Conditioning Leak Detection Dye and Injection Tool Use (continued)

13. Install the purge fitting to the brass coupler and turn the handle to advance the plunger until a small amount of fluorescent dye exits the purge fitting.

Figure 4.



1	Fluorescent Dye
----------	------------------------

14. Remove the purge fitting. The injection tool assembly is now purged and ready for use.
15. Connect the brass coupler to the low side service port.

NOTE

Wrap the coupler connection with a shop rag as a small amount of fluorescence dye may spray out due to refrigerant pressure.

Figure 5.

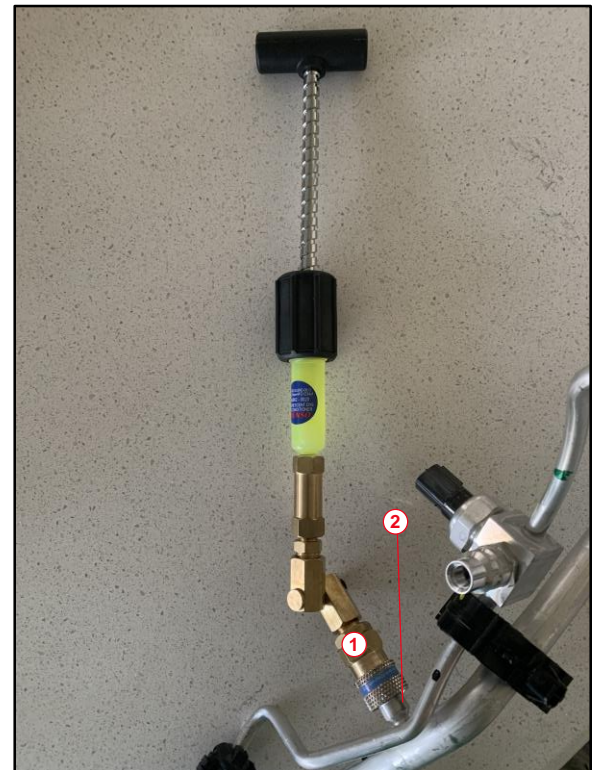

1	Brass Coupler
2	Low Side Service Port

Air Conditioning Leak Detection Dye and O-ring Joint Inspection

Air Conditioning Leak Detection Dye and Injection Tool Use (continued)

16. Turn the plunger clockwise to inject all the dye into the vehicle.

Figure 6.

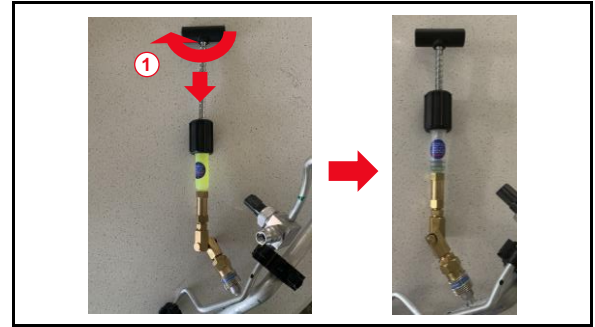

1 Turn Clockwise

17. Disconnect the brass coupler from the service port and wipe both clean.

NOTE

Wrap the coupler connection with a shop rag as a small amount of fluorescence dye may spray out due to refrigerant pressure.

18. Start the engine, turn the air conditioning switch ON, set the temperature to MAX COOL, and run the compressor for 10 minutes to circulate the fluorescence dye through the system.

19. Turn OFF the air conditioning and engine. Put on UV glasses and check for refrigerant leaks along the air conditioning system components while shining the UV light.

HINT

- Areas where there are refrigerant leaks will glow in a bright yellow green.
- For smaller leaks, operate the air conditioning system over the next 24 to 48 hours and reinspect periodically.

Figure 7.

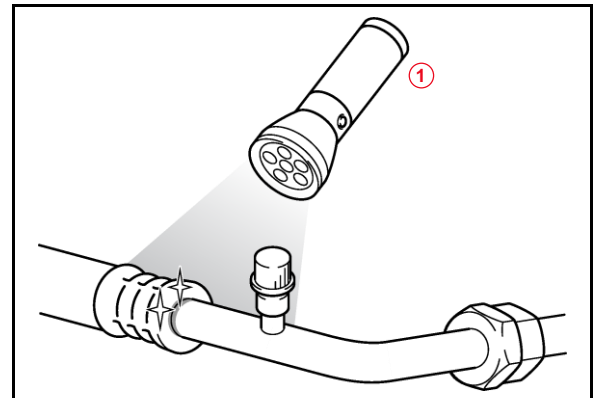

1 UV Lamp

20. AFTER the leaks are repaired, use the GLO-AWAY, dye cleaner, and UV flashlight to clean the area and ensure NO dye remains.

Air Conditioning Leak Detection Dye and O-ring Joint Inspection

Air Conditioning Leak Detection Dye and Injection Tool Use (continued)

Figure 8. Refrigerant Line

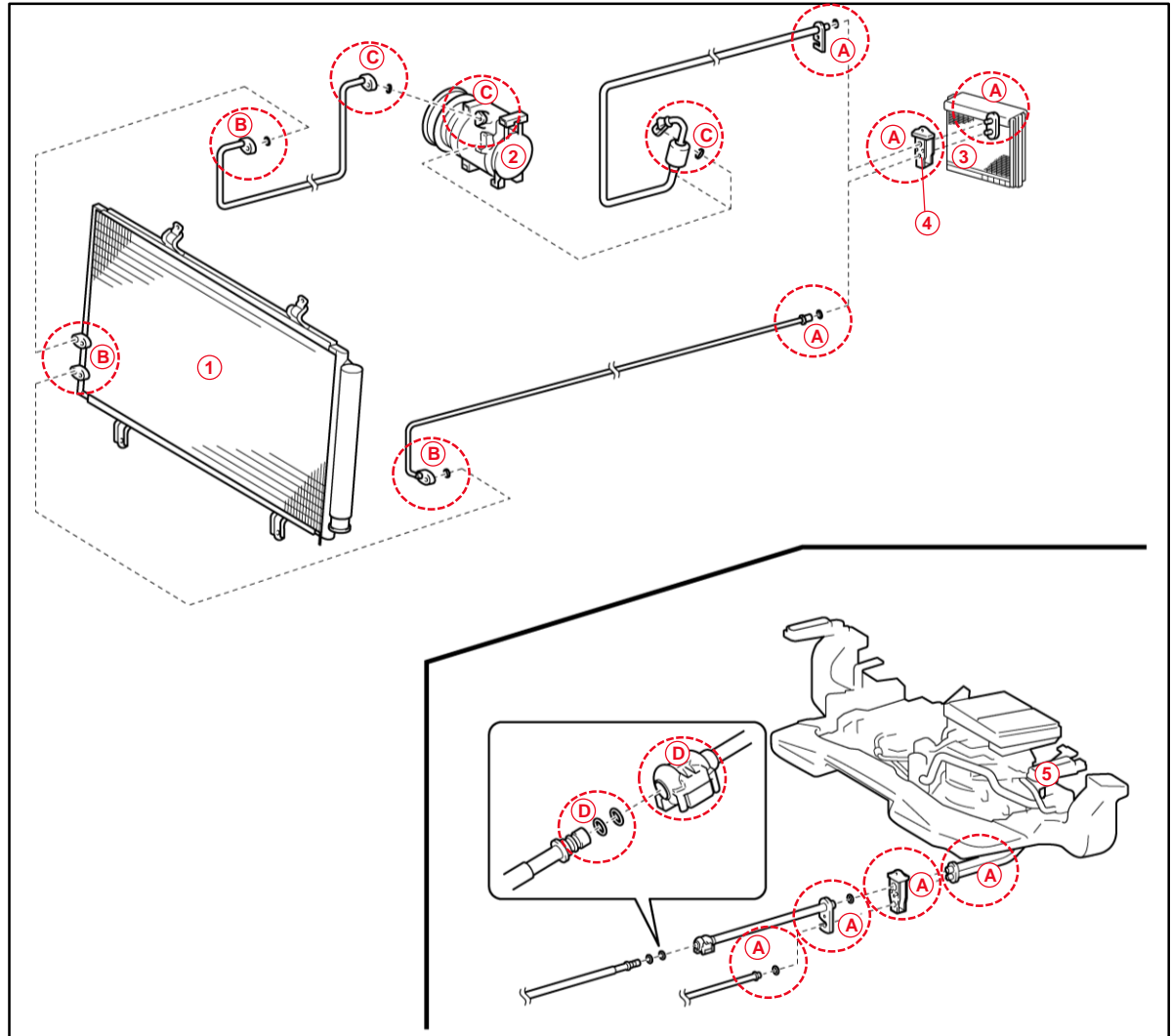

A	When leaking occurs around "A": Refer to the Inspect the Pipe Fitting Areas of the Expansion Valve and Evaporator subsection.
B	When leaking occurs around "B": Refer to the Inspect the Condenser and Pipe Fitting Area subsection.
C	When leaking occurs around "C": Refer to the Inspect the Compressor and Pipe Fitting Area subsection.
D	When leaking occurs around "D": Refer to the Inspect Other Joint Areas subsection.
1	Condenser
2	Compressor
3	Evaporator
4	Expansion Valve
5	Rear Air Conditioner

Air Conditioning Leak Detection Dye and O-ring Joint Inspection

HVAC O-ring Joint Inspections

Inspect the Pipe Fitting Areas of the Expansion Valve and Evaporator

NOTICE

- Do NOT reuse the O-rings once they are removed.
- As there may be a malfunction in multiple components, make sure to complete ALL steps and replace ALL parts in which defects are found.
- If no malfunction is found in ANY related parts, a temporary leak may have occurred due to foreign matter on an O-ring, deformation, etc.

1. Remove the pipes from the expansion valve.

NOTICE

- Wipe off the joint area with a clean cloth BEFORE disassembly.
- Slowly remove the pipes straight to prevent the sealing face from being damaged and foreign materials from dropping off.

Figure 9.

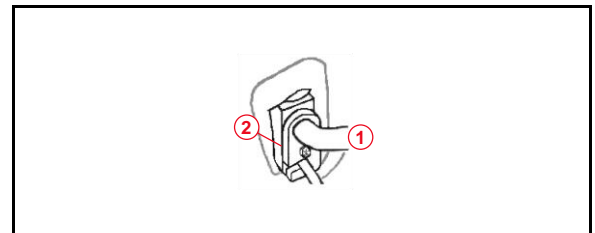

1	Pipe
2	Expansion Valve

2. Inspect the ENTIRE O-ring surfaces making sure they are free from defects, such as damage (cuts, dents, or crushed areas), foreign material adhesion, or twists. If there are ANY defects, clean or replace the part. Refer to the [O-ring Abnormalities](#) subsection for judgement criteria.

NOTICE

- Inspect the O-ring surfaces in a well-lit area.
- When it is difficult to inspect the surface conditions due to oil adhesion, degrease the surface (such as by wiping it with a clean white cloth). Make sure NOT to lose any foreign material that was adhering to the surface that may indicate the source of the leak.

Figure 10.

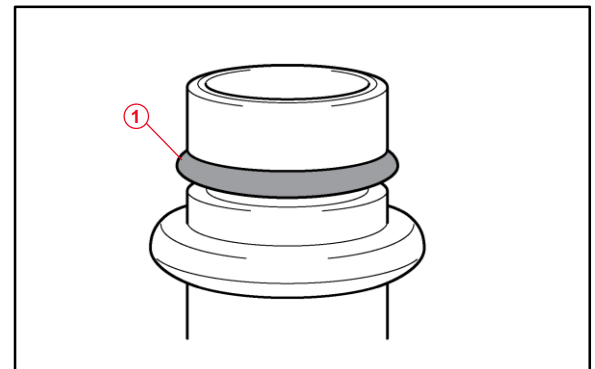

1	O-ring
---	--------

Air Conditioning Leak Detection Dye and O-ring Joint Inspection

HVAC O-ring Joint Inspections (continued)

Inspect the Pipe Fitting Areas of the Expansion Valve and Evaporator (continued)

- Remove the O-rings and inspect the entire pipe surfaces making sure they are free from defects, such as foreign material adhesion, damage, or corrosion. If there are ANY defects, clean or replace the part. Refer to the [Sealing Surface Abnormalities \(O-ring Attachment Area\)](#) subsection for judgment criteria.

NOTICE

When removing the O-rings, use soft tools (such as a toothpick) to avoid damaging the sealing face or the O-ring.

Figure 11.

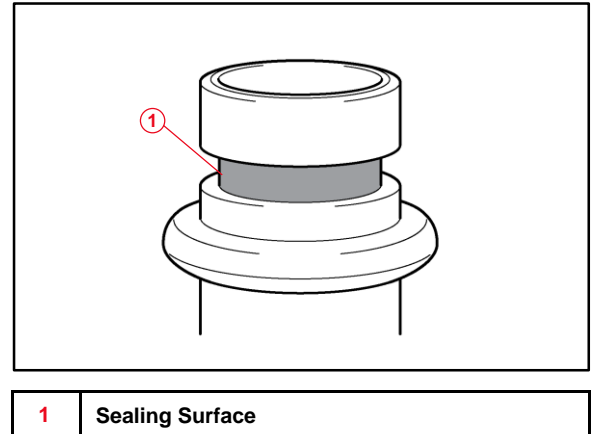

- Inspect the ENTIRE sealing surfaces of the expansion valve (pipe side) making sure they are free from defects, such as foreign material adhesion, damage, or corrosion. If there are ANY defects, clean or replace the part. Refer to the [Sealing Surface Abnormalities \(Part Joint Area\)](#) subsection for judgment criteria.

NOTICE

When it is difficult to check the surface conditions due to oil adhesion, degrease the surface (such as by wiping it with a clean white cloth). Make sure NOT to lose any foreign material that was adhering to the surface that may indicate the source of the leak.

Figure 12.

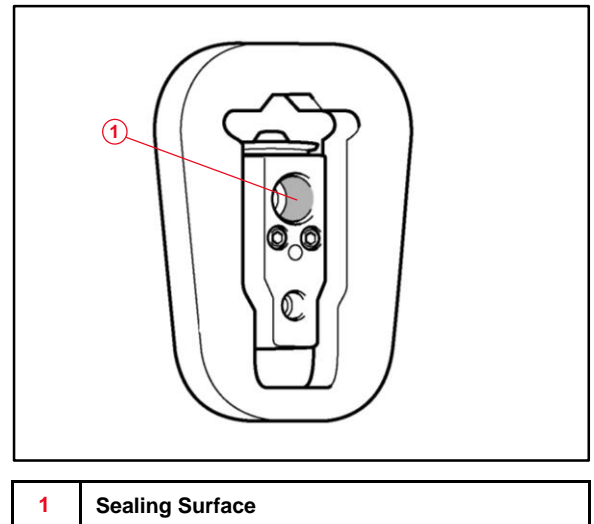

Air Conditioning Leak Detection Dye and O-ring Joint Inspection

HVAC O-ring Joint Inspections (continued)

Inspect the Pipe Fitting Areas of the Expansion Valve and Evaporator (continued)

- Remove the expansion valve from the evaporator.

NOTICE

- Slowly remove the pipes straight to prevent the sealing face from being damaged and foreign materials from dropping off.
- If the expansion valve is difficult to remove, gently move it up and down and right to left for removal.

Figure 13.

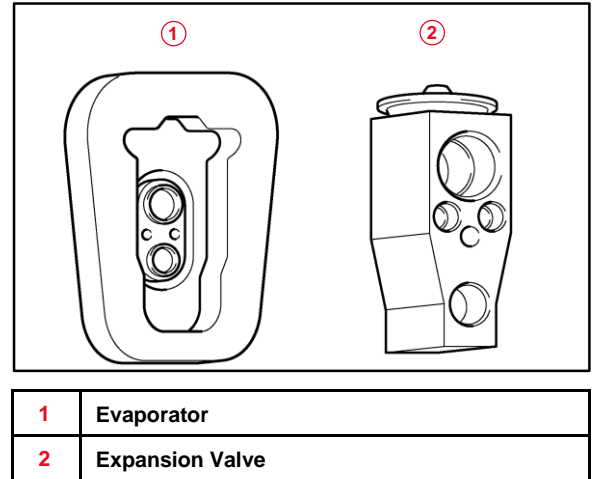

- Inspect the ENTIRE sealing surfaces of the expansion valve (evaporator side) making sure they are free from defects, such as foreign material adhesion, damage, or corrosion. If there are ANY defects, clean or replace the part. Refer to the [Sealing Surface Abnormalities \(Part Joint Area\)](#) subsection for judgment criteria.

NOTICE

When it is difficult to inspect the surface conditions due to oil adhesion, degrease the surface (such as by wiping it with a clean white cloth). Make sure NOT to lose any foreign material that was adhering to the surface that may indicate the source of the leak.

Figure 14.

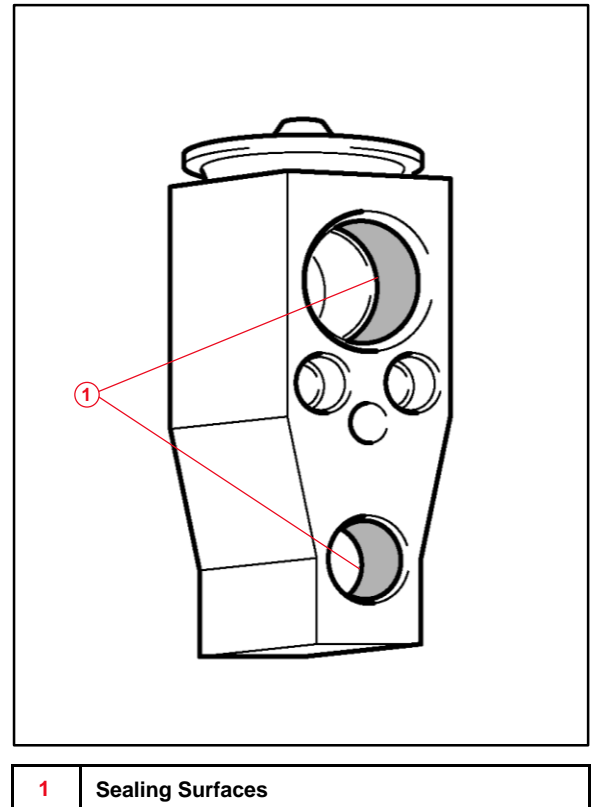

Air Conditioning Leak Detection Dye and O-ring Joint Inspection

HVAC O-ring Joint Inspections (continued)

Inspect the Pipe Fitting Areas of the Expansion Valve and Evaporator (continued)

7. Inspect the ENTIRE O-ring surfaces of the evaporator making sure they are free from defects, such as damage (cuts, dents, or crushed areas), foreign material adhesion, or twists. If there are ANY defects, clean or replace the part. Refer to the [O-ring Abnormalities](#) subsection for judgement criteria.

NOTICE

- Inspect the O-ring surfaces in a well-lit area.
- When it is difficult to inspect the surface conditions due to oil adhesion, degrease the surface (such as by wiping it with a clean white cloth). Make sure NOT to lose any foreign material that was adhering to the surface that may indicate the source of the leak.

8. Inspect the ENTIRE evaporator surface by remove the O-rings making sure they are free from defects, such as foreign material adhesion, damage, or corrosion. If there are ANY defects, clean or replace the part. Refer to the [Sealing Surface Abnormalities \(O-ring Attachment Area\)](#) subsection for judgment criteria.

NOTICE

When removing the O-rings, use soft tools (such as a toothpick) to avoid damaging the sealing face or the O-ring.

Figure 15.

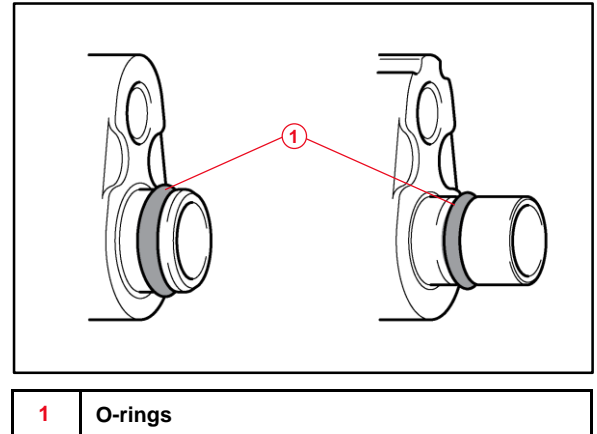
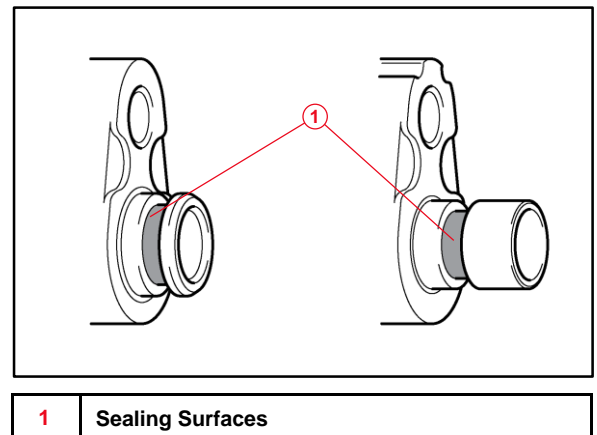

Figure 16.



Air Conditioning Leak Detection Dye and O-ring Joint Inspection

HVAC O-ring Joint Inspections (continued)

Inspect the Condenser and Pipe Fitting Area

NOTICE

- Do NOT reuse the O-rings once they are removed.
- As there may be a malfunction in multiple components, make sure to complete ALL steps and replace ALL the parts in which defects are found.
- If no malfunction is found in ANY related parts, a temporary leak may have occurred due to foreign matter on an O-ring, deformation, etc.

1. Remove the discharge and liquid pipes from the condenser.

NOTICE

- Wipe off the joint area with a clean cloth before disassembly.
- Slowly remove the pipes straight to prevent the sealing face from being damaged and foreign materials from dropping off.

Figure 17.

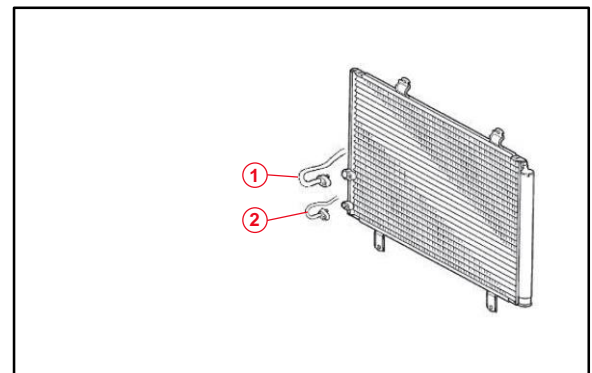

1	Discharge Side
2	Liquid Side

2. Inspect the ENTIRE O-ring surfaces making sure they are free from defects, such as damage (cuts, dents, or crushed areas), foreign material adhesion, or twists. If there are ANY defects, clean or replace the part. Refer to the [O-ring Abnormalities](#) subsection for judgement criteria.

NOTICE

- Inspect the O-ring surfaces in a well-lit area.
- When it is difficult to inspect the surface conditions due to oil adhesion, degrease the surface (such as by wiping it with a clean white cloth). Make sure NOT to lose any foreign material that was adhering to the surface that may indicate the source of the leak.

Figure 18.

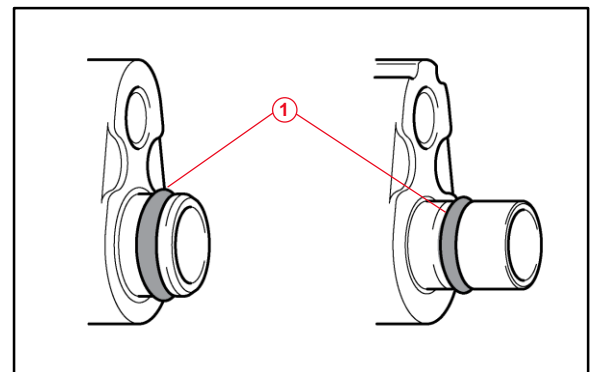

1	O-rings
---	---------

Air Conditioning Leak Detection Dye and O-ring Joint Inspection

HVAC O-ring Joint Inspections (continued)

Inspect the Condenser and Pipe Fitting Area (continued)

3. Inspect the ENTIRE pipe surfaces by removing the O-rings making sure they are free from defects, such as foreign material adhesion, damage, or corrosion. If there are ANY defects, clean or replace the part. Refer to the [Sealing Surface Abnormalities \(O-ring Attachment Area\)](#) subsection for judgment criteria.

NOTICE

When removing the O-rings, use soft tools (such as a toothpick) to avoid damaging the sealing face or the O-ring.

Figure 19.

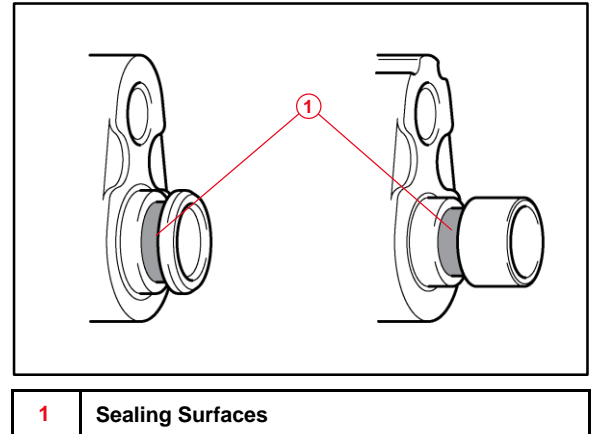

4. Inspect the ENTIRE sealing surface of the condenser making sure it is free from defects, such as foreign material adhesion, damage, or corrosion. If there are ANY defects, clean or replace the part. Refer to the [Sealing Surface Abnormalities \(Part Joint Area\)](#) subsection for judgment criteria.

NOTICE

When removing the O-rings, use soft tools (such as a toothpick) to avoid damaging the sealing face or the O-ring.

Figure 20.

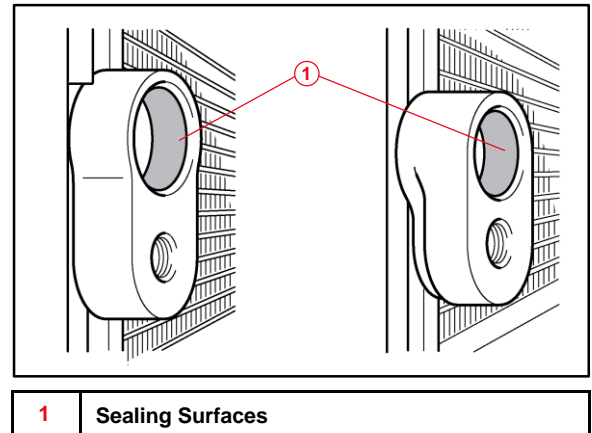

Air Conditioning Leak Detection Dye and O-ring Joint Inspection

HVAC O-ring Joint Inspections (continued)

Inspect the Compressor and Pipe Fitting Area

NOTICE

- Do NOT reuse the O-rings once they are removed.
- As there may be a malfunction in multiple components, make sure to complete ALL and replace ALL the parts in which defects are found.
- If no malfunction is found in ANY related parts, a temporary leak may have occurred due to foreign matter on an O-ring, deformation, etc.

1. Remove the discharge and suction pipes from the compressor.

NOTICE

- Wipe off the joint area with a clean cloth before disassembly.
- Slowly remove the pipes straight to prevent the sealing face from being damaged and foreign materials from dropping off.

Figure 21.

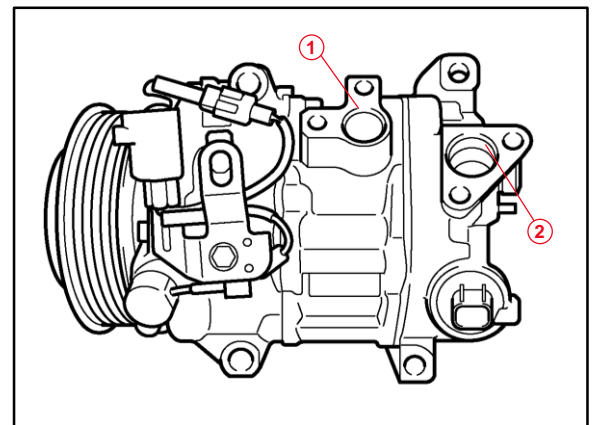

1	Discharge Side
2	Suction Side

2. Inspect the ENTIRE O-ring surfaces making sure they are free from defects, such as damage (cuts, dents, or crushed areas), foreign material adhesion or twists. If there are ANY defects, clean or replace the part. Refer to the [O-ring Abnormalities](#) subsection for judgement criteria.

NOTICE

- Inspect the O-ring surfaces in a well-lit area.
- When it is difficult to inspect the surface conditions due to oil adhesion, degrease the surface (such as by wiping it with a clean white cloth). Make sure not to lose any foreign material that was adhering to the surface that may indicate the source of the leak.

Figure 22.

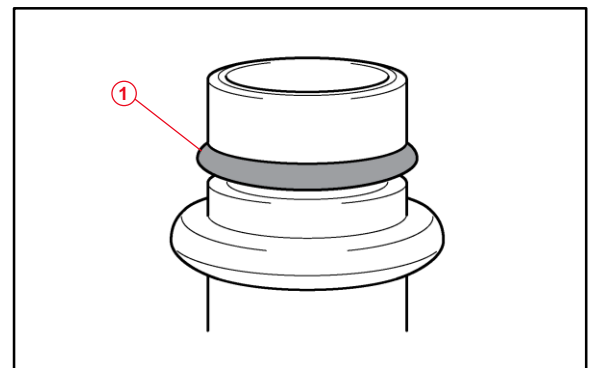

1	O-ring
---	--------

Air Conditioning Leak Detection Dye and O-ring Joint Inspection

HVAC O-ring Joint Inspections (continued)

Inspect the Compressor and Pipe Fitting Area (continued)

3. Inspect the entire pipe surfaces by removing the O-rings making sure they are free from defects, such as foreign material adhesion, damage, or corrosion. If there are ANY defects, clean or replace the part. Refer to the [Sealing Surface Abnormalities \(O-ring Attachment Area\)](#) subsection for judgement criteria.

NOTICE

When removing the O-rings, use soft tools (such as a toothpick) to avoid damaging the sealing face or the O-ring.

Figure 23.

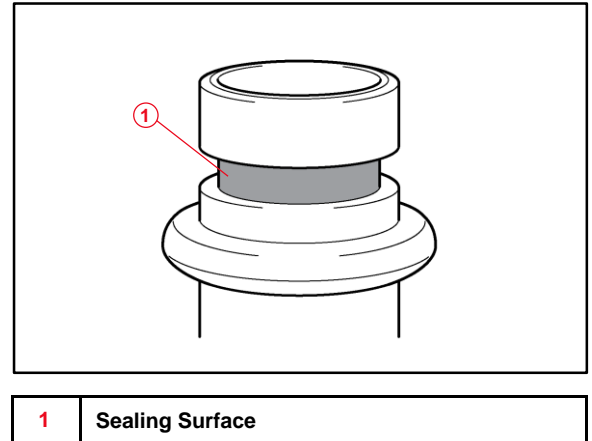

4. Inspect the ENTIRE sealing surface of the compressor making sure it is free from defects, such as foreign material adhesion, damage, or corrosion. If there are ANY defects, clean or replace the part. Refer to the [Sealing Surface Abnormalities \(Part Joint Area\)](#) subsection for judgement criteria.

NOTICE

When it is difficult to inspect the surface conditions due to oil adhesion, degrease the surface (such as by wiping it with a clean white cloth). Make sure NOT to lose any foreign material that was adhering to the surface that may indicate the source of the leak.

Figure 24.

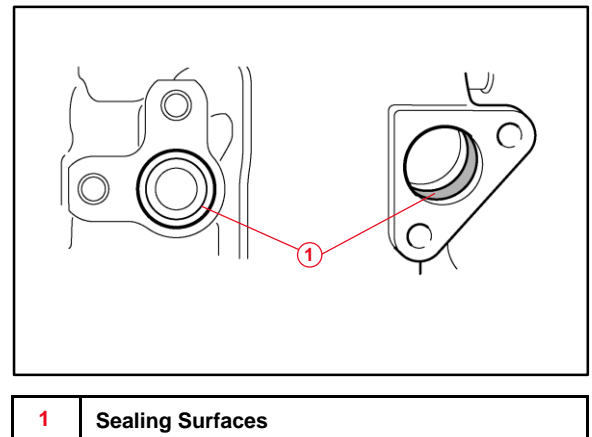

Air Conditioning Leak Detection Dye and O-ring Joint Inspection

HVAC O-ring Joint Inspections (continued)

Inspect Other Joint Areas

NOTICE

- Do NOT reuse the O-rings once they are removed.
- Make sure to inspect all the related parts and replace all the parts where defects are found.
- If no malfunction is found in ANY related parts, a temporary leak may have occurred due to foreign matter on an O-ring, deformation, etc.

1. Inspect the ENTIRE O-ring surface of the pipe or part making sure they are free from defects, such as damage (cuts, dents, or crushed areas), foreign material adhesion or twists. If there are ANY defects, clean or replace the part. Refer to the [O-ring Abnormalities](#) subsection for judgement criteria.

NOTICE

- Wipe off the joint area with a clean cloth before disassembly.
- Slowly remove the pipes straight to prevent the sealing face from being damaged and foreign materials from dropping off.

Figure 25.

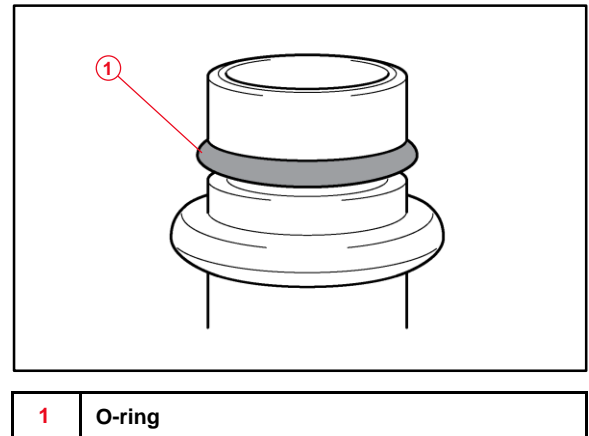

Air Conditioning Leak Detection Dye and O-ring Joint Inspection

HVAC O-ring Joint Inspections (continued)

Inspect Other Joint Areas (continued)

- Inspect the ENTIRE sealing surfaces of the pipe or part by removing the O-rings making sure they are free from defects, such as foreign material adhesion, damage, or corrosion. If there are ANY defects, clean or replace the pipe or part. Refer to the [Sealing Surface Abnormalities \(O-ring Attachment Area\)](#) subsection for judgement criteria.

NOTICE

When removing the O-rings, use soft tools (such as a toothpick) to avoid damaging the sealing face or the O-ring.

Figure 26.

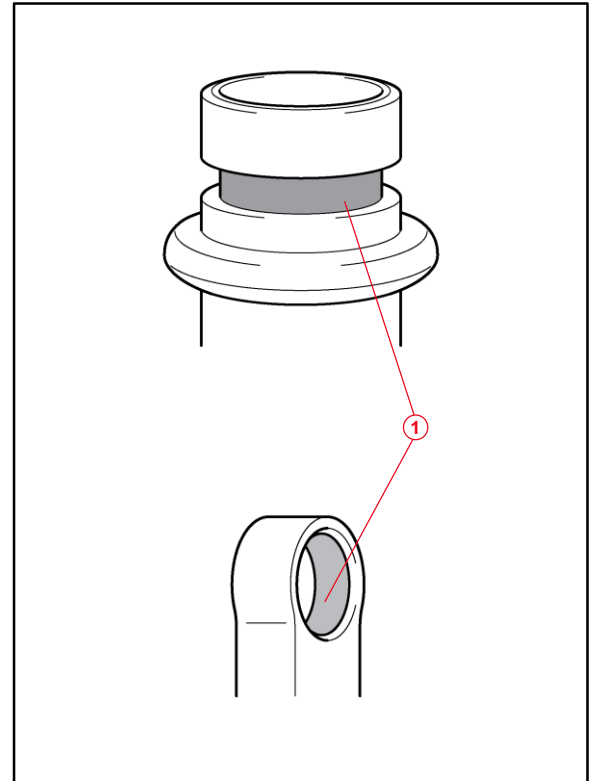









1	Sealing Surfaces
----------	-------------------------

Air Conditioning Leak Detection Dye and O-ring Joint Inspection

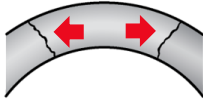
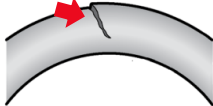
Judgement Criteria

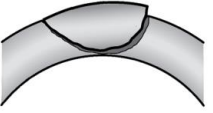
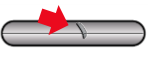
O-ring Abnormalities

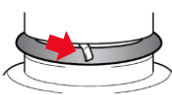
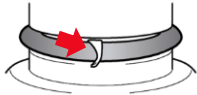
Table 2.

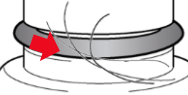
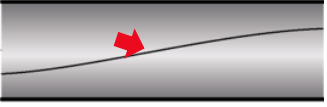

<p>OK CONDITION</p>	<p>There are NO cuts, dents, crushed areas, foreign materials, or twists.</p> 			
<p>CUT</p>				
<p>DENT / CRUSHED AREA</p>				
<p>FOREIGN MATERIAL</p>	<p>Metal Fragment</p> 	<p>Resin Fragment</p> 	<p>Lint</p> 	<p>Hair</p> 
<p>TWIST</p>				

Air Conditioning Leak Detection Dye and O-ring Joint Inspection

Judgement Criteria (continued)

Sealing Surface Abnormalities (O-ring Attachment Area)

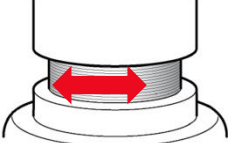
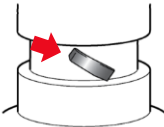
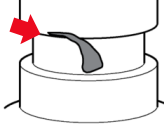
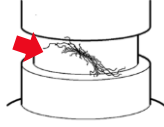
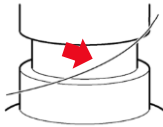
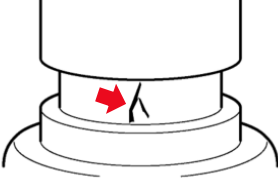
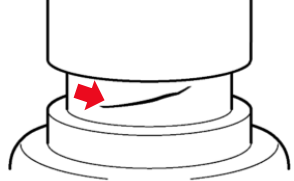
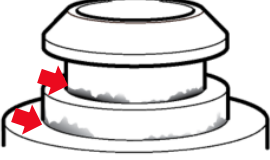
Table 3.

<p>OK CONDITION</p>	<p>Processing evidence in circumferential direction is NOT a cause of leakage.</p> 			
<p>FOREIGN MATERIAL</p>	<p>Metal Fragment</p> 	<p>Resin Fragment</p> 	<p>Lint</p> 	<p>Hair</p> 
<p>DAMAGE</p>				
<p>CORROSION</p>	<p>White and Yellow Materials Adhered (Corrosion Product)</p> 		<p>Damage (Scratches) in Axial Direction and Discoloration (Black)</p> 	

Air Conditioning Leak Detection Dye and O-ring Joint Inspection

Judgement Criteria (continued)

Sealing Surface Abnormalities (Part Joint Area)

Table 4.

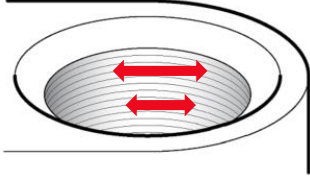
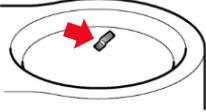
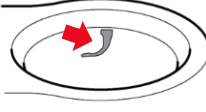
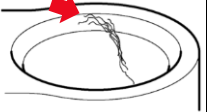
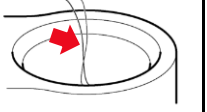
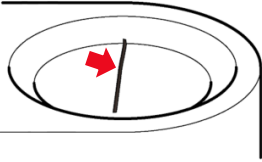
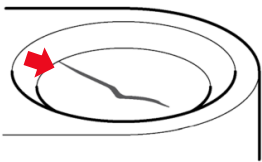
<p>OK CONDITION</p>	<p>Processing evidence in circumferential direction is NOT a cause of leakage.</p> 			
<p>FOREIGN MATERIAL</p>	<p>Metal Fragment</p> 	<p>Resin Fragment</p> 	<p>Lint</p> 	<p>Hair</p> 
<p>DAMAGE</p>				
<p>CORROSION</p>	<p>Uneven Discoloration (Black) on Sealing Surface</p> 