

Technical product information

Topic	Bentayga rear brake noise/squeal - Repair method depending on the brake noise frequency (Iron brakes only)
Market area	Australia E04 Bentley rest Asia and Australia (6E04),China 796 VW Import Comp. Ltd (Vico), Beijing (6796),Germany E02 Bentley rest Europe (6E02),Japan E03 Bentley Japan (6E03),Korea, (South) E08 Bentley South Korea (6E08),United Arab Emirates E06 Bentley Middle East and Africa (6E06),United Kingdom E01 Bentley UK (6E01),United States E05 Bentley USA and rest America (6E05)
Brand	Bentley
Transaction No.	2071730/1
Level	EH
Status	Approval
Release date	

New customer code

Object of complaint	Complaint type	Position
running gear -> brakes, brake control -> service brake	noise, vibration -> noise	

New workshop code

Object of complaint	Complaint type	Position
running gear -> brake system -> brake pads (disc brake)	noise, vibration -> noise	rear right
running gear -> brake system -> brake pads (disc brake)	noise, vibration -> noise	rear left

Vehicle data

Bentayga series

Sales types

Type	MY	Brand	Designation	Engine code	Gearbox code	Final drive code
4V1*	2017	E		*	*	*
4V1*	2018	E		*	*	*
4V1*	2019	E		*	*	*
4V1*	2020	E		*	*	*
4V1*	2021	E		*	*	*
4V1*	2022	E		*	*	*
4V1*	2023	E		*	*	*
4V1*	2024	E		*	*	*
ZV1*	2023	E		*	*	*
ZV1*	2024	E		*	*	*

Documents

Document name
master.xml
scenario1.docx
scenario2.docx
scenario3.docx

Customer statement / workshop findings

Brake noise/squeal from the rear brakes

Technical background

CAUTION

The operative MUST conduct the scenario which is evident depending on the symptom and frequency



Step 1 within the Measure section must be conducted to identify the symptom and frequency of the brake noise

Scenario 1

Vibration of 1.2 to 1.4 KHz is produced from the rear brakes whilst braking at low speed

Whilst braking at low speed, a vibration of 1.2 to 1.4 KHz or 5 KHz can be produced from friction between the rear brake pad and disc resulting in rear brake noise/squeal

Scenario 2

Vibration of 3.4 KHz is produced from the rear brakes

While braking at low speed a vibration of 3.4 KHz can be produced during brake application at low speed resulting in rear brake noise/squeal

Scenario 3

Vibration of 5 KHz is produced from the rear brakes whilst braking at low speed

Whilst braking at low speed, a vibration of 5 KHz can be produced from friction between the rear brake pad and disc resulting in rear brake noise/squeal

Production change

-

Measure



Step 1 must be conducted to identify the symptom and frequency of the brake noise

1) Carry out an inspection of the brake system to confirm the brake system components are serviceable as per Elsa pro guidelines

NOTICE

Refer to the Customer information section regarding exclusions from warranty and wear and tear service items

NOTICE

NOTICE: Rear brake pad replacement will be covered under warranty when conducting Scenario 3 only - No other Scenarios are applicable

2) Record the noise and frequency

Hint: For frequency analysis and noise recording we recommend using the Chassis Ear Tool **WT 10437**

The sound recording/video can also be taken from a mobile telephone as long as the noise/frequency is clearly identifiable

If the noise cannot be reproduced a customer recording of the noise is also acceptable as long as the noise/frequency is clearly identifiable

Hint: The operative can also refer to TPI 2052785/- for further guidelines regarding brake noise identification

- The operative MUST conduct the applicable scenario depending on the frequency of the noise



IMPORTANT: Prior to conducting any of the rework instructions, please ensure that all required information is attached to a new or existing DISS query including photographs and videos to support evidence of the brake noise complaint, failure to supply the requested information could result in the warranty claim being cancelled

Scenario 1 - Vibration of 1.2 to 1.4 KHz is produced from the rear brakes whilst braking at low speed

CAUTION

In the event the issue is evident post the following VIN's please raise a DISS query and await feedback before conducting any further work

Bentayga standard wheel base

Black Calliper - SJAA514VXPC018789

Red Calliper - SJAAT2ZV6PC018986

Bentayga extended wheel base

Black Calliper - SJAH514V0PC018914

Red Calliper - SJAHT2ZV2PC019003

However

In the event the issue is evident before the previously listed VIN's, please continue with the onward instructions

1) Remove the rear brake pads as per Repair manual Rep.Gr 46 - Rear Brake Pads - To Remove and Fit

- Check the condition of the brake pads

Hint: If the brake pads are to be refitted it will be necessary to make note of the original pad fitment position for installation purposes

- Fit the shim set **36A 698 219** to the rear brake pads (the kit consists of one shim per pad) and apply G052 560 A2 "Vary Bond Regular Grade Grease as detailed within the attached **Scenario 1 - Rear brake pad shim and grease application process**

CAUTION

VERY IMPORTANT: The application of the grease **MUST** be exactly as shown/detailed ensuring the exact amount of grease is applied to the locations shown

2) Once the grease and shims have been fitted - Clean the faces of the caliper carrier where the brake pads are in contact using a suitable brake cleaner

- Clean off any remaining dirt and brake dust which has accumulated using a suitable brake cleaner

3) Wipe the face of the piston to remove any brake dust or dirt

4) Refit the rear brake pads as per Rep.Gr 46 - Rear Brake Pads - To Remove and Fit, taking care not to dis-lodge the grease/shims before the pads are in position

5) Carry out a road test to confirm the noise is no longer evident

6) On return to the workshop, visually check and remove any excess grease which may have come out from between the shims

Scenario 2 - Vibration of 3.4 KHz is produced from the rear brakes

Fitment of rear brake calliper carriers for complaints relating to 3.4 KHz rear brake squeal



Left and right hand side orientation is referred to within this document

The left and right hand should be determined as viewed by the operative when standing on the underside of the vehicle and looking/facing towards the front of the vehicle

NOTE: Within the Rep.Gr procedures quoted within this document there are single use items which must be replaced and not reused. Ensure that new replacements are available prior to starting this procedure

1) Remove the left and right hand rear brake discs including the rear carriers as per Rep.Gr 46

Hint: The rear brake discs should be replaced in the event that the discs are not to specification as per Rep.Gr 46 - Brake discs - Checking condition and run-out (see note in the Warranty accounting instructions)

- Discard all previously removed parts as per all local environmental guidelines



Ensure all mating surfaces and brake components which are to be refitted (including rear brake callipers and the piston faces) are clean before reassembly

2) Referring to Rep.Gr 46 - Fit the left and right hand rear brake discs

3) Referring to Rep.Gr 46 - Fit the left and right hand rear carriers as follows:

Hint: There are two colours available (red and black) for photographic purposes only, black carriers are shown as follows:

Figure 1 and Figure 2 - Left hand side

Figure 3 and Figure 4 - Right hand side

Black

- 36A 698 425 - Left hand side
- 36A 698 426 - Right hand side

Red

- 36A 698 425 A - Left hand side
- 36A 698 426 A - Right hand side



Figure 1

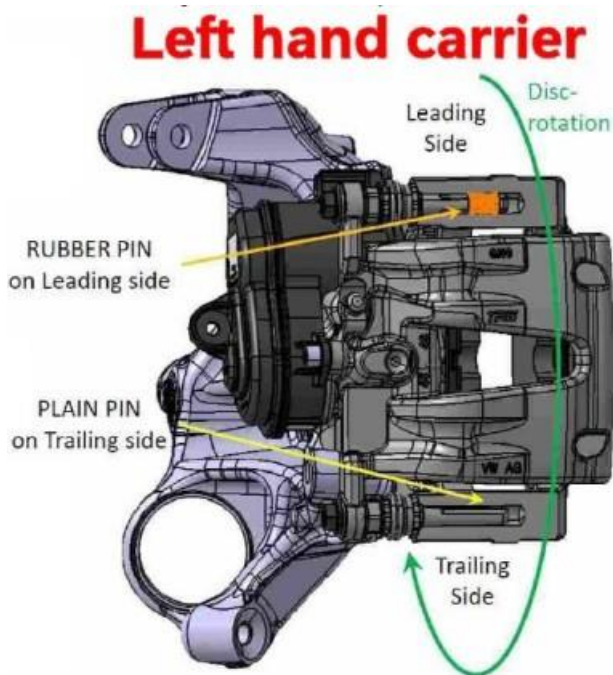

Figure 2



Figure 3

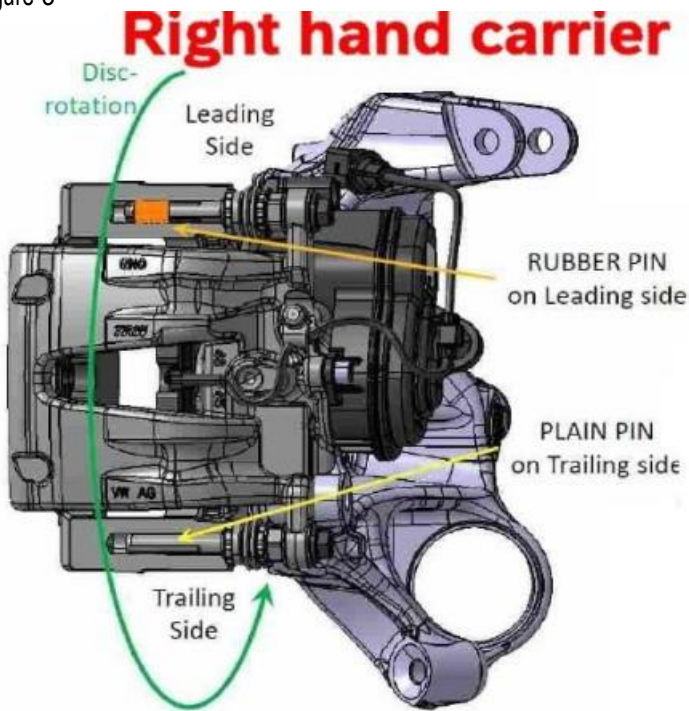

Figure 4



VERY IMPORTANT: Do not under any circumstances remove the rubber guide pins (Figure 5) from the new carriers as they have a predetermined level of grease applied that **MUST** not be disturbed

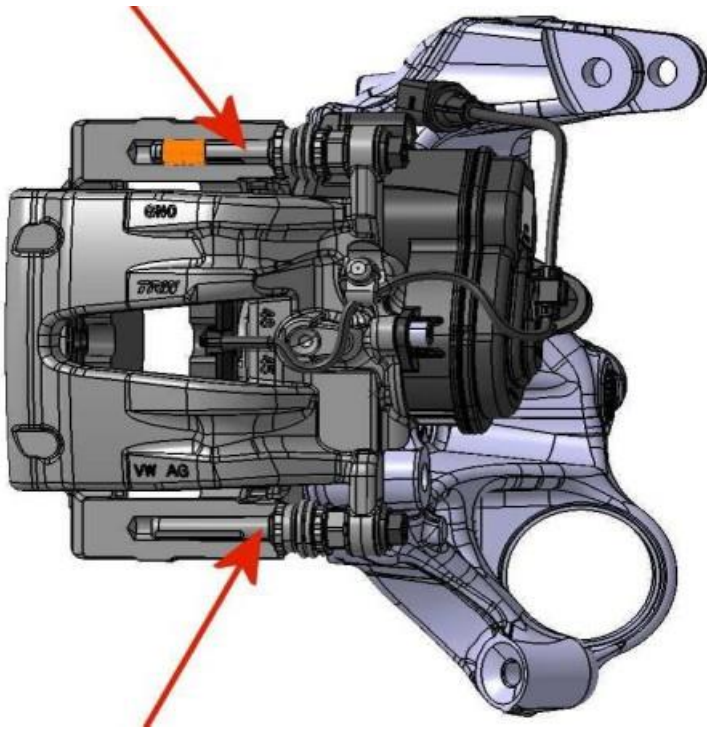

Figure 5

VERY IMPORTANT: Figure 6 shows the location in which the rubber pins should be positioned once the callipers have been fitted to specification

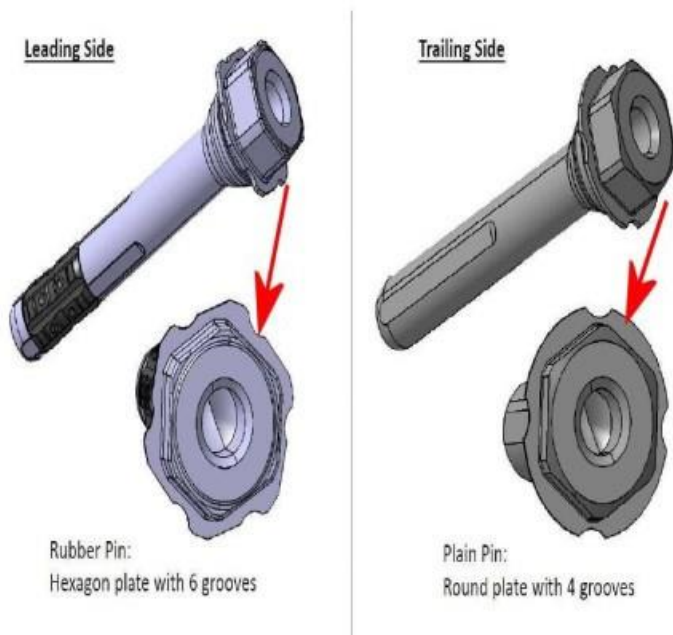

Figure 6

CAUTION

Only fit the shim set provided with the service kits to the rear brake pads and apply G052 560 A2 "Vary Bond Regular Grade Grease as detailed within the attached **Scenario 2 - Rear brake pad shim and grease application process**

CAUTION

VERY IMPORTANT: The application of the grease **MUST** be exactly as shown/detailed within the attached **Scenario 2 - Rear brake pad shim and grease application process** ensuring the exact amount of grease is applied to the locations shown

- 4) Once the grease and shims have been fitted - Clean the faces of the calliper carrier where the brake pads are in contact using a suitable brake cleaner
 - Clean off any remaining dirt and brake dust which has accumulated using a suitable brake cleaner
- 5) Wipe the face of the piston to remove any brake dust or dirt

- 6) Refit the rear brake pads as per Rep.Gr 46 - Rear Brake Pads - To Remove and Fit, taking care not to dis-lodge the grease/shims before the pads are in position
- 7) Carry out a road test to confirm the noise is no longer evident
- 8) On return to the workshop, visually check and remove any excess grease which may have come out from between the shims

Scenario 3 - Vibration of 5 KHz is produced from the rear brakes whilst braking at low speed

1) Confirm if the brake shim kit (36A 698 219) and grease has previously been fitted to the rear brake pads as per the attached **Scenario 3 - Rear brake pad shim and grease application process**

Yes - The shim kit is fitted - Continue from step 2

Or

No - The shim kit is not fitted - Fit the rear brake shim kit as described within the attached **Scenario 3 - Rear brake pad shim and grease application process once fitted continue from step 2**

- 2) Fit a new rear brake pad set
- 3) Clean the faces of the caliper carrier where the brake pads are in contact using a suitable brake cleaner
 - Clean off any remaining dirt and brake dust which has accumulated using a suitable brake cleaner
- 6) Wipe the face of the piston to remove any brake dust or dirt
- 7) Refit the rear brake pads as per Rep.Gr 46 - Rear Brake Pads - To Remove and Fit, taking care not to dis-lodge the grease/shims before the pads are fitted in position
- 8) Carry out a road test to confirm the noise is no longer evident
- 9) On return to the workshop, visually check and remove any excess grease which may have come out from between the shims

Warranty accounting instructions

For all Warranty accounting instructions please refer to the applicable attached rework instruction (Scenario 1, Scenario 2 and Scenario 3)

Exclusions from Warranty

Warranty claims are excluded in cases where the claim is directly related to the fact that:

- The customer failed to report the defect as soon as it became apparent or did not allow the required repairs to be carried out as soon as possible
- The fault was caused by outside influences, such as chemical or vegetation damage, flying gravel/stones, aggressive cleaning agents, etc
- The vehicle has been previously repaired without following Bentley Motors repair procedures
- Parts have been fitted to the vehicles that are not approved by Bentley Motors
- The customer has failed to follow the regulations for use of the vehicle
- The vehicle was overburdened or used for purposes for which it was not intended (e.g. racing, towing excessive loads, etc.)
- Natural wear and tear is excluded from the Warranty

Any rework which shows a lack of grease, or poor/incorrect application of grease and/or incorrect application of grease with extensive dirt on callipers or calliper carriers, for these scenarios warranty payment will not be considered

NOTE: Warranty payments for repeat repairs will not be considered if the grease is deemed to have not been applied correctly

All authorised Bentley Retailers must guarantee their workmanship for 12 months or 12,000 miles (19,300 kilometres), whichever occurs first

Wear and Tear and Service Items

Items where the lifetime of the component is or can be influenced by driving style and external factors (Brake pads and brake discs) will only be considered under the terms of the Warranty for a period of six months or 6,250 miles (10,060 kilometres), whichever occurs first. Beyond that limit, the defects must be classified as wear and tear and will not be covered by the Warranty

NOTICE

NOTICE: Rear brake pad replacement will be covered under warranty when conducting Scenario 3 only no other Scenarios are applicable

Parts information

For all Parts information please refer to the applicable attached rework instruction (Scenario 1, Scenario 2 and Scenario 3)

Scenario 1

Rear brake pad shim and grease application process - Vibration of 1.2 to 1.4 KHz

CAUTION

VERY IMPORTANT: The application of the grease MUST be exactly as shown/detailed ensuring the exact amount of grease is applied to the locations shown

1) Referring to Figure 1 - Apply 6 dots of grease (< 1.0g in total) to the inside face of the clip on each shim (x4 in total)



Figure 1

- Referring to Figure 2 - Using a suitable spatula spread the grease to an even layer condition (x4 shims in total)



Figure 2

2) Assemble the clip-on shim onto each pad

3) Once each shim has been assembled to each pad - Squeeze together firmly to remove any excess grease which comes out from between the new shim and the brake pad bonded shim



IMPORTANT: Ensure ALL excess grease is removed prior to fitting the brake pads

NOTE: Ensure the new shim is seated flat against the brake pad bonded shim

4) Referring to Figures 3 and 4 - Apply a small dot of grease to the pad abutments and the springs of each pad



Figure 3



Figure 4

- 5) Once the grease and shims have been fitted - Clean the faces of the caliper carrier where the brake pads are in contact using a suitable brake cleaner
 - Clean off any remaining dirt and brake dust which has accumulated using a suitable brake cleaner
- 6) Wipe the face of the piston to remove any brake dust or dirt
- 7) Refit the rear brake pads as per Rep.Gr 46 - Rear Brake Pads - To Remove and Fit, taking care not to dis-lodge the grease/shims before the pads are in position
- 8) Carry out a road test to confirm the noise is no longer evident
- 9) On return to the workshop, visually check and remove any excess grease which may have come out from between the shims

Warranty accounting instructions

Scenario 1

Warranty Type 110 or 910

Damage Service Number 46 38

Damage Code 00 20

Time to install shim set

Labour operation code 46 38 42 50

Time 20 TU

4 Brake pads - Rear - Removed and Refitted

Labour Operation Code 46 38 20 50

Time 50 Time units

2 Wheels Removed and Refitted

Labour Operation Code 44 05 20 00

Time 10 Time units

Frequency diagnosis including road test

Labour Operation Code 47 01 01 00

Time 80 Time units (includes road test 01 21 00 00 - 50 Time units)

Exclusions from Warranty

Warranty claims are excluded in cases where the claim is directly related to the fact that:

- The customer failed to report the defect as soon as it became apparent or did not allow the required repairs to be carried out as soon as possible
- The fault was caused by outside influences, such chemical or vegetation damage, flying gravel/stones, aggressive cleaning agents, etc
- The vehicle has been previously repaired without following Bentley Motors repair procedures
- Parts have been fitted to the vehicles that are not approved by Bentley Motors
- The customer has failed to follow the regulations for use of the vehicle
- The vehicle was overburdened or used for purposes for which it was not intended (e.g.racing, towing excessive loads, etc.)
- Natural wear and tear is excluded from the Warranty

Any rework which shows a lack of grease, or poor/incorrect application grease and/or incorrect application of grease with extensive dirt on callipers or calliper carriers, for these scenarios warranty payment will not be considered

NOTE: Warranty payments for repeat repairs will not be considered if the grease is deemed to have not been applied correctly

All authorised Bentley Retailers must guarantee their workmanship for 12 months or 12,000 miles (19,300 kilometres), whichever occurs first

Wear and Tear and Service Items

Items where the lifetime of the component is or can be influenced by driving style and external factors (Brake pads and brake discs) will only be considered under the terms of the Warranty for a period of six months or 6,250 miles (10,060 kilometres), whichever occurs first. Beyond that limit, the defects must be classified as wear and tear and will not be covered by the Warranty

Parts information

Scenario 1

Part number	Description	Quantity
36A 698 219	Shim set for rear brake pads	4 (see Notes below)
G 052 560 A2	Vary Bond grease	1 = 1 x 100 gram tube

Do not order x1 tube of grease for each individual vehicle as the grease must be used on multiple vehicles NOTE: x1 tube of grease should be sufficient for up to 15 vehicles

Should (x1) of 36A 698 219 be ordered the retailer will receive (x1) therefore the retailer MUST order x4 shims

The retailer MUST claim for the total amount of shims received

For example: If (x4) shims are ordered, the retailer will receive (4) shims. Therefore, the retailer must claim for (4)

Please note: The shims are reusable and can be transferred over to new brake pads when required

Tip: Before transferring the shims over to new brake pads, the shims must be cleaned and inspected to confirm there are no issues before fitment

Scenario 2

Rear brake pad shim and grease application process - Vibration of 3.4 KHz produced from the rear brakes

CAUTION

VERY IMPORTANT: The application of the grease MUST be exactly as shown/detailed ensuring the exact amount of grease is applied to the locations shown

1) Install one shim to each rear brake pad as detailed below



VERY IMPORTANT: Referring to Figure 1, the design of the shims (A and B) are different in appearance from the shims (C and D)

Hint: The shims listed above are supplied as part of the service kits as shown in the Parts information section of this TPI

2) Referring to Figure 1 - Apply 6 dots of grease (< 1.0g in total) to the inside face of the clip on each shim (x4 in total)

TIP: Grease application is the same process regardless of shim design



Figure 1

- Referring to Figure 2 - Using a suitable spatula spread the grease to an even layer condition (x4 shims in total)



Figure 2

3) Assemble the clip-on shim onto each pad, the pads **MUST** be fitted in the positions as detailed: below



VERY IMPORTANT: Referring to Figures 3,4,5 and 6, the design of the shims are different in appearance and must be fitted as detailed

1 - Left hand outer pad (Figure 3) - 36A 698 219



Figure 3

2 - Left hand inner pad (Figure 4) - 36A 698 219 A

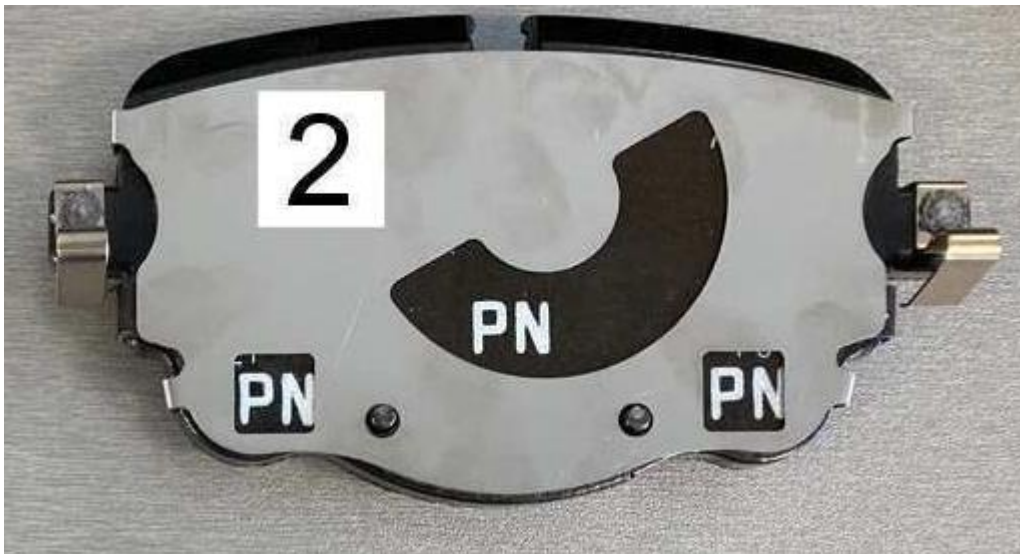

Figure 4

3 - Right hand inner pad (Figure 5) - 36A 698 219 B



Figure 5

4 - Right hand outer pad (Figure 6) - 36A 698 219



Figure 6

4) Once each shim has been assembled to each pad - Squeeze together firmly to remove any excess grease which comes out from between the new shim and the brake pad bonded shim



IMPORTANT: Ensure ALL excess grease is removed prior to fitting the brake pads

NOTE: Ensure the new shim is seated flat against the brake pad bonded shim

5) Referring to Figures 7 and 8 - Apply a small dot of grease to the pad abutments and the springs of each pad



Figure 7



Figure 8

- Wipe the face of the piston to remove any brake dust or dirt
- Refit the rear brake pads as per Repair manual Rep.Gr 46 - Rear Brake Pads - To Remove and Fit, taking care not to dis-lodge the grease/shims before the pads are in position

6) Once the brake pads has been refitted check to confirm the shims have been fitted correctly as detailed below



For clarity once fitted the brake pads MUST be positioned as shown in Figure 9 (with reference to Figures 3,4,5 and 6)



Figure 9

- 7) Carry out a road test to confirm the noise is no longer evident
- 8) On return to the workshop, visually check and remove any excess grease which may have come out from between the shims

Warranty accounting instructions

Scenario 2

Warranty Type 110 or 910

Damage Service Number 46 38

Damage Code 00 20

Time to install shim set

Labour operation code 46 38 42 50

Time 20 TU

4 Brake pads - Rear - Removed and Refitted

Labour Operation Code 46 38 20 50

Time 50 Time units

2 Wheels Removed and Refitted

Labour Operation Code 44 05 20 00

Time 10 Time units

Time to replace the left and right hand rear carriers

Labour operation code 46 15 19 50

Time 10 TU

Frequency diagnosis including road test

Labour Operation Code 47 01 01 00

Time 80 Time units (includes road test 01 21 00 00 - 50 Time units)

For all Warranty accounting instructions please refer to the applicable attached rework instruction (Scenario 1 or Scenario 2)

Exclusions from Warranty

Warranty claims are excluded in cases where the claim is directly related to the fact that:

- The customer failed to report the defect as soon as it became apparent or did not allow the required repairs to be carried out as soon as possible
- The fault was caused by outside influences, such chemical or vegetation damage, flying gravel/stones, aggressive cleaning agents, etc
- The vehicle has been previously repaired without following Bentley Motors repair procedures
- Parts have been fitted to the vehicles that are not approved by Bentley Motors
- The customer has failed to follow the regulations for use of the vehicle
- The vehicle was overburdened or used for purposes for which it was not intended (e.g.racing, towing excessive loads, etc.)
- Natural wear and tear is excluded from the Warranty

Any rework which shows a lack of grease, or poor/incorrect application grease and/or incorrect application of grease with extensive dirt on callipers or calliper carriers, for these scenarios warranty payment will not be considered

NOTE: Warranty payments for repeat repairs will not be considered if the grease is deemed to have not been applied correctly

All authorised Bentley Retailers must guarantee their workmanship for 12 months or 12,000 miles (19,300 kilometres), whichever occurs first

Wear and Tear and Service Items

Items where the lifetime of the component is or can be influenced by driving style and external factors (Brake pads and brake discs) will only be considered under the terms of the Warranty for a period of six months or 6,250 miles (10,060 kilometres), whichever occurs first. Beyond that limit, the defects must be classified as wear and tear and will not be covered by the Warranty

Parts information

Scenario 2

Part number	Description	Quantity
36A 698 147	Service kit (Black)	1
36A 698 147A	Service kit (Red)	1
G 052 560 A2	Vary Bond grease	1 = 1 x 100 gram tube
<i>Refer to ETKA (To be sourced by retailer)</i>	Carrier fixings	4
<i>Refer to ETKA (To be sourced by retailer)</i>	Carrier to Caliper fixings	4

Do not order x1 tube of grease for each individual vehicle as the grease must be used on multiple vehicles NOTE: x1 tube of grease should be sufficient for up to 15 vehicles

The service kit contains x1 left rear caliper carrier - x1 right rear caliper carrier and 4 brake pad shims with the following part numbers 36A 698 219A (x1) 36A 698 219B (x1) and 36A 698 219 (x2)

Please note: The shims are reusable and can be transferred over to new brake pads when required

Tip: Before transferring the shims over to new brake pads, the shims must be cleaned and inspected to confirm there are no issues before fitment

Scenario 3

Rear brake pad shim and grease application process - Vibration of 5 KHz

CAUTION

VERY IMPORTANT: The application of the grease MUST be exactly as shown/detailed ensuring the exact amount of grease is applied to the locations shown

1) Referring to Figure 1 - Apply 6 dots of grease (< 1.0g in total) to the inside face of the clip on each shim (x4 in total)



Figure 1

- Referring to Figure 2 - Using a suitable spatula spread the grease to an even layer condition (x4 shims in total)



Figure 2

2) Assemble the clip-on shim onto each pad

3) Once each shim has been assembled to each pad - Squeeze together firmly to remove any excess grease which comes out from between the new shim and the brake pad bonded shim



IMPORTANT: Ensure ALL excess grease is removed prior to fitting the brake pads

NOTE: Ensure the new shim is seated flat against the brake pad bonded shim

4) Referring to Figures 3 and 4 - Apply a small dot of grease to the pad abutments and the springs of each pad



Figure 3



Figure 4

- 5) Once the grease and shims have been fitted - Clean the faces of the calliper carrier where the brake pads are in contact using a suitable brake cleaner
 - Clean off any remaining dirt and brake dust which has accumulated using a suitable brake cleaner
- 6) Wipe the face of the piston to remove any brake dust or dirt
- 7) Refit the rear brake pads as per Rep.Gr 46 - Rear Brake Pads - To Remove and Fit, taking care not to dis-lodge the grease/shims before the pads are in position
- 8) Carry out a road test to confirm the noise is no longer evident
- 9) On return to the workshop, visually check and remove any excess grease which may have come out from between the shims

Warranty accounting instructions

Scenario 3

Warranty Type 110 or 910

Damage Service Number 46 38

Damage Code 00 20

Time to install shim set

Labour operation code 46 38 42 50

Time 20 TU

4 Brake pads - Rear - Replaced

Labour Operation Code 46 38 20 50

Time 50 Time units

Note: Rear brake pads can be claimed for this Scenario only

2 Wheels Removed and Refitted

Labour Operation Code 44 05 20 00

Time 10 Time units

Frequency diagnosis including road test

Labour Operation Code 47 01 01 00

Time 80 Time units (includes road test 01 21 00 00 - 50 Time units)

Exclusions from Warranty

Warranty claims are excluded in cases where the claim is directly related to the fact that:

- The customer failed to report the defect as soon as it became apparent or did not allow the required repairs to be carried out as soon as possible
- The fault was caused by outside influences, such chemical or vegetation damage, flying gravel/stones, aggressive cleaning agents, etc
- The vehicle has been previously repaired without following Bentley Motors repair procedures
- Parts have been fitted to the vehicles that are not approved by Bentley Motors
- The customer has failed to follow the regulations for use of the vehicle
- The vehicle was overburdened or used for purposes for which it was not intended (e.g.racing, towing excessive loads, etc.)
- Natural wear and tear is excluded from the Warranty

Any rework which shows a lack of grease, or poor/incorrect application grease and/or incorrect application of grease with extensive dirt on callipers or calliper carriers, for these scenarios warranty payment will not be considered

NOTE: Warranty payments for repeat repairs will not be considered if the grease is deemed to have not been applied correctly

All authorised Bentley Retailers must guarantee their workmanship for 12 months or 12,000 miles (19,300 kilometres), whichever occurs first

Wear and Tear and Service Items

Items where the lifetime of the component is or can be influenced by driving style and external factors (Brake pads and brake discs) will only be considered under the terms of the Warranty for a period of six months or 6,250 miles (10,060 kilometres), whichever occurs first. Beyond that limit, the defects must be classified as wear and tear and will not be covered by the Warranty

Parts information

Scenario 3

Part number	Description	Quantity
36A 698 219	Shim set for rear brake pads	4 (see Notes below)
G 052 560 A2	Vary Bond grease	1 = 1 x 100 gram tube
Refer to ETKA	Rear brake pads	1

Do not order x1 tube of grease for each individual vehicle as the grease must be used on multiple vehicles NOTE: x1 tube of grease should be sufficient for up to 15 vehicles

Should (x1) of 36A 698 219 be ordered the retailer will receive (x1) therefore the retailer MUST order x4 shims

The retailer MUST claim for the total amount of shims received

For example: If (x4) shims are ordered, the retailer will receive (4) shims. Therefore, the retailer must claim for (4)

Please note: The shims are reusable and can be transferred over to new brake pads when required

Tip: Before transferring the shims over to new brake pads, the shims must be cleaned and inspected to confirm there are no issues before fitment

NOTICE: Rear brake pad replacement will be covered under warranty when conducting Scenario 3 only no other Scenarios are applicable