



Technical Service Bulletin

SUBJECT: STEERING WHEEL SENSOR CALIBRATION - SERVICE MANUAL REVISION			No: TSB-23-35-004
			DATE: November 2023
			MODEL: See below
CIRCULATE TO:	<input type="checkbox"/> GENERAL MANAGER	<input checked="" type="checkbox"/> PARTS MANAGER	<input checked="" type="checkbox"/> TECHNICIAN
<input checked="" type="checkbox"/> SERVICE ADVISOR	<input checked="" type="checkbox"/> SERVICE MANAGER	<input checked="" type="checkbox"/> WARRANTY PROCESSOR	<input checked="" type="checkbox"/> SALES MANAGER

PURPOSE

This TSB details corrections to the Active Stability Control System, On Vehicle Service section of the applicable Service Manual.

AFFECTED VEHICLES

2012-2014 i-MiEV
2016-2017 i-MiEV

AFFECTED SERVICE MANUAL

2012-2014 i-MiEV Service Manual
2016-2017* i-MiEV Service Manual

PROCEDURE

Please use the chart below to replace the applicable pages in the affected Service Manual, Group 35, Active Stability Control System, On Vehicle Service, Steering Wheel Sensor Calibration section.

Applicable Manual	Pub. No.	Applicable Title	Content
2012 i-MiEV Service Manual	MSCD-018B-2012	STEERING WHEEL SENSOR CALIBRATION	Attached sheet 5
2013 i-MiEV Service Manual	MSCD-018B-2013	STEERING WHEEL SENSOR CALIBRATION (M355-00-920-31600-01)	Attached sheet 6
2014 i-MiEV Service Manual	MSCD-018B-2014		
2016 i-MiEV Service Manual	MSCD-018B-2016	STEERING WHEEL SENSOR CALIBRATION (M355-00-920-31600-01)	Attached sheet 7
2017 i-MiEV Service Manual	MSCD-018B-2016*		

*For 2017 MY vehicles, refer to 2016 i-MiEV Service Manual

Copyright 2023, Mitsubishi Motors North America, Inc.

The information contained in this bulletin is subject to change. For the latest version of this document, go to the Mitsubishi Dealer Link, MEDIC, or the Mitsubishi Service Information website (www.mitsubishitechinfo.com).

IN THE EVENT OF A DISCHARGED AUXILIARY BATTERY

M1355006200221

⚠ WARNING

If the ASC is not operating, the vehicle will be unstable during braking, Do not drive the vehicle with the ASC-ECU connector disconnected or with the ASC not operating.

If the electric motor unit is started using a booster cable when the auxiliary battery is completely flat,

and the vehicle is then driven without waiting for the auxiliary battery to be recharged, the electric motor unit may misfire and it may not be possible to drive the vehicle. This is because the ASC consumes a large amount of current when carrying out its initial checks. If this happens, recharge the auxiliary battery fully.

<Correct>

update the neutral position stored in the steering wheel sensor.

M1355009200316

STEERING WHEEL SENSOR CALIBRATION

⚠ CAUTION

After the next operation has been completed, carry out the following two operations:

- Alignment adjustment <Front> <Incorrect>
 - Steering wheel sensor (column switch assembly) replacement, removal, installation <Deleted>
1. ~~Update the neutral position stored in the steering wheel sensor.~~
 2. ~~Reset the calibrated value of the steering angle stored in ASC-ECU.~~

⚠ CAUTION

- ~~Before performing the calibration, check if the steering wheel sensor-related DTC is set in ASC-ECU.~~

<Deleted>

- When the DTC other than C1394 is set, carry out the inspection according to each troubleshooting procedure.

1. Park the vehicle on a level surface with tires and steering wheel positioned in a straight ahead direction.
2. Turn the electric motor switch to the "ON" position.
3. Turn the electric motor switch to the "LOCK" (OFF) position.

⚠ CAUTION

Before connecting or disconnecting scan tool, always turn the electric motor switch to the LOCK (OFF) position.

4. Check that the electric motor switch is in the "LOCK" (OFF) position, and then set scan tool.
5. Turn the electric motor switch to the "ON" position.
6. On the Menu, select "System selection."
7. In "System table" of "System selection," select "Steering angle sensor," and then press the "OK" button.
8. In "Steering angle sensor," select "Special function."

9. In "Special function," select "Learn neutral position of steering angle sensor."

NOTE: When the neutral position of steering angle sensor has been learned, "Neutral position learned already: in order to relearn the neutral position, press the "OK" button to initialize the steering angle sensor neutral position." is displayed. If it is okay, press the "OK" button.

10. In "Learn neutral position of steering angle sensor," "Initialize neutral position of steering angle sensor" is selected, thus press the "OK" button.

NOTE: When the neutral position of steering angle sensor has been learned, "Initialize neutral position of steering angle sensor: Do you want to execute? Note: The DTC will be erased." is displayed. Then, press the "OK" button.

11. "Initialize neutral position of steering angle sensor: Completed" is displayed. Then, press the "OK" button.
12. Press the "OK" button.
13. "Learn neutral position of steering angle sensor: Do you want to execute? Note: Execute after the tires and steering wheel are aligned in a straight ahead direction." is displayed. Then, press the "OK" button.
14. "Learn neutral position of steering angle sensor: Completed" is displayed. Then, press the "OK" button.
15. After turning the electric motor switch to "LOCK" (OFF) position, turn it to the "ON" position again.

16. On the Menu, select "System selection."
17. On the "System selection," select "ABS/ASC/ASTC" in the "System table," and then click the "OK" button.
18. In the "ABS/ASC/ASTC" field, select "Special function".
19. In the "Special function," select "Learn sensor neutral position."

<Deleted>

~~20. In "Learn sensor neutral position," select "Learn neutral position of steering angle sensor," and then press the "OK" button.~~

~~21. "Learn neutral position of steering angle sensor: Are you sure to execute the selected item? Note: Check the execution conditions." is displayed. Then, press the "OK" button.~~

<Deleted>

~~22. "Execute command: Executed" is displayed. Then, press the "OK" button.~~

~~23. The neutral point is learned.~~

<Deleted>

~~24. Turn the electric motor switch to the "LOCK" (OFF) position, and remove scan tool from the vehicle.~~

16.

17. <Changed>

ASC OFF SWITCH

REMOVAL AND INSTALLATION

M1357003300043

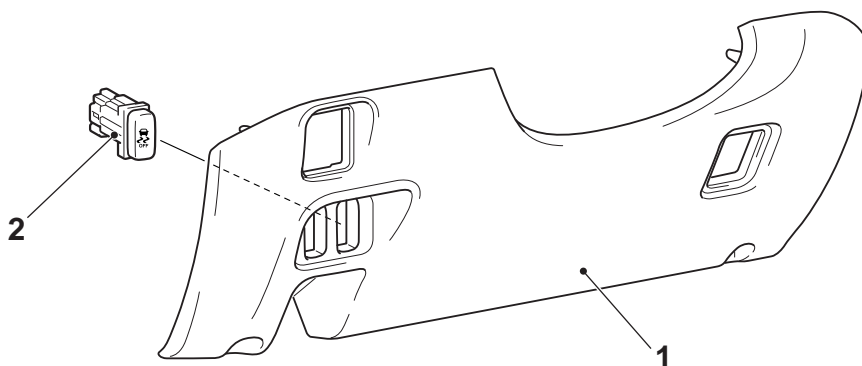

ACA02711AB

Removal steps

- Under cover (Refer to GROUP 52A – Instrument Panel Assembly.)
- ASC OFF switch

INSPECTION

M1357004600014

ASC OFF SWITCH CONTINUITY CHECK

- As shown in the figure, connect the circuit tester to the ASC OFF switch as a single unit.
- Check the continuity status when the ASC OFF switch is pressed and when the switch is released.

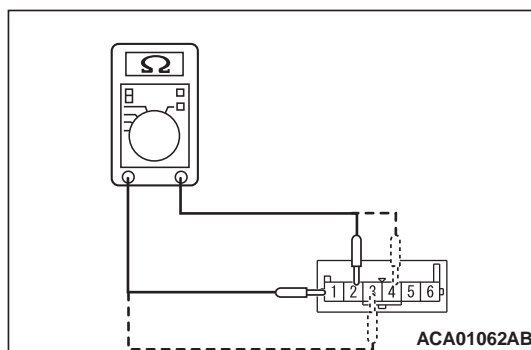

ACA01062AB

Item	When the ASC OFF switch is released (Not being operated)	When the ASC OFF switch is pressed
Continuity between terminal No. 1 and No. 2	No continuity	Continuity exists (2 Ω or less)
Continuity between terminal No. 3 and No. 4	Continuity exists	Continuity exists

IN THE EVENT OF A DISCHARGED 12V STATER BATTERY

M1355006200221

⚠ WARNING

If the ASC is not operating, the vehicle will be unstable during braking, Do not drive the vehicle with the ASC-ECU connector disconnected or with the ASC not operating.

If the electric motor unit is started using a booster cable when the 12V Stater battery is completely flat, and the vehicle is then driven without waiting for the 12V Stater battery to be recharged, the electric motor unit may misfire and it may not be possible to drive the vehicle. This is because the ASC consumes a large amount of current when carrying out its initial checks. If this happens, recharge the 12V Stater battery fully.

STEERING WHEEL SENSOR CALIBRATION

⚠ CAUTION

After the next operation has been completed, carry out the following two operations:

- Alignment adjustment <Front> <Incorrect>
- Steering wheel sensor (column switch assembly) replacement, removal, installation <Deleted>

- ~~1. Update the neutral position stored in the steering wheel sensor.~~
- ~~2. Reset the calibrated value of the steering angle stored in ASC-ECU.~~

⚠ CAUTION

- ~~Before performing the calibration, check if the steering wheel sensor-related DTC is set in ASC-ECU.~~ <Deleted>
- When the DTC other than C1394 is set, carry out the inspection according to each troubleshooting procedure.

1. Park the vehicle on a level surface with tires and steering wheel positioned in a straight ahead direction.
2. Turn the electric motor switch to the "ON" position.
3. Turn the electric motor switch to the "LOCK" (OFF) position.

⚠ CAUTION

Before connecting or disconnecting scan tool, always turn the electric motor switch to the LOCK (OFF) position.

4. Check that the electric motor switch is in the "LOCK" (OFF) position, and then set scan tool.
5. Turn the electric motor switch to the "ON" position.
6. On the Menu, select "System selection."

<Correct>

update the neutral position stored in the steering wheel sensor.

M1355009200316

7. In "System table" of "System selection," select "Steering angle sensor," and then press the "OK" button.
8. In "Steering angle sensor," select "Special function."
9. In "Special function," select "Learn neutral position of steering angle sensor."

NOTE: When the neutral position of steering angle sensor has been learned, "Neutral position learned already: in order to relearn the neutral position, press the "OK" button to initialize the steering angle sensor neutral position." is displayed. If it is okay, press the "OK" button.

10. In "Learn neutral position of steering angle sensor," "Initialize neutral position of steering angle sensor" is selected, thus press the "OK" button.

NOTE: When the neutral position of steering angle sensor has been learned, "Initialize neutral position of steering angle sensor: Do you want to execute? Note: The DTC will be erased." is displayed. Then, press the "OK" button.

11. "Initialize neutral position of steering angle sensor: Completed" is displayed. Then, press the "OK" button.
12. Press the "OK" button.
13. "Learn neutral position of steering angle sensor: Do you want to execute? Note: Execute after the tires and steering wheel are aligned in a straight ahead direction." is displayed. Then, press the "OK" button.
14. "Learn neutral position of steering angle sensor: Completed" is displayed. Then, press the "OK" button.

15. After turning the electric motor switch to "LOCK" (OFF) position, turn it to the "ON" position again.

16. On the Menu, select "System selection."

17. On the "System selection," select "ABS/ASC/ASTC" in the "System table," and then click the "OK" button.

18. In the "ABS/ASC/ASTC" field, select "Special function".

19. In the "Special function," select "Learn sensor neutral position."

<Deleted>

20. In "Learn sensor neutral position," select "Learn neutral position of steering angle sensor," and then press the "OK" button.

21. "Learn neutral position of steering angle sensor: Are you sure to execute the selected item? Note: Check the execution conditions." is displayed. Then, press the "OK" button.

22. "Execute command: Executed" is displayed. Then, press the "OK" button.

23. The neutral point is learned.

<Deleted>

24. Turn the electric motor switch to the "LOCK" (OFF) position, and remove scan tool from the vehicle.

<Changed>

16.

17.

ASC OFF SWITCH

REMOVAL AND INSTALLATION

M1357003300043

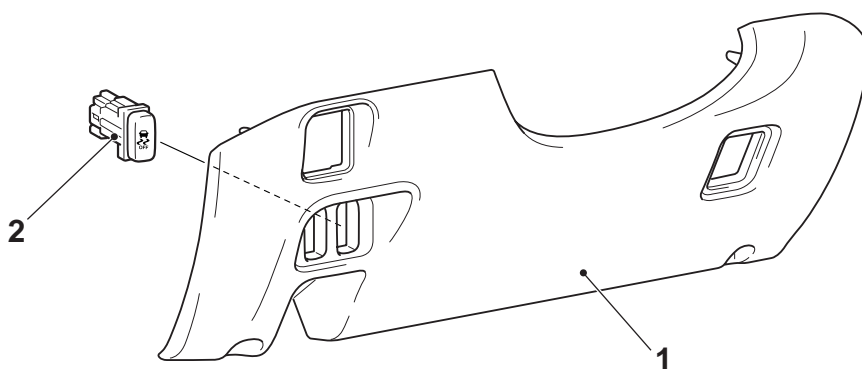

ACA02711AB

Removal steps

1. Under cover (Refer to GROUP 52A - Instrument Panel Assembly.)
2. ASC OFF switch

INSPECTION

M1357004600014

ASC OFF SWITCH CONTINUITY CHECK

1. As shown in the figure, connect the circuit tester to the ASC OFF switch as a single unit.
2. Check the continuity status when the ASC OFF switch is pressed and when the switch is released.

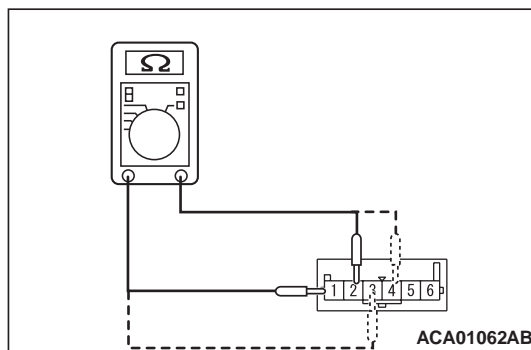

IN THE EVENT OF A DISCHARGED 12V STARTER BATTERY

M1355006200287

⚠ WARNING

If the ASC is not operating, the vehicle will be unstable during braking, Do not drive the vehicle with the ASC-ECU connector disconnected or with the ASC not operating.

If the electric motor unit is started using a booster cable when the 12V Starter battery is completely flat, and the vehicle is then driven without waiting for the 12V Starter battery to be recharged, the electric motor unit may misfire and it may not be possible to drive the vehicle. This is because the ASC consumes a large amount of current when carrying out its initial checks. If this happens, recharge the 12V Starter battery fully.

STEERING WHEEL SENSOR CALIBRATION**⚠ CAUTION**

After the next operation has been completed, ~~carry out the following two operations:~~

- Alignment adjustment <Front> ~~<Incorrect>~~
- Steering wheel sensor (column switch assembly) replacement, removal, installation ~~<Deleted>~~

1. ~~Update the neutral position stored in the steering wheel sensor.~~
2. ~~Reset the calibrated value of the steering angle stored in ASC-ECU.~~

⚠ CAUTION

- ~~Before performing the calibration, check if the steering wheel sensor-related DTC is set in ASC-ECU.~~ ~~<Deleted>~~
- When the DTC other than C1394 is set, carry out the inspection according to each troubleshooting procedure.

1. Park the vehicle on a level surface with tires and steering wheel positioned in a straight ahead direction.
2. Turn the electric motor switch to the "ON" position.
3. Turn the electric motor switch to the "LOCK" (OFF) position.

⚠ CAUTION

Before connecting or disconnecting scan tool, always turn the electric motor switch to the LOCK (OFF) position.

4. Check that the electric motor switch is in the "LOCK" (OFF) position, and then set scan tool.
5. Turn the electric motor switch to the "ON" position.
6. On the Menu, select "System selection."

<Correct>

update the neutral position stored in the steering wheel sensor.

M1355009200316

7. In "System table" of "System selection," select "Steering angle sensor," and then press the "OK" button.
8. In "Steering angle sensor," select "Special function."
9. In "Special function," select "Learn neutral position of steering angle sensor."
NOTE: When the neutral position of steering angle sensor has been learned, "Neutral position learned already: in order to relearn the neutral position, press the "OK" button to initialize the steering angle sensor neutral position." is displayed. If it is okay, press the "OK" button.
10. In "Learn neutral position of steering angle sensor," "Initialize neutral position of steering angle sensor" is selected, thus press the "OK" button.
NOTE: When the neutral position of steering angle sensor has been learned, "Initialize neutral position of steering angle sensor: Do you want to execute? Note: The DTC will be erased." is displayed. Then, press the "OK" button.
11. "Initialize neutral position of steering angle sensor: Completed" is displayed. Then, press the "OK" button.
12. Press the "OK" button.
13. "Learn neutral position of steering angle sensor: Do you want to execute? Note: Execute after the tires and steering wheel are aligned in a straight ahead direction." is displayed. Then, press the "OK" button.
14. "Learn neutral position of steering angle sensor: Completed" is displayed. Then, press the "OK" button.

ACTIVE STABILITY CONTROL SYSTEM (ASC) ASC OFF SWITCH

35C-141

15. After turning the electric motor switch to "LOCK" (OFF) position, turn it to the "ON" position again.

16. On the Menu, select "System selection."

17. On the "System selection," select "ABS/ASC/ASTC" in the "System table," and then click the "OK" button.

18. In the "ABS/ASC/ASTC" field, select "Special function".

19. In the "Special function," select "Learn sensor neutral position."

<Deleted>

20. In "Learn sensor neutral position," select "Learn neutral position of steering angle sensor," and then press the "OK" button.

21. "Learn neutral position of steering angle sensor: Are you sure to execute the selected item? Note: Check the execution conditions." is displayed. Then, press the "OK" button.

22. "Execute command: Executed" is displayed. Then, press the "OK" button.

23. The neutral point is learned. <Deleted>

24. Turn the electric motor switch to the "LOCK" (OFF) position, and remove scan tool from the vehicle.

<Changed>

16.

17.

ASC OFF SWITCH

REMOVAL AND INSTALLATION

M1357003300043

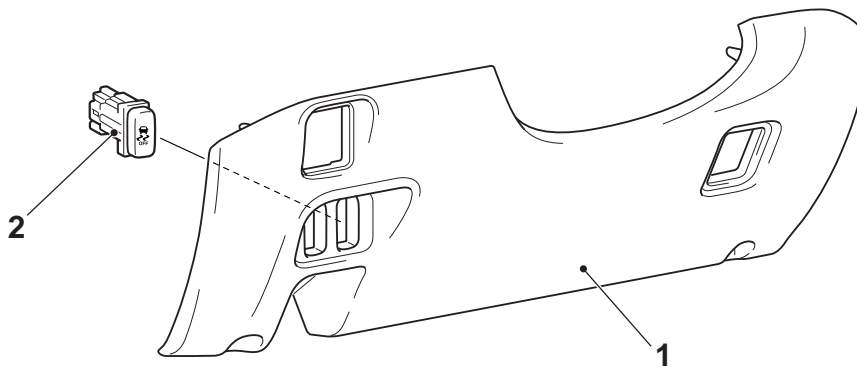

ACA02711AB

Removal steps

1. Under cover (Refer to GROUP 52A – Instrument Panel Assembly .)
2. ASC OFF switch

INSPECTION

M1357004600014

ASC OFF SWITCH CONTINUITY CHECK

1. As shown in the figure, connect the circuit tester to the ASC OFF switch as a single unit.
2. Check the continuity status when the ASC OFF switch is pressed and when the switch is released.

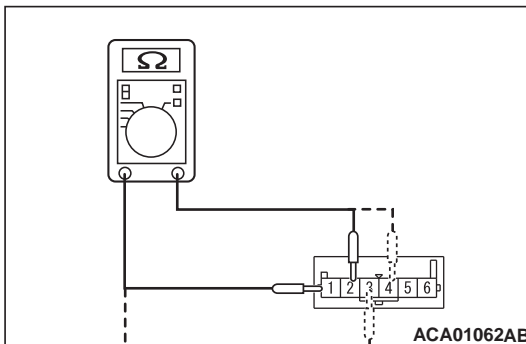

ACA01062AB