



I N F I N I T I

Nissan Group of the Americas  
Copyright ©

# TECHNICAL SERVICE BULLETIN

Classification: FA21-010B	Reference: ITB21-023B	Date: December 13, 2023
------------------------------	--------------------------	----------------------------

## TRANSFER ASSEMBLY SEAL REPLACEMENT FOR AWD FRONT DRIVE SHAFT REMOVAL

This bulletin has been amended. See AMENDMENT HISTORY on the last page.  
Please discard previous versions of this bulletin.

**APPLIED VEHICLES:** 2019-2024 QX50 (J55)  
2022-2024 QX55 (FJ55)  
2014-2020 QX60 (L50)  
2014 QX60 Hybrid (L50H)

**APPLIED DRIVELINES:** AWD only

### SERVICE INFORMATION

When removing the front passenger (RH) side drive shaft on an **APPLIED VEHICLE** for any reason, transfer assembly drive shaft oil seal and dust cover seal replacement is required.

- Refer to the **SERVICE PROCEDURE** in this bulletin for transfer assembly drive shaft oil seal and dust cover seal replacement.
- Refer to the **ESM** and ITB17-001 for additional **SERVICE INFORMATION** regarding front passenger (RH) side drive shaft removal and installation.
- **DO NOT REPLACE** the transfer assembly.
  - This repair does NOT require transfer assembly removal from the vehicle.
  - This repair does NOT require transfer cover removal from the transfer assembly.
  - When replacing the drive shaft oil seal and the dust seal on 2019-2024 QX50 and 2022-2024 QX55 vehicles, it is recommended to remove the drive shaft support bearing bracket for additional clearance.

Infiniti Bulletins are intended for use by qualified technicians, not 'do-it-yourselfers'. Qualified technicians are properly trained individuals who have the equipment, tools, safety instruction, and know-how to do a job properly and safely. **NOTE:** If you believe that a described condition may apply to a particular vehicle, DO NOT assume that it does. See your Infiniti retailer to determine if this applies to your vehicle.

**REQUIRED SPECIAL TOOL(S)**

New or replacement Essential Tools are available from Tech•Mate online: [www.techmatetools.com](http://www.techmatetools.com), or by phone: 1-833-397-3493.

When ordering, keep in mind that the tool part number prefix has changed from "J" to "NI". For example, J-52469-1 is now NI-52469-1.



Figure 1

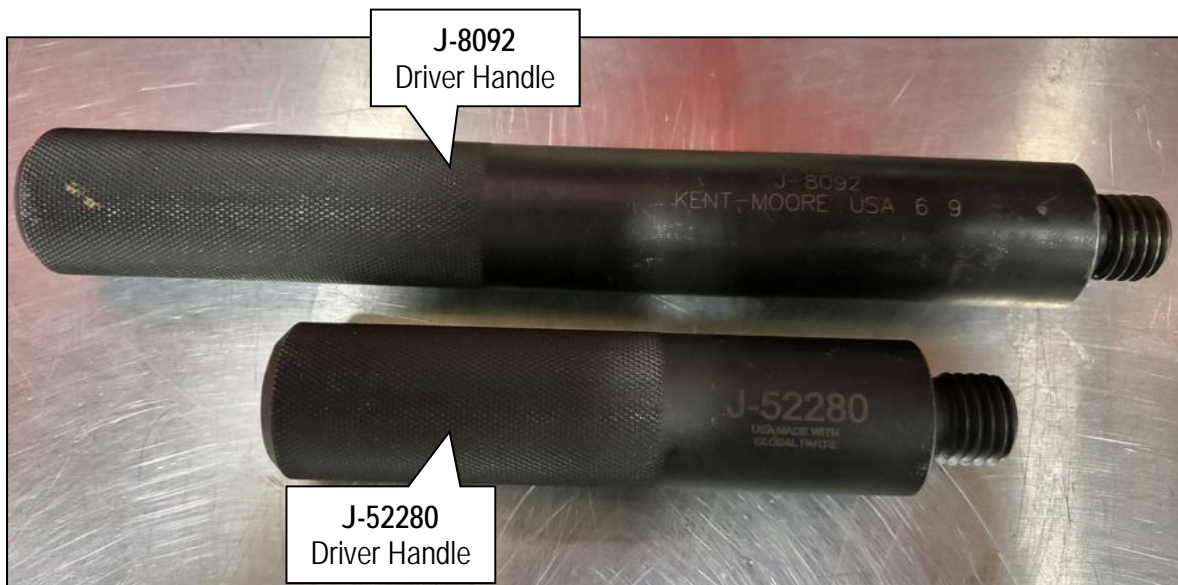

Figure 2

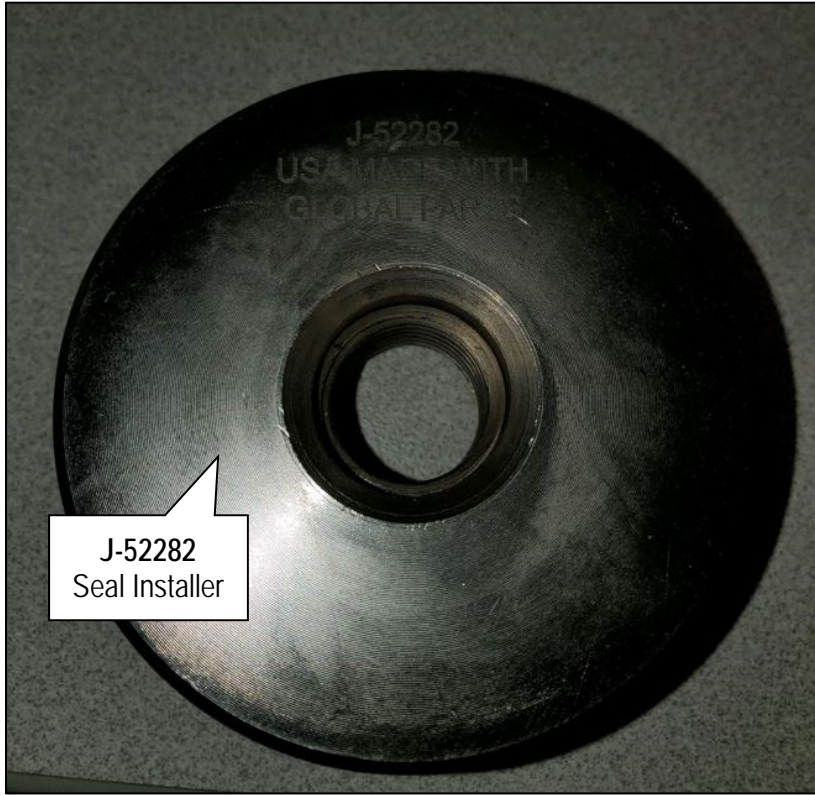

Figure 3



Figure 4

## SERVICE PROCEDURE

### NOTICE

- To avoid leak recurrence and damage to the transfer assembly, use care when removing the dust cover seal and the drive shaft oil seal.
- To avoid damage to the transfer assembly and new seals, use an appropriate seal installer and seal protector during the repair.

1. Using a suitable tool, remove the dust cover seal (not shown).
  - Discard the dust cover seal, it will not be reused.
2. Using a suitable tool, remove the drive shaft oil seal (Figure 5).
  - Discard the drive shaft oil seal, it will not be reused.

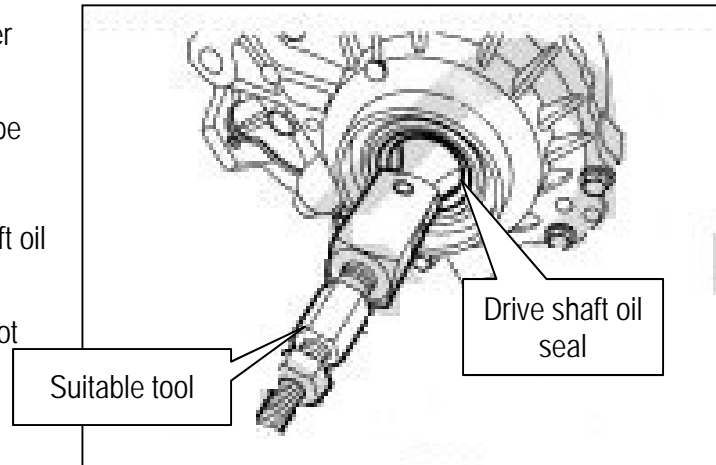

Figure 5

### NOTICE

To avoid damage to the new dust cover seal and the new drive shaft oil seal, lubricate the seal lips before installation.

3. Install the new drive shaft oil seal.
  - a. Install the new drive shaft oil seal onto Seal Installer J-52390 (Figure 6).

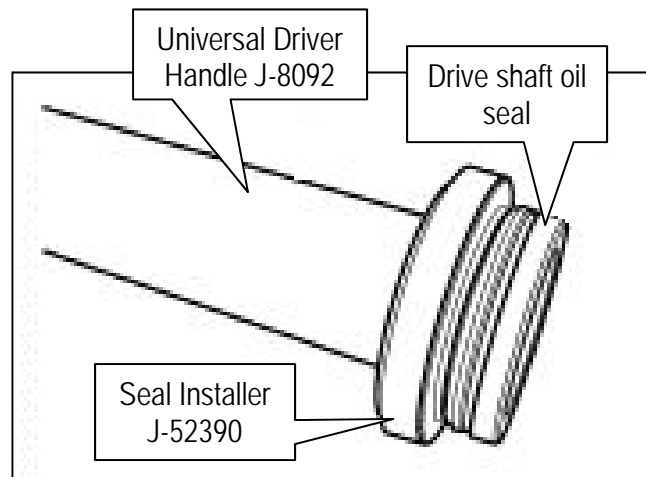

Figure 6

- b. With the help of an assistant, install the new drive shaft oil seal into the transfer assembly to the specified depth of 2.0-2.6 mm (0.079-0.102 in.) using Universal Driver Handle J-8092 and Seal Installer J-52390 (Figure 7).

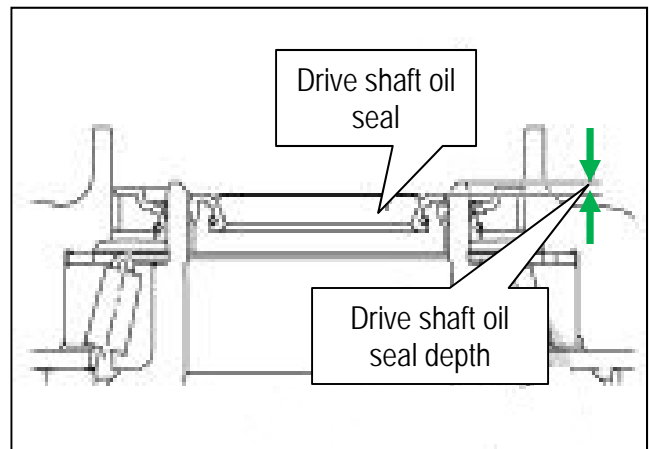

Figure 7

4. Install the new dust cover seal.

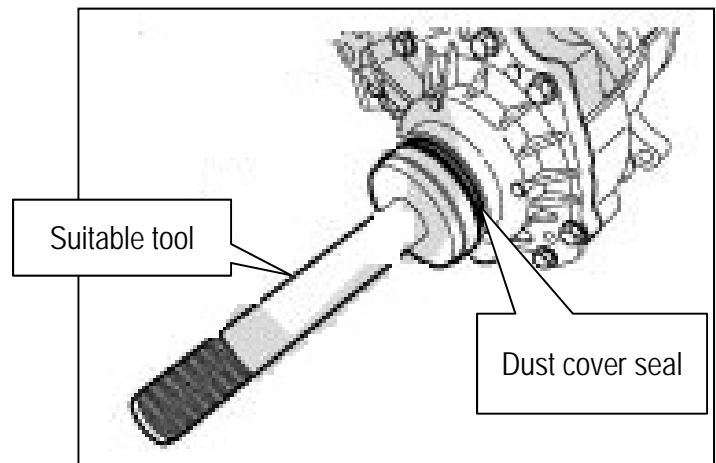

Figure 8

- a. With the help of an assistant, install the new dust cover seal to the specified depth of 0.0-0.6 mm (0.000-0.024 in.) using a suitable tool (Figure 8 and Figure 9).

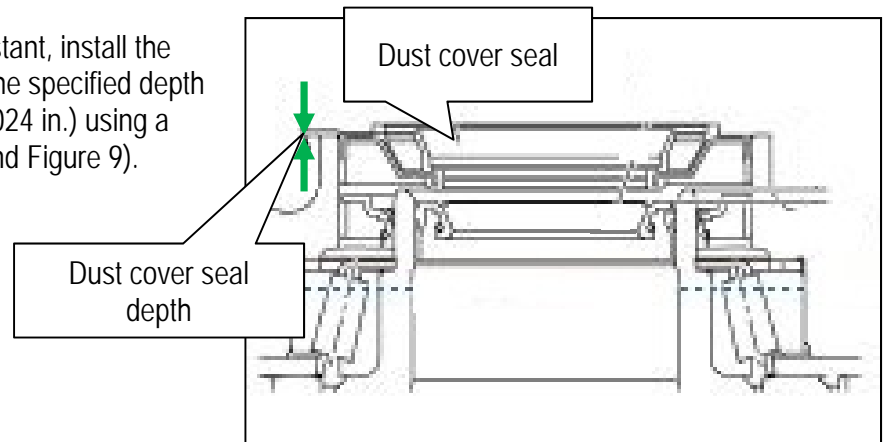

Figure 9



## Drive Shaft Support Bracket Installation Recommendations (2019-2024 QX50 and 2022-2024 QX55)

### NOTICE

To avoid leak recurrence and damage to the transfer assembly and new seals, follow the sequence below on 2019-2024 QX50 and 2022-2024 QX55 vehicles for drive shaft support bearing bracket installation.

1. Place and hold the drive shaft support bearing bracket into position, ensuring it is flat against the engine block and flat against the transfer assembly and loosely install the bolts (Figure 10).

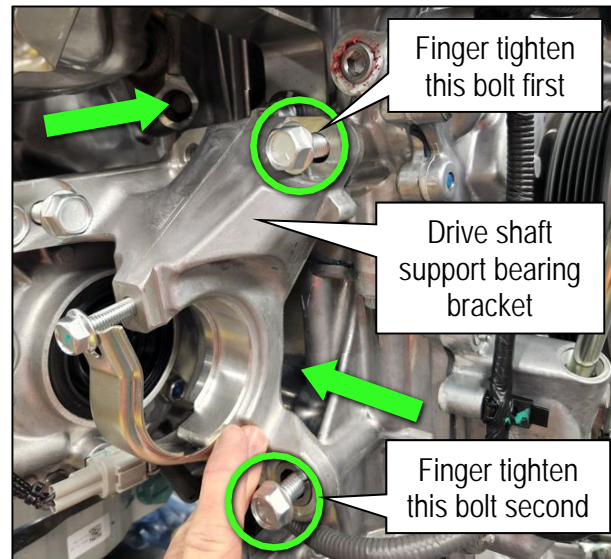

Figure 10

2. While continuing to hold the drive shaft support bearing bracket into position, finger tighten the top drive shaft support bearing bracket to engine block bolt first, and then finger tighten the lower drive shaft support bearing bracket to engine block bolt.
3. Finger tighten the drive shaft support bearing bracket to transfer assembly bolts.

4. While continuing to hold the drive shaft support bearing bracket into position, torque the top drive shaft support bearing bracket to engine block bolt to specification first, and then torque the lower drive shaft support bearing bracket to engine block bolt (Figure 11).

- Drive shaft support bearing bracket to engine block bolt torque: 48.0 N•m (4.9 kg-m, 35 ft-lb)

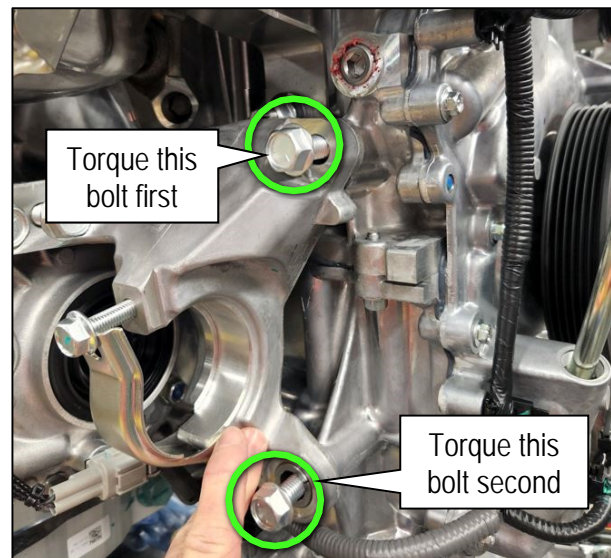

Figure 11

5. Torque the drive shaft support bearing bracket to transfer assembly bolts to specification.
  - Drive shaft support bearing bracket to transfer assembly bolt torque: 48.0 N•m (4.9 kg-m, 35 ft-lb)

## PARTS INFORMATION

DESCRIPTION	MODEL	PART NUMBER	QUANTITY
NUT-HEX (Axle Nut)	QX50, QX55	40262-4GA0C	1
	QX60, QX60 Hybrid	40262-2Y00A	1
SEAL-OIL, DRIVE PINION (Axle Seal)	QX50, QX55, QX60, QX60 Hybrid	33114-4BA0A	1
PIN-COTTER (Cotter Pin)	QX60, QX60 Hybrid	40073-0L700	1
SEAL-OIL (Dust Cover Seal)	QX50, QX55, QX60, QX60 Hybrid	33142-4BA0B	1
GASKET-FILLER PLUG (Gasket)	QX50, QX55, QX60, QX60 Hybrid	11026-1CA0A	1
Genuine Nissan Super Hypoid GL-5 80W-90 (Transfer Oil)	QX50, QX55, QX60, QX60 Hybrid	999MP-1XGPP0P (1)	As needed

(1) Order this item through the Infiniti Maintenance Advantage program: Phone: 877-INF-IMA1 (877-463-4621). Website order via link on dealer portal [www.NNAnet.com](http://www.NNAnet.com) and click on the "Maintenance Advantage" link.

## CLAIMS INFORMATION

Reference the current Infiniti Warranty Flat Rate Manual and use the indicated Flat Rate Time (FRT) for the repair performed.

## AMENDMENT HISTORY

PUBLISHED DATE	REFERENCE	DESCRIPTION
October 25, 2021	ITB21-023	Original bulletin published
June 17, 2022	ITB21-023A	Changes throughout
December 13, 2023	ITB21-023B	<b>APPLIED VEHICLES</b> and Tech•Mate contact information revised