



TECHNICAL SERVICE BULLETIN

Classification:

FA21-009B

Reference:

NTB21-094B

Date:

December 13, 2023

TRANSFER ASSEMBLY SEAL REPLACEMENT FOR AWD FRONT DRIVE SHAFT REMOVAL

This bulletin has been amended. See **AMENDMENT HISTORY** on the last page.
Please discard previous versions of this bulletin.

APPLIED VEHICLES:

- 2019-2024 Altima (L34)
- 2015-2024 Murano (Z52)
- 2016 Murano Hybrid (Z52H)
- 2013-2020 Pathfinder (R52)
- 2014 Pathfinder Hybrid (R52H)
- 2014-2020 Rogue (T32)
- 2021-2023 Rogue (T33)
- 2017-2019 Rogue Hybrid (T32H)
- 2017-2022 Rogue Sport (J11)

APPLIED DRIVELINES: AWD only

HINT: This bulletin does not apply to S35 series Rogue/Rogue Select.

SERVICE INFORMATION

When removing the front passenger (RH) side drive shaft on an **APPLIED VEHICLE** for any reason, transfer assembly drive shaft oil seal and dust cover seal replacement is required.

- Refer to the **SERVICE PROCEDURE** in this bulletin for transfer assembly drive shaft oil seal and dust cover seal replacement.
- Refer to the ESM and NTB17-003 for additional **SERVICE INFORMATION** regarding front passenger (RH) side drive shaft removal and installation.
- **DO NOT REPLACE** the transfer assembly.
 - This repair does not require transfer assembly removal from the vehicle.
 - This repair does not require transfer cover removal from the transfer assembly.
 - When replacing the drive shaft oil seal and the dust seal on 2019-2024 Altima and 2021-2023 Rogue vehicles, it is recommended to remove the drive shaft support bearing bracket for additional clearance.

Nissan Bulletins are intended for use by qualified technicians, not 'do-it-yourselfers'. Qualified technicians are properly trained individuals who have the equipment, tools, safety instruction, and know-how to do a job properly and safely. **NOTE:** If you believe that a described condition may apply to a particular vehicle, DO NOT assume that it does. See your Nissan dealer to determine if this applies to your vehicle.

REQUIRED SPECIAL TOOL(S)

New or replacement Essential Tools are available from Tech•Mate online: www.techmatetools.com, or by phone: 1-833-397-3493.

When ordering, keep in mind that the tool part number prefix has changed from “J” to “NI”. For example, **J-52469-1** is now **NI-52469-1**.



Figure 1



Figure 2



Figure 3



Figure 4

SERVICE PROCEDURE

NOTICE

- To avoid leak recurrence and damage to the transfer assembly, use care when removing the dust cover seal and the drive shaft oil seal.
- To avoid damage to the transfer assembly and the new seals, use an appropriate seal installer and seal protector during the repair.

1. Using a suitable tool, remove the dust cover seal (not shown).
 - Discard the dust cover seal, it will not be reused.
2. Using a suitable tool, remove the drive shaft oil seal (Figure 5).
 - Discard the drive shaft oil seal, it will not be reused.

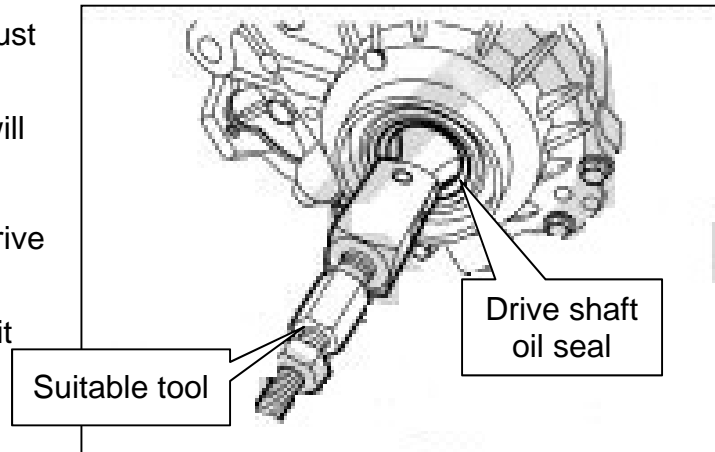

Figure 5

NOTICE

To avoid damage to the new dust cover seal and the new drive shaft oil seal, lubricate the seal lips before installation.

3. Install the new drive shaft oil seal.
 - a. Install the new drive shaft oil seal onto Seal Installer J-52390 (Figure 6).

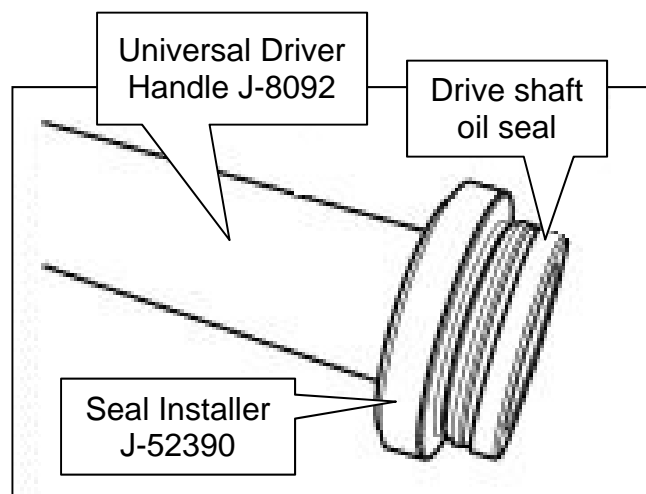

Figure 6

- b. With the help of an assistant, install the new drive shaft oil seal into the transfer assembly to the specified depth of 2.0-2.6 mm (0.079-0.102 in.) using Universal Driver Handle J-8092 and Seal Installer J-52390 (Figure 7).

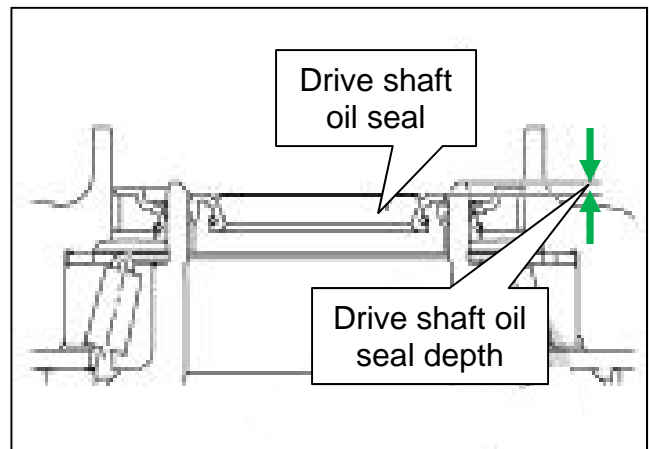

Figure 7

4. Install the new dust cover seal.

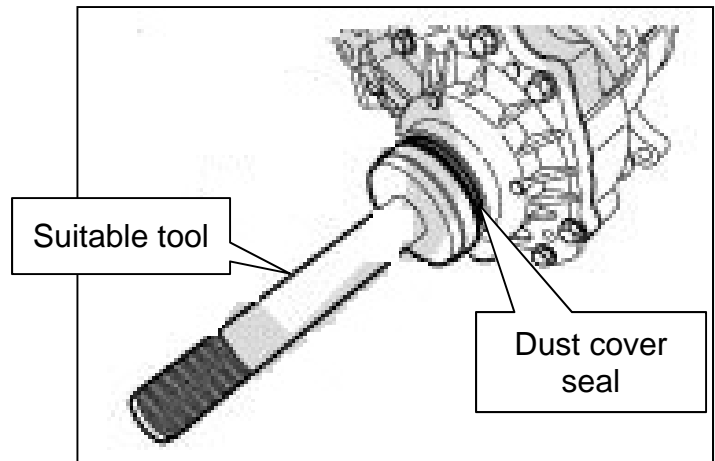

Figure 8

- a. With the help of an assistant, install the new dust cover seal to the specified depth of 0.0-0.6 mm (0.000-0.024 in.) using a suitable tool (Figure 8 and Figure 9).

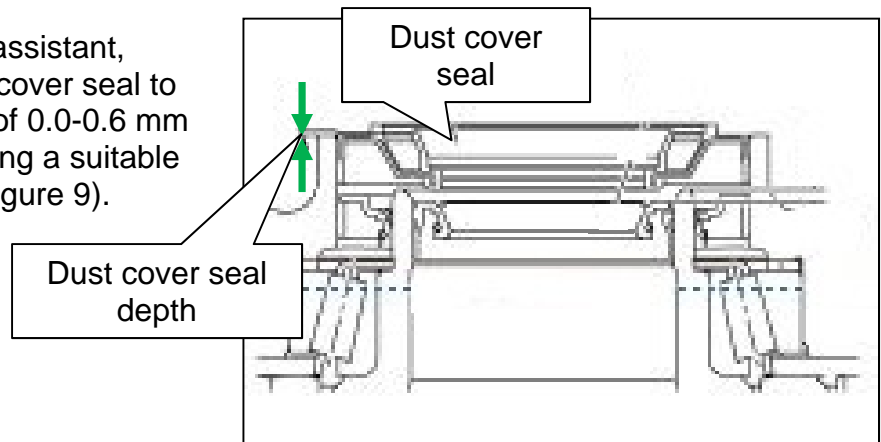

Figure 9

Drive Shaft Support Bracket Installation Recommendations (2019-2024 Altima and 2021-2023 Rogue)

NOTICE

To avoid leak recurrence and damage to the transfer assembly and new seals, follow the sequence below on 2019-2024 Altima and 2021-2023 Rogue vehicles for drive shaft support bearing bracket installation.

1. Place and hold the drive shaft support bearing bracket into position, ensuring it is flat against the engine block and transfer assembly, and loosely install the bolts (Figure 10).

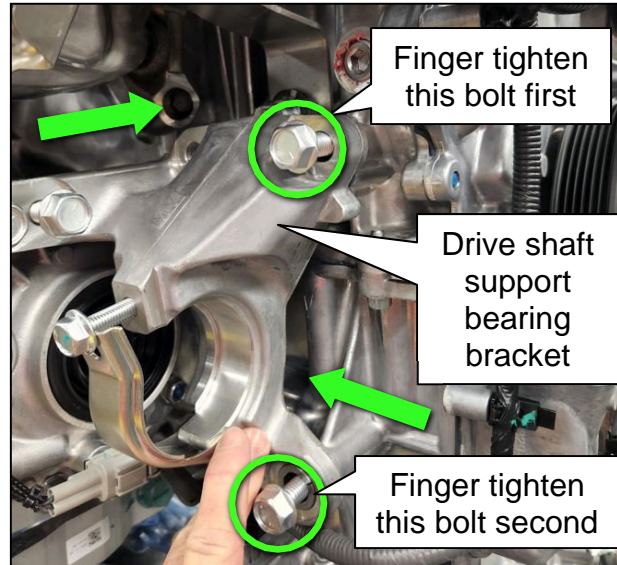

Figure 10

2. While continuing to hold the drive shaft support bearing bracket into position, finger tighten the top drive shaft support bearing bracket to engine block bolt first, and then finger tighten the lower drive shaft support bearing bracket to engine block bolt.
3. Finger tighten the drive shaft support bearing bracket to transfer assembly bolts.

4. While continuing to hold the drive shaft support bearing bracket into position, torque the top drive shaft support bearing bracket to engine block bolt to specification first, and then torque the lower drive shaft support bearing bracket to engine block bolt (Figure 11).

- Drive shaft support bearing bracket to engine block bolt torque: 48.0 N•m (4.9 kg-m, **35 ft-lb**)

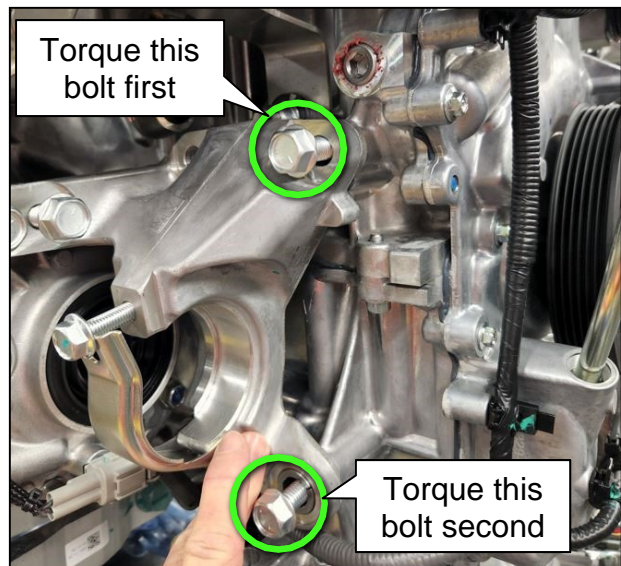

Figure 11

5. Torque the drive shaft support bearing bracket to transfer assembly bolts to specification.
- Drive shaft support bearing bracket to transfer assembly bolt torque: 48.0 N•m (4.9 kg-m, **35 ft-lb**)

PARTS INFORMATION

DESCRIPTION	MODEL	PART NUMBER	QUANTITY
NUT-HEX (Axle Nut)	Altima	40262-4GA0C	1
	Murano, Murano Hybrid, Pathfinder, Pathfinder Hybrid	40262-2Y00A	1
	Rogue (built before 6-1-2018)	40262-2Y00A	1
	Rogue (built 6-1-2018 or later)	40262-JA000	1
	Rogue Hybrid, Rogue Sport	40262-2Y000	1
SEAL-OIL, DRIVE PINION (Axle Seal)	Altima, Murano, Murano Hybrid, Pathfinder, Pathfinder Hybrid Rogue, Rogue Hybrid, Rogue Sport	33114-4BA0A	1
PIN-COTTER (Cotter Pin)	Murano, Murano Hybrid, Pathfinder, Pathfinder Hybrid, Rogue (T32), Rogue Hybrid	40073-0L700	1
	Rogue Sport	00921-5402A	1
SEAL-OIL (Dust Cover Seal)	Altima, Murano, Murano Hybrid, Pathfinder, Pathfinder Hybrid Rogue, Rogue Hybrid, Rogue Sport	33142-4BA0B	1
GASKET- FILLER PLUG (Gasket)	Altima, Murano, Murano Hybrid, Pathfinder, Pathfinder Hybrid Rogue, Rogue Hybrid, Rogue Sport	11026-1CA0A	1
Genuine Nissan Super Hypoid GL-5 80W-90 (Transfer Oil)	Altima, Murano, Murano Hybrid, Pathfinder, Pathfinder Hybrid Rogue, Rogue Hybrid, Rogue Sport	999MP- 1XGPP0P (1)	As needed

(1) Order this item through the Nissan Maintenance Advantage program:
Phone: 877-NIS-NMA1 (877-647-6621). Website order via link on
dealer portal www.NNAnet.com and click on the "Maintenance
Advantage" link.

CLAIMS INFORMATION

Reference the current Nissan Warranty Flat Rate Manual and use the indicated Flat Rate
Time (FRT) for the repair performed.

AMENDMENT HISTORY

PUBLISHED DATE	REFERENCE	DESCRIPTION
October 25, 2021	NTB21-094	Original bulletin published
June 17, 2022	NTB21-094A	Changes throughout
December 13, 2023	NTB21-094B	APPLIED VEHICLES and Tech•Mate contact information revised, and “NOTE” references changed to “HINT”

