

Technical product information

Topic	Headlamp control unit replacement and/or turn signal control unit replacement
Market area	Australia E04 Bentley rest Asia and Australia (6E04),China 723 Volkswagen (Anhui) Automotive CO (6723),China 796 VW Import Comp. Ltd (Vico), Beijing (6796),Germany E02 Bentley rest Europe (6E02),Japan E03 Bentley Japan (6E03),Korea, (South) E08 Bentley South Korea (6E08),United Arab Emirates E06 Bentley Middle East and Africa (6E06),United Kingdom E01 Bentley UK (6E01),United States E05 Bentley USA and rest America (6E05)
Brand	Bentley
Transaction No.	2071933/1
Level	EH
Status	Approval
Release date	

New customer code

Object of complaint	Complaint type	Position
lighting system, signalling -> exterior illumination -> main lights	functionality -> uneven	> not specified <
lighting system, signalling -> exterior illumination -> main lights	functionality -> partially without function	> not specified <
electrical power, electric system, data transfer -> power supply	functionality	

Vehicle data

Bentayga Series and New Flying Spur Series

Sales types

Type	MY	Brand	Designation	Engine code	Gearbox code	Final drive code
4V1*	2021	E		*	*	*
4V1*	2022	E		*	*	*
4V1*	2023	E		*	*	*
4V1*	2024	E		*	*	*
ZG2*	2020	E		*	*	*
ZG2*	2021	E		*	*	*
ZG2*	2022	E		*	*	*
ZG2*	2023	E		*	*	*
ZG2*	2024	E		*	*	*
ZV1*	2023	E		*	*	*

Documents

Document name
master.xml
newflyingspurheadlampcontrolmodule.pdf

Customer statement / workshop findings

Headlamp low beam / high beam malfunction / operational issues (Inner lamp)

Or

Daytime running light malfunction / operational issues (Inner lamp)

Or

Turn signal malfunction / operational issues (Outer lamp)

Technical background

⚠ WARNING
 Vehicles using a High voltage system **MUST** only be worked on by suitably qualified personnel



It is not possible to determine between internal lamp defects and control unit failures therefore this TPI is to advise the replacement of the control unit in the first instance

! NOTICE
IMPORTANT NOTICE: Please ensure that photographs showing the issues found whilst conducting this TPI are attached to a new or existing DISS query as detailed below:

- Photographs showing the actual failure mode
- Photographs after the repair has been successfully completed

Note: Failure to provide the required information could result in warranty claims being cancelled

Hint: In the event the issue was still evident after the control unit was replaced and a new headlamp assembly was fitted, a photograph of the failure mode after control unit replacement is also required



The complete headlamp assembly should only be renewed if the replacement of the control unit was not successful

Or

The control unit has been replaced **TWICE** previously (see note below)

! NOTICE
 The headlamp control unit can only be replaced a **MAXIMUM** of **TWO** times (per headlamp) If there are two yellow paint marks on the control units (Figure 1) or the vehicles repair history shows the control units have been replaced **TWICE**, a new headlamp assembly is required



Figure 1

! NOTICE
 Please ensure that all VIN and symptom related TPI's are conducted before continuing with the instructions within the Measure section in particular TPI 2054599/-

Production change

Not applicable

Measure

CAUTION

Have the instructions within TPI 2054599/- been conducted?

Yes - Carry out the remaining instructions from step 1

No - Conduct TPI 2054599/- **Hint:** In the event the issue is still evident after conducting TPI 2054599/- please continue with the onward instructions

1) Referring to Rep.Gr 94 - Replace the headlamp control unit



Note: In the event the headlamp control unit procedure is not visible within Rep.Gr 94 the operative should refer to the Bentley Hub searching for the following:

- New Flying Spur Headlamp Control Module

The procedure will be published within Rep.Gr 94 when available

Hint: The procedure is also attached to this TPI



Important note for Bentley models with an auxiliary heater (Right hand headlamp control unit)

When replacing the right hand headlamp control unit the operative must also remove the auxiliary heater as detailed in Rep.Gr 82

2) On completion apply a yellow paint mark as shown in Figure 1 and/or Figure 2 (depending if the control unit has been replaced once (Figure 1) or twice (Figure 2))



Figure 1



Figure 2

NOTICE

In the event the issue is not resolved after the headlamp control unit has been replaced and TPI 2054599/- has been conducted, the operative must replace the complete headlamp assembly as detailed within Rep.Gr 94

- Carry out a short road test to confirm the headlamps are fully functional
- On return from road test - using ODIS recheck for any returning DTC's
- Should the DTC's not be evident and the headlamps are fully functional, no further action is required

However

In the event the issue is not resolved the operative must respond via an existing DISS query or raise a new technical DISS query and await a response before conducting any further work

Warranty accounting instructions

NOTICE

IMPORTANT NOTICE: Please ensure that photographs showing the issues found whilst conducting this TPI are attached to a new or existing DISS query as detailed below:

- Photographs showing the actual failure mode
- Photographs after the repair has been successfully completed

Note: Failure to provide the required information could result in warranty claims being cancelled

Hint: In the event the issue was evident after the control unit was replaced and a new headlamp assembly was fitted, a photograph of the failure mode after control unit replacement is also required

Warranty type 110 or 910
 Damage service number 94 18 - Control unit
 Damage service number 94 15 - Headlamp assembly
 Damage code 00 40

Bentayga without Auxiliary heater

Time to remove and refit (x1) front wheel arch liner

Labour operation code 66 16 19 01
 Time 20 TU

Time to remove and refit (x2) front wheel arch liners

Labour operation code 66 16 20 01
 Time 40 TU

NOTICE
Hint: This LOT must only be claimed once in the event the headlamp control unit or headlamp unit was diagnosed as faulty and all checks were conducted as described within TPI 2054599/-

Time to replace the headlamp control unit

Labour operation code 94 01 19 50
 Time 10 TU

Time to replace the headlamp if the control unit has been replaced twice

Labour operation code 94 15 19 00
 Time 260 TU

Time to align both headlamps

Labour operation code 94 15 16 00
 Time 20 Time units

Diagnosis time

Labour operation code 01 50 00 00
 Time As per ODIS log Must not exceed 10 Time units

Road test

Labour operation code 01 21 00 01
 Time 30 TU

Bentayga with Auxiliary heater

Time to remove and refit (x1) front wheel arch liner

Labour operation code 66 16 19 01
 Time 20 TU

Time to remove and refit (x2) front wheel arch liners

Labour operation code 66 16 20 01
 Time 40 TU

NOTICE
Hint: This LOT must only be claimed once in the event the headlamp control unit or headlamp unit was diagnosed as faulty and all checks were conducted as described within TPI 2054599/-

Time to remove and refit the auxiliary heater to gain access to the headlamp control unit

W12 engine

Labour operation code 82 20 19 00

Time 170 TU

V8 Kovomo engine

Labour operation code 82 20 19 20

Time 150 TU

V8 Diesel

Labour operation code 82 20 19 40

Time 170 TU

Time to replace the headlamp control unit

Labour operation code 94 01 19 50

Time 10 TU

Time to replace the headlamp if the control unit has been replaced twice

Labour operation code 94 15 19 00

Time 260 TU

Time to align both headlamps

Labour operation code 94 15 16 00

Time 20 Time units

Diagnosis time

Labour operation code 01 50 00 00

Time As per ODIS log Must not exceed 10 Time units

Road test

Labour operation code 01 21 00 01

Time 30 TU

New Flying Spur

Time to remove and refit (x1) front wheel arch liner

Labour operation code 66 16 19 01

Time 30 TU

Time to remove and refit (x2) front wheel arch liners

Labour operation code 66 16 20 01

Time 40 TU

NOTICE

Hint: This LOT must only be claimed once in the event the headlamp control unit or headlamp unit was diagnosed as faulty and all checks were conducted as described within TPI 2054599/-

Time to replace the headlamp control unit

Labour operation code 94 01 19 50

Time 10 TU

Time to replace the headlamp if the control unit has been replaced twice

Labour operation code 94 15 19 00

Time 290 TU

Time to align both headlamps

Labour operation code 94 15 16 00

Time 20 Time units

Diagnosis time

Labour operation code 01 50 00 00

Time As per ODIS log Must not exceed 10 Time units

Road test

Labour operation code 01 21 00 01

Time 30 TU

Parts information

Headlamp control unit - 992 941 592BA (x1)

CAUTION

Part numbers can change without notice, please refer to the ETKA parts catalogue to ensure the latest specification part is ordered/supplied

General Information

The headlamp control unit is accessible from under the front wheel arch apertures.



Note

The headlamp control unit can only be changed a MAXIMUM of TWO times per headlamp. If there are already two yellow reference marks on the back of the headlamp assembly, then a NEW headlamp assembly complete will be required, available through ETKA.

Right hand side headlamp control module shown, left hand side is symmetrically opposite, unless where stated.



Caution

Ensure that before removal of the headlamp control unit that the area immediately around the headlamp control unit, is clean and free from debris that could enter the headlamp assembly.



WARNING

Ensure that the correct personal protective equipment is worn.

Ensure that the vehicle is fully cooled before commencing work in this area.

Special tools and workshop equipment required

- ◆ Vehicle tester



- ◆ External torx plus socket WT 10670

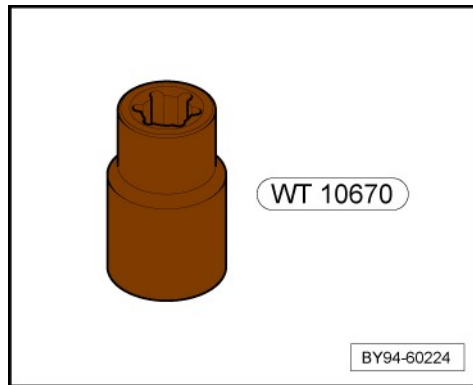

Torque tightening values

Unless otherwise shown, standard torque values apply. ⇒ [/BAS/After Sales Publication/Vehicle electrics/00 - Technical data, Materials](#)

Removal

- Remove the relevant front wheelarch liners. Refer to “Front wheelarch liners - To remove and fit” ⇒ [/BAS/After Sales Publication/Body/66 - Exterior equipment](#)
- Remove the two fixings **-arrows-** that retain the bracket **-1-**.

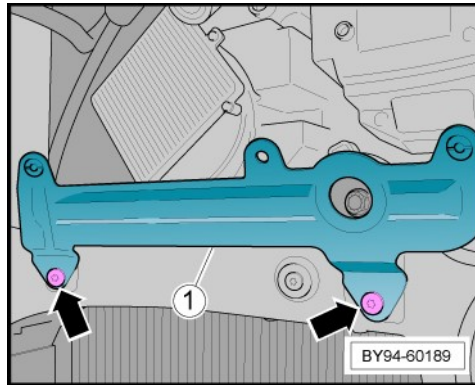

- Remove the two fixings **-arrows-** (4) Nm that retain the bracket **-1-**.

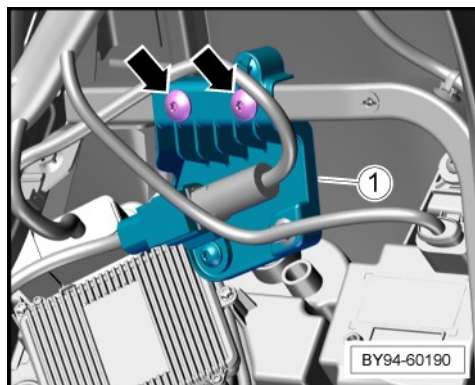

Image for illustration purposes only.

- Disconnect the headlamp assembly harness connector **-1-**, then using the External torx plus socket WT 10670 remove the three fixings **-arrows-** (1.5) Nm, that retain the headlamp control unit **-2-**.

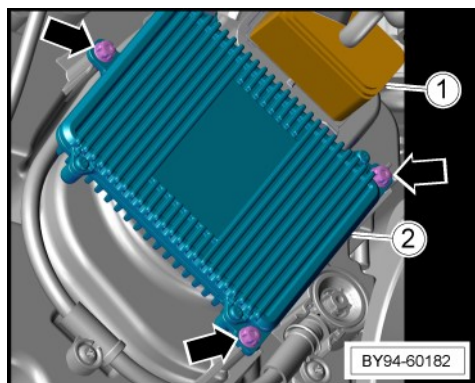
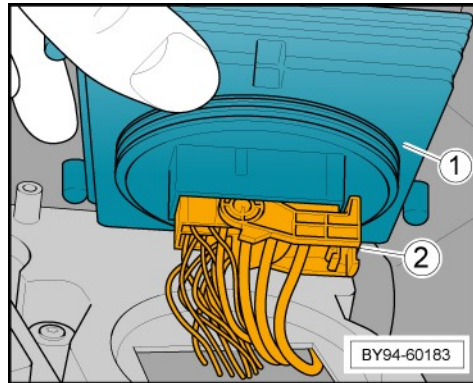

Image for illustration purposes only.

- Carefully extract the headlamp control unit -1- out from the headlamp assembly, only enough to gain access to the harness connector **-2-**.



Caution

Take care NOT to over extend the wires out from the headlamp assembly, as damage to the wires can result.

- Press the catch **-1-** in the direction of **-arrow-**, and at the same time rotate the harness plug retainer **-2-** outwards as shown, enough to allow the harness plug to disconnect from the control module.

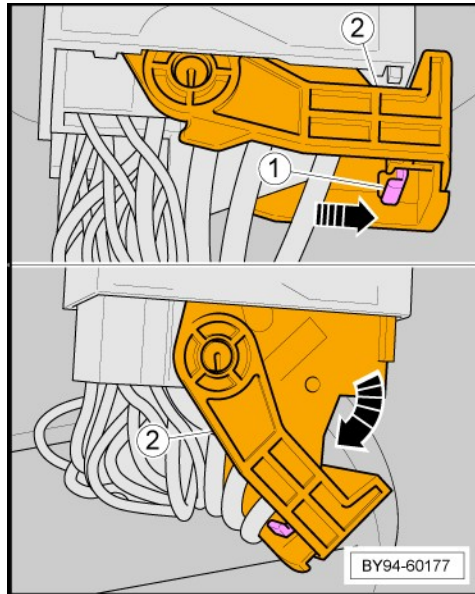

- Remove the control module.

Installation

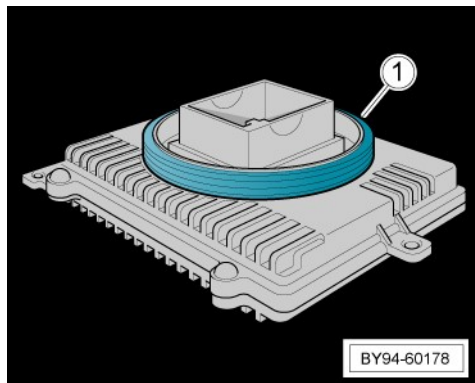

Installation is the reverse of removal procedure, noting the following.

- Pay attention to the seal **-1-**, and ensure that there is NO damage, and that the seal is seated correctly as shown.
- Re-connect the harness connector **-1-**, and fully close the retainer **-2-**.

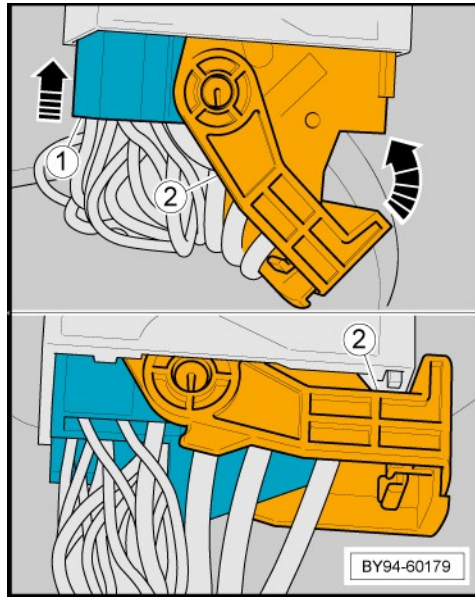

- When correct retention of the harness connector is achieved, an audible click will be heard.
- Re-insert the control module **-1-** into the headlamp assembly apertures **-highlighted-** being careful not to dislodge the control module seal **-2-**.

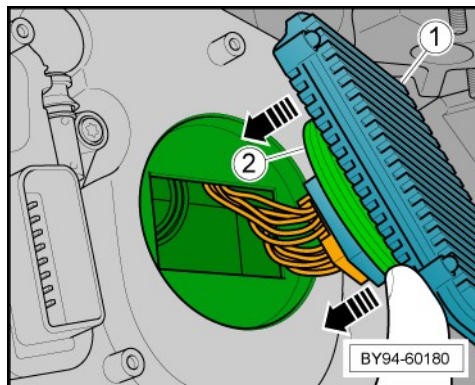

Image for illustration purposes only.

- Press the control module into the headlamp assembly, evenly and square.
- insert the three fixings **-arrows-** and using the External torx plus socket WT 10670 torque tighten to (1.5) Nm.

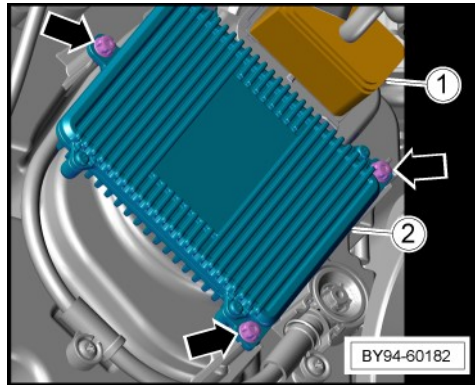

Image for illustration purposes only.

- Reconnect the headlamp assembly harness connector **-1-**

Disregard position **-2-**.



Note

Once the headlamp control unit has been replaced, suitably mark the back of the headlamp assembly with a single neat yellow line.

- Further assembly required.
- Upon completion, connect the Vehicle tester and start ODIS Service:
 - ◆ Select •Guided functions” and allow to sweep.
 - ◆ Select •D6 or D7” in the block diagram.
 - ◆ Select •Replace”.
 - ◆ Follow the on screen prompts.
- Calibrate the matrix headlamps (where fitted). Refer to “Matrix headlamps – To calibrate” ⇒ [/BAS/After Sales Publication/Running gear/44 - Wheels, Tyres, Wheel](#)

alignment

- Ensure that the operation of the headlamp is checked and is operating correctly before driving the vehicle on the road.