



Service Bulletin

File in Section: -

Bulletin No.: 16-NA-023

Date: February, 2016

INFORMATION

Subject: 2016 Buick Cascada New Model Features

Attention: United States Only

Brand:	Model:	Model Year:		VIN:		Engine:	Transmission:
		From:	To:	From:	To:		
Buick	Cascada	2016	2016	All	All	4 Cylinder L4 1.6L Turbocharged — RPO LWC	Hydra-Matic™ 6T45 6-Speed Automatic FWD — RPO MH7

Overview



4339806



4339859

Bulletin Purpose

This is a special bulletin to introduce the 2016 Buick Cascada. The purpose of this bulletin is to help the Service Department Personnel become familiar with some of the vehicle's new features and to describe some of the action they will need to take to service this vehicle.

About the Car

The 2016 Buick Cascada will be the first Buick convertible offered in North America in 25 years and will be offered in two trim levels, the Cascada 1SV and the Cascada Premium 1SP. The Cascada's 2+2 configuration offers comfortable room for four adults and Buick's sophisticated HiPer Strut front suspension and the responsive Watts Z-link rear suspension, rooted in a rigid body structure provides an impressive,

comfortable and refined driving experience. The Cascada rides on a 106.1-inch (2,695 mm) wheelbase which enhances ride smoothness while enabling greater rear-seat legroom.

The vehicle is powered by a 1.6L turbocharged engine that is exclusive to the Cascada in the Buick lineup, with an estimated 200 horsepower (149 kW) @ 5,500 rpm and 207 lb-ft (280 Nm) of torque @ 1,800 to 4,500 rpm **with** an overboost feature that briefly pushes torque to an estimated 221 lb-ft (300 Nm) @ 2,200 to 4,000 rpm. Direct injection and variable valve timing complement the turbocharged engine's performance with efficiency and power is transmitted to the ground via a Hydra-Matic™ 6T45 6-speed FWD automatic transmission.

The Cascada's strategically reinforced body structure is the foundation for the car's strength and as a result of the structure's rigidity, engineers were able to tune the suspension and steering systems with a high degree of precision because there wasn't a need to compensate for chassis flex. Important elements include:

- A-pillars featuring press-hardened steel in the inner structures and reinforced with high-strength, hot-rolled and cold-bent tubes within the pillars.
- Reinforced rocker panels with increased cross section.
- Underbody reinforcements including X-braces, V-braces and additional brackets.
- A reinforced **torsion box** bulkhead behind the rear seats incorporates the Rollover Protection System, which includes a reinforced windscreen frame and spring-loaded, pyrotechnically activated, pop-up rollover bars. When deployed, the rollover bars will extend approximately 14-inches (356 mm) to match the height of the windshield.



4355185

An additional advantage of the Rollover Protection System is that it enables a rear seat cargo pass-through from the trunk to the passenger compartment of 22.4-inch by 12.6-inch (569 mm by 320 mm), because the system is less obtrusive than

some other vehicle's hoop-style pop-up protection systems. When the 50/50-split rear seats are folded - the rear seatbacks fold down electronically, longer items such as skis and wakeboards can be stowed inside. The Cascada offers plenty of storage space, including 13.4 cubic feet (380 liters) of cargo room with the convertible top up and 9.8 cubic feet (280 liters) with the top down.



4355215

The stowage compartment lid extends rearward to accommodate the folding softtop. The electro-hydraulic power roof system features multilayer construction, including acoustic and thermal barriers. The traditional convertible fabric roof top with a fleece lining has superior acoustic and thermal insulation qualities and can be lowered in only 17 seconds at speeds of up to 31 mph (50 km/h). Up-down operation of the top is controlled using **only one lever**. The rigid body structure allows the top, its folding mechanism and the Rollover Protection System roll bar apparatus to be stowed below the car's belt line and under a hard tonneau cover for a smooth uninterrupted profile, giving the car a pure open-air aesthetic with enhanced cargo space.

Technology and Safety Highlights

- Buick IntelliLink® with a 7-inch (178 mm) diagonal color touch screen featuring Text Message Alerts and Siri® Eyes Free for Apple® iPhones® with an iOS 6 or newer operating system.
- Available OnStar® 4G LTE with a built-in Wi-Fi hotspot.
- Electronic rear-seat entry system automatically powers the front seats forward by simply pressing the seatback forward. It moves the seats back when the seatback is returned to the upright position.
- Automatic safety belt presenters that use telescopic arms to slide the upper front safety belt assemblies from behind the front seat into closer reach for easier buckling.

- Rollover Protection System.
- Lane Departure Warning, Rear Park Assist, Rear Vision Camera and Rainsense™ automatic windshield wipers. Wipers turn **ON** automatically when sensors detect moisture on the windshield and turn **OFF** when water is no longer present.

Additional Standard Features

Additional standard features include:



4355577

- High-intensity discharge (HID), articulating headlamps and front LED daytime running lamps; and LED tail lamps.
- Navigation radio and seven-speaker premium audio system.
- Rear Vision Camera (RVC).
- Remote start.
- Dual-zone climate control.
- Front and rear 12-volt power outlets.
- Remote Keyless Entry (RKE) transmitter also controls the **fuel door** lock and unlock feature. Press the unlock button on the RKE to unlock both doors, trunk and the fuel door.
- Heat-reflective leather-appointed seating.
- Heated front seats with 8-way power adjustments.
- Heated and leather wrapped 3-spoke steering wheel.
- Electric power steering.
- Rear Park Assist.
- 20-inch aluminum wheels with bi-color finish.

A Cascada Premium model adds the following standard features:

- Forward Collision Alert (FCA).
- Lane Departure Warning (LDW).
- Front and Rear Park Assist.
- Automatic headlamp control with tunnel detection.
- Rainsense™ automatic windshield wipers.
- Front and rear air deflectors.



4355623

- 20-inch wheels with “diamond graphic” bi-color finish.

Engine



4341985

Typical underhood view of the Cascada 1.6L turbocharged engine.

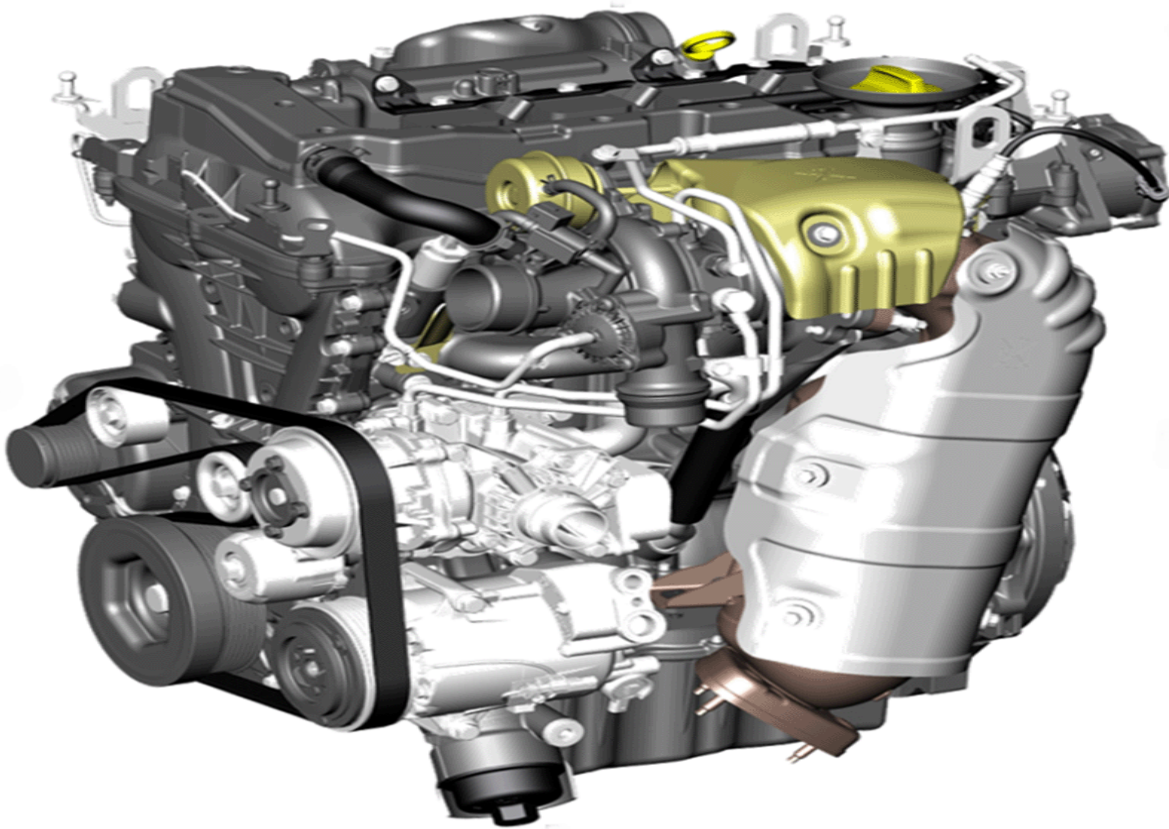

The Ecotec 1.6L turbocharged engine is standard and is part of a new global family of midsize-displacement gasoline engines designed with greater power density to deliver consistent performance and efficiency.

4375012

- **Displacement:** 97.52 ci (1.598L)
- **Bore and Stroke:** 3.11 inch x 3.20 inch (79.0 x 81.5 mm)
- **Cylinder Head:** The cylinder head is a dual overhead camshaft (DOHC) design, made of cast aluminum alloy with 4 valves per cylinder.

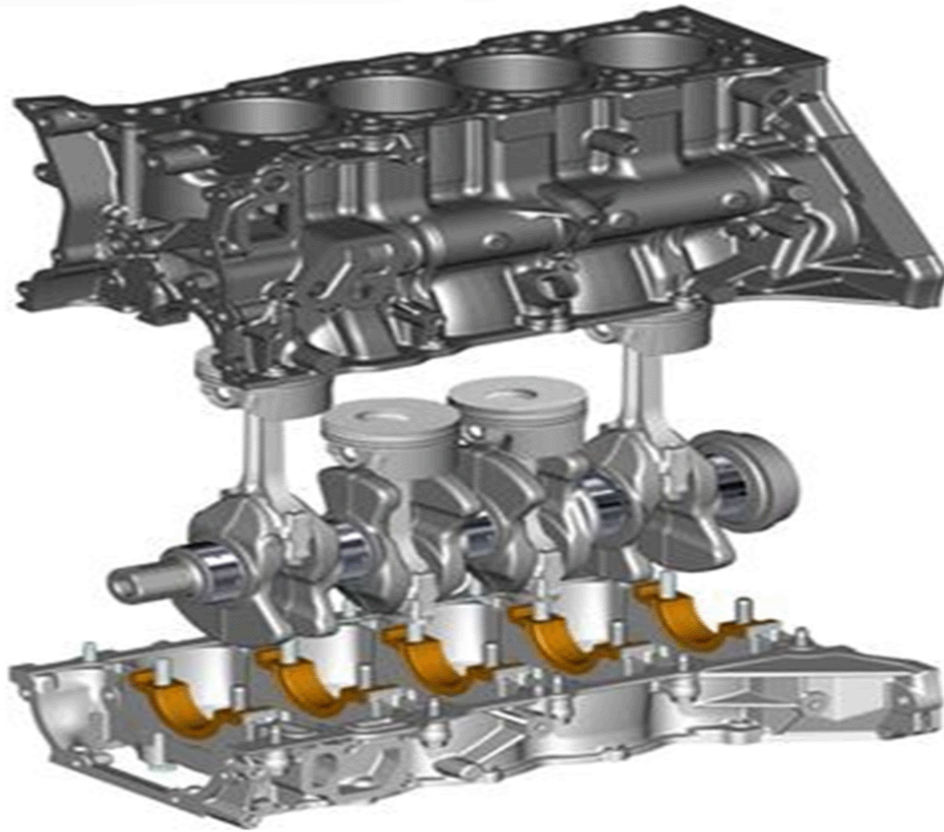

- **Cylinder Block:** The cylinder block is cast iron (3 mm thin wall casting) with an aluminum bedplate and cast iron inserts with 5 main journals.
- **Pistons:** Aluminum pistons with floating pin.
- **Connecting Rods:** Fractured steel with bushing.
- **Crankshaft:** A steel crankshaft is used and is supported in 5 main journals by main bearings with oil clearance for lubricating. The 3rd bearing is the thrust bearing which provides the proper axial end play.



4375026

4368306

- **Crankshaft Harmonic Damper:** The crankshaft harmonic damper is used to control torsional vibration and has an integrated one-way clutch with reduced NVH for the drive belt system.
- **Camshaft:** Two camshafts are used, one for all intake valves and one for all exhaust valves. The camshafts are made of cast iron. The camshaft sprocket wheels are installed in front of the camshafts and are driven by the crankshaft via the camshaft timing chain.

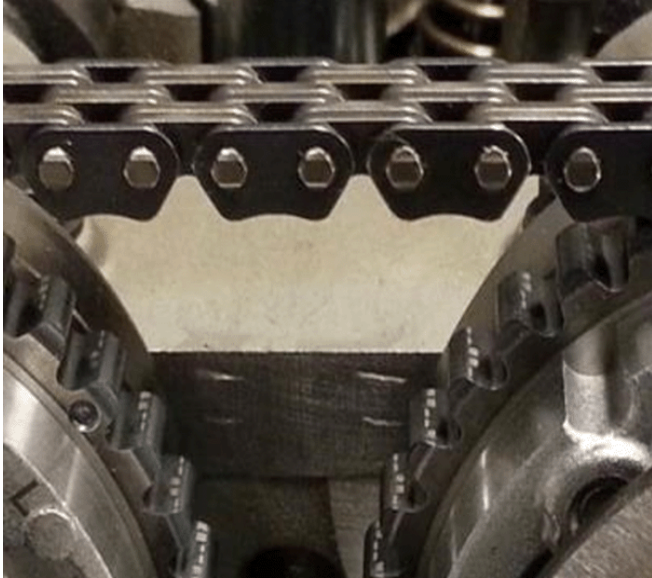

4364743

- **Camshaft Timing Chain:** The inverted teeth design of the camshaft timing chain reduces noise. A tensioner is used to control the amount of tension applied to the chain.
- **Valvetrain:** DOHC, four-valves per cylinder, continuously variable valve timing
- **Valve Lifters:** Hydraulic valve lash adjusters.
- **Intake Manifold:** The intake manifold provides the air flow passages to the cylinder combustion chambers and is made from plastic.
- **Ignition System:** Coil-on-plug.



4364880

- **Fuel Delivery:** High-pressure direct injection with the injectors having a central location over the combustion chambers. The configuration forms a compact package with the capability to support homogeneous and stratified injection.
- **Compression Ratio:** 9.5:1
- **Horsepower:** 200 horsepower (149 kW) @ 5,500 rpm (SAE Certified).
- **Torque:** 207 lb-ft (280 Nm) of torque @ 1,800 to 4,500 rpm (SAE Certified) *with* an overboost feature that briefly pushes torque to an estimated 221 lb-ft (300 Nm) @ 2,200 to 4,000 rpm.
- **Maximum Engine Speed (Fuel Cut-Off):** 6,500 rpm
- **Mechanical Vacuum Pump:** Driven by the exhaust camshaft, it draws air from the vacuum brake booster to provide brake assist.
- **Oil Pan:** A structural aluminum oil pan is used.
- **Recommended Fuel:** Use premium unleaded gasoline meeting ASTM specification D4814 with a posted octane rating of 91 or higher. Regular unleaded gasoline rated at 87 octane or higher can be used, but acceleration and fuel economy will be reduced, and an audible knocking noise may be heard. If this occurs, use a gasoline rated at 91 octane or higher as soon as possible.
- **Emission Controls:** Close-coupled catalytic converter; continuously variable valve timing; 58X ignition system; returnless fuel rail.

dexos® Engine Oil



3512027



3511747

Ask for and use engine oils that meet the dexos® specification. Engine oils that have been approved by GM as meeting the dexos® specification are marked with either of the dexos1® approved logos that are shown. For additional information, visit this General Motors website: <http://www.gmdexos.com>

Viscosity Grade

Use ACDelco dexos1® synthetic blend SAE 5W-30 viscosity grade engine oil. In an area of extreme cold, where the temperature falls below -20°F (-29°C) use SAE 0W-30 engine oil. An oil of this viscosity grade will provide easier cold starting for the engine at extremely low temperatures.

Engine Oil Life System

The vehicle features GM's engine oil life system, which better protects engines by recommending oil changes based on a computer software algorithm using actual engine operating conditions and can save the vehicle owner money by avoiding unnecessary oil changes.

Transmission

Hydra-Matic™ 6T45 6-Speed Automatic FWD Transmission — RPO MH7



4372460

Typical view of the Hydra-Matic™ 6T45 6-speed automatic FWD transmission.

The Hydra-Matic™ 6T45 6-speed front-wheel-drive, electronically controlled, fully automatic overdrive transaxle with an electronically controlled torque converter clutch, comes standard with the 1.6L turbocharged engine. It consists primarily of a 3 element torque converter, a compound planetary gear set, friction and mechanical clutch assemblies and a hydraulic pressurization and control system.

Six-speed automatic transmissions are integral in GM's initiative to offer vehicles with excellent fuel economy and driveability. Designed for FWD and AWD applications, they are used in many of GM's newest and most popular models. The 6T40 (MH8) and 6T45 (MH7, MHC) share many components. The 6T45 is rated for greater torque capacity due to specific component enhancements over the 6T40. Each is part of GM's family of technologically advanced, fuel-saving six-speed automatics. The transmission case material is made from die cast aluminum. The transmission uses DEXRON® VI transmission fluid.

Torque Converter

The 3-element torque converter contains a pump, stator and turbine with an integral isolator and clutch. The torque converter acts as a fluid coupling to smoothly transmit power from the engine to the transmission. It also hydraulically provides additional torque multiplication when required. The clutch pressure plate

when applied, provides a mechanical direct drive coupling of the engine to the transmission. The torque converter features:

- A single-plate lock-up clutch
- Electronic Controlled Capacity Clutch (ECCC) technology
- Elliptical cross-section shape

Transmission Gear Ratios

The transmission has the following gear ratios:

- **First:** 4.58
- **Second:** 2.96
- **Third:** 1.91
- **Fourth:** 1.44
- **Fifth:** 1.00
- **Sixth:** 0.74
- **Reverse:** 2.94
- **Final Drive Ratio:** 3.23

Transmission Fluid Level and Condition Check

When performing fluid checks, always refer to SI for the proper procedure.

- The compact transmission design of the Hydra-Matic™ 6T45 makes proper transmission fluid level even more critical.
- The transmission fluid level **must be** checked when the transmission fluid temperature (TFT) is between 185–203°F (85–95°C).
- The engine **must be** running when the transmission fluid oil level check plug is removed.
- **Do not** add more than 0.5 pint (227 ml) at a time without rechecking the fluid level.

Brakes

This vehicle is equipped with a Continental Teves Mk60/Mk70 brake system. The electronic brake control module (EBCM) and the brake pressure modulator valve assembly are serviced separately. The brake pressure modulator valve assembly uses a 4 circuit configuration to control hydraulic pressure to each wheel independently. The following vehicle performance enhancement systems are provided:

- **Antilock Brake System (ABS):** When wheel slip is detected during a brake application, an ABS event occurs. During ABS braking, hydraulic pressure in the individual wheel circuits is controlled to prevent any wheel from slipping. A separate hydraulic line and specific solenoid valves are provided for each wheel. The ABS can decrease, hold, or increase hydraulic pressure to each wheel. The ABS does not, however, increase hydraulic pressure above the amount which is transmitted by the master cylinder during braking.
- **Traction Control:** When drive wheel slip is noted, the EBCM will enter traction control mode. First, the EBCM requests the engine control module (ECM) to reduce the amount of torque to the drive wheels via a serial data message. The ECM reduces torque to the drive wheels and reports the amount of delivered torque. If the engine torque

reduction does not reduce drive wheel slip, the EBCM will actively apply the brakes on the slipping drive wheel. During traction control braking, hydraulic pressure in each drive wheel circuit is controlled to prevent the drive wheels from slipping. The EBCM commands the pump motor and appropriate solenoid valves ON and OFF to apply brake pressure to the slipping wheel.

- **Stability Control:** Stability control provides added stability during aggressive maneuvers. Yaw rate is the rate of rotation about the vehicle's vertical axis. The stability control is activated when the EBCM determines that the desired yaw rate does not match the actual yaw rate as measured by the yaw rate sensor.
- **Dynamic Rear Proportioning:** The dynamic rear proportioning is a control system that replaces the mechanical proportioning valve. Under certain driving conditions the EBCM will reduce the rear wheel brake pressure by commanding the appropriate solenoid valves ON and OFF.
- **Hydraulic Brake Assist:** The hydraulic brake assist function is designed to support the driver in emergency braking situations. The EBCM receives inputs from the brake pressure sensor. When the EBCM senses an emergency braking situation, the EBCM will actively increase the brake pressure to a specific maximum.

Suspension/Electric Power Steering

HiPer Strut Front Suspension

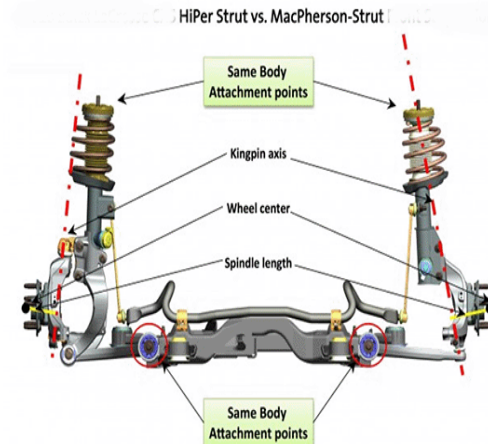

4342138

HiPer Strut is a modified MacPherson strut system and features dual-path top mountings that separate the transfer of spring and damper loads to the body structure. This also allows for a shorter spindle length, thus changing the geometry of the setup, which allows the tire to maintain negative camber while cornering. What that means for the driver is improved tire contact with the pavement under load, reduced torque steer, more-communicative steering, improved impact

isolation on bumps and rough surfaces and less kickback in the steering system when the vehicle runs over imperfections in the road.

Watts Z-Link Rear Suspension

A responsive Watts Z-link design helps center the rear axle during cornering, which helps keep the Cascada's handling responses symmetrical on both left-hand and right-hand turns. The linkage's capability to center the axle during cornering delivers a more-balanced driving experience because the rear suspension better follows the lead of the front suspension. The Z-link design is also lighter and requires less space than a typical fully independent rear suspension. The lower weight enhances efficiency, while the compact design enables the Cascada's generous cargo room.

Electric Power Steering

Steering inputs are executed by a fuel-saving, rack-mounted electric power steering system. It does not have power steering fluid. Regular maintenance is not required. If power steering assist is lost due to a system malfunction, the vehicle can be steered, but it may require increased effort. If the steering wheel is turned until it reaches the end of its travel and is held against that position for an extended period of time, power steering assist may be reduced. Normal use of the power steering assist should return when the system cools down.

Traction Control and StabiliTrak®

The vehicle has a Traction Control System (TCS) and StabiliTrak® which is an electronic stability control system. These systems help limit wheel spin and assist the driver in maintaining control, especially on slippery road conditions.

TCS activates if it senses that any of the drive wheels are spinning or beginning to lose traction. When this happens, TCS applies the brakes to the spinning wheels and reduces engine power to limit wheel spin.

StabiliTrak® activates when the vehicle senses a difference between the intended path and the direction the vehicle is actually traveling. The system selectively applies braking pressure to any one of the vehicle wheel brakes to assist the driver in keeping the vehicle on the intended path.

If cruise control is being used and TCS or StabiliTrak® begins to limit wheel spin, the cruise control will disengage. Cruise control may be turned back **ON** when road conditions allow. Both systems turn **ON** automatically when the vehicle is started and begins to move. The systems may be heard or felt while they are operating or while performing diagnostic checks. This is normal and does not mean there is a problem with the vehicle.

⇒ If the vehicle gets stuck in sand, mud, ice, or snow it may be necessary to turn TCS **OFF**.

Rollover Protection System



4355431

The Rollover Protection System is controlled by the Inflatable Restraint Sensing and Diagnostic Module (SDM). The system activates during a vehicle rollover, head-on collision or side impact. The system deploys with the soft top opened or closed.

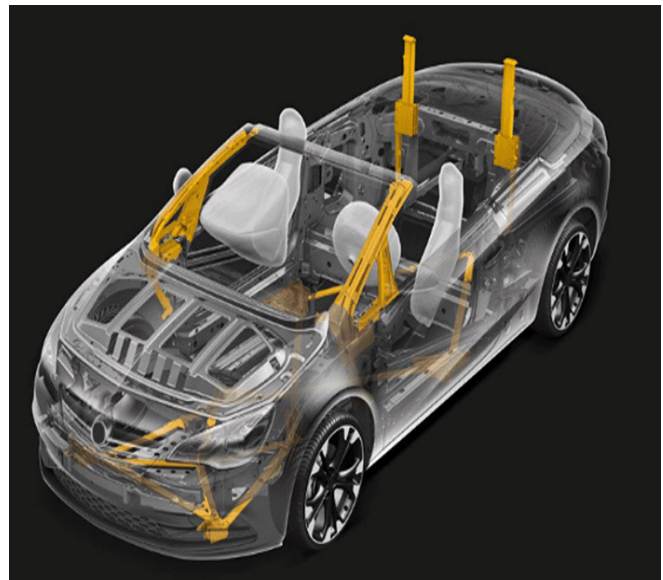

4361340

Typical "ghost" view of the Rollover Protection System including the reinforced A-pillars, V-braces, the rollover bars in an extended state and the reinforced torsion box bulkhead.

The rollover protection system consists of a reinforced windscreen frame and rollover bars under covers behind the rear head restraints. In the event of a vehicle rollover, head-on collision or side impact, the pyrotechnically activated, spring-loaded bars deploy upwards automatically **within milliseconds**. They also deploy together with the front and side airbag systems.

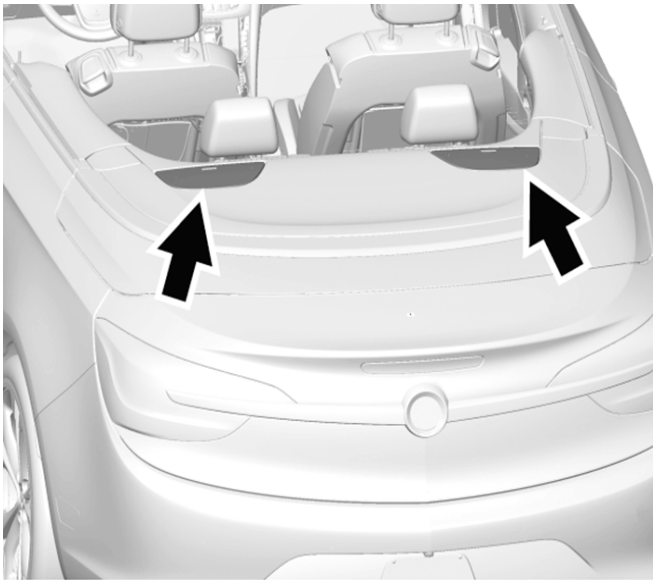

4355458

DO NOT place any objects on the covers of the rollover bars behind the head restraints.

The airbag control indicator illuminates if the rollover bars have been deployed. The soft top **MUST NOT** be operated if the rollover bars have been deployed. A continuous warning will sound and a message appears in the DIC if the switch is actuated.

Service Considerations for the Rollover Bars

- SIR safe handling and storage warnings apply to rollover bars.
- Replacement rollover bars are shipped to the dealer ready to install.
- Rollover bars should be handled and stored the same as an airbag.

Airbag System

All vehicle airbags have the word AIRBAG on the trim or on a label near the deployment opening. The airbags are located in the following positions:

- Driver steering wheel (dual inflators).
- Passenger side instrument panel (dual inflators).
- Knee airbag for the driver.
- Knee airbag for the front outboard passenger.
- Seat-mounted side impact airbag for the driver.
- Seat-mounted side impact airbag for the front outboard passenger.

Power Windows

Power Window Door Switches

The power window switches on the driver door control all four windows. Each passenger door has a switch that controls only that window. Press the switch to the first detent to lower the window. Pull the switch up to

the first detent to raise it. The switches work when the ignition is in ON/RUN or ACC/ ACCESSORY, or in Retained Accessory Power (RAP).

Express Window Operation

Windows with an express-down or up feature allow the windows to be lowered or raised without holding the switch. All door windows have the express-down feature. Front door windows may also have the express-up feature. Pull a window switch up or push it down all the way, release it, and the window goes up or down automatically. Stop the window by pushing or pulling the switch.

Express Window Anti-Pinch Feature

If any object is in the path of the window when the express-up is active, the window will stop at the obstruction and auto-reverse to a preset factory position. Weather conditions such as severe icing may also cause the window to auto-reverse. The window will return to normal operation after the obstruction or condition is removed.

Express Window Anti-Pinch Override

To override the anti-pinch feature, hold the window switch all the way up to the second position. The window will raise for as long as the switch is held. Once the switch is released, the express mode is reactivated. In this mode, the window can close on an object in its path. Use care when using the override mode.

Central Power Window Switch



4364707

The central power window switch will express-open all windows when pressed. Pull the switch to express-close.

Power Door Locks — Central Locking Switch



4363458

The central locking switch locks and unlocks both doors, the trunk, and the fuel door.

- Press the unlock button (1) to unlock.
- Press the lock button (2) to lock.

Seat Belt Presenters



4363543

Unique to the Cascada convertible are the seat belt presenters. They function as follows:

- Operated by the Folding Top Control Module.
- Mounted at shoulder level behind the doors.

- Fully automatic, triggered when the doors are closed and the ignition is **ON**.
- If resistance to movement is detected, presenters will reverse then extend again.

Driver Assistance Systems



4355907

- **Rear Vision Camera (RVC):** When the vehicle is shifted into **R** (reverse), the RVC shows what is behind the vehicle on the radio display and provides onscreen track paths to help guide the driver. Displayed images may be farther or closer than they appear. The area displayed is limited and objects that are close to either corner of the bumper or under the bumper do not display.



4358754

- **Forward Collision Alert:** If equipped, FCA may help avoid or reduce the harm caused by front-end crashes. FCA provides a green indicator on the DIC, when a vehicle is detected ahead. When approaching a vehicle ahead too quickly, FCA

provides a visual alert and rapidly beeps when approaching a vehicle directly ahead too quickly. When this Forward Collision Alert occurs, the brake system may prepare for driver braking to occur more rapidly which can cause a brief, mild deceleration. The Cascada **does not** illuminate an amber indicator when following too closely. The forward-looking FCA camera sensor is on the windshield ahead of the rearview mirror. FCA detects vehicles within a distance of approximately 197 ft (60 m) and operates at speeds above 25 mph (40 km/h).

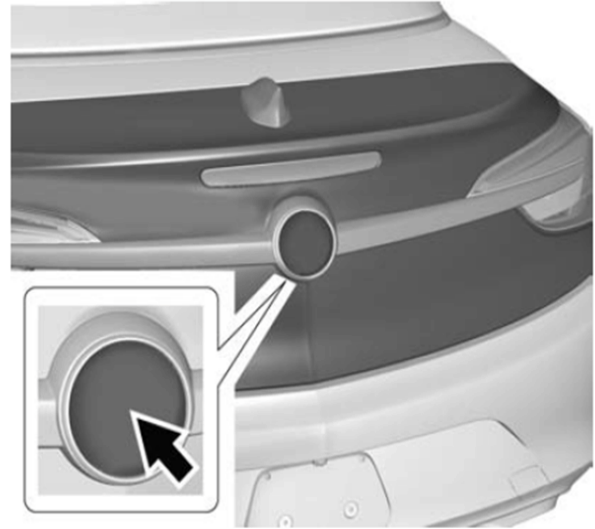

4360761

- Press the lower half of the emblem on the trunk lid.
- Press and hold the trunk release button on the Remote Keyless Entry (RKE) transmitter.

Buick IntelliLink™

4360164

- **Lane Departure Warning (LDW):** If equipped, LDW may help avoid crashes due to unintentional lane departures. It may provide an alert if the vehicle is crossing a lane without using a turn signal in that direction. LDW uses a camera sensor to detect the lane markings at speeds of 35 mph (56 km/h) or greater. When LDW is **ON**, the indicator is green if LDW is available to warn of a lane departure. If the vehicle crosses a detected lane marking without using the turn signal in that direction, the indicator changes to amber and flashes.
- **Rear Park Assist (RPA):** With RPA, as the vehicle backs up at speeds of less than 5 mph (8 km/h), the sensors on the rear bumper detect objects up to 8 ft (2.5 m) behind the vehicle that are within a zone 10 in (25 cm) high off the ground and below bumper level.
- **Front Park Assist:** If equipped with Front Parking Assist (FPA), it also detects objects 4 ft (1.2 m) in front of the vehicle.

Trunk Release

To open the trunk, the vehicle must be **OFF** or the shift lever must be in **P** (Park). To open the trunk, perform one of the following:

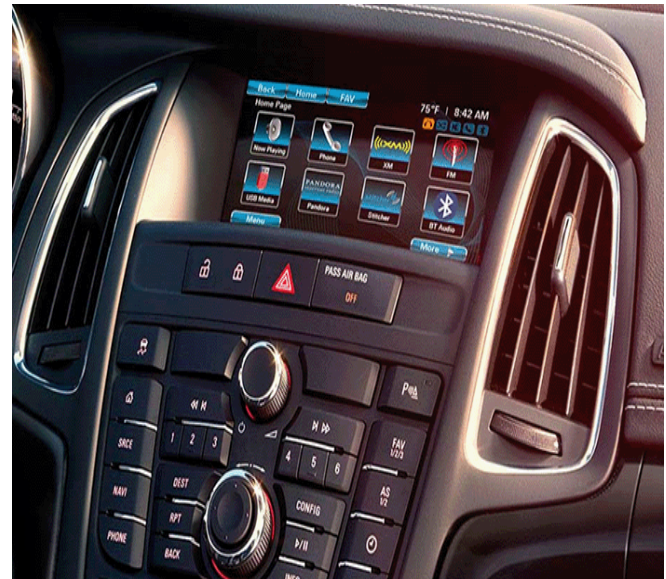

4363844

The latest in voice-recognition and touch-screen technology is seamlessly integrated into the Buick IntelliLink™ infotainment system, so all you have to do to instantly hear your favorite tunes or entertainment is ask for them.

IntelliLink™ now keeps you connected to your most important contacts by providing alerts of incoming text messages. You can configure the system to have incoming text messages read out aloud. In addition, with select smartphones, you can also respond to the text messages with your pre-programmed responses.

The enhanced voice-recognition technology in the 2016 Cascada enables you to better control everything from the music you select to the hands-free calls you place and receive. Drivers with compatible iPhones® can now access Siri®, Apple's voice-activated digital assistant, hands-free. Siri® Eyes Free voice recognition software allows hands-free interaction when you need it the most. Simply pair your iPhone® with the Bluetooth®-enabled Buick IntelliLink™ system, and then use the steering-wheel-mounted voice command button to activate Siri® Eyes Free. You can make calls, compose text or email messages to stored contacts, and access other iPhone® functions, all without taking your hands off the wheel or your eyes off the road.

Note: Full Functionality requires Bluetooth and smartphone. Some devices require USB connectivity. Data plan rates apply.

OnStar® with 4G LTE and Wi-Fi

Stay connected to the internet and your favorite apps anywhere you go with OnStar® 4G LTE built-in-Wi-Fi-hotspot. It's always available and ready to connect to your devices, giving you an integrated and customizable in-vehicle experience.

To retrieve the SSID and password for the hotspot, press the OnStar® Voice Command button on the overhead console or rearview mirror, wait for the prompt, and then say "Wi-Fi settings." The information will be displayed on the screen.

The powerful OnStar® connection also enables improved access to existing OnStar® safety and security services, including the ability to transmit voice and data simultaneously. That means OnStar® advisors can run a diagnostic check without ever leaving the call, making customer interactions quicker and more seamless. It's the most comprehensive in-vehicle safety and connectivity system available.

For assistance, press the blue OnStar® button or call 1-888-4-ONSTAR (1-888-466-7827).

Lifting and Jacking the Vehicle

Note: The use of a LOW PROFILE LIFT ARMS SYSTEM may be required to avoid unwanted contact with the vehicle's body and structure depending on lifting equipment used. Refer to the manufacture's recommendation for their applications of low profile lift arms system for their lifting equipment.

Vehicle Lifting - Frame Contact Lift

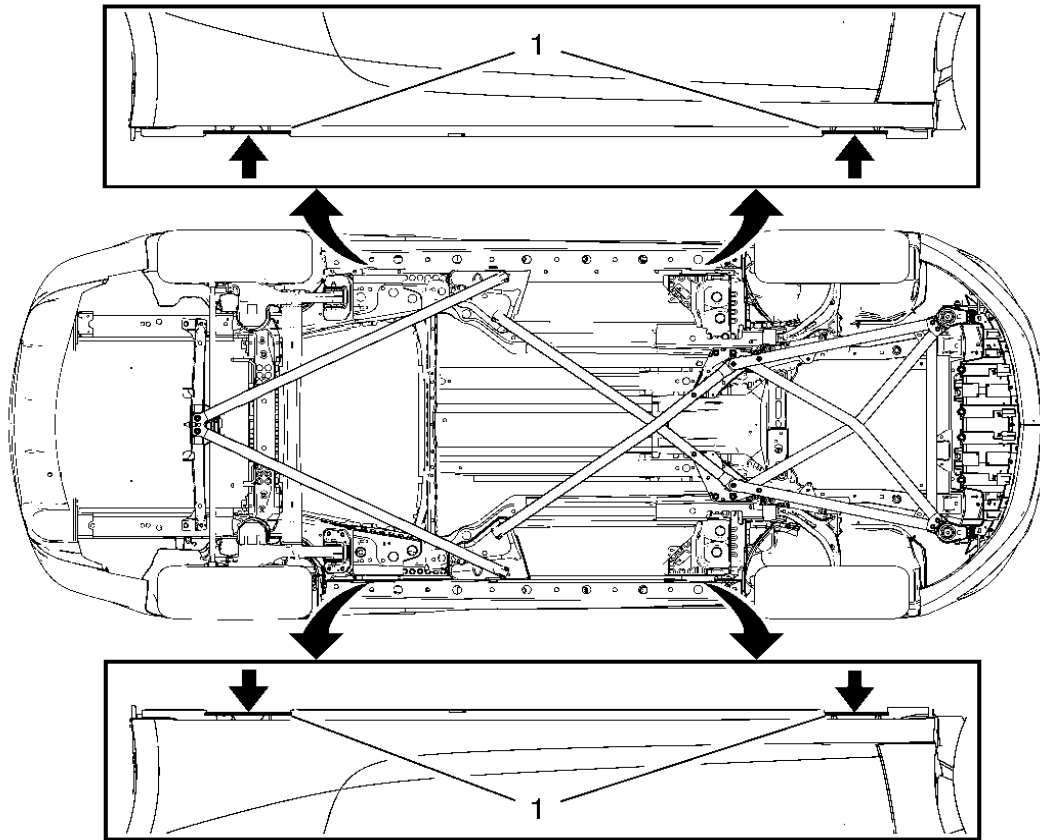

4360675

- **Front Lift Pads:** When lifting the vehicle with a frame-contact lift, place the front lift pads on the rocker outer panel weld flange, as shown.
- **Rear Lift Pads:** When lifting the vehicle with a frame-contact lift, place the rear lift pads on the rocker outer panel weld flange, as shown.

When using a service jack under the front or rear of the vehicle, use the same location as shown for the front and rear lift pads.

Towing the Vehicle — Recreational Vehicle Towing

Towing the Vehicle

Have the vehicle towed on a flatbed car carrier. A wheel lift tow truck could damage the vehicle.

Recreational Vehicle Towing

Recreational vehicle towing means towing the vehicle behind another vehicle, such as behind a motor home. The Cascada was not designed to be towed with all four wheels on the ground, so if the vehicle will be towed a **dolly must be used** under the front wheels.

Dolly Towing

Dolly towing is towing the vehicle with two wheels on the ground and two wheels up on a device known as a dolly. Tow the vehicle with the two rear wheels on the ground and the front wheels on a dolly.

To tow the vehicle with two wheels on the ground and a dolly perform the following:

1. Put the front wheels on a dolly.
2. Put the shift lever in **P** (Park).
3. Secure the vehicle to the dolly.

Training Courses

The majority of the systems found on this vehicle are taught in GM's core curriculum from a conceptual theory and operation perspective. The North American technical training core curriculum structure is system based.

To access **all** of the available training courses visit the following website: **Go to > www.centerlearning.com**

Training Course Name or System — Course Number and Description

Course Name or System	Course Number and Description
New Model Feature 2016 Buick Cascada New Model Feature	#10316.08W — 2016 Buick Cascada New Model Feature (Includes: Convertible Top, Roll Bar System/Apparatus and Automatic Headlamp Control with Tunnel Detection)
Engine 1.6L Turbocharged — RPO LWC	#16440.20D — Engines: New and Updates for RPO LF4, LGX, LGW, L3A, LV7, LE2, LWN and LWC
Transmission Hydra-Matic™ 6T45 6-Speed Automatic Transaxle — RPO MH7	#17440.12D — Transmissions: New and Updates for 6T40/45
Safety Systems Forward Collision Alert / Lane Departure Warning and Rear Vision Camera	#22048.42W2 — GM Safety Systems 2

Special Tools

Special Information — Buick Cascada Convertible Top Service Loan Tools (BO-51074-NA & BO-51074-30)

For Convertible Top Alignment-to-Body service on the 2016 Buick Cascada, BO-51074-NA Convertible Top Alignment Tool is required.

Notice: This tool is only required if the anchor plates have been moved, causing the convertible top to be misaligned to the body. The tool is not required for convertible top removal and replacement.

- Due to the size and cost of BO-51074-NA, Buick Dealers **WILL NOT** automatically receive this special tool kit as part of the Essential Tool Program.

- BO-51074-NA is only available for loan via 1-800-GM-TOOLS and ships from Owatonna, MN via a common freight carrier. There is an estimated \$1,300.00 charge applied to cover transportation costs due to the 450 lbs. of shipping weight. Please allow 3-5 business days for delivery. Return the tool no more than 10 business days after receipt. Damaged or non-returned tool kits may incur a charge of \$8,800.00 USD debited to the dealer's Parts Account.
- Additionally, for Stowage Compartment Hinge Adjustment BO-51074-30 is required and only available for loan via 1-800-GM-TOOLS. There is an estimated \$100 charge applied to cover transportation costs.

The following new tools were released for the 2016 Cascada:

Special Tools — Tool Number and Description

Tool Number	Description
EN-51147	Crankshaft Holding Tool
EN-51148	Camshaft Holding Tool
EN-51151	Seal Ring Installer Crankshaft
EN-51152	Seal Ring Installer Crankshaft
The Following Convertible Top Service Tools are Available for Loan	
BO-51074-NA	Convertible Top Alignment Tool
BO-51074-30	Convertible Top Adjustment Tool

Version Information

Version	1
Modified	—

Trademark Footnotes

Android™ is a Trademark of Google Inc.

Android Auto™ is a Trademark of Google Inc.

Apple® is a Registered Trademark of Apple Inc.

Apple CarPlay™ is a Trademark of Apple Inc.

Bose® is a Registered Trademark of the Bose Corporation

The Bluetooth® Word Mark and Logos are Registered Trademarks Owned by Bluetooth SIG, Inc.

Buick IntelliLink® is a Registered Trademark of General Motors Corporation LLC

dexos® is a Registered Trademark of General Motors LLC

dexos1® Icons are Registered Logos of General Motors LLC

DEXRON® is a Registered Trademark of General Motors LLC

Google® is a Registered Trademark of Google Inc.

Hydra-Matic™ is a Trademark of General Motors LLC

iPhone® is a Registered Trademark of Apple Inc.

Intellibeam® is a Registered Trademark of General Motors LLC

OnStar® is a Registered Trademark of OnStar LLC

Rainsense™ is a Trademark of General Motors LLC

Siri® Eyes Free Voice Recognition Software is a Registered Trademark of Apple Inc.

Siri® is a Registered Trademark of Apple Inc.

StabiliTrak® is a Registered Trademark of General Motors LLC

