

FUEL VAPOR SMELL IN PASSENGER COMPARTMENT – 3.0L and 4.4L

Range Rover

- 22-23MY Range Rover

Customer Voice:

- Fuel smell in cabin

Technical Description:

- During high ambient temperatures, the fuel vapors will be more apparent during an emissions purge cycle.

Status:

- Once parts are available, a TSB will be released detailing the components and repair procedure.
- This will be initially for the US market only based on ambient temperatures

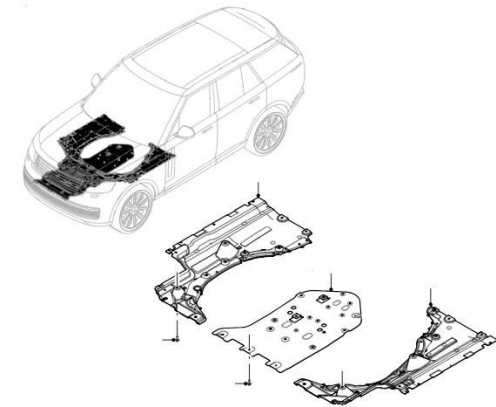

TSB - JLRT02112NAS