



TECHNICAL SERVICE BULLETIN

Lack Of Audio And/Or Water Leak In Rear Of Vehicle And/Or Spare Tire Area

24-2044

21 February
2024

This bulletin supersedes 23-2181. Reason for update: add 2024 vehicle model year.

Model:

Ford 2020-2024 Explorer
Lincoln 2020-2024 Aviator

Issue: Some 2020-2024 Explorer/Aviator vehicles may exhibit a lack of audio and/or a water leak in the rear liftgate area and/or water in the spare tire area. The customer may indicate that this concern is more noticeable after a car wash or rainfall. To correct the condition, follow the Service Procedure to identify the leak path.

Action: Follow the Service Procedure steps to identify the leak path on vehicles that meet all of the following criteria:

- 2020-2024 Explorer/Aviator
- Lack of audio after a car wash or rainfall
- Water in the rear liftgate area and/or water in the spare tire area

Parts

Service Part Number	Claim Quantity	Package Order Quantity	Number in Package	Description
14B350	1	If Needed	1	Aviator Power Liftgate Strut - Refer To The Parts Catalog For The VIN Specific Application
14B351	1	If Needed	1	Power Liftgate Strut - Refer To The Parts Catalog For The VIN Specific Application
18K810	1	If Needed	1	Audio Control Module - Refer To The Parts Catalog For The VIN Specific Application
W710014-S300	2	If Needed	4	Rubber Plug

Quantity refers to the amount of the service part number required to repair the vehicle.

Unit of Issue refers to the number of individual pieces included in a service part number package.

Piece Quantity refers to the total number of individual pieces required to repair the vehicle.

As Needed indicates the amount of the part may vary and/or is not a whole number. Parts can be billed out as non-whole numbers, including less than 1.

If Needed indicates the part is not mandatory.

Warranty Status: Eligible under provisions of New Vehicle Limited Warranty (NVLW)/Service Part Warranty (SPW)/Special Service Part (SSP)/Extended Service Plan (ESP) coverage. Limits/policies/prior approvals are not altered by a TSB. NVLW/SPW/SSP/ESP coverage limits are determined by the identified causal part and verified using the OASIS part coverage tool.

Labor Times

Description	Operation No.	Time
2020-2024 Explorer/Aviator: Repair The Audio System And Any Water Leaks Following The Service Procedure (Do Not Use With Any Other Labor Operations)	MT242044	Actual Time

Repair/Claim Coding

Causal Part:	5827840
Condition Code:	12

Service Procedure

1. Is this an Explorer or Aviator?
 - (1). Explorer - proceed to the Explorer Vehicle Inspection procedure.
 - (2). Aviator - proceed to the Aviator Vehicle Inspection procedure.

Explorer Vehicle Inspection

1. Open the rear liftgate.
2. Inspect and make sure the following components are correctly seated by pushing:
 - (1). Power liftgate grommet (if equipped). If not properly seated, replace the affected power liftgate strut. (Figure 1 Callout 1, Figure 2)
 - (2). Margin seal and margin seal pushpins. (Figure 1 Callout 2, Figure 3 Callout 2)
 - (3). Electrical wiring grommet. (Figure 1 Callout 3, Figure 3 Callout 3)
 - (4). Rear washer hose. (Figure 1 Callout 4, Figure 3 Callout 4)

Figure 1

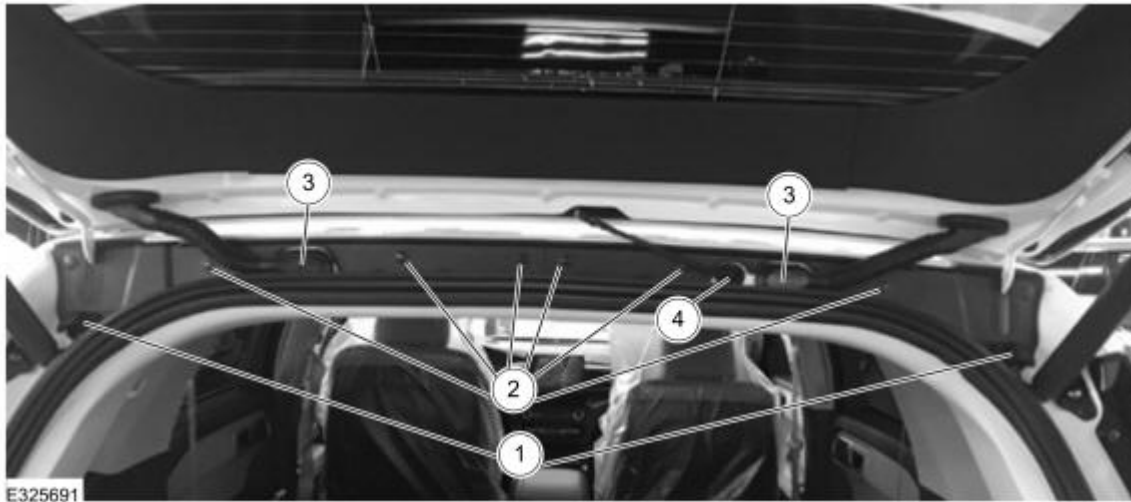

Item	Description
1	Power liftgate grommet (if equipped)
2	Margin seal and margin seal pushpins
3	Electrical wiring grommet
4	Rear washer hose

Figure 2



E325692

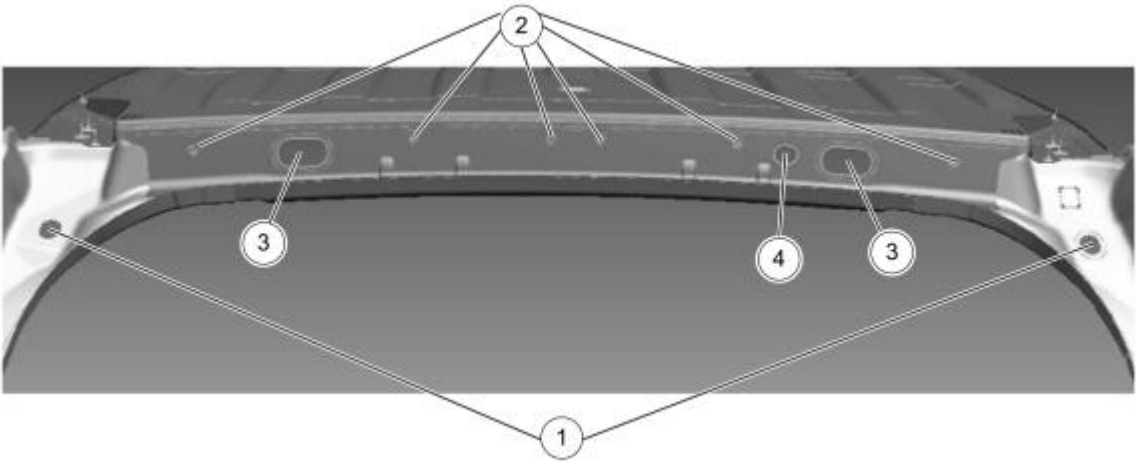

E325693

Item	Description
1	Power liftgate grommet
2	Margin seal and margin seal pushpins

3	Electrical wiring grommet
4	Rear washer hose

3. If a water leak is present on the right side of the vehicle, replace the audio control module (ACM).
 - (1). Reinstall the rain shield (if equipped) on the new ACM. The rain shield, if present, is attached to the ACM chassis using a pushpin which can be reused.
4. Raise the vehicle on a hoist.
5. Inspect the right side rear corner area under the rear bumper cover for the following loose, disconnected, or missing items:
 - (1). Visually inspect for delete tape completely covering the body hole. (Figures 4-6 Callout 1) If the tape is damaged or leaking, replace with a rubber plug.
 - (2). Press down on the blind spot information system (BLIS) module to make sure it is fully seated into the body. (Figures 4-6 Callout 2)
 - (3). Visually inspect the BLIS module wire harness grommet is seated. (Figures 4-6 Callout 3)

Figure 4



Figure 5



Figure 6

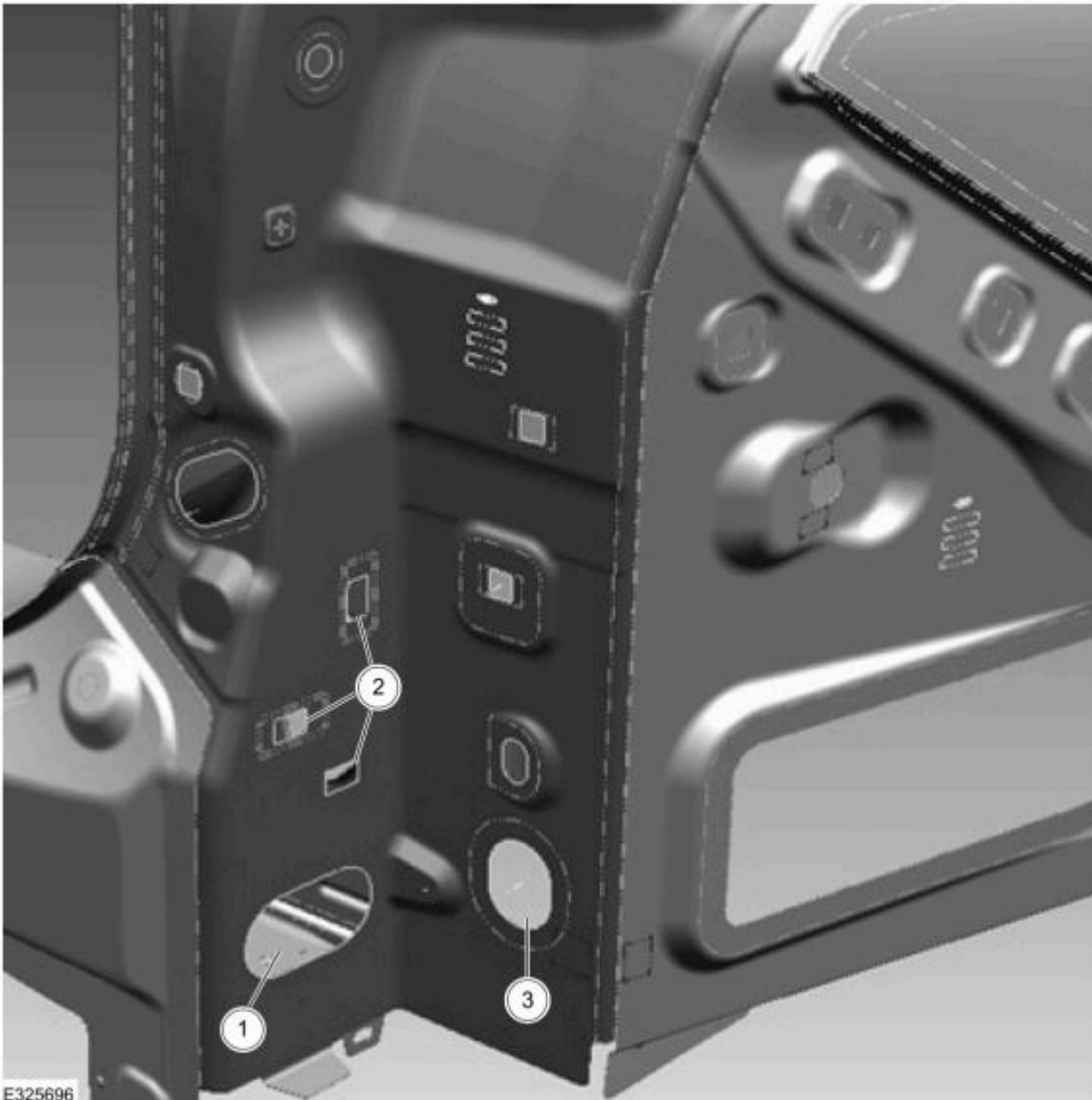

6. Inspect the left side rear corner area under the rear bumper cover for the following loose, disconnected, or missing items:

- (1). Visually inspect for delete tape completely covering the body hole. (Figures 7-9 Callout 1) If the tape is damaged or leaking, replace with a rubber plug.
- (2). Press down on the BLIS module to make sure it is fully seated into the body. (Figures 7-9 Callout 2)
- (3). Visually inspect the BLIS module wire harness grommet is seated. (Figures 7-9 Callout 3)

Figure 7

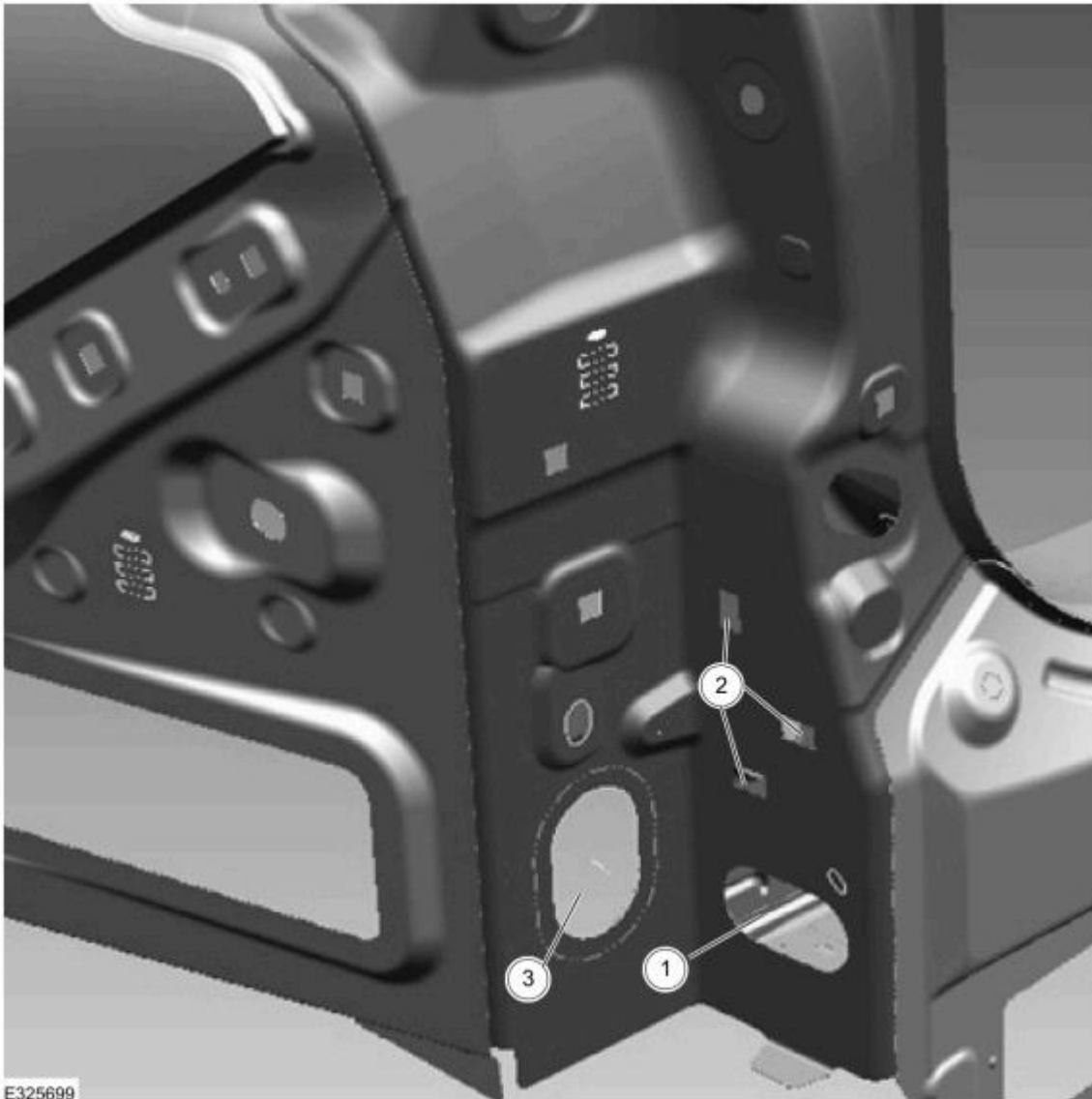

Figure 8



E325698

Figure 9



Aviator Vehicle Inspection

1. Open the rear liftgate.
2. Inspect and make sure the following components are correctly seated by pushing:
 - (1). Power liftgate grommet. If not properly seated, replace the affected power liftgate strut. (Figure 10 Callout 1, Figure 11)
 - (2). Margin seal and margin seal pushpins. (Figure 10 Callout 2)
 - (3). Electrical wiring grommet. (Figure 10 Callout 3)
 - (4). Rear washer hose. (Figure 10 Callout 4)

Figure 10

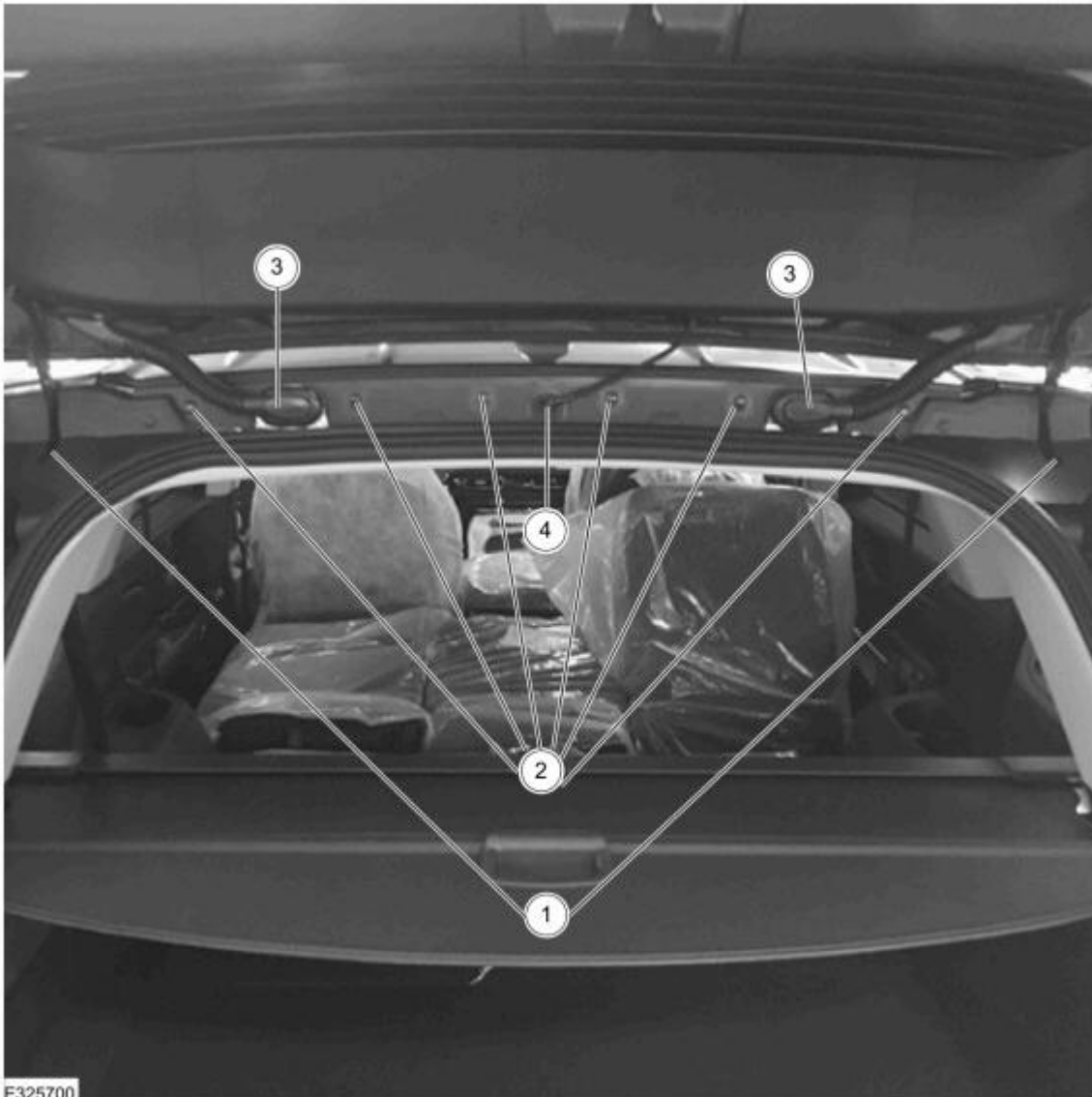

E325700

Item	Description
1	Power liftgate grommet
2	Margin seal and margin seal pushpins
3	Electrical wiring grommet
4	Rear washer hose

Figure 11



3. If a water leak is present on the right side of the vehicle, replace the ACM.

(1). Reinstall the rain shield (if equipped) on the new ACM. The rain shield, if present, is attached to the ACM chassis using a pushpin which can be reused.

4. Raise the vehicle on a hoist.

5. Inspect the right side rear corner area under the rear bumper cover for the following loose, disconnected or missing items:

(1). Visually inspect for delete tape completely covering the body hole. (Figures 12-14 Callout 1) If the tape is damaged or leaking, replace with a rubber plug.

(2). Press down on the BLIS module to make sure it is fully seated into the body. (Figures 12-14 Callout 2)

(3). Visually inspect the BLIS module wire harness grommet is seated. (Figures 12-14 Callout 3)

(4). Make sure the wire harness grommet for the phone as a key feature is seated or the delete tape is completely covering the body hole. (Figures 12-14 Callout 4) If the tape is damaged or leaking, replace with a rubber plug.

(5). BLIS grommet to module wire. (Figures 12-14 Callout 5)

Figure 12

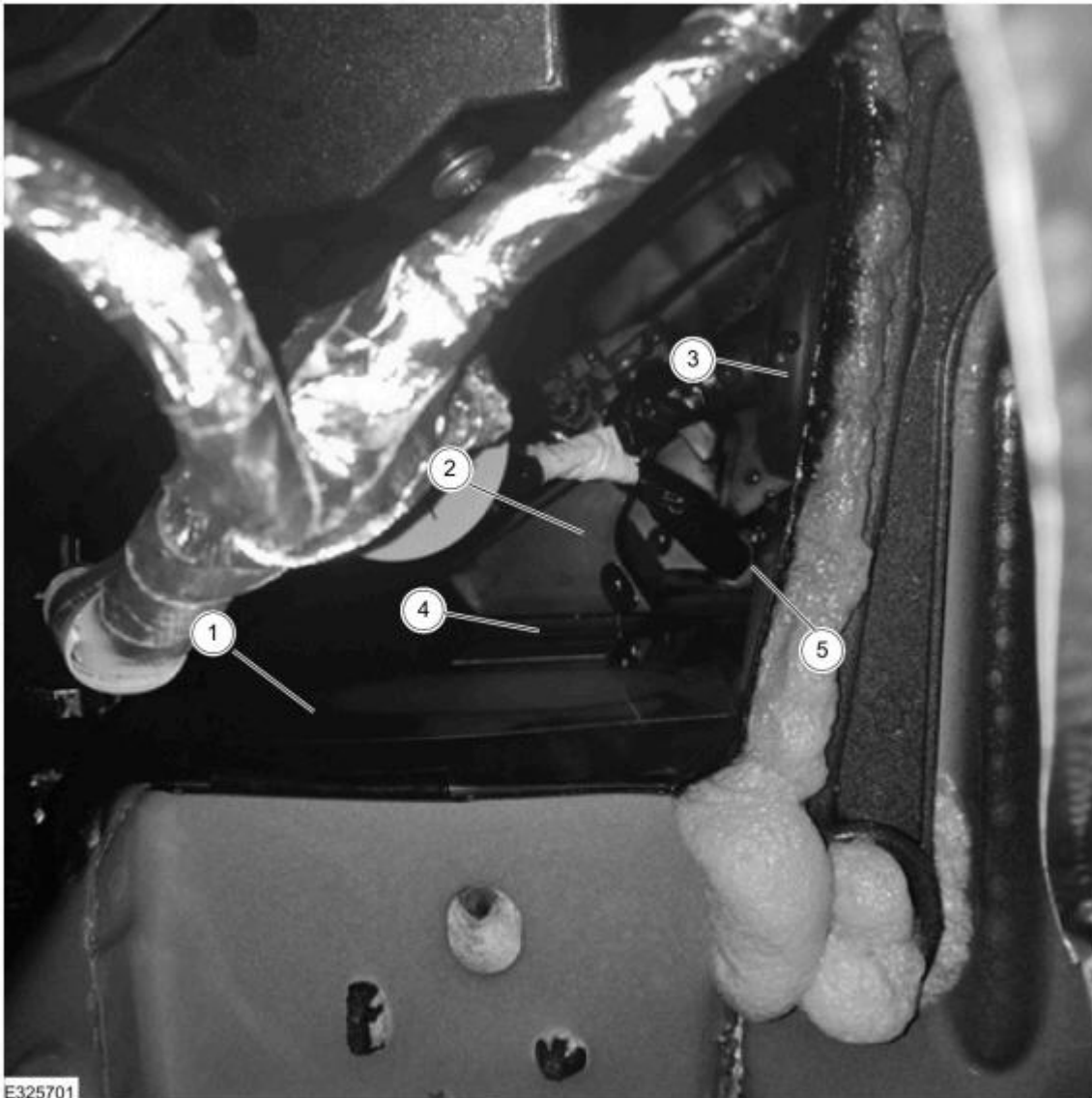
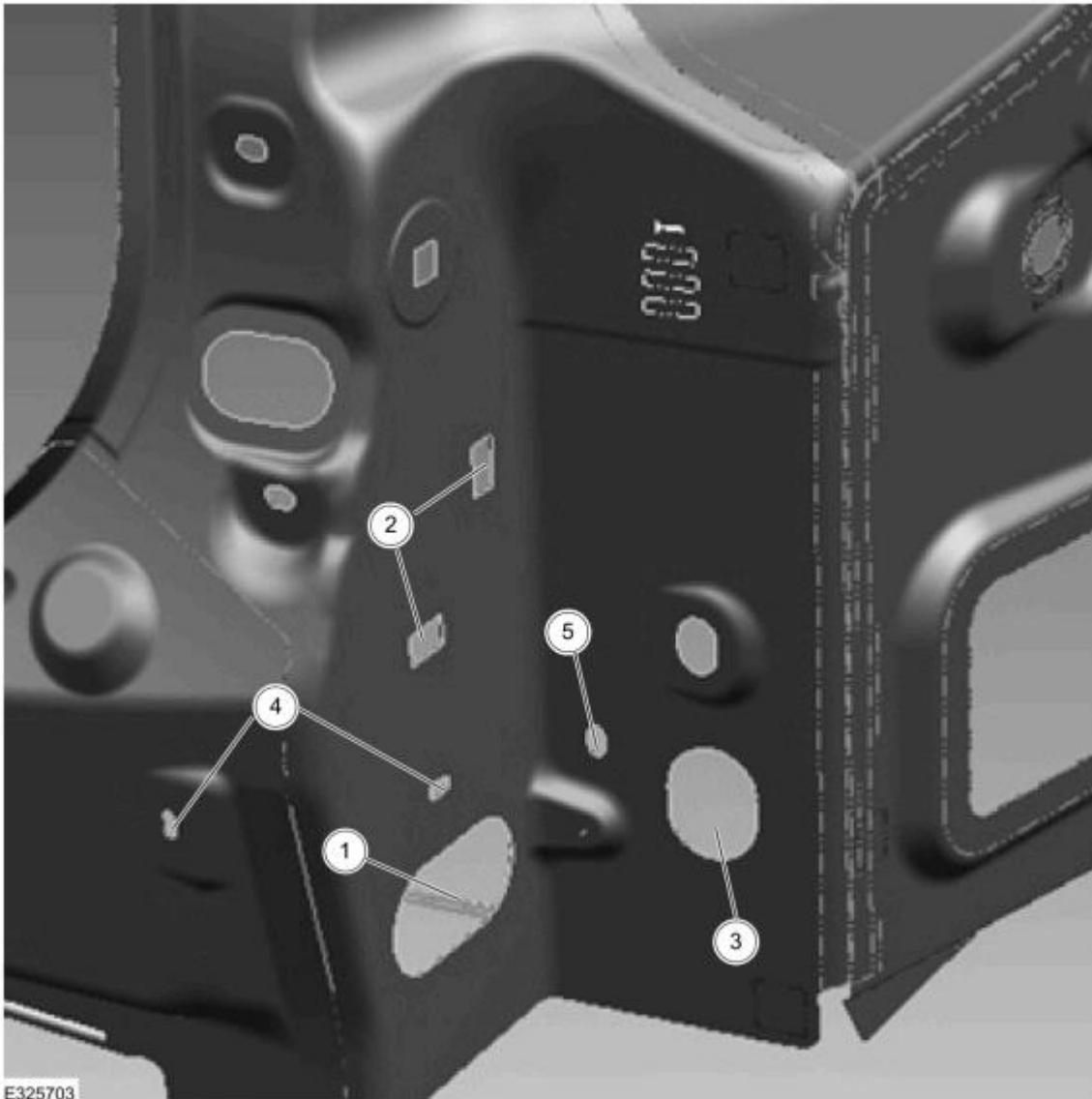

Figure 13



6. Inspect the left side rear corner area under the rear bumper cover for the following loose, disconnected or missing items:

- (1). Visually inspect for delete tape completely covering the body hole. (Figures 15-17 Callout 1) If the tape is damaged or leaking, replace with a rubber plug.
- (2). Press down on the BLIS module to make it is fully seated into the body. (Figures 15-17 Callout 2)
- (3). Visually inspect the BLIS module wire harness grommet is seated. (Figures 15-17 Callout 3)
- (4). Make sure the wire harness grommet for the phone as a key feature is seated or the delete tape is completely covering the body hole. (Figures 15-17 Callout 4) If the tape is damaged or leaking, replace with a rubber plug.
- (5). Rear fascia wire. (Figures 15-17 Callout 5)

Figure 15

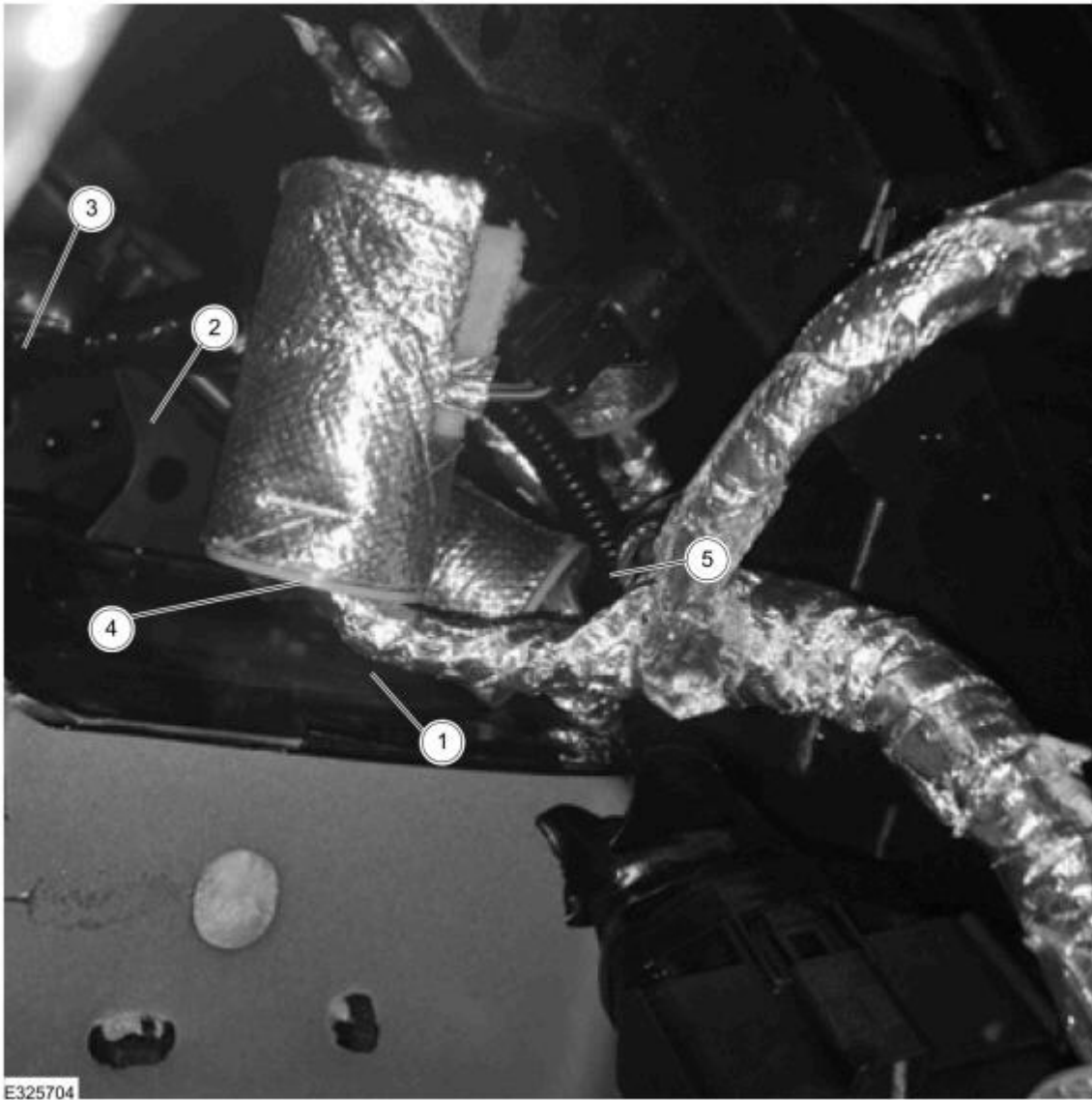
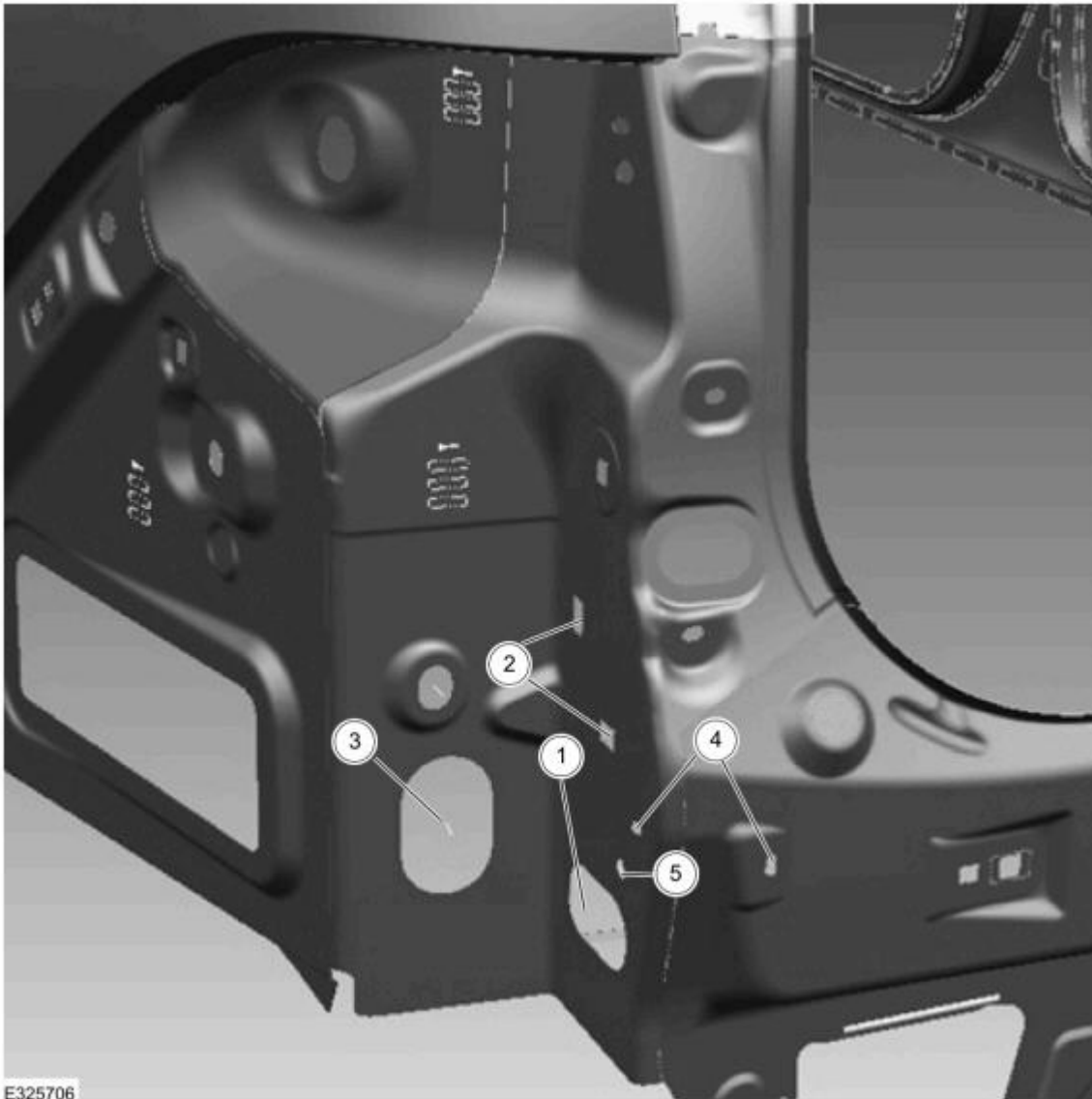

Figure 16



© 2024 Ford Motor Company
All rights reserved.

NOTE: The information in Technical Service Bulletins is intended for use by trained, professional technicians with the knowledge, tools, and equipment to do the job properly and safely. It informs these technicians of conditions that may occur on some vehicles, or provides information that could assist in proper vehicle service. The procedures should not be performed by "do-it-yourselfers". Do not assume that a condition described affects your car or truck. Contact a Ford or Lincoln dealership to determine whether the Bulletin applies to your vehicle. Warranty Policy and Extended Service Plan documentation determine Warranty and/or Extended Service Plan coverage unless stated otherwise in the TSB article. The information in this Technical Service Bulletin (TSB) was current at the time of printing. Ford Motor Company reserves the right to supersede this information with updates. The most recent information is available through Ford Motor Company's on-line technical resources.