

ATTENTION:

- GENERAL MANAGER
- PARTS MANAGER
- CLAIMS PERSONNEL
- SERVICE MANAGER

IMPORTANT - All Service Personnel Should Read and Initial in the boxes provided, right.

© 2023 Subaru of America, Inc. All rights reserved.



QUALITY DRIVEN® SERVICE

SERVICE BULLETIN

APPLICABILITY: 2019MY Legacy & Outback
2019-21MY WRX

NUMBER: 15-318-24R

DATE: 02/23/24

SUBJECT: Data Communication Module (DCM) Bypass Box

REVISED: 03/19/24

INTRODUCTION:

This bulletin announces the availability of the DCM Bypass Box designed to be used as an alternative replacement part for Data Communication Module (DCM) in vehicles with no active STARLINK subscription. If the diagnosis leads to the replacement of the DCM, the DCM Bypass Box can be used in place of a DCM to support audio input/output functions for infotainment system.

PART INFORMATION:

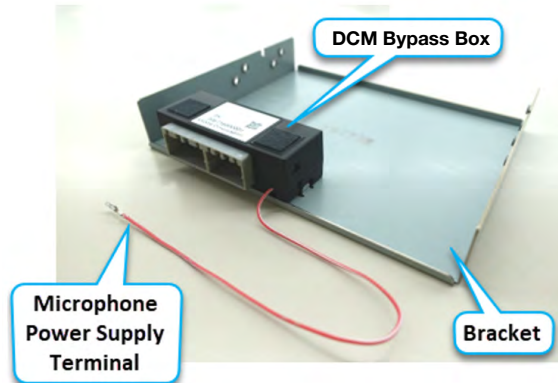

Part Description	Part Number
DCM BYPASS BOX	86229AL400

STARLINK SUBSCRIPTION CONFIRMATION:

This DCM Bypass Box installation is for vehicles without any active STARLINK subscription. ALWAYS confirm the STARLINK subscription status prior to performing the DCM bypass box installation. This bypass box (86229AL400) is **ONLY** orderable through PRIME. There is no need to contact PICs for release.

NOTE: If the vehicle has an active STARLINK subscription a Data Communication Module must be used as replacement part. Please contact SOA PICs team after placing the order through the normal ordering channels with the VIN and order number to have the VIN verified for the subscription and have the order released.

<p>CAUTION: VEHICLE SERVICING PERFORMED BY UNTRAINED PERSONS COULD RESULT IN SERIOUS INJURY TO THOSE PERSONS OR TO OTHERS.</p> <p>Subaru Service Bulletins are intended for use by professional technicians ONLY. They are written to inform those technicians of conditions that may occur in some vehicles, or to provide information that could assist in the proper servicing of the vehicle. Properly trained technicians have the equipment, tools, safety instructions, and know-how to do the job correctly and safely. If a condition is described, DO NOT assume that this Service Bulletin applies to your vehicle, or that your vehicle will have that condition.</p>	<p style="text-align: center;">Subaru of America, Inc. is ISO 14001 Compliant</p> <p>ISO 14001 is the international standard for excellence in Environmental Management Systems. Please recycle or dispose of automotive products in a manner that is friendly to our environment and in accordance with all local, state and federal laws and regulations.</p>
--	--

Continued...

CONFIRMING SUBSCRIPTION STATUS USING SNET VEHICLE INQUIRY:

1. Enter the subject Vehicle Identification Number (VIN) into the VIN search box and click the search button.

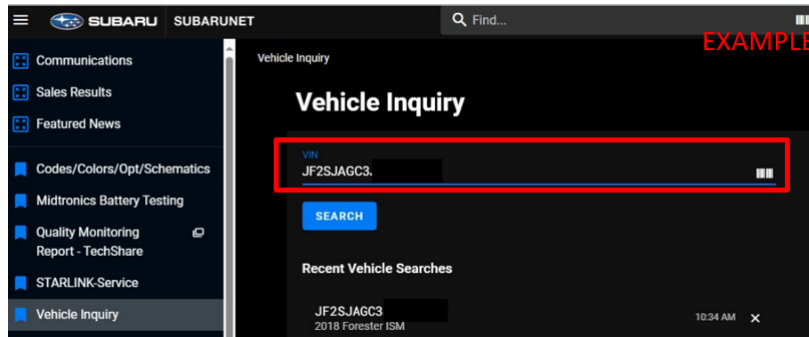

2. Select the Connected Vehicle Subscriptions drop down.

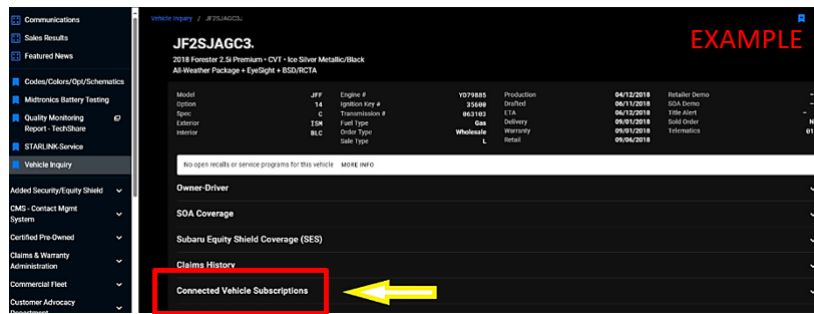

3. Confirm the status reads “Inactive” prior to proceeding. If the status reads “Active,” the vehicle has an active STARLINK subscription and does not qualify for the repair procedures outlined in this bulletin.

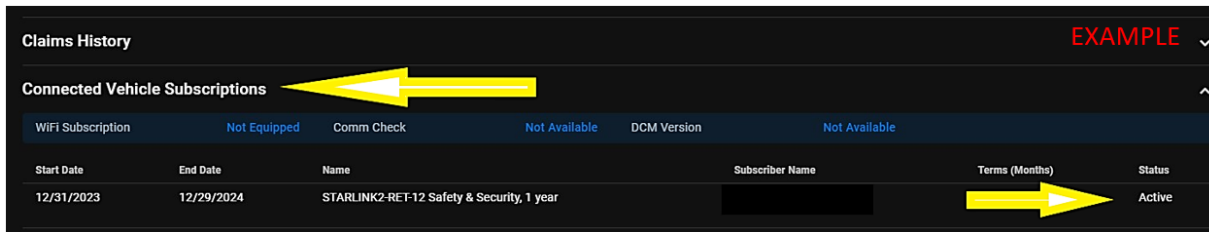

CONFIRMING SUBSCRIPTION STATUS USING SUBARU SELECT MONITOR:

4. Connect the applicable Subaru Select Monitor (SSM) to the vehicle. Read the Subscription status of the DCM located in the “Work Support” menus. Confirm the subscription status reads “Unsubscribed” prior to proceeding. If the status reads “Subscribed,” the vehicle has an active STARLINK subscription and does not qualify for the repair procedures outlined in this bulletin.

EXAMPLE	Item	Value
✓	Subscription Status	Subscribed
✓	Remote Battery Charging Timer Active	TRUE
✓	Curfew Active	TRUE
✓	Driving Recorder Active	TRUE

Continued...

DCM BYPASS BOX INSTALLATION CONFIGURATION:

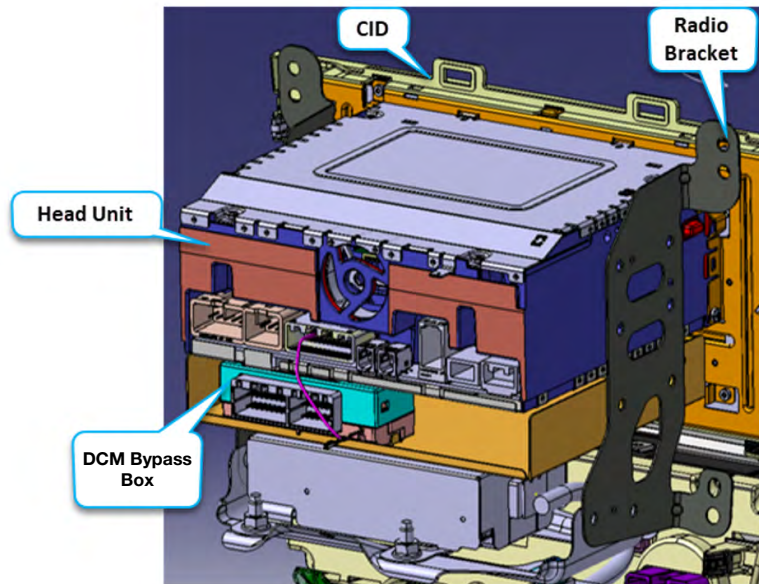

LEGACY & OUTBACK DCM REMOVAL PROCEDURE / INFORMATION:

IMPORTANT: This procedure is for vehicles without any active STARLINK subscription. ALWAYS confirm the STARLINK subscription status prior to performing the procedures outlined below.

STEP 1: Refer to the applicable Service Manual and review: General Description > Repair Contents > Action required before & after Battery Disconnect. Additionally, record any stored seat position(s) before proceeding. Relearn any seat position memory after work is complete. If the power rear gate (PRG) height has been customized, that position must also be noted and relearned.

STEP 2: CAREFULLY disconnect the battery sensor from the negative ground terminal and wait at least 60 seconds before continuing.

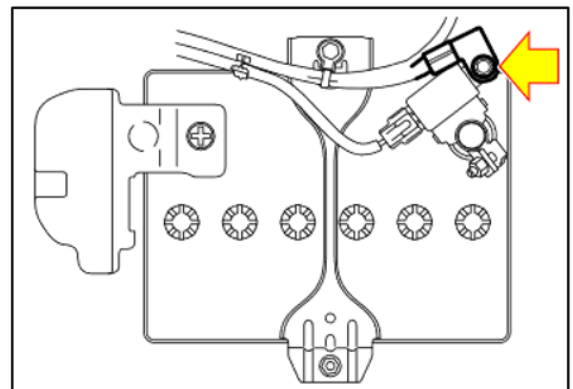

STEP 3: Remove the Center Grille Assembly.

- A. Release the clips and claws.
- B. Disconnect the connector and remove the Grille Assembly.
- C. Disconnect and remove the hazard switch.

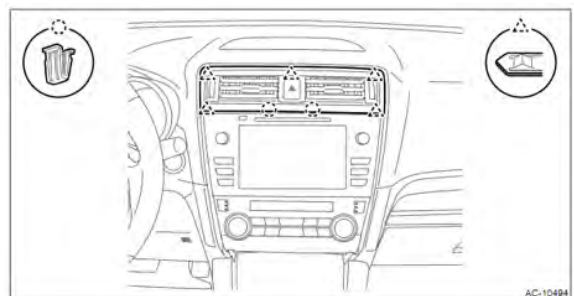

Continued...

STEP 4: Remove the Heater Control Assembly.

- A. Release the clips and claws.
- B. Remove the panel.
- C. Remove the mounting screws.
- D. Detach the heater control assembly.

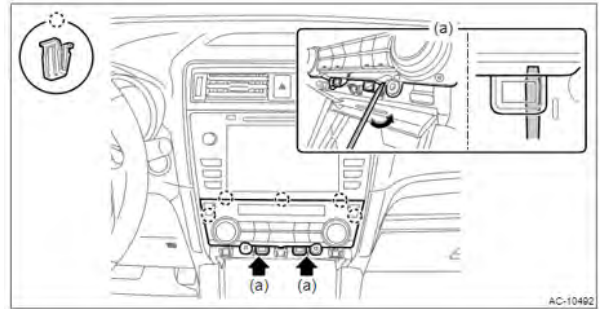

CAUTION: A flat head screwdriver with protective tape can be used as shown in the right image. Use special care to not damage the heater control assembly.

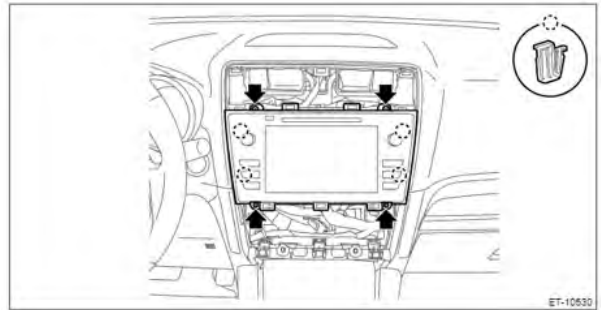

STEP 5: Remove the audio assembly.

- A. Remove the mounting screws.
- B. Release the mounting clips.
- C. Disconnect all electrical connections.
- D. The audio assembly can then be removed.

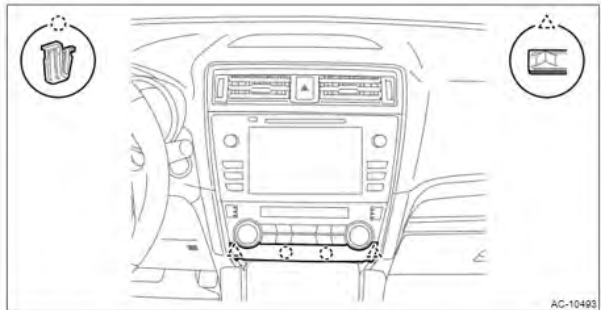

STEP 6: Remove the DCM.

- A. CAREFULLY remove the bracket mounting screws.
- B. Remove the DCM and the backup module assembly together.

CAUTION: Be mindful to not cause any damage to the mounting screws during removal. The mounting screws are to be reused.

STEP 7: Refer to the DCM Bypass Box Installation section of this bulletin on page #8.

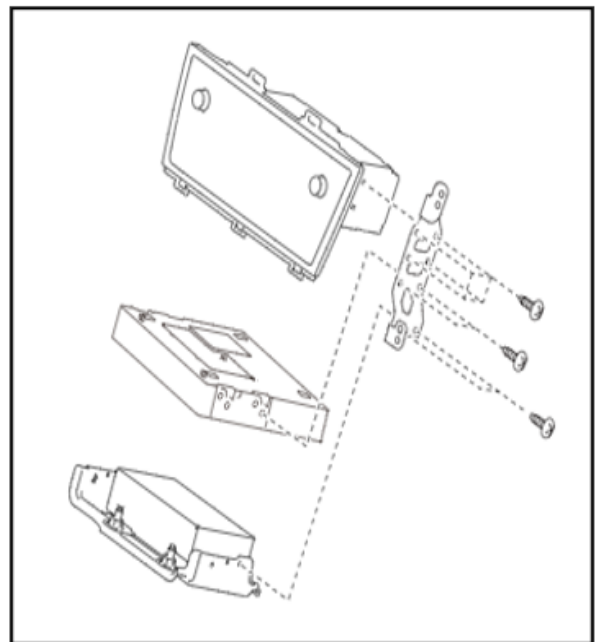

Continued...

WRX DCM REMOVAL PROCEDURE / INFORMATION:

IMPORTANT: This procedure is for vehicles without any active STARLINK subscription. ALWAYS confirm the STARLINK subscription status prior to performing the procedures outlined below.

STEP 1: Refer to the applicable Service Manual and review: General Description > Repair Contents > Action required before & after Battery Disconnect. Additionally, record any stored seat position(s) before proceeding. Relearn any seat position memory after work is complete. If the power rear gate (PRG) height has been customized, that position must also be noted and relearned.

STEP 2: CAREFULLY disconnect the battery sensor from the negative ground terminal and wait at least 60 seconds before continuing.

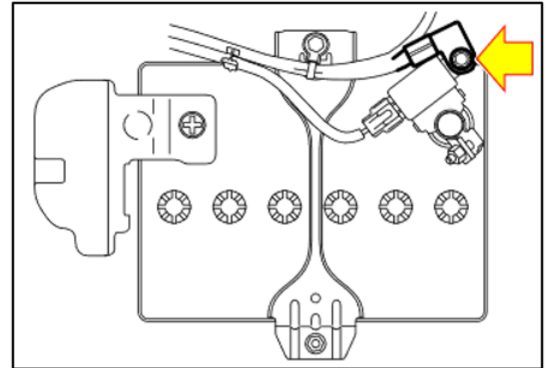

STEP 3: Using a plastic trim tool, remove the left side instrument panel cover.

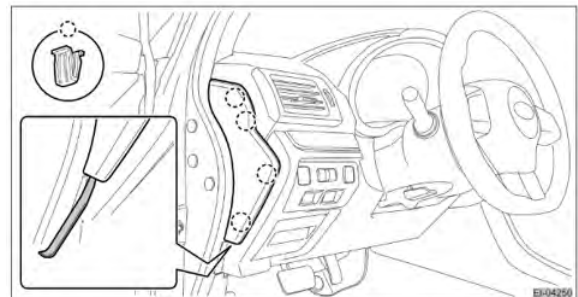

STEP 4: Remove the left inner and outer lower instrument panels.

- A. Remove the mounting screws.
- B. Release the mounting clips and claws.
- C. Pull both panels toward the rear of the vehicle.
- D. Disconnect all electrical connections.

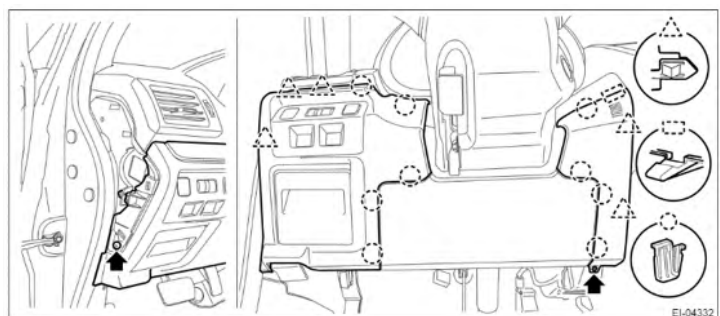

Continued...

CAUTION: ALWAYS pull the panels toward the rear of the vehicle. Pulling in an upward or downward direction may cause damage to the mounting claws.

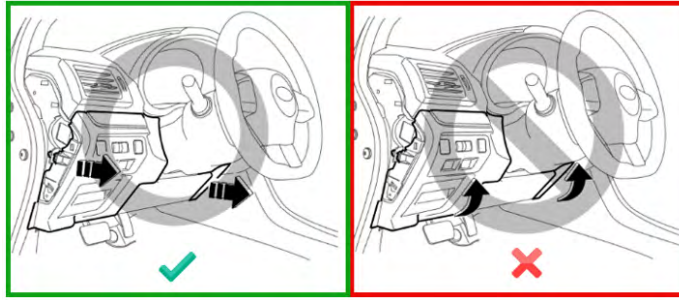

STEP 5: Remove the knee airbag module.

- A. Remove the mounting nuts.
- B. CAREFULLY disconnect the electrical connection.

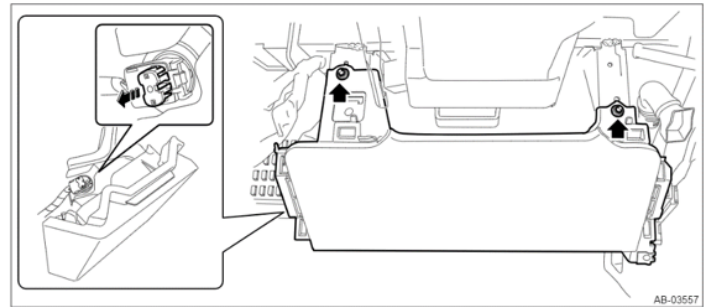

STEP 6: Remove the glove box assembly.

- A. Apply protective tape to the lower center panel section shown as (a) in the right image.
- B. Disconnect the damper from the glove box.
- C. Release the stoppers and pull the glove box toward the rear of the vehicle.

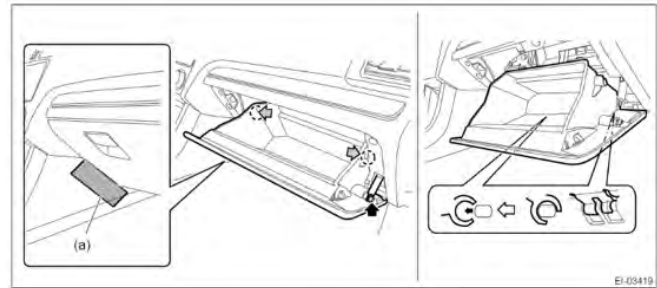

STEP 7: Remove the glove box backing panel.

- A. Using a plastic trim tool, remove the right side instrument panel cover.
- B. Release the clips and removed the instrument panel ornamental trim.

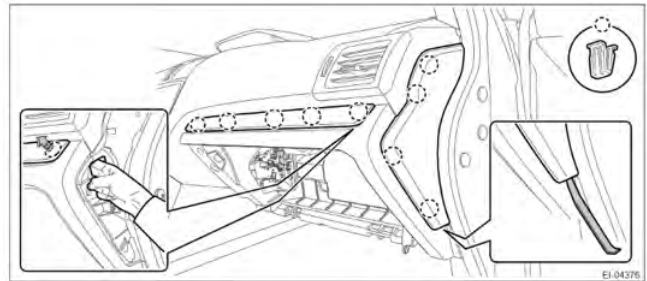

TIP: The instrument panel ornamental trim can be removed by applying pressure from the backside.

- C. Remove the glove box LED and disconnect the electrical connection.
- D. Removed the mounting screws.
- E. Release the claws and harness clamp.
- F. The glove box backing panel can then be removed.

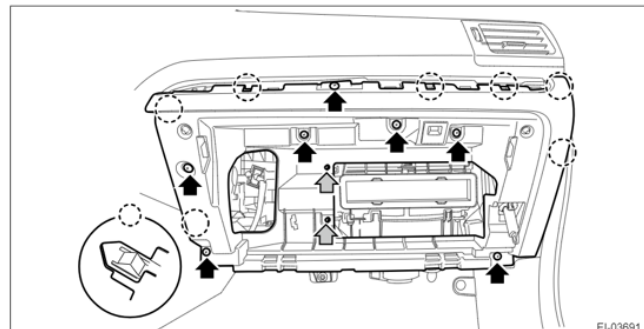

Continued...

STEP 8: Remove the center grille assembly.

- A.** Apply protective tape to the instrument panel section shown as (a) in the right image.
- B.** Release the claw using a plastic trim tool or a clip removal tool with protective tape applied to the contact area.
- C.** Disconnect the electrical connector and remove the center grille assembly.

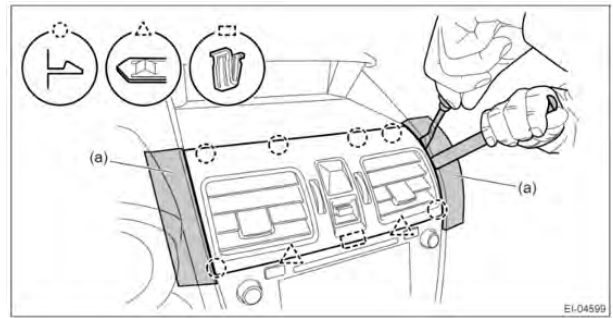

STEP 9: Remove the audio assembly.

- A.** Apply protective tape to the center storage area section indicated as (a) in the lower right image.
- B.** Remove the mounting screws and bolts.
- C.** Release the mounting claws and partially remove the audio assembly to gain access to the electrical connections.

CAUTION: If the antenna cable interferes with the removal side mounting bolts, move the antenna cable before attempting to remove the bolts.

- D.** Disconnect the electrical connectors and remove the audio assembly.

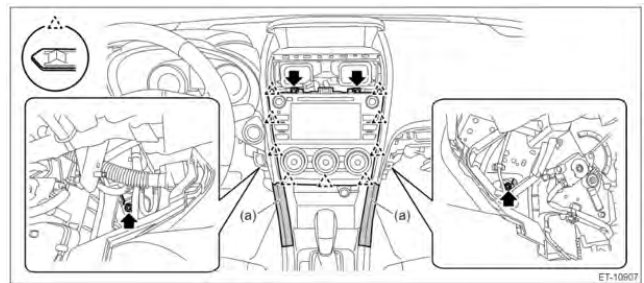

STEP 10: Remove the DCM.

- A.** CAREFULLY remove the bracket mounting screws.
- B.** Remove the DCM and the backup module assembly together.

CAUTION: Be mindful to not cause any damage to the mounting screws during removal. The mounting screws are to be reused.

STEP 11: Refer to the DCM Bypass Box Installation section of this bulletin on page #8.

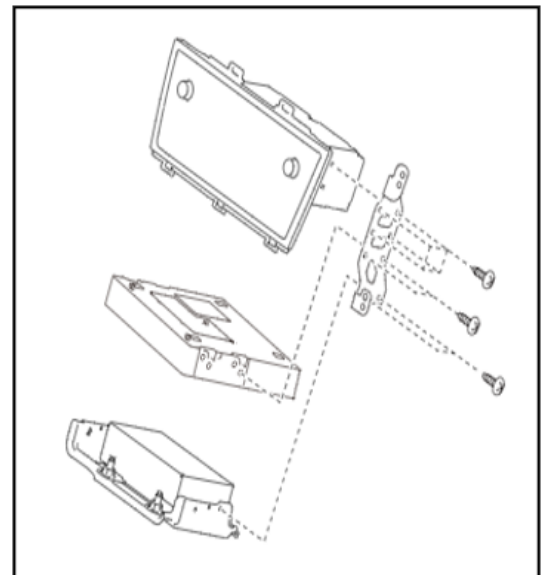

Continued...

DCM BYPASS BOX INSTALLATION:

STEP 1: Mount the DCM Bypass Box with the brackets in place of the DCM.

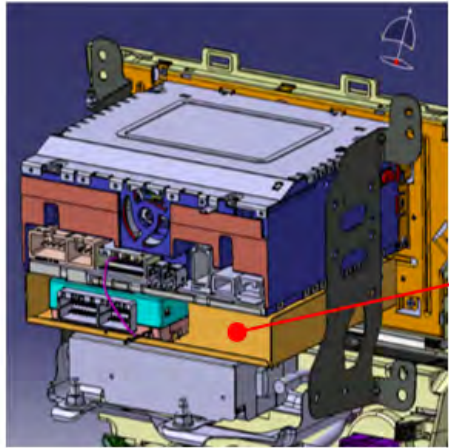

Back Side View

On LEGACY & OUTBACK, the lower mounting holes labeled with "←LEGACY/OUTBACK" are to be used.

On WRX, the upper mounting holes labeled with "WRX→" are to be used.

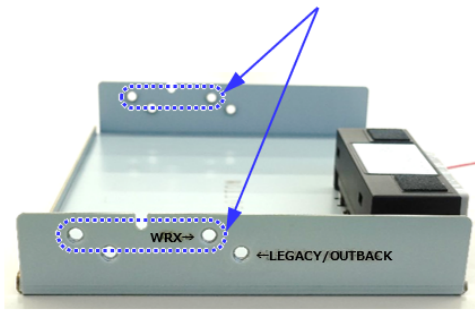
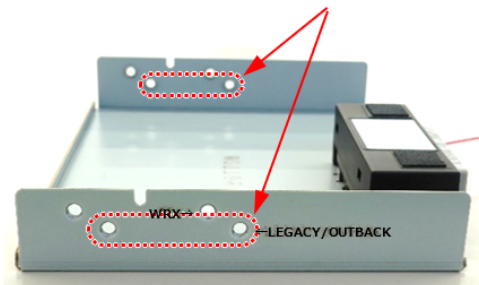

Left side of the DCM Bypass Box.

STEP 2: Locate pin #4 of head unit connector i87.

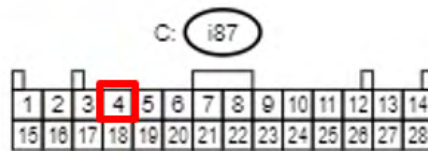
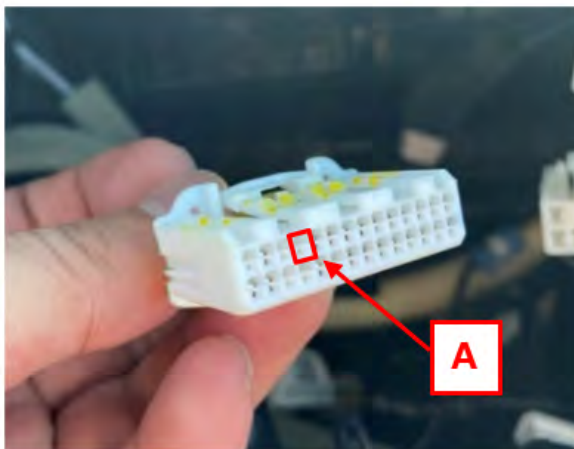

View from direction A

Continued...

STEP 3: Using a small precision screwdriver or pin terminal tool, release and raise the lock located on the back on the connector. The lock release points are located as (a) in the image below.

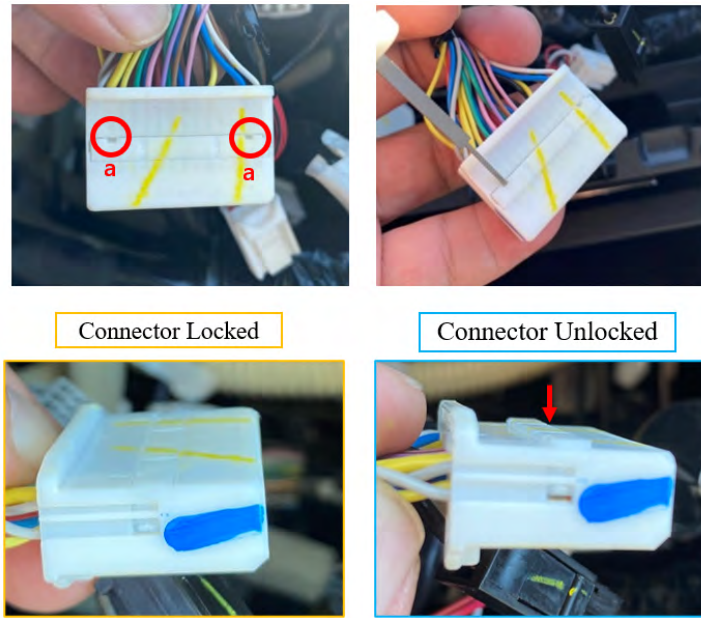

Connector Locked

Connector Unlocked

STEP 4: Insert the microphone power terminal into pin #4 of head unit connector i87.

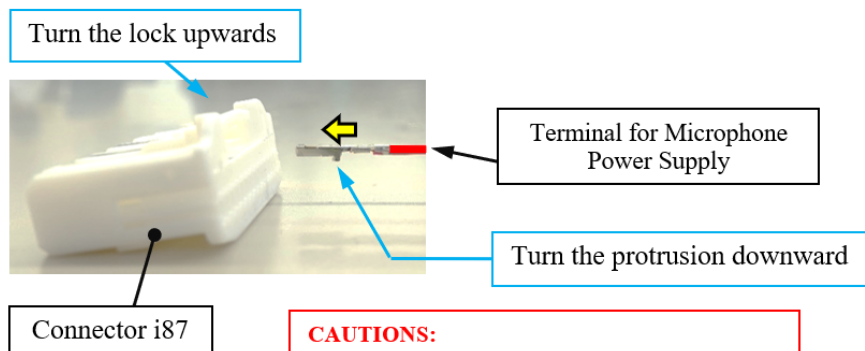
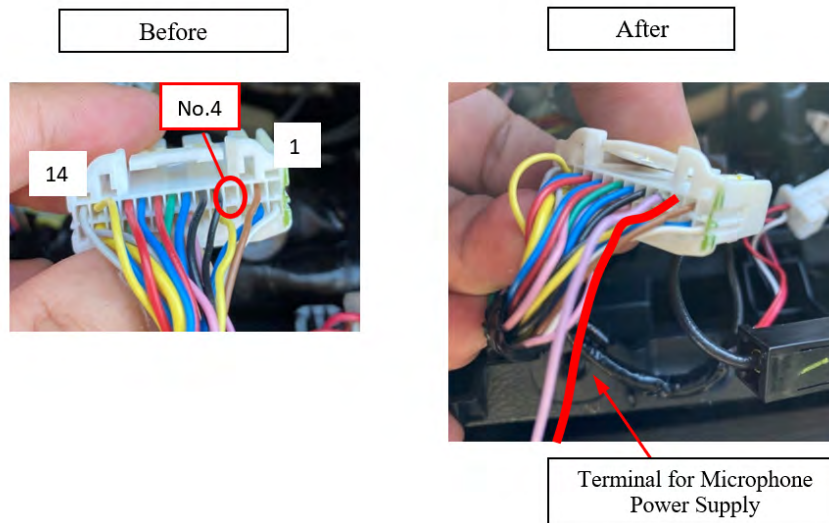

- CAUTIONS:**
- Pay attention to the direction of the terminals.
 - Insert from the same direction as other wires.

Continued...

STEP 5: Push the lock portion back into the connector. Confirm the connector is fully locked and the newly installed wire is secure.

Connector Fully Locked

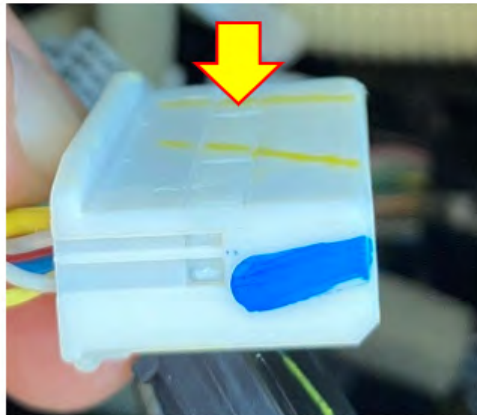

STEP 6: Secure the newly installed wire to the power harness with vinyl tape.

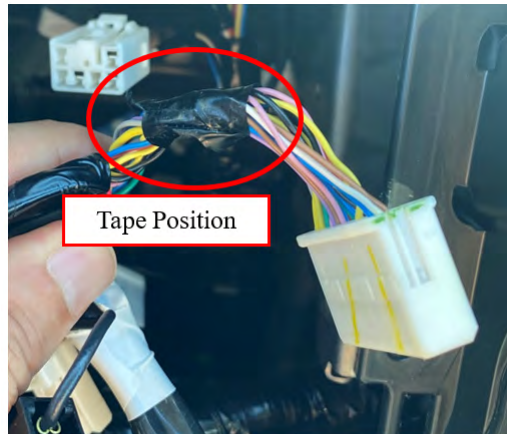

STEP 7: Bundle the reimagining three antenna connectors to +the harness with vinyl tape.



Continued...

STEP 8: Reinstall all parts in the reverse order of disassembly. Remove all protective tape.

IMPORTANT NOTE: Whenever reconnecting the ground cable terminal to the battery sensor, torque to 7.5Nm (5.5ft.-lbs. or 66inch-lbs.) while supporting the sensor with the other hand as outlined in the applicable Service Manual under: STARTING/CHARGING SYSTEMS > Battery Sensor.

STEP 9: Proceed to the Function Check portion of this bulletin on page #12.

FUNCTION CHECK:

STEP 1: Connect the Subaru Select Monitor (SSM) and perform and all systems fault scan. Confirm there are no DTCs.

STEP 2: Confirm sound is emitting from all the speakers. Pay special attention to the front tweeter speakers.

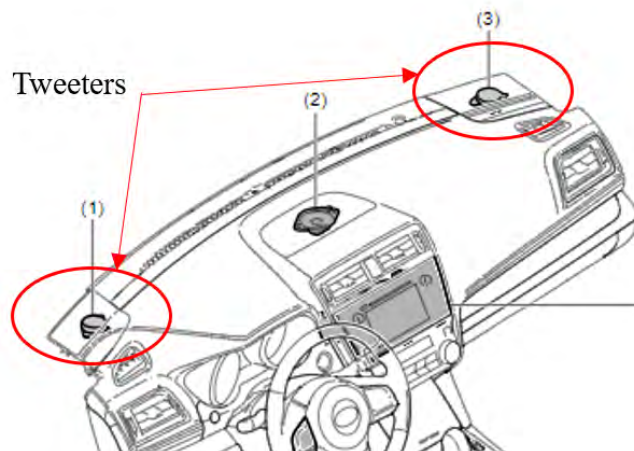

STEP 3: Confirm the microphone is working using the Service Diagnostics Mode.

- A. Turn the ignition switch to ACC.
- B. Press the “Tune/Scroll” knob six times while pressing the “HOME” button.
- C. Select “Function Check”.



Continued...

D. Select “Microphone”.

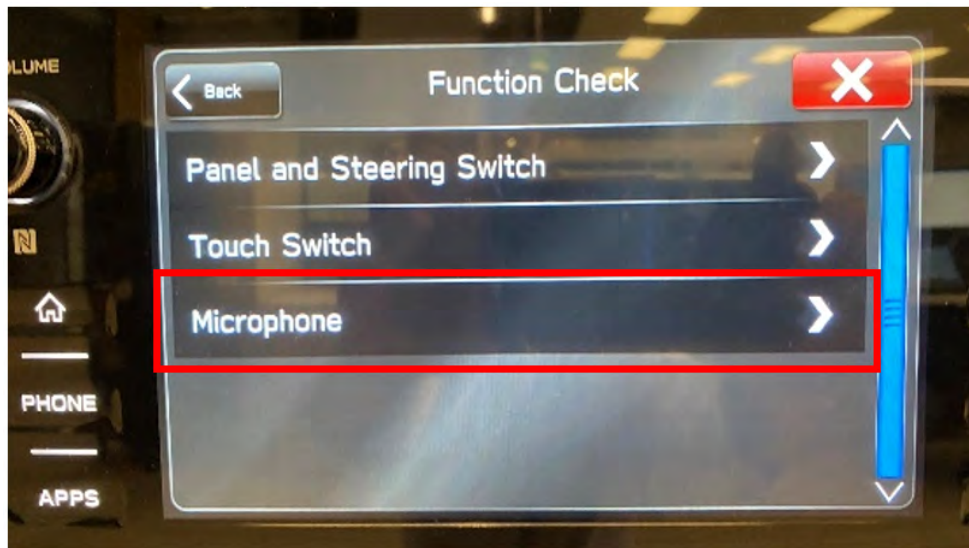

E. Confirm “Mic 1 Input Level” and “Mic 2 Input Level” are operational.

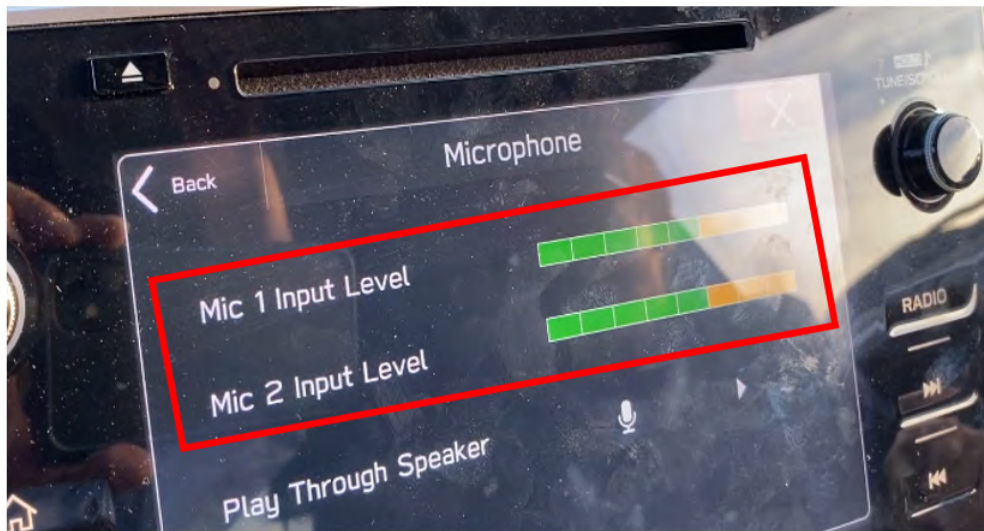

DCM RECONNECTION:

NOTE: DCM Reconnection is not part of the DCM bypass box placement procedure and need to be performed only if the customer with a DCM bypass box installed decides to subscribe to telematics services at some point in future.

In a case when STARLINK is to be re-subscribed for a vehicle with a DCM Bypass Box installed, the following procedure is required.

STEP 1: Disconnect the ground terminal from the battery sensor.

STEP 2: Remove the center grille assembly.

STEP 3: Remove the heater control assembly.

Continued...

STEP 4: Remove the audio assembly.

- A. Remove the screws and release the clip.
- B. Disconnect the connector and remove the audio assembly.
- C. Cut the microphone power wire (color: red) at the end of connector i87 pin #4.

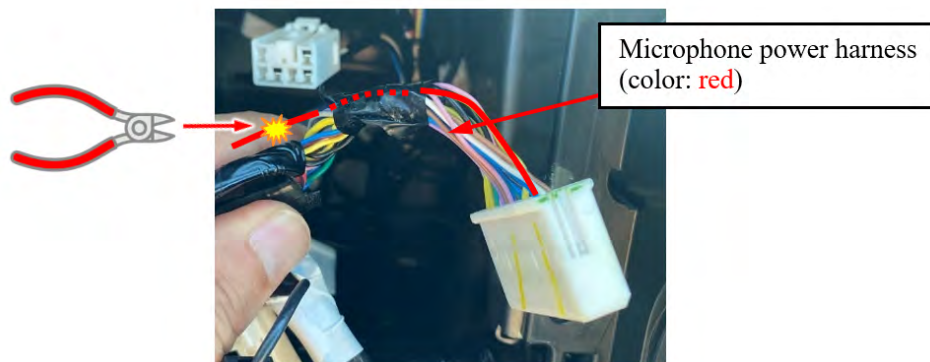

- D. Bundle the cut red wire for the microphone into the vehicle harness so the cut end is covered.

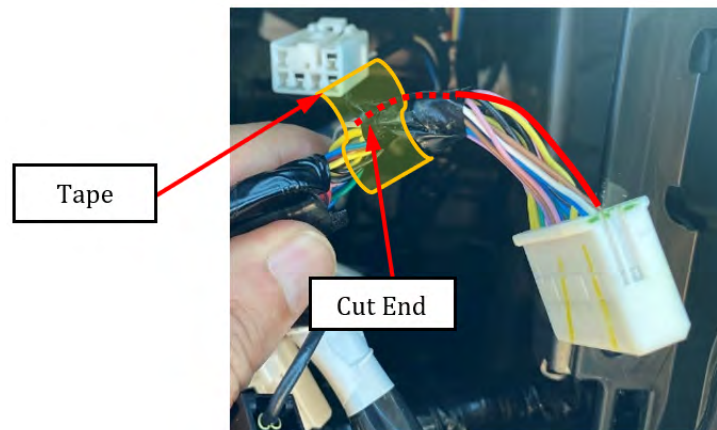

- E. Remove the tape from the three bundled antenna connectors.

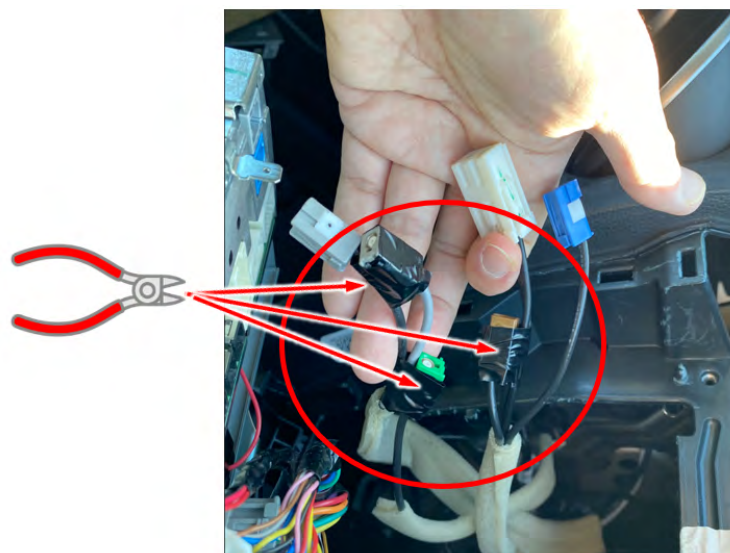

Continued...

STEP 5: Remove the DCM Bypass Box.

- A. CAREFULLY remove the mounting screws.
- B. Remove the DCM Bypass Box.

STEP 6: Install the DCM.

- A. Install the backup battery.
- B. Install the DCM.
- C. Install the audio assembly or navigation assembly.
- D. Install the heater control assembly.
- E. Install the center grille assembly.
- F. Connect the ground terminal to battery sensor. Refer to STIS: REPAIR CONTENTS > NOTE > BATTERY.
- G. Perform the registration procedure if the DCM is replaced with a new part. Refer to STIS: ENTERTAINMENT & MONITORING > Telematics System > OPERATION
- H. Check the LED lighting condition of the Telematics button. Refer to STIS: TELEMATICS SYSTEM > (DIAGNOSTICS) > Check List for Interview > CHECK > LED ILLUMINATION STATUS LIST

WARRANTY / CLAIM INFORMATION:

For vehicles within the Basic New Car Limited Warranty period or covered by an active Added Security Gold Plan, this repair may be submitted using the following claim information:

Labor Description	Labor Operation #	Labor Time	Fail Code
TEST AND REPLACE DCM WITH DCM BYPASS BOX	B067-915	1.1	TQQ-48

IMPORTANT REMINDERS:

- SOA strongly discourages the printing and/or local storage of service information as previously released information and electronic publications may be updated at any time.
- Always check for any open recalls or campaigns anytime a vehicle is in for servicing.
- Always refer to STIS for the latest service information before performing any repairs.