

Repairs for Roof Box Front Panel and Lights

Vehicle Type: **911 Dakar**

Model Year: **As of 2023**

Information: **Repairs**

Note: These instructions describe how to replace the light units and the front panel.
Depending on the damage, only the respective work steps are to be carried out.

Parts Info: **992.044.884**

Parts List:



Figure 1

Scope of the repair set (⇒ Figure 1):

- 992.044.891¹ 1 x Right light unit ⇒ Figure 1-1-
- 992.044.891¹ 1 x Left light unit ⇒ Figure 1-2-
- 992.044.889.A 1 x Front panel ⇒ Figure 1-3-
- 992.044.884¹ 1 x Adhesive tape ⇒ Figure 1-4-
- 992.044.884¹ 1 x Surface Cleaner Sachet (cleaning cloth) ⇒ Figure 1-5-
- 992.044.884¹ 1 x Adhesion promoter (primer) ⇒ Figure 1-6-

¹ 1) **Only** contained in respective set.

**Information**

The baggage carrier must be kept in a heated hall (> 10°C/ 50°F) for at least 5 hours.

**Information**

- Some of the repair illustrations show only one side of the vehicle.
- Naturally, some steps also have to be performed on the opposite side of the vehicle as well.

Removal:

- 1 Remove roof box from the vehicle and place it on a stable surface.
The roof box must be dry.

- 2 Removing front panel

To protect the component, attach adhesive tape to all transitions.

- 2.1 Unscrew screws ⇒ *Figure 2-2-* and carefully pull covers ⇒ *Figure 2-1-* back out of the latch towards the set corner.
Do not break off locking lugs, use mounting wedge / plastic spatula.

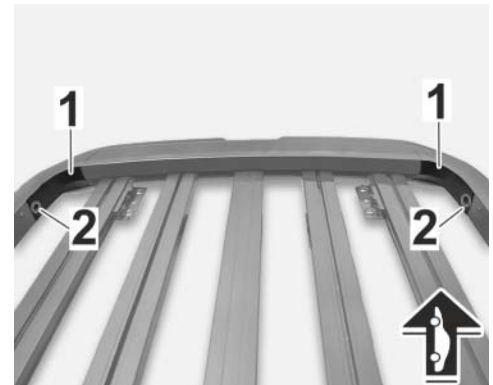

Figure 2

- 2.2 Unscrew screws ⇒ *Figure 3-1-* on roof box ⇒ *Figure 3-2-*.

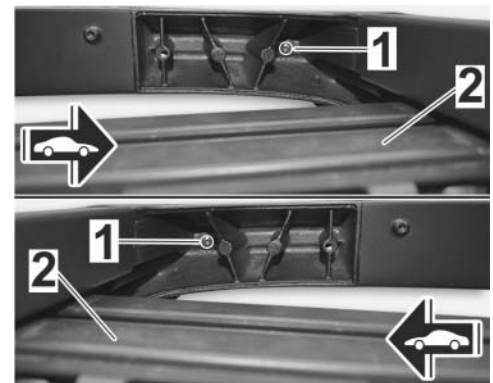
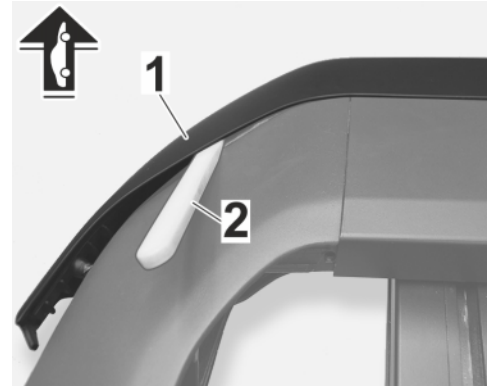
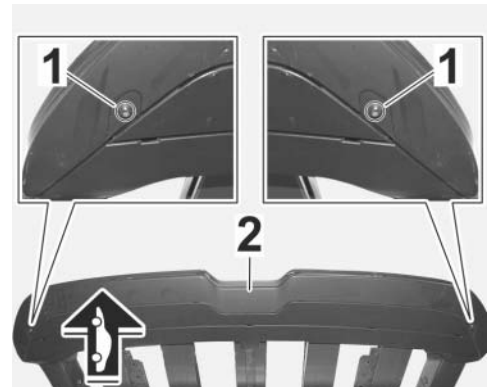

Figure 3

- 2.3 Carefully loosen adhesive straps along the front panel ⇒ *Figure 4-1-* with mounting wedge / plastic spatula ⇒ *Figure 4-2-*.
- 2.4 Place roof box on the top side.
Get a second person to help.

*Figure 4*

- 2.5 Unscrew screws ⇒ *Figure 5-1-* on front panel ⇒ *Figure 5-2-*.

*Figure 5*

- 2.6 Carefully loosen adhesive straps along the front panel ⇒ *Figure 6-1-* with mounting wedge / plastic spatula ⇒ *Figure 6-2-* and ⇒ *Figure 6-1-* remove panel.

- 3 Removing light bulb
This work step can be skipped if only the front panel is replaced.

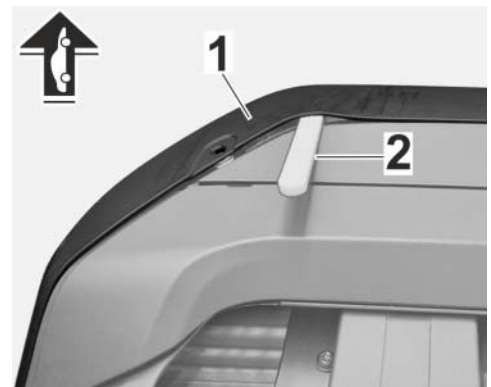
*Figure 6*

- 3.1 Loosen both screws \Rightarrow *Figure 7-1-* on each of the light units \Rightarrow *Figure 7-2-* and remove light units \Rightarrow *Figure 7-2-*.

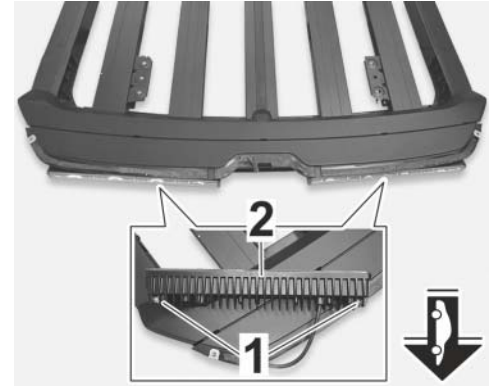

Figure 7

- 3.2 Disconnect cable ties \Rightarrow *Figure 8-1-*, disconnect plug \Rightarrow *Figure 8-2-* and remove light unit \Rightarrow *Figure 8-3-*.

Installation:

4 Preparing for installation

- 4.1 Remove adhesive residues on the front panel using a film eraser.

This work step can be skipped if the front panel is replaced.

- 4.2 Remove adhesive residues on the roof box with eraser.

- 4.3 Brush all adhesive surfaces with sandpaper (120 grain).

- 4.4 Clean and degrease adhesive points using the supplied "Surface Cleaner Sachet" (cleaning cloth)

- 4.5 Apply "Adhesion Promoter" (primer) to adhesive points.
Allow to dry for 3–5 minutes.

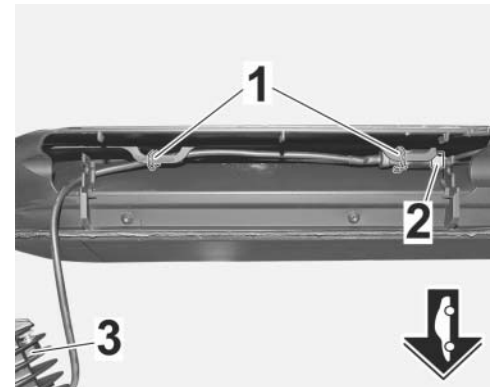

Figure 8

5 Installing light units

This work step can be skipped if only the front panel is replaced.

- 5.1 Install light units in reverse order \Rightarrow 3.
Make sure that both washers are placed between the screw head and light unit.

Tightening torque 3 Nm (2.2 ftlb.)

6 Installing front panel

6.1 Attach adhesive strips ⇒ *Figure 9-1*- to roof box and pull off and secure the protective film one area at a time ⇒ *Figure 9-2*-.

6.2 Place roof box on the bottom side. Get a second person to help.

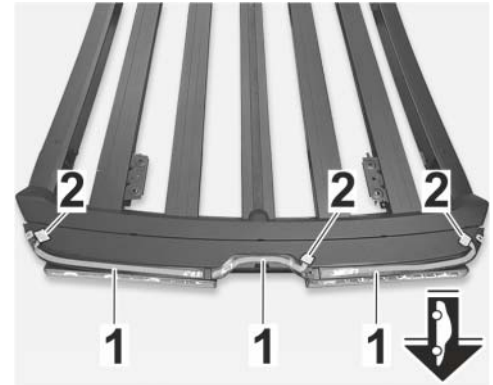

Figure 9

6.3 Attach adhesive strips ⇒ *Figure 10-1*- to roof box and pull off and secure the protective film one place at a time ⇒ *Figure 10-2*-.

6.4 Install front panel. **Ensure even joints & transitions to the roof box.**

6.5 Carefully pull off the protective films of the adhesive strips and press on the front panel.

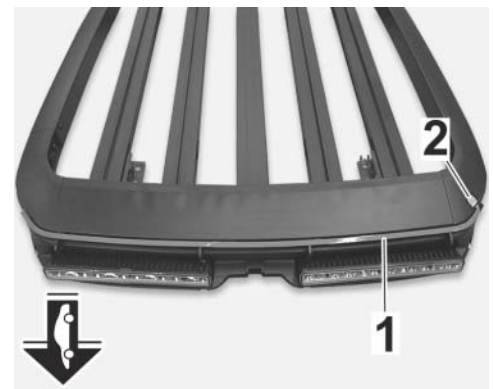

Figure 10

6.6 Screw in screws ⇒ *Figure 5-1*- on the ⇒ *Figure 5-2*- lower side of front panel.

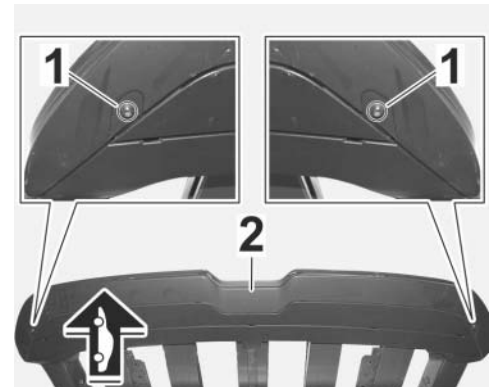

Figure 5

- 6.7 Screw in screws ⇒ *Figure 3-1-* on roof box
⇒ *Figure 3-2-*.

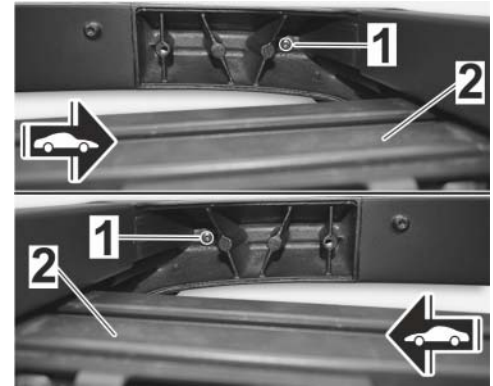

Figure 3

- 6.8 Install panels ⇒ *Figure 2-1-* and screw in
screws ⇒ *Figure 2-2-*.

- 7 Install roof box on vehicle.

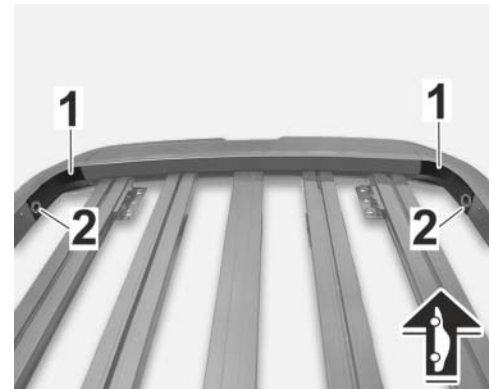

Figure 2

66924140	66924140 — Repairing roof box front panel Includes: Remove and install front panel.	Labor time: 50 TU
66924145	66924145 — Repairing roof box front panel and lights Includes: Replace front panel. Replace light.	Labor time: 180 TU

Important Notice: Technical Bulletins issued by Porsche Cars North America, Inc. are intended only for use by professional automotive technicians who have attended Porsche service training courses. They are written to inform those technicians of conditions that may occur on some Porsche vehicles, or to provide information that could assist in the proper servicing of a vehicle. Porsche special tools may be necessary in order to perform certain operations identified in these bulletins. Use of tools and procedures other than those Porsche recommends in these bulletins may be detrimental to the safe operation of your vehicle, and may endanger the people working on it. Properly trained Porsche technicians have the equipment, tools, safety instructions, and know-how to do the job properly and safely. Part numbers listed in these bulletins are for reference only. The work procedures updated electronically in the Porsche PIWIS diagnostic and testing device take precedence and, in the event of a discrepancy, the work procedures in the PIWIS Tester are the ones that must be followed.

© 2024 Porsche Cars North America, Inc.