

## LOW SPEED DRIVEABILITY – 2.0L/P4 AND 3.0L/P6

### Customer Voice:

- Lack of power, MIL light on, rough idle

### Technical Description:

- PCM, P052A-00, P054A-00, P0014-71 exhaust camshaft position timing codes might possibly be set.

### Status:

- When using the workflow for the above codes. the VVT solenoids should be checked along with the VVT bolts for any damage.
- Instructions are to replace both solenoids and bolts.
- Please open an EPQR if you have any vehicles with this condition.

#### Discovery

- 20-23MY Discovery

#### Jaguar

- 20-23MY F-PACE

#### Defender

- 20-23MY Defender

#### Range Rover

- 20-23MY Range Rover
- 20-23MY RR Sport
- 20-23MY RR Velar

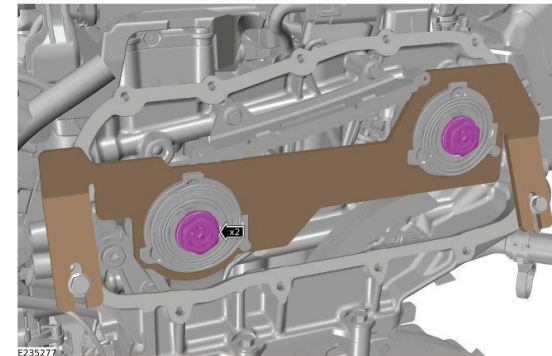

303-01B: Engine - INGENIUM I6 3.0L Petrol, Upper Timing chain