



I N F I N I T I

Nissan Group of the Americas  
Copyright©

# TECHNICAL SERVICE BULLETIN

Classification: AT24-001A	Reference: ITB24-001A	Date: March 22, 2024
------------------------------	--------------------------	-------------------------

## ENGINE SUPPORT TOOLS

This bulletin has been amended. See **AMENDMENT HISTORY** on the last page.  
Please discard previous versions of this bulletin.

**APPLIED VEHICLES:** 2017-2020 QX60 (L50)

### SERVICE INFORMATION

A new Engine Support Tool, Engine Support Bracket, and CVT Transmission Jack Adapter are now available to allow the CVT to be removed from the **APPLIED VEHICLES** without having to remove the engine.

The procedure in this bulletin is different from the procedure currently in the ESM, which will be updated with this information at a later date.

Please refer to the **SERVICE PROCEDURE** in this bulletin for information on how to use these new tools:

- **Front Wheel Drive (FWD)** – pages 4 - 25
- **All Wheel Drive (AWD)** – pages 26 - 52

Bulletins are intended for use by qualified technicians, not 'do-it-yourselfers'. Qualified technicians are properly trained individuals who have the equipment, tools, safety instruction, and know-how to do a job properly and safely. **NOTE:** If you believe that a described condition may apply to a particular vehicle, DO NOT assume that it does. See your Infiniti retailer to determine if this applies to your vehicle.

## SPECIAL TOOLS

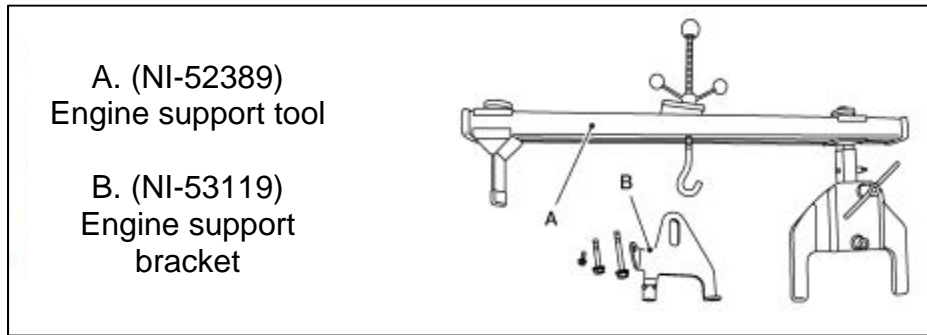

Figure 1

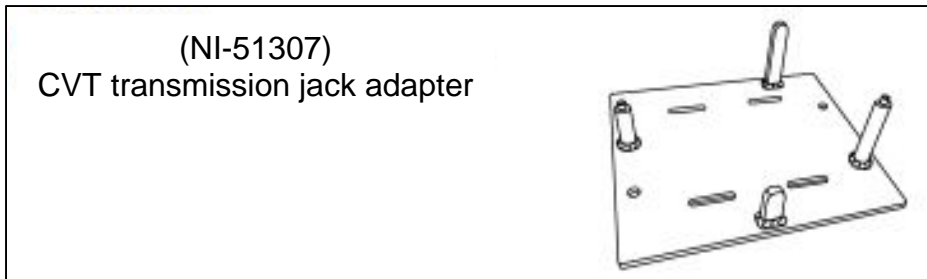

Figure 2



Figure 3



Figure 4

Transmission jack



Figure 5

Drive shaft joint puller



Figure 6

Ball joint remover

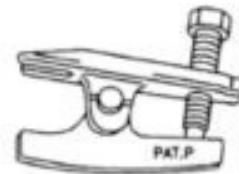

Figure 7

## SERVICE PROCEDURE

### Removal (FWD)

#### **⚠ WARNING**

To avoid the risk of death or severe personal injury, do not remove the radiator cap when the engine is hot. Serious burns could occur from high pressure engine coolant escaping from the radiator. Wrap a thick cloth around the cap. Slowly turn it a quarter turn to allow built-up pressure to escape. Carefully remove the cap by turning it all the way.

#### **⚠ CAUTION**

To avoid the risk of minor personal injury or property damage:

- Perform when the engine is cold.
- When replacing the TCM and transaxle assembly as a set, replace the transaxle assembly first and then replace the TCM. Refer to "Description" in the Transaxle and Transmission section of the ESM.
- When replacing the transaxle assembly, perform "ADDITIONAL SERVICE WHEN REPLACING TRANSAXLE ASSEMBLY." Refer to "Description" in the Transaxle and Transmission section of the ESM.

**HINT:** When removing components such as hoses, tubes/lines, etc., cap or plug openings to prevent fluid from spilling.

1. Remove the battery tray.
  - Refer to "Removal and Installation" in the Power Supply, Ground & Circuit Elements section of the ESM.
2. Remove the cowl top cover and the cowl top extension.
  - Refer to "Removal and Installation" in the Exterior section of the ESM.
3. Remove the engine room cover.
  - Refer to "Removal and Installation" in the Engine Mechanical section of the ESM.

4. Disconnect the harness connector (A) from the transmission range switch (1).

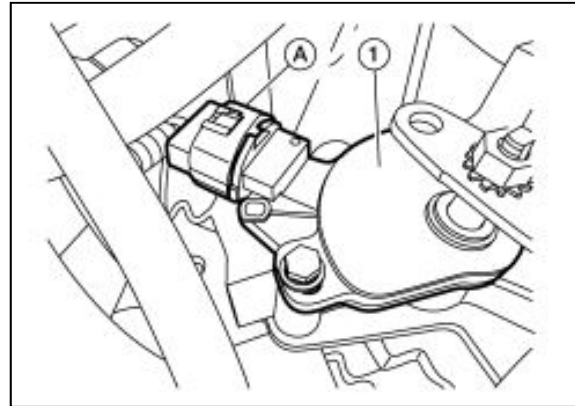

Figure 8

5. Remove the lock plate (1) as shown.

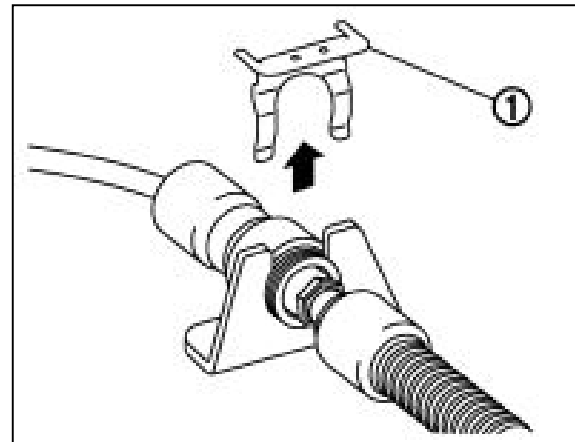

Figure 9

6. Remove nut (A) and separate the control cable (1) from the manual lever (B).

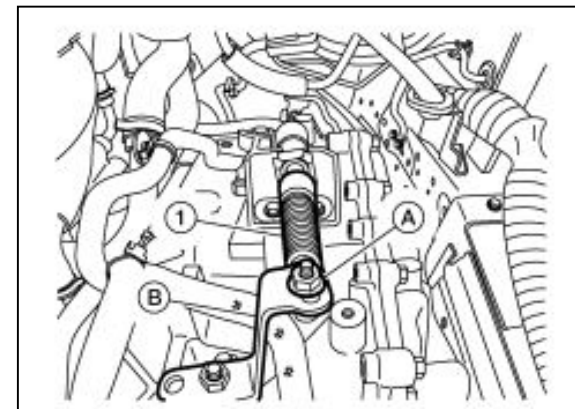

Figure 10

7. Disconnect the brake booster vacuum hose from the intake manifold collector.
  - Refer to the Vacuum Lines "Exploded View" in the Brake System section of the ESM.
8. Disconnect the PCV hose from the intake manifold collector.

9. Remove bolts (A) and set the VIAS Control Solenoid Valves (1) aside.

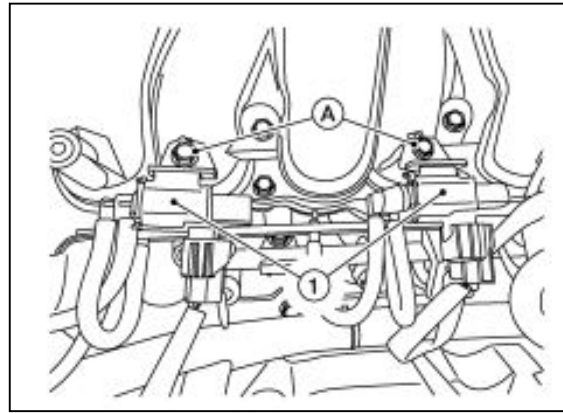

Figure 11

10. Disconnect vacuum hoses (1) from the intake manifold collector (2).

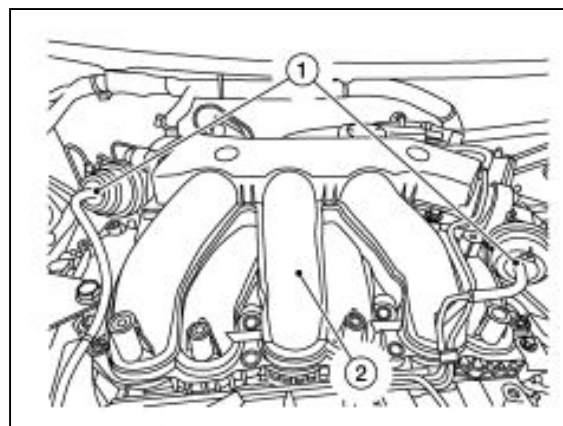

Figure 12

11. Disconnect the vacuum hose (1) from the vacuum pipe (2).

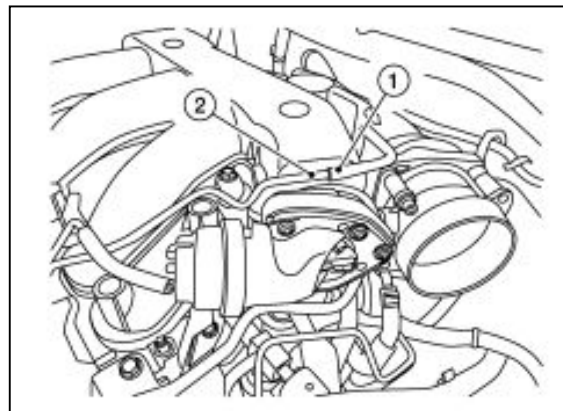

Figure 13

12. Remove clamp (1), and then disconnect hose (2) from pipe (3).
13. Release the pawl, and then remove hose (4) from retainer (A).
14. Remove bolt (B), and then set the EVAP canister purge volume control solenoid (5) aside.
15. Set the vacuum tube assembly (1) aside.

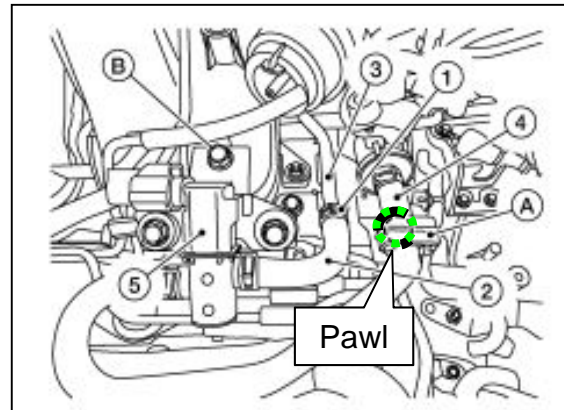

Figure 14

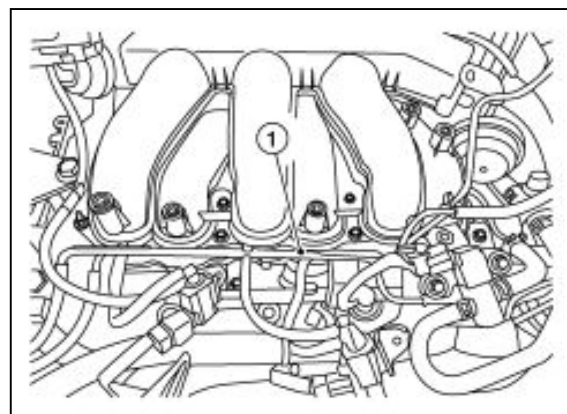

Figure 15

16. Loosen the bolts in reverse of sequence shown (4 to 1), remove the electric throttle control actuator bolts, and then remove the electric throttle control actuator and position aside.

**NOTICE**

To avoid damage to the electric throttle control actuator:

- Handle the electric throttle control actuator carefully to avoid any shock to the electric throttle control actuator.
- Do not disassemble the electric throttle control actuator.

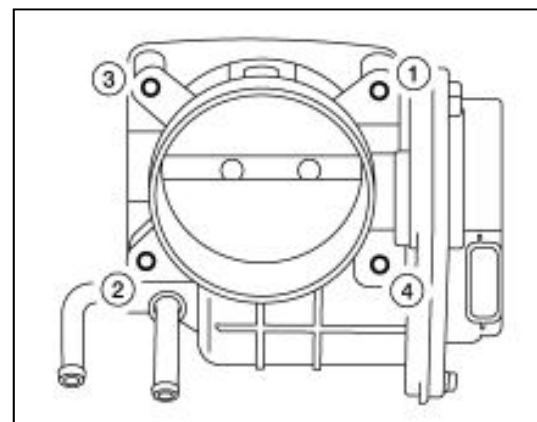

Figure 16

17. Remove bolt (A) and set the bracket (1) aside.

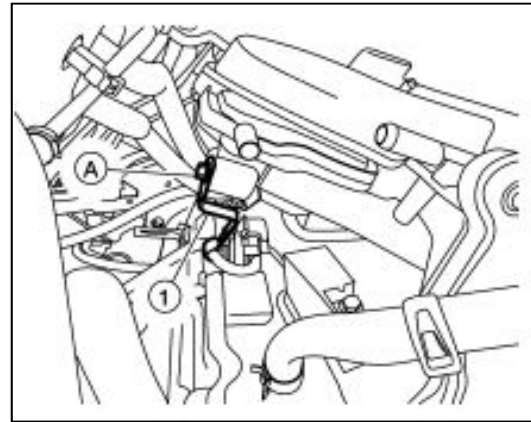

Figure 17

18. Loosen the intake manifold collector bolts and nuts in reverse of sequence shown (6 to 1), and then remove the intake manifold collector and gasket.

**NOTICE**

To avoid the risk of minor property damage, do not reuse the intake manifold collector gasket.

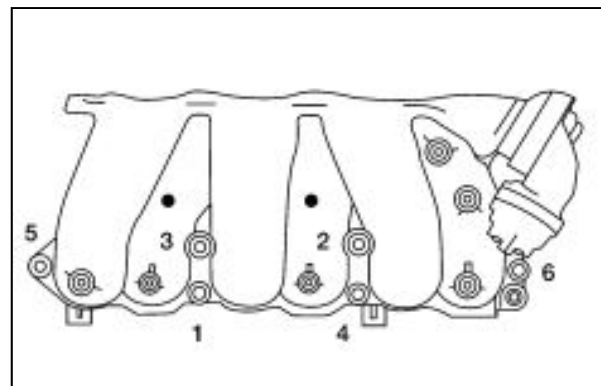

Figure 18

19. Disconnect the transaxle breather hose (1) from the transaxle assembly.

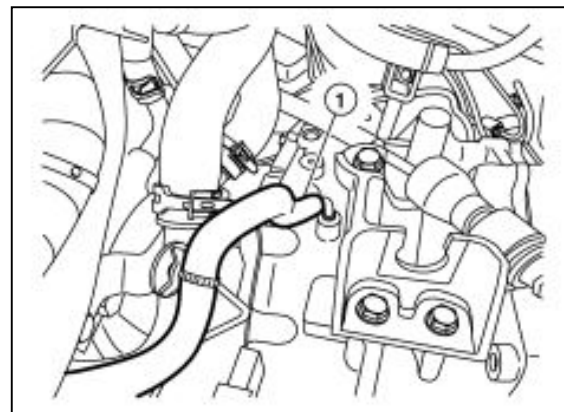

Figure 19



20. Remove bolt (A) from the CVT charge pipe (1).

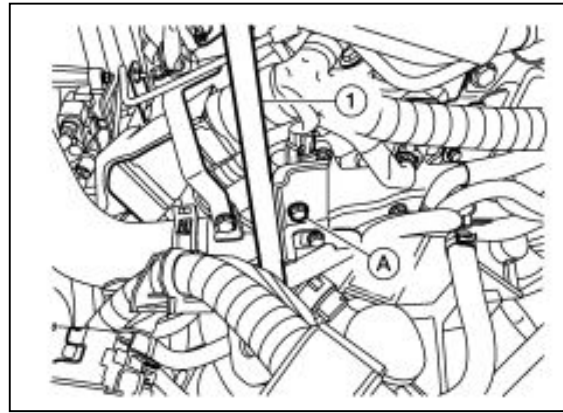

Figure 20

21. Remove bolt (A) from the upper torque rod.

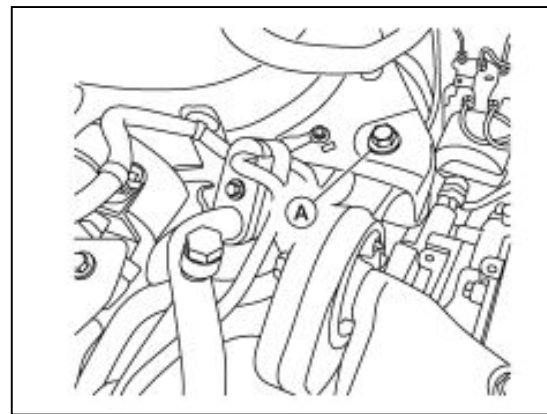

Figure 21

22. Remove the CVT gusset bolt (A).

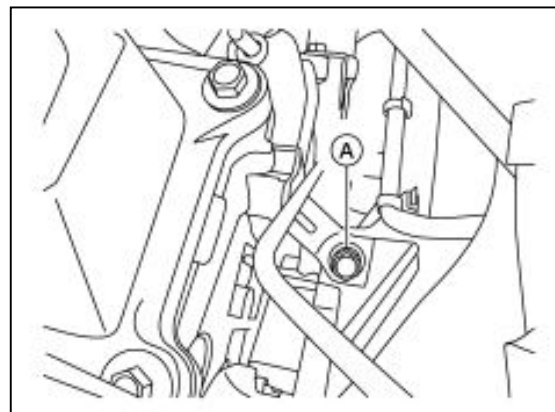

Figure 22

23. Remove bolts (A).

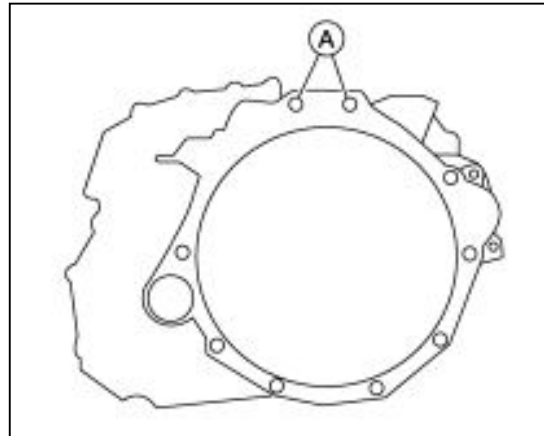

Figure 23

24. Using a suitable tool, release the clip.

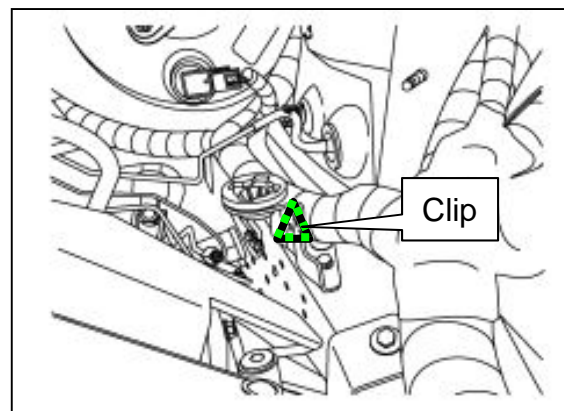

Figure 24

25. Remove the intake stud, and then install Special Tool NI-53119 (A) using bolts (B), (C) and (D) supplied with the tool. Tighten the bolts to specification. Refer to Engine Support Tool Operating Instructions.

- Bolt (B) torque: 24.0 N•m (2.4 kg-m, **18 ft-lb**)
- Bolt (C) torque: 7.0 N•m (0.7 kg-m, **62 in.-lb**)
- Bolt (D) torque: 24.0 N•m (2.4 kg-m, **18 ft-lb**)

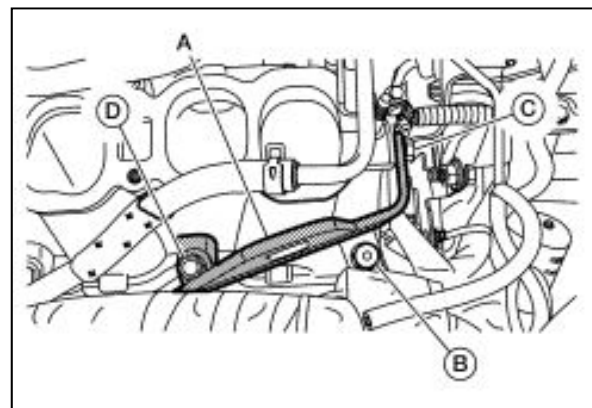

Figure 25

26. Install Special Tool NI-52389 (A) to the driver's (LH) side frame rail (1) as shown. Refer to Engine Support Tool Operating Instructions.

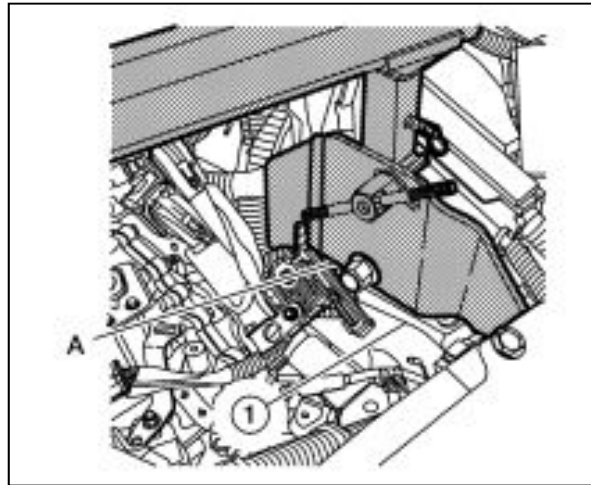

Figure 26

27. Install Special Tool NI-52389 (A) on top of the RH side engine mounting insulator (1) as shown. Refer to Engine Support Tool Operating Instructions.

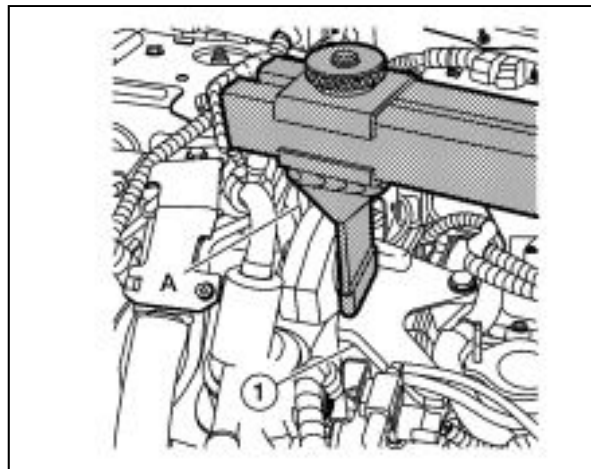

Figure 27

28. Install Special Tool NI-52389 (A) to Special Tool NI-53119 (B). Refer to Engine Support Tool Operating Instructions.

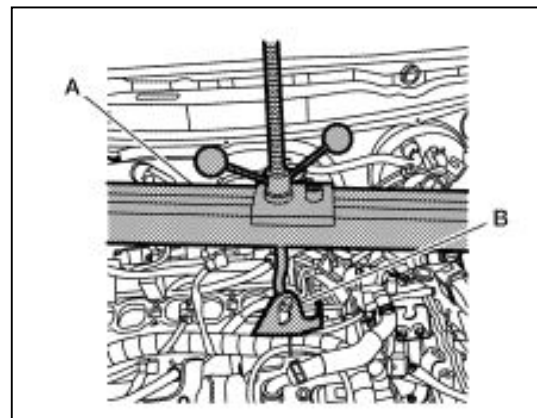

Figure 28

29. Using the bubble level (B) on Special Tool NI-52389 (A), level the tool as shown. Refer to Engine Support Tool Operating Instructions.

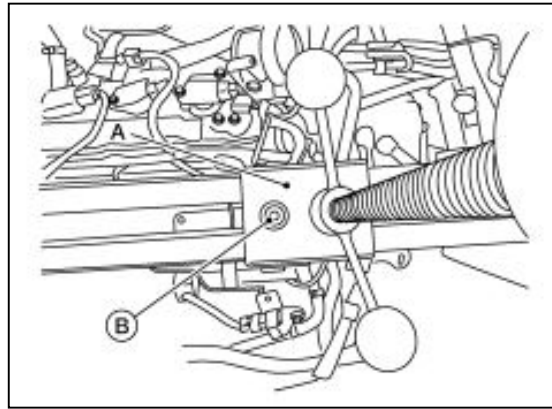

Figure 29

30. Remove the nut from the front engine mounting insulator.
- Refer to the Engine Assembly "Exploded View" in the Engine Mechanical section of the ESM.
31. Remove the nut from the rear engine mounting insulator.
- Refer to the Engine Assembly "Exploded View" in the Engine Mechanical section of the ESM.
32. Remove the front under cover.
- Refer to "Removal and Installation" in the Exterior section of the ESM.
33. Remove the front wheel and tire assemblies.
34. Remove the LH and RH side lock plates (A), and then remove the brake hoses from the struts.

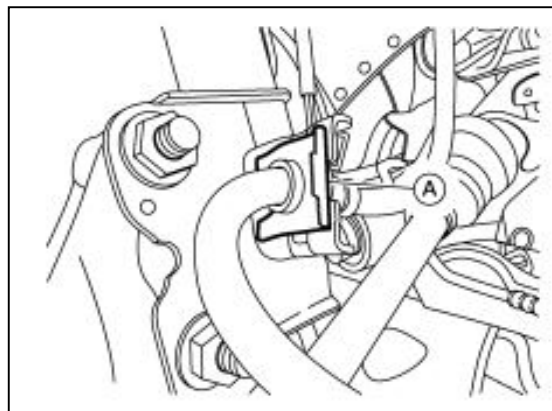

Figure 30

35. Remove the nut and separate the LH and RH side stabilizer connecting rods from the struts.
  - Refer to the Front Stabilizer "Exploded View" in the Front Suspension section of the ESM.
36. Remove the brake caliper torque member bolts, leaving the brake hoses attached, and then position the LH and RH side brake calipers aside with a suitable strap.
  - Refer to the Brake Caliper Assembly "Exploded View" in the Brake System section of the ESM.

**NOTICE**

To avoid damage to the brake calipers, do not depress the brake pedal while the brake calipers are removed.

37. Put alignment marks (A) on the disc brake rotors and on the wheel hubs and bearings, and then remove the LH and RH side disc brake rotors.

**CAUTION**

To avoid the risk of minor personal injury or damage to the brake rotor, do not drop the disc brake rotors.

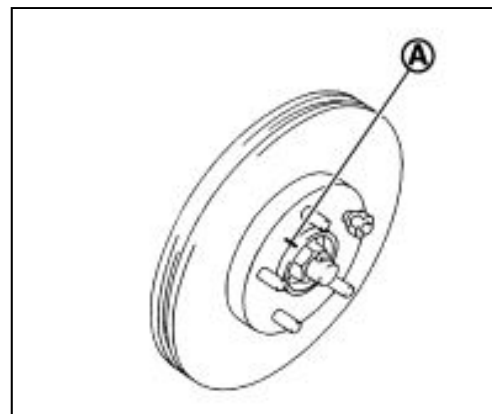

Figure 31

38. Remove the wheel sensor bolts (A), and then position the LH and RH side wheel sensors aside.

**NOTICE**

To avoid damage to the wheel speed sensor, do not pull on the wheel sensor harness.

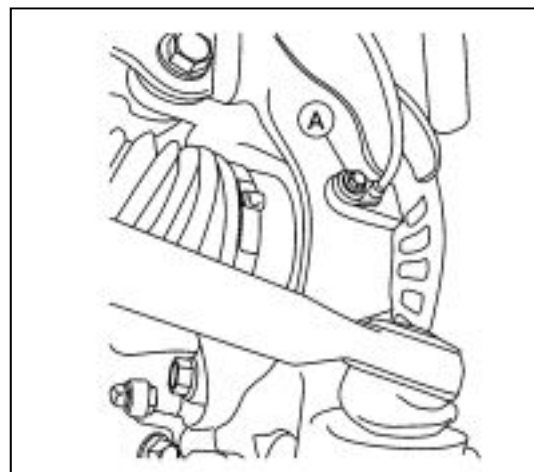

Figure 32

39. Remove the cotter pins from the LH and RH side front drive shafts.
40. Remove the nut retainers from the LH and RH side front drive shafts.
41. Loosen the wheel hub lock nuts from the LH and RH side drive shafts.

42. Using a piece of wood and a suitable tool, tap on the wheel hub lock nuts to disengage the LH and RH side drive shafts from the wheel hub and bearings.

**HINT:** Use a suitable puller if the drive shafts cannot be separated from the wheel hub and bearings.

**NOTICE**

To avoid damage to the drive shaft:

- Do not place the drive shaft joints at an extreme angle.
- Do not over extend the slide joints.
- Do not allow the drive shafts to hang without support.

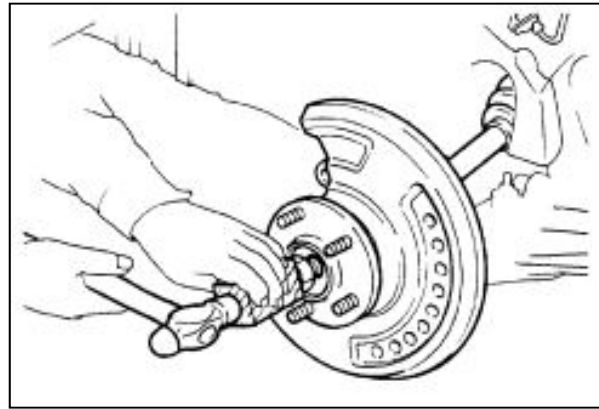

Figure 33

43. Remove the LH and RH side wheel hub lock nuts.

**WARNING**

To avoid the risk of death or severe personal injury, do not reuse the wheel hub lock nuts.

44. Remove the lower strut bolts and nuts, and then separate the LH and RH side steering knuckles from the struts.
- Refer to the Front Coil Spring and Strut "Exploded View" in the Front Suspension section of the ESM.
45. Remove the RH side bearing retainer to support bearing bracket bolts.

46. Insert a Drive Shaft Joint Puller (commercially available) (A) between the drive shafts and transaxle, and then remove the LH and RH side drive shafts from the transaxle.

**NOTICE**

To avoid damage to the drive shaft:

- Confirm that the circular clips are attached to the drive shafts.
- Do not place the drive shaft joints at extreme angles when removing the drive shafts. Also be careful not to overextend the slide joints.
- Do not reuse the circular clips.

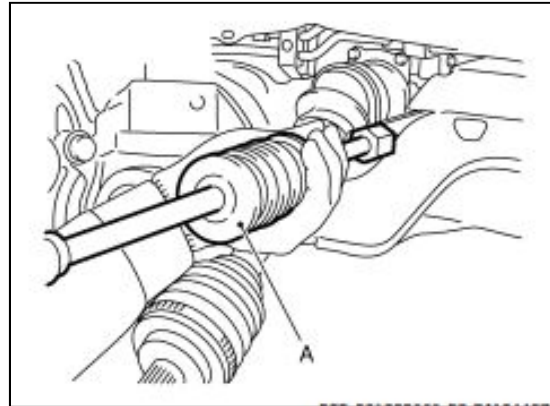

Figure 34

47. Remove the LH and RH side differential side oil seals.

**NOTICE**

To avoid damage to the differential, do not reuse the differential side oil seals.

48. Remove the LH and RH side front fender protector side covers.

- Refer to the Fender Protector "Exploded View" in the Exterior section of the ESM.

49. Remove the front half of the LH and RH side front fender protectors.

- Refer to the Fender Protector "Exploded View" in the Exterior section of the ESM.

50. Remove the LH and RH side outer socket cotter pins.

- Refer to the Steering Gear and Linkage "Exploded View" in the Steering System section of the ESM.

**CAUTION**

To avoid the risk of minor personal injury or property damage, do not reuse the outer socket cotter pins.

51. Loosen the outer socket nuts, and then separate the outer sockets from the LH and RH side steering knuckles using a ball joint remover (commercially available).

**CAUTION**

To avoid the risk of minor personal injury or property damage, leave the outer socket nuts half threaded on the outer sockets to prevent damage to the threads and to prevent the tool from coming off suddenly.

52. Remove bolt (A) and position the crankshaft position sensor (1) aside.

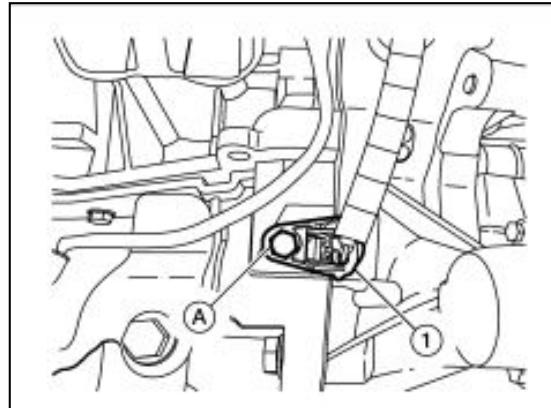

Figure 35

53. Remove the front exhaust tube.
  - Refer to the Exhaust System "Exploded View" in the Exhaust System section of the ESM.

54. Disconnect the front engine mount insulator vacuum hose (1).

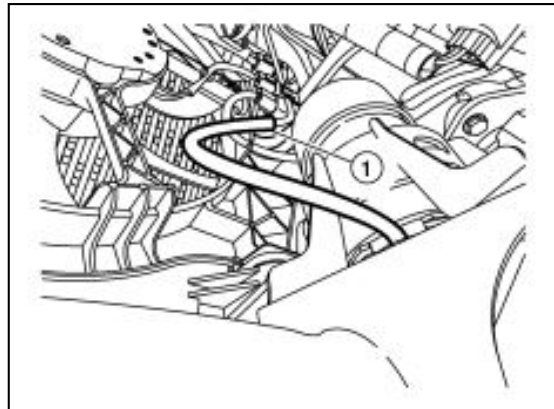

Figure 36



55. Disconnect the rear engine mount insulator vacuum hose (1).

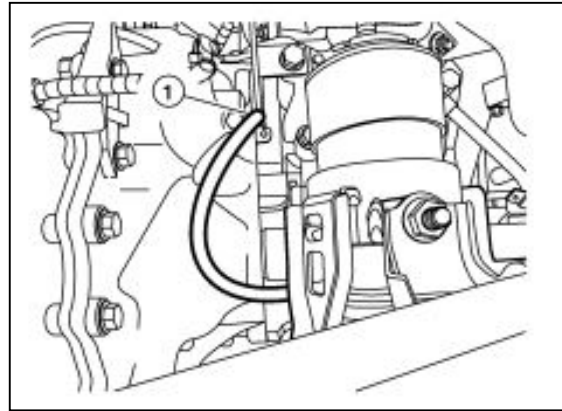

Figure 37

56. Remove bolt (A), and then remove the rear cover plate (1).

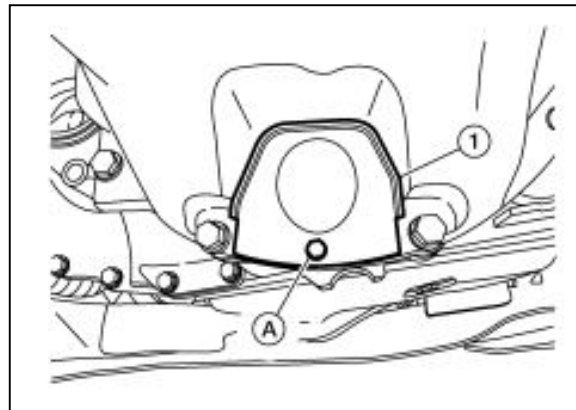

Figure 38

57. Hold the drive plate with a suitable tool, and then remove the torque converter nuts.
- Refer to the Transmission Assembly "Exploded View" in the Transaxle and Transmission section of the ESM.
58. Remove the power steering tube bracket bolts.
- Refer to the Hydraulic Line "Exploded View" in the Steering System section of the ESM.
- HINT:** There are four (4) bolts on the suspension member for the power steering tubes. The power steering tubes will stay with the vehicle during removal and installation.
59. Remove the bolts and nuts from the steering gear.
- Refer to the Steering Gear and Linkage "Exploded View" in the Steering System section of the ESM.
60. Secure the steering gear using a suitable strap.
- HINT:** The steering gear will remain in the vehicle during removal and installation.

61. Remove bolts (A) from the transaxle mount.

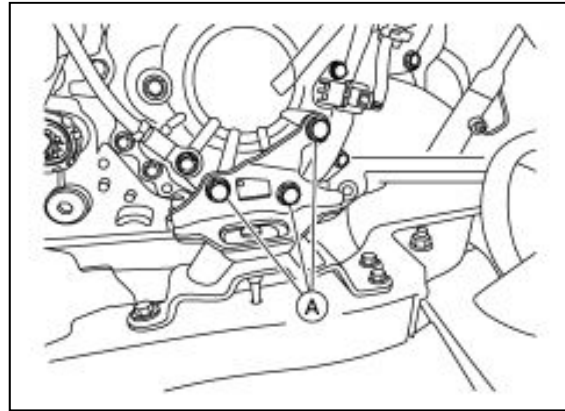

Figure 39

62. Remove bolt (A) and position the ground (1) aside.

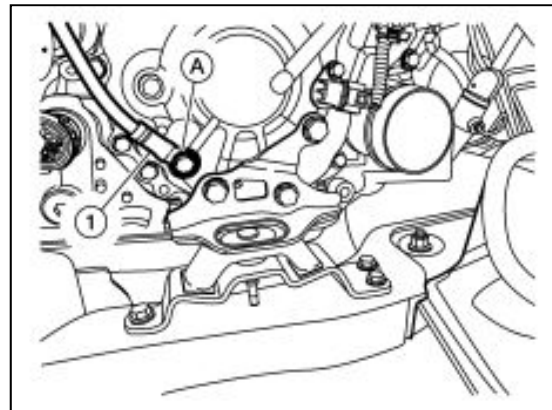

Figure 40

63. Remove the rear torque rod bolt.

- Refer to the Engine Assembly "Exploded View" in the Engine Mechanical section of the ESM.

64. Set the hydraulic lift table (A) or equivalent tool under the front suspension member.

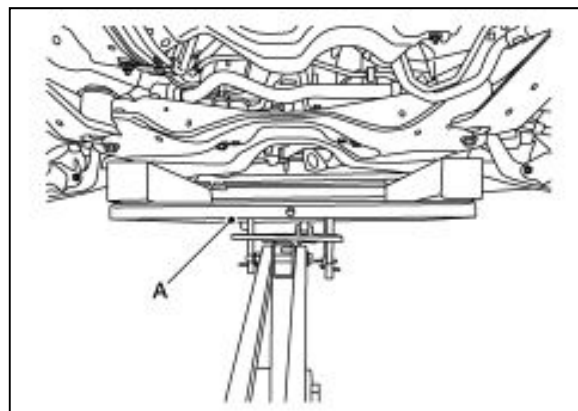

Figure 41

65. Remove the front suspension member bolts and the front suspension member stays.
- Refer to the Front Suspension Member "Exploded View" in the Front Suspension section of the ESM.

**⚠CAUTION**

To avoid the risk of minor personal injury or property damage, secure the front suspension member to the hydraulic lift table (or equivalent tool) while removing it.

66. Lower the front suspension member.

67. Remove the bolt from the heater thermostat bracket.

- Refer to the Water Hose "Exploded View" in the Transmission and Transaxle section of the ESM.

68. Drain the coolant.

- Refer to "Changing Engine Coolant" in the Engine Cooling System section of the ESM.

69. Remove CVT fluid cooler hose "A" and CVT fluid cooler hose "D" from the CVT oil warmer.

- Refer to the CVT Fluid Cooler System "Exploded View" in the Transaxle and Transmission section of the ESM.

70. Remove CVT water hose "A" and CVT water hose "B" from the CVT oil warmer.

- Refer to the Water Hose "Exploded View" in the Transaxle and Transmission section of the ESM.

71. Using the Special Tools NI-52389 and NI-53119, lower the engine and transaxle assembly until the transaxle assembly is low enough to clear the driver's (LH) side frame rail.

72. Disconnect the harness connector from the starter motor "S" terminal.

- Refer to the Starter Motor "Exploded View" in the Starting System section of the ESM.

73. Remove the nut, and then remove "B" terminal harness and position aside.

- Refer to the Starter Motor "Exploded View" in the Starting System section of the ESM.

74. Remove the starter motor bolts, and then remove the starter motor.
- Refer to the Starter Motor "Exploded View" in the Starting System section of the ESM.

75. Remove bolt (A), and then remove the CVT fluid charging pipe (1).

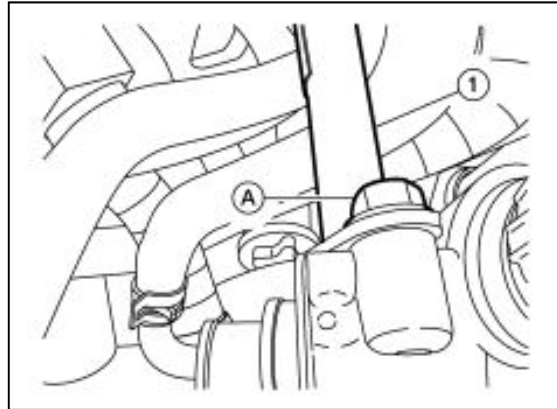

Figure 42

76. Separate the harness retainers from the transaxle assembly.

77. Disconnect the harness connector (A) from the transaxle assembly.

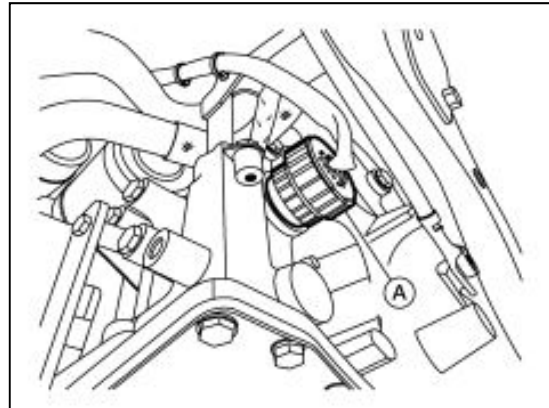

Figure 43

78. Disconnect the harness connector from the output speed sensor.
- Refer to the Output Speed Sensor "Exploded View" in the Transaxle and Transmission section of the ESM.
79. Disconnect the harness connector from the primary speed sensor.
- Refer to the Primary Speed Sensor "Exploded View" in the Transaxle and Transmission section of the ESM.

80. Disconnect the harness connector from the input speed sensor.
- Refer to the Input Speed Sensor "Exploded View" in the Transaxle and Transmission section of the ESM.

81. Using Special Tool NI-51307, support the transaxle assembly.

**⚠CAUTION**

To avoid the risk of minor personal injury or property damage:

- Always secure the transaxle assembly to the transmission jack.
- Do not lift or support the transaxle assembly using the bottom of the oil pan or damage can occur.

82. Remove bolts (A), (B), (C), and (D).

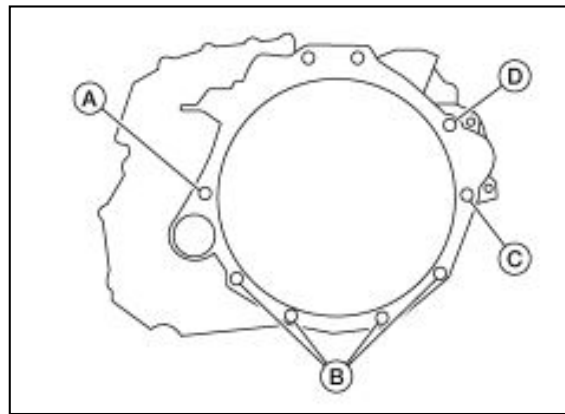

Figure 44

83. Separate the transaxle assembly from the engine assembly, and then lower the transaxle assembly.

**⚠CAUTION**

To avoid the risk of minor personal injury or property damage, secure the torque converter to the transaxle while removing the transaxle to prevent the torque converter from falling.

## Installation (FWD)

84. Installation is in the reverse order of removal. Refer to **Inspection Before Installation (FWD)** below.
- If the same transaxle assembly will be reinstalled, replace the LH and RH side differential side oil seals.
    - Refer to the Differential Side Oil Seal "Exploded View" in the Transaxle and Transmission section of the ESM.
  - If a new transaxle assembly is being installed, write down the serial number of the new transaxle assembly.

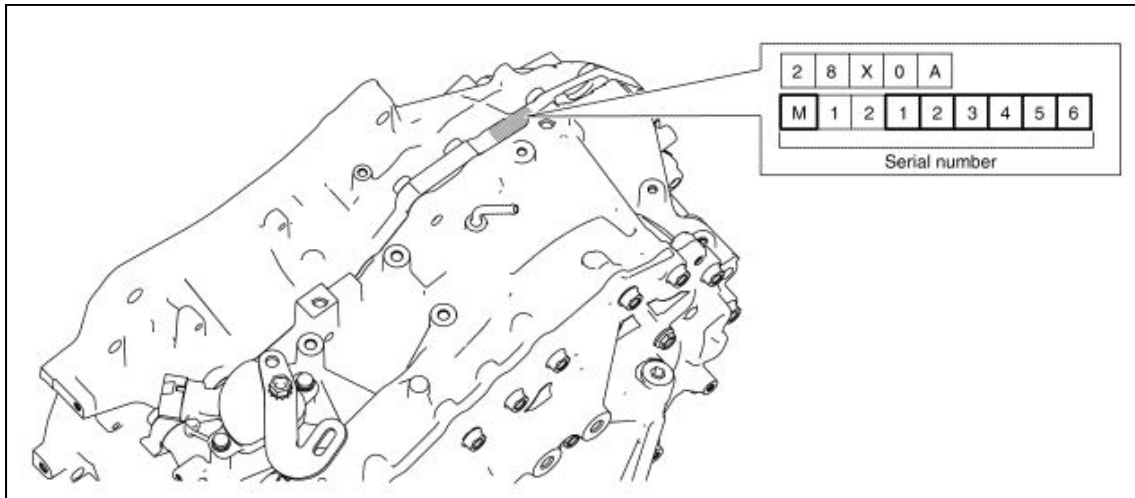

Figure 45

### **CAUTION**

To avoid the risk of minor personal injury or property damage:

- When replacing an engine or transaxle you must make sure any dowels are installed correctly during re-assembly.
- Improper alignment caused by missing dowels may cause vibration, oil leaks, or breakage of drivetrain components.
- Do not reuse O-rings or copper sealing washers.
- When turning crankshaft, turn it clockwise as viewed from the front of the engine.
- When tightening the nuts for the torque converter while securing the crankshaft pulley bolt, be sure to confirm the tightening torque of the crankshaft pulley bolt.
  - Refer to the Front Timing Chain Case "Removal and Installation" in the Engine Mechanical section of the ESM.
- After the torque converter is installed to the drive plate, rotate crankshaft several turns to check that the CVT rotates freely without binding.
- When installing the CVT to the engine, align the matching mark on the drive plate with the matching mark on the torque converter.
- Do not reuse differential side oil seals.

**HINT:**

- When installing the drive plate to torque converter nuts, tighten them temporarily, and then tighten the nuts to the specified torque.
  - Refer to the "Exploded View" in the Transaxle and Transmission section of the ESM.
- Install the transaxle assembly and engine assembly mounting bolts according to the following standards:

Bolt No.	1		2		3		4		5
Number of bolts	1		2		1		1		4
Bolt length "ℓ" mm (in)	52 (2.05)	47 (1.85)	36 (1.42)	47 (1.85)	29 (1.14)	47 (1.85)	44 (1.73)	47 (1.85)	39.8 (1.57)
Tightening torque N·m (kg-m, ft-lb)	74.5 (7.6, 55)	62 (6.3, 46)	74.5 (7.6, 55)	62 (6.3, 46)	74.5 (7.6, 55)	62 (6.3, 46)	74.5 (7.6, 55)	62 (6.3, 46)	50.0 (5.1, 37)

Figure 46

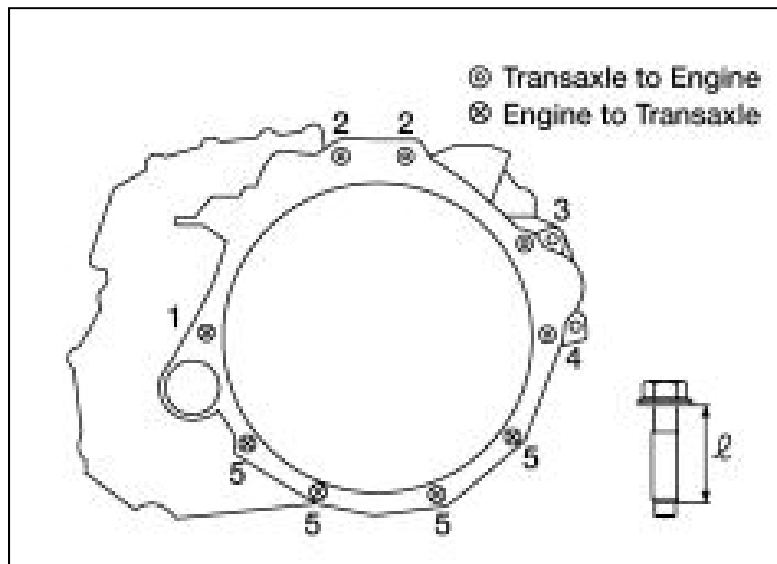

Figure 47

## Inspection Before Installation (FWD)

85. After inserting the torque converter into the CVT, check that dimension (A) is within the reference value limit.
- **Dimension A:** Refer to "Service Data and Specifications (SDS)" in the Transaxle and Transmission section of the ESM.
  - **B:** Scale
  - **C:** Straightedge

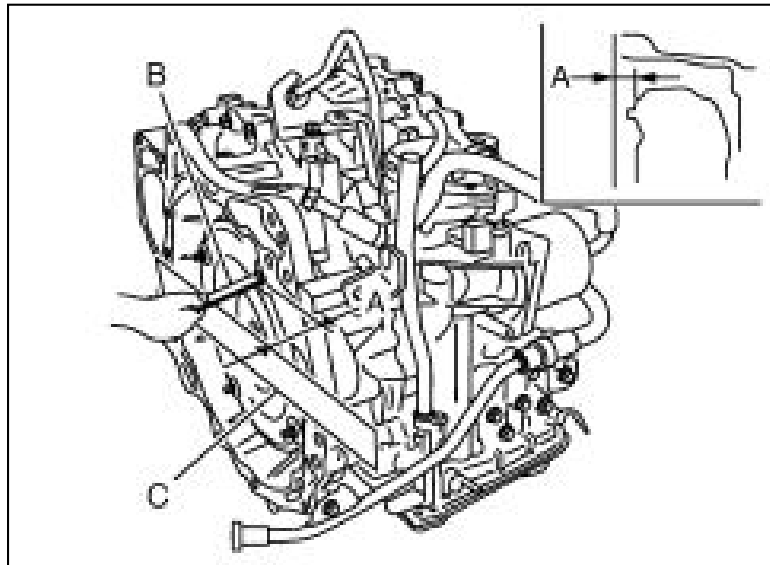

Figure 48



## **Adjustment After Installation (FWD)**

86. Perform the following:

- Adjust the CVT position.
  - Refer to "Adjustment" in the Transaxle and Transmission section of the ESM.
- Check and adjust the engine coolant level.
  - Refer to "Changing Engine Coolant" in the Engine Cooling System section of the ESM.
- Adjust the CVT fluid level.
  - Refer to "Adjustment" in the Transaxle and Transmission section of the ESM.
- Perform the accelerator pedal released position learning.
  - Refer to "Description" in the Engine Control section of the ESM.
- Perform the throttle valve closed position learning.
  - Refer to "Description" in the Engine Control section of the ESM.
- Perform a front wheel alignment.
  - Refer to "Wheel Alignment" in the Front Suspension section of the ESM.
- Perform adjustment of the steering angle sensor neutral position.
  - Refer to "Description" in the Brake Control System section of the ESM.

## **Inspection After Installation (FWD)**

87. Inspect the following items:

- Inspect for CVT fluid leakage.
  - Refer to "Inspection" in the Transaxle and Transmission section of the ESM.
- Inspect the CVT shifter position.
  - Refer to "Inspection" in the Transaxle and Transmission section of the ESM.
- Start the engine and inspect for coolant leaks.

## Removal (AWD)

### **⚠ WARNING**

To avoid the risk of death or severe personal injury, do not remove the radiator cap when the engine is hot. Serious burns could occur from high pressure engine coolant escaping from the radiator. Wrap a thick cloth around the cap. Slowly turn it a quarter turn to allow built-up pressure to escape. Carefully remove the cap by turning it all the way.

### **⚠ CAUTION**

To avoid the risk of minor personal injury or property damage:

- Perform when the engine is cold.
- When replacing the TCM and transaxle assembly as a set, replace the transaxle assembly first and then replace the TCM.
  - Refer to "Description" in the Transaxle and Transmission section of the ESM.
- When replacing the transaxle assembly, perform "ADDITIONAL SERVICE WHEN REPLACING TRANSAXLE ASSEMBLY."
  - Refer to "Description" in the Transaxle and Transmission section of the ESM.

**HINT:** When removing components such as hoses, tubes/lines, etc., cap or plug openings to prevent fluid from spilling.

1. Remove the battery tray.
  - Refer to "Removal and Installation" in the Power Supply, Ground & Circuit Elements section of the ESM.
2. Remove the cowl top cover and the cowl top extension.
  - Refer to "Removal and Installation" in the Exterior section of the ESM.
3. Remove the engine room cover.
  - Refer to "Removal and Installation" in the Engine Mechanical section of the ESM.

4. Disconnect the harness connector (A) from the transmission range switch (1).

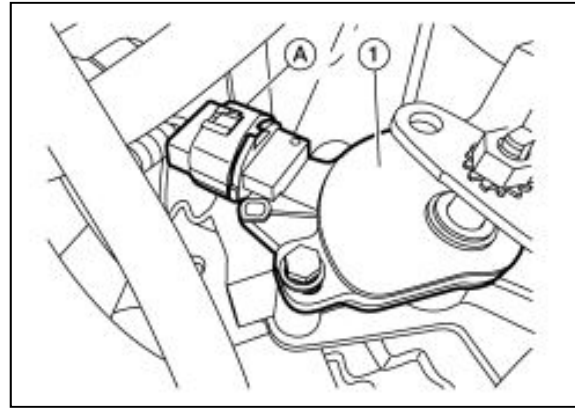

Figure 49

5. Remove the lock plate (1) as shown.

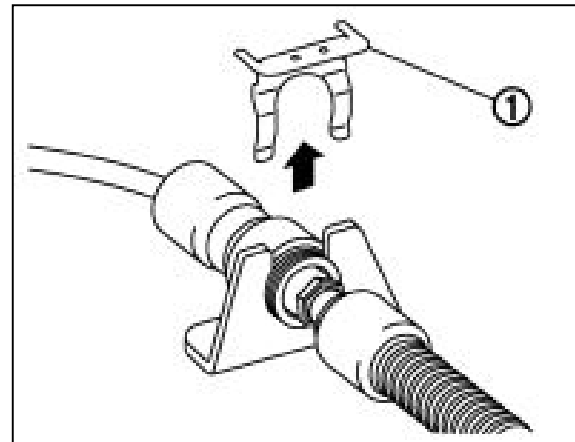

Figure 50

6. Remove nut (A) and separate the control cable (1) from the manual lever (B).

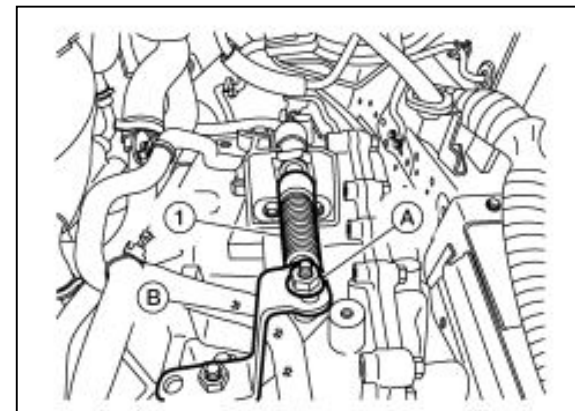

Figure 51

7. Disconnect the brake booster vacuum hose from the intake manifold collector.
  - Refer to the Vacuum Lines "Exploded View" in the Brake System section of the ESM.
8. Disconnect the PCV hose from the intake manifold collector.

9. Remove bolts (A) and set the VIAS Control Solenoid Valves (1) aside.

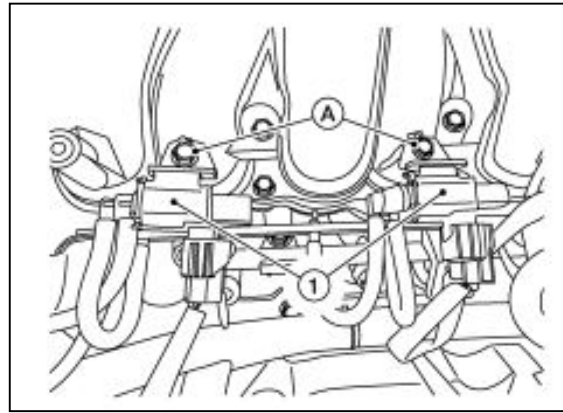

Figure 52

10. Disconnect vacuum hoses (1) from the Intake Manifold Collector (2).

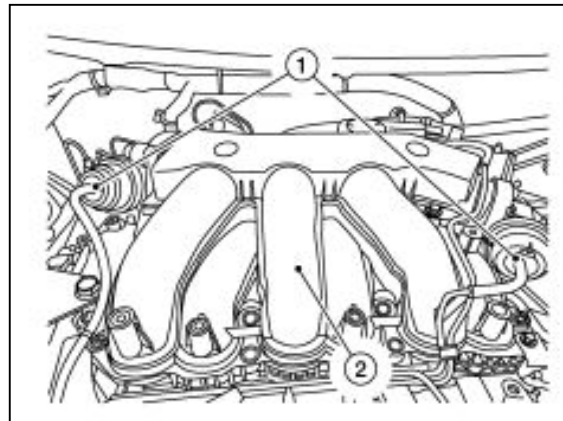

Figure 53

11. Disconnect the vacuum hose (1) from the vacuum pipe (2).

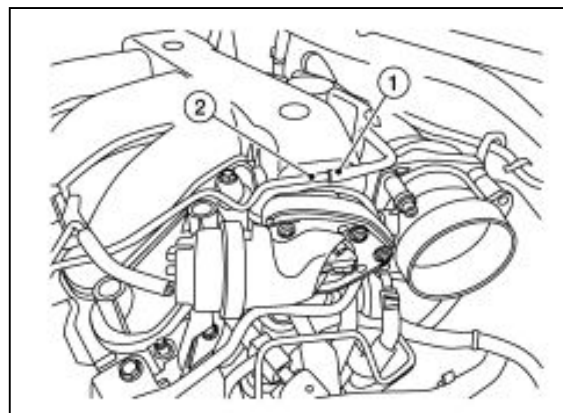

Figure 54

12. Remove clamp (1), and then disconnect hose (2) from pipe (3).
13. Release the pawl, and then remove hose (4) from retainer (A).
14. Remove bolt (B), and then set the EVAP canister purge volume control solenoid (5) aside.
15. Set vacuum tube assembly (1) aside.

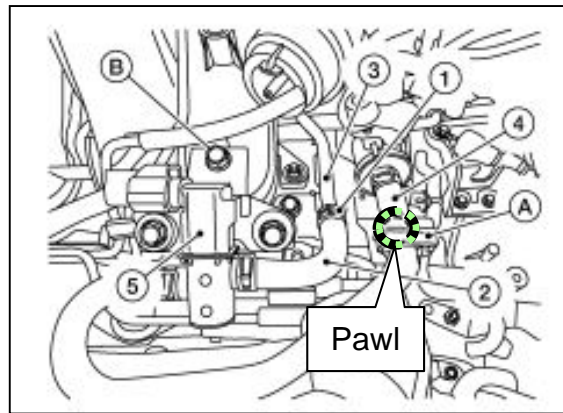

Figure 55

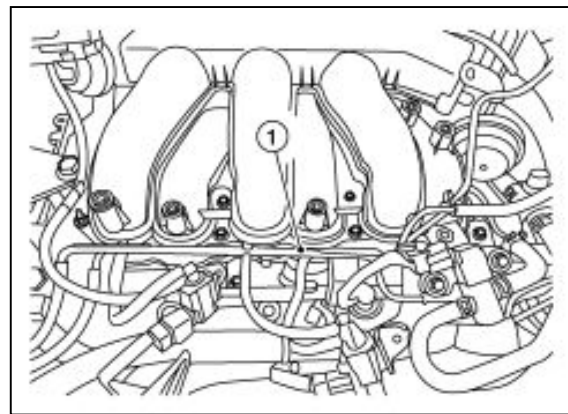

Figure 56

16. Loosen the four (4) bolts in reverse of sequence shown, remove the electric throttle control actuator bolts, and then remove the electric throttle control actuator and position aside.

**NOTICE**

To avoid damage to the electric throttle control actuator:

- Handle the electric throttle control actuator carefully to avoid any shock to the electric throttle control actuator.
- Do not disassemble the electric throttle control actuator.

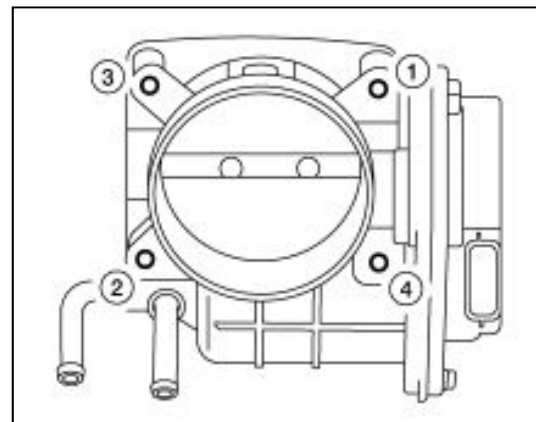

Figure 57

17. Remove bolt (A) and set the bracket (1) aside.

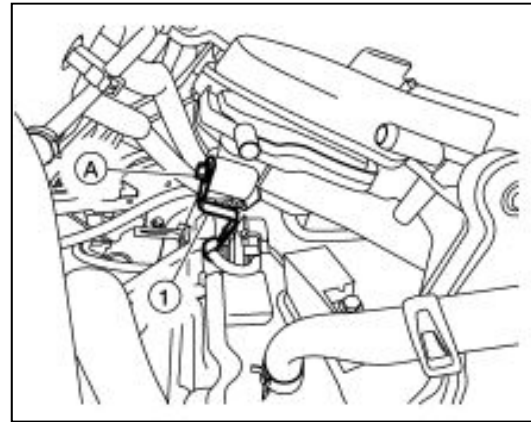

Figure 58

18. Loosen the intake manifold collector bolts and nuts in reverse of sequence shown, and then remove the intake manifold collector and gasket.

**NOTICE**

To avoid damage to the intake manifold, do not reuse the intake manifold collector gasket.

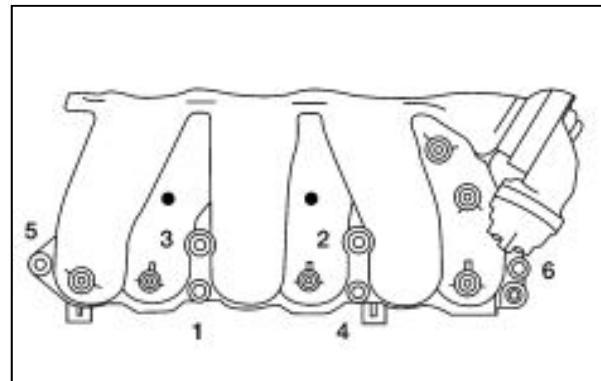

Figure 59

19. Disconnect the transaxle breather hose (1) from the transaxle assembly.

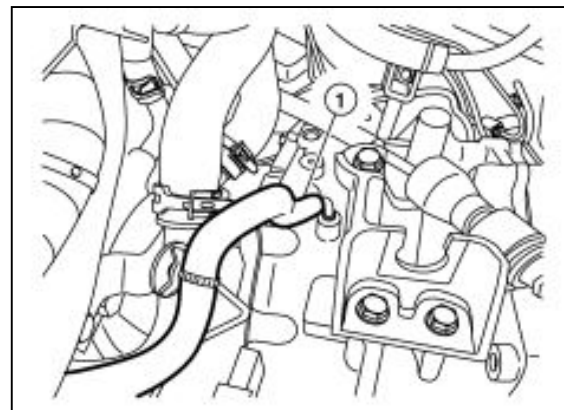

Figure 60

20. Remove bolt (A) from the CVT charge pipe (1).

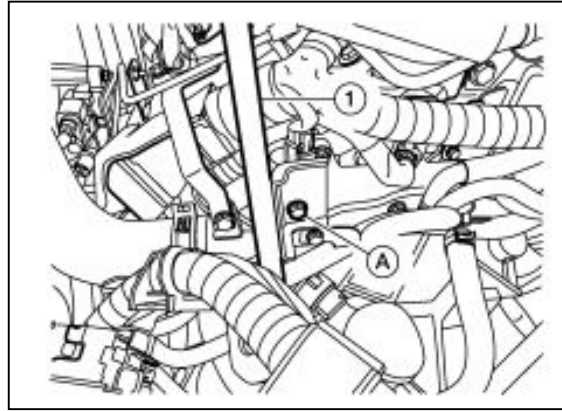

Figure 61

21. Remove bolt (A) from the upper torque rod.

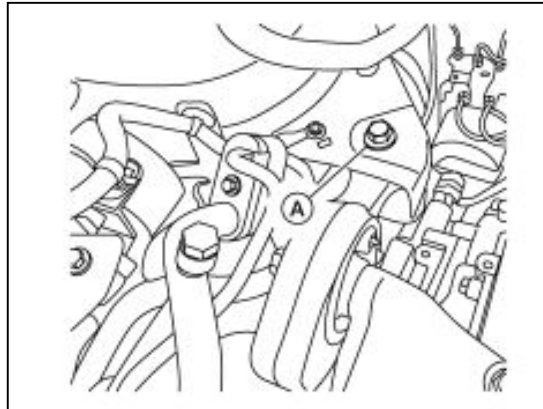

Figure 62

22. Remove the CVT gusset bolt (A).

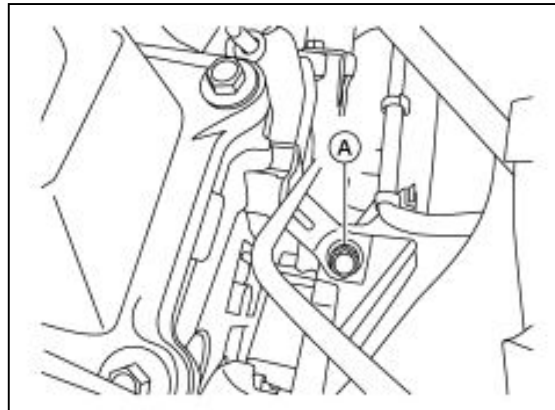

Figure 63

23. Remove bolts (A).

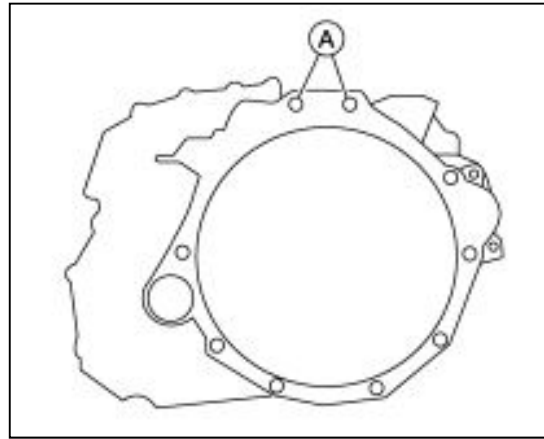

Figure 64

24. Using a suitable tool, release the clip.

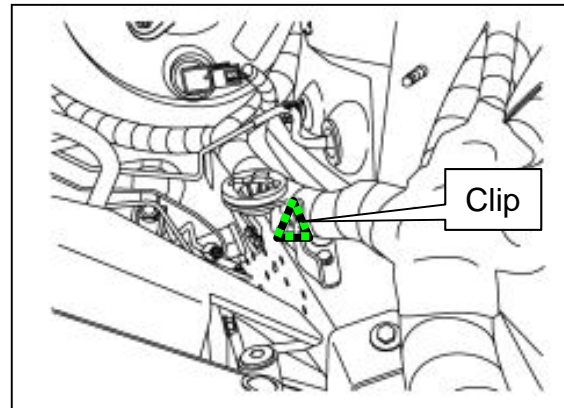

Figure 65

25. Remove the intake stud and install Special Tool NI-53119 (A) using bolts (B), (C) and (D) supplied with the tool. Tighten the bolts to the specification shown below. Refer to Engine Support Tool Operating Instructions.

- Bolt (B) torque: 24.0 N•m (2.4 kg-m, **18 ft-lb**)
- Bolt (C) torque: 7.0 N•m (0.7 kg-m, **62 in.-lb**)
- Bolt (D) torque: 24.0 N•m (2.4 kg-m, **18 ft-lb**)

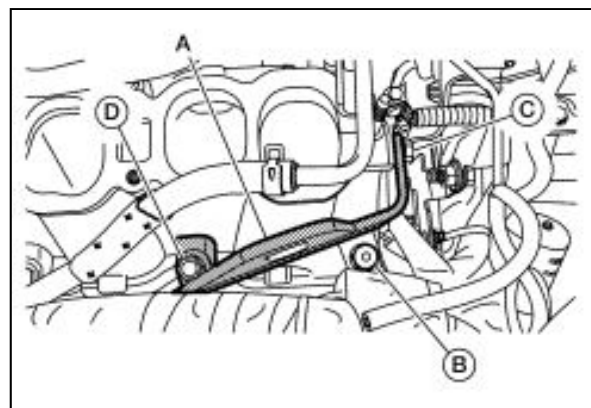

Figure 66



26. Install Special Tool NI-52389 (A) to the driver's (LH) side frame rail (1) as shown. Refer to Engine Support Tool Operating Instructions.

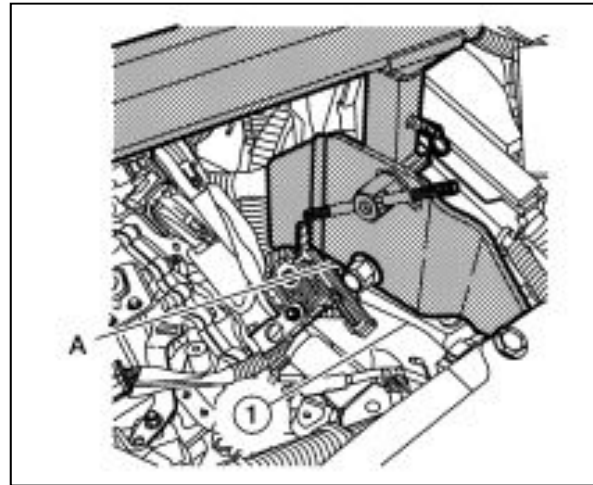

Figure 67

27. Install Special Tool NI-52389 (A) on top of the RH side engine mounting insulator (1) as shown. Refer to Engine Support Tool Operating Instructions.

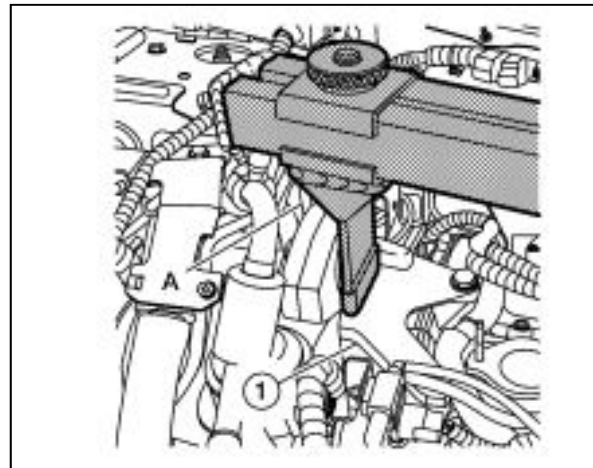

Figure 68

28. Install Special Tool NI-52389 (A) to Special Tool NI-53119 (B). Refer to Engine Support Tool Operating Instructions.

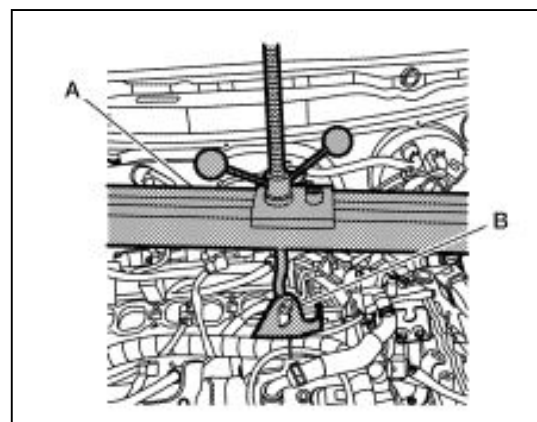

Figure 69

29. Using a bubble level (B) on Special Tool NI-52389 (A), level the tool as shown. Refer to Engine Support Tool Operating Instructions.

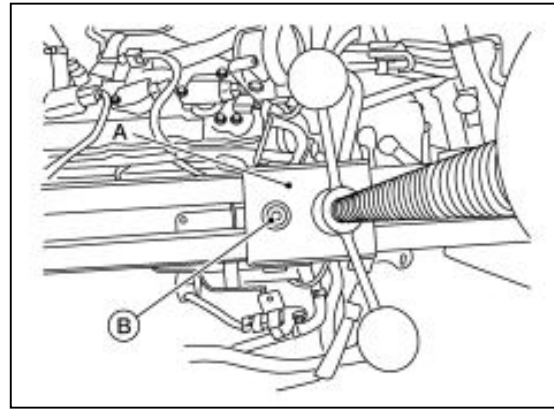

Figure 70

30. Remove the nut from the engine mounting insulator (front).
- Refer to the Engine Assembly "Exploded View" in the Engine Mechanical section of the ESM.
31. Remove the nut from the engine mounting insulator (rear).
- Refer to the Engine Assembly "Exploded View" in the Engine Mechanical section of the ESM.
32. Remove the front under cover.
- Refer to "Removal and Installation" in the Exterior section of the ESM.
33. Remove the front wheel and tire assemblies.
34. Remove the LH and RH side lock plates (A), and then remove the brake hoses from the struts.

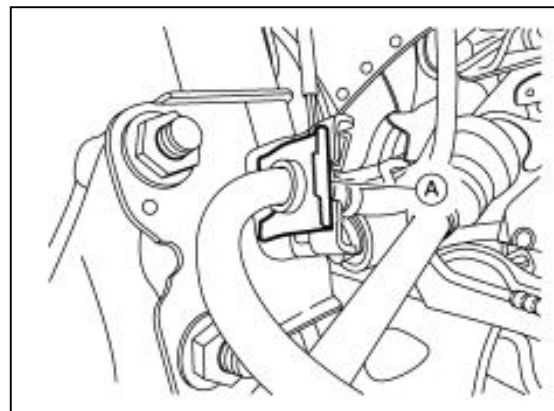

Figure 71

35. Remove the nut, and then separate the LH and RH side stabilizer connecting rods from the struts.
  - Refer to the Front Stabilizer "Exploded View" in the Front Suspension section of the ESM.
36. Remove the brake caliper torque member bolts, leaving the brake hoses attached, and then position the LH and RH side brake calipers aside with a suitable strap.
  - Refer to the Brake Caliper Assembly "Exploded View" in the Brake System section of the ESM.

**NOTICE**

To avoid damage to the brake caliper, do not depress the brake pedal while the brake calipers are removed.

37. Put alignment marks (A) on the disc brake rotors and the wheel hub and bearings, and then remove the LH and RH side disc brake rotors.

**CAUTION**

To avoid the risk of minor personal injury or property damage, do not drop the disc brake rotors.

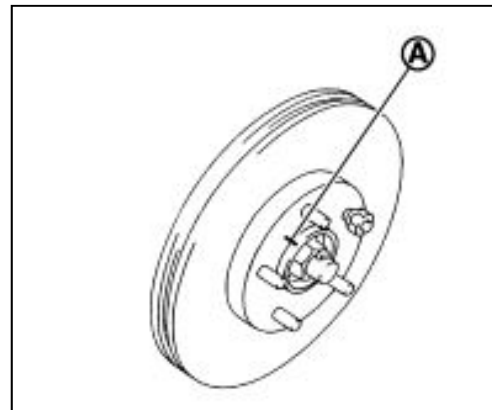

Figure 72

38. Remove the wheel sensor bolts (A), and then position the LH and RH side wheel sensors aside.

**NOTICE**

To avoid damage to the wheel speed sensor, do not pull on the wheel sensor harness.

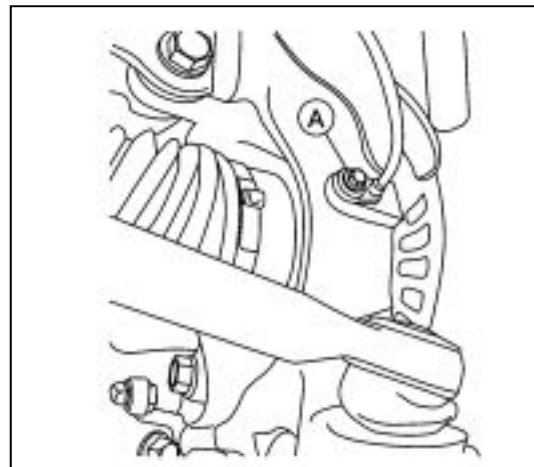

Figure 73

39. Remove the cotter pins from the LH and RH side front drive shafts.
40. Remove the nut retainers from the LH and RH side front drive shafts.
41. Loosen the wheel hub lock nuts from the LH and RH side drive shafts.

42. Using a piece of wood and a suitable tool, tap on the wheel hub lock nuts to disengage the drive shafts from the wheel hub and bearings (LH/RH).

**HINT:** Use a suitable puller if the drive shafts cannot be separated from the wheel hub and bearings.

**NOTICE**

To avoid damage to the drive shaft:

- Do not place drive shaft joints at an extreme angle.
- Do not over extend slide joints.
- Do not allow drive shafts to hang without support.

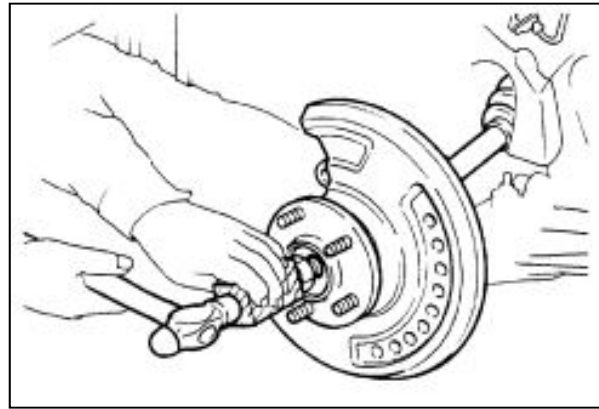

Figure 74

43. Remove the LH and RH side wheel hub lock nuts.

**WARNING**

To avoid the risk of death or severe personal injury, do not reuse the wheel hub lock nuts.

44. Remove the lower strut bolts and nuts, and then separate the LH and RH side steering knuckles from the struts.
- Refer to the Front Coil Spring and Strut "Exploded View" in the Front Suspension section of the ESM.
45. Remove the RH side bearing retainer to support bearing bracket bolts.

46. Insert a Drive Shaft Joint Puller (commercially available) (A) between the drive shafts and the transaxle, and then remove the LH and RH side drive shafts from the transaxle.

**NOTICE**

To avoid damage to the drive shaft:

- Confirm that the circular clips are attached to the drive shafts.
- Do not place drive shaft joints at extreme angles when removing drive shafts. Also be careful not to overextend slide joints.
- Do not reuse the circular clips.

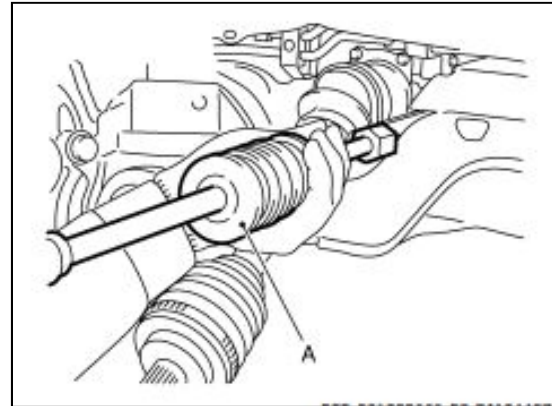

Figure 75

47. Remove the differential side oil seal.

**NOTICE**

To avoid damage to the differential, do not reuse the differential side oil seal.

48. Remove the transfer case oil seal.

**NOTICE**

To avoid damage to the transfer case, do not reuse the transfer case oil seal.

49. Remove the LH and RH side front fender protector side covers.

- Refer to the Fender Protector "Exploded View" in the Exterior section of the ESM.

50. Remove the LH and RH side front half of the front fender protectors.

- Refer to the Fender Protector "Exploded View" in the Exterior section of the ESM.

51. Remove bolt (A), and then position the crankshaft position sensor (1) aside.

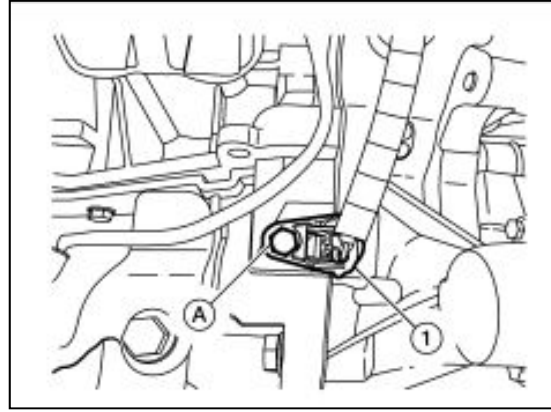

Figure 76

52. Remove the front exhaust tube.
- Refer to the Exhaust System "Exploded View" in the Exhaust System section of the ESM.

53. Disconnect the front engine mount insulator vacuum hose (1).

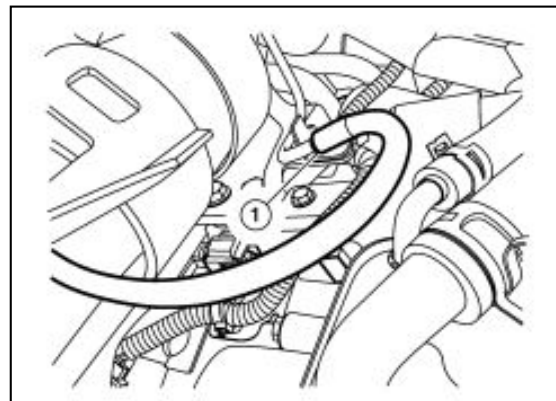

Figure 77

54. Remove bolt (A) from the engine mounting insulator (front) pipe bracket.

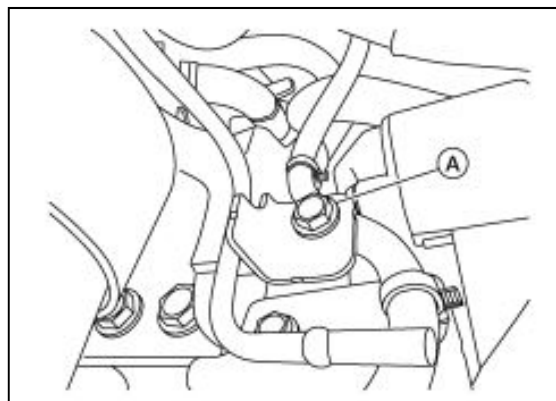

Figure 78

55. Remove bolt (A), and then set bracket (1) aside.

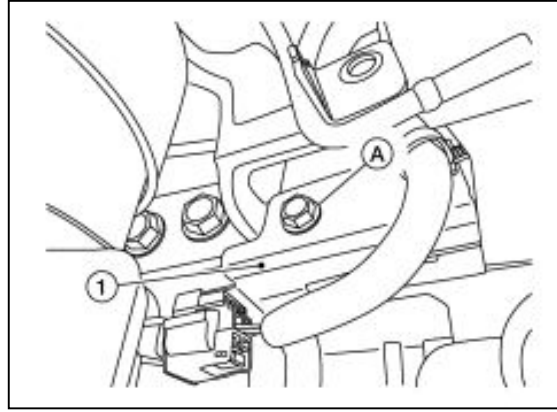

Figure 79

56. Remove bolt (A), and then remove the rear cover plate (1).

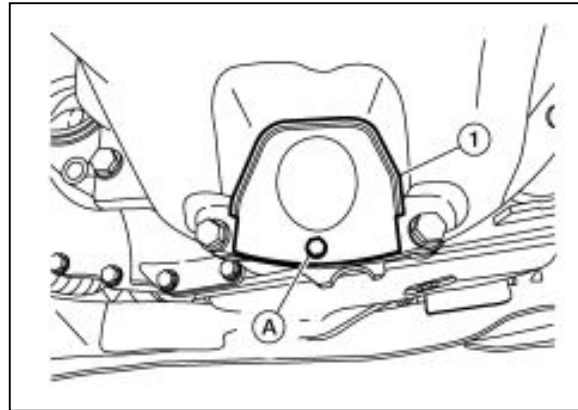

Figure 80

57. Hold the drive plate with a suitable tool, and then remove the torque converter nuts.
- Refer to the Transmission Assembly "Exploded View" in the Transaxle and Transmission section of the ESM.

58. Using a suitable tool, release the clip.

59. Release hose clamp (1), and then separate the lower high pressure piping (2) from the upper low pressure piping (3).

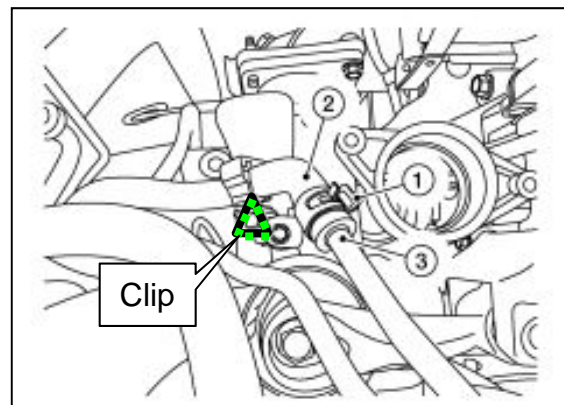

Figure 81

60. Remove the power steering tube bracket bolts.
- Refer to the Hydraulic Line "Exploded View" in the Steering System section of the ESM.

**HINT:** There are three (3) bolts on the suspension member for the power steering tubes.

61. Using a suitable tool, release the retainer (A).

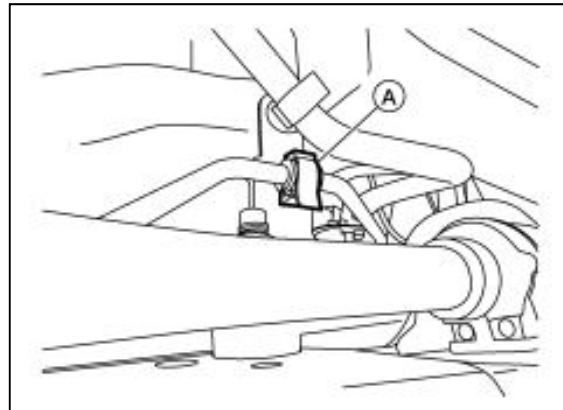

Figure 82

62. Separate the high pressure piping (A) from the steering gear (1).

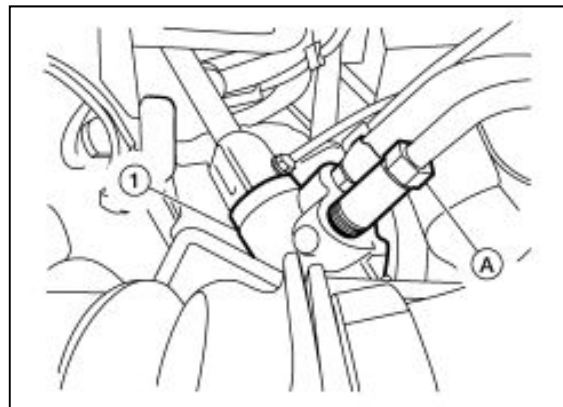

Figure 83

63. Remove the lower bolt, and then separate the steering intermediate shaft from the steering gear.

**NOTICE**

To avoid damage to the spiral cable, secure the steering wheel after separating the steering intermediate shaft from the steering gear. This can prevent damaging the spiral cable in the event the steering wheel is turned beyond the limited number of turns.



64. Remove the rear propeller shaft heat shield.

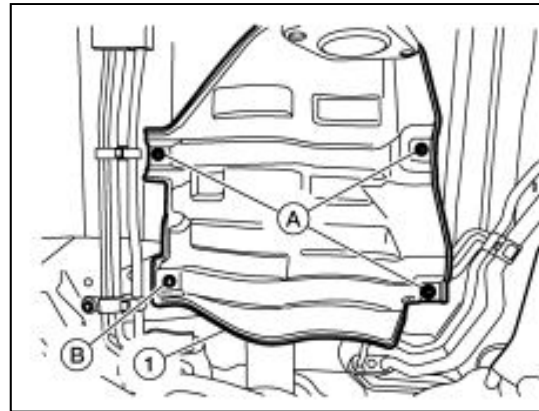

Figure 84

65. Remove the bolts, and then disconnect the rear propeller shaft from transfer assembly.
- Refer to the Rear Propeller Shaft "Exploded View" in the Driveline section of the ESM.
66. Using a suitable strap, secure the rear propeller shaft.

67. Remove bolts (A) from the transaxle mount.

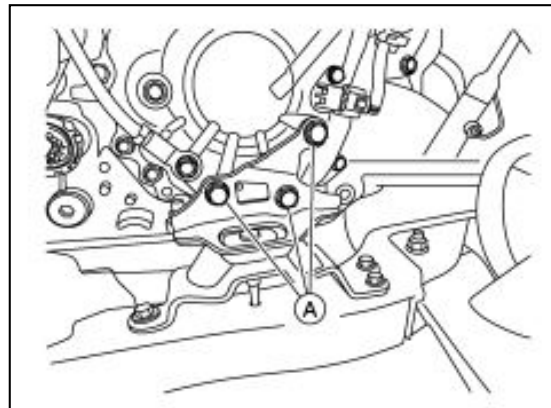

Figure 85

68. Remove bolt (A) and position ground (1) aside.

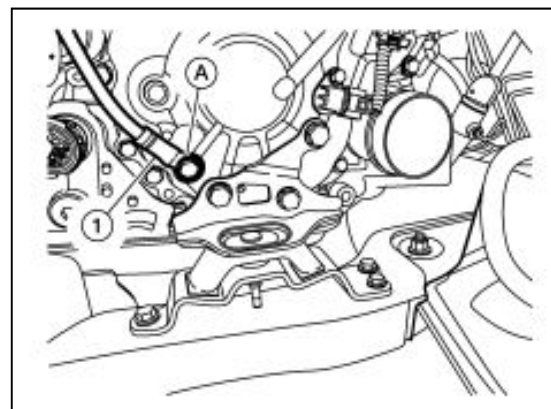

Figure 86

69. Remove the rear torque rod bolt.
- Refer to the Engine Assembly "Exploded View" in the Engine Mechanical section of the ESM.

70. Set the hydraulic lift table (A) or equivalent tool under the front suspension member.

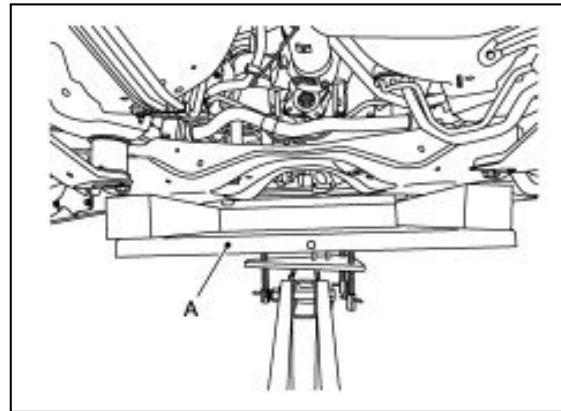

Figure 87

71. Remove the front suspension member bolts and the front suspension member stays.
- Refer to the Front Suspension Member "Exploded View" in the Front Suspension section of the ESM.

**CAUTION**

To avoid the risk of minor personal injury or property damage, secure the front suspension member to the hydraulic lift table (or equivalent tool) while removing it.

72. Lower the front suspension member.
73. Remove the bolt from the heater thermostat bracket.
- Refer to the Water Hose "Exploded View" in the Transmission and Transaxle section of the ESM.
74. Drain the coolant.
- Refer to "Changing Engine Coolant" in the Engine Cooling System section of the ESM.
75. Remove the CVT fluid cooler hose "A" and CVT fluid cooler hose "D" from the CVT oil warmer.
- Refer to the CVT Fluid Cooler System "Exploded View" in the Transaxle and Transmission section of the ESM.

76. Remove the CVT water hose "A" and CVT water hose "B" from the CVT oil warmer.
- Refer to the Water Hose "Exploded View" in the Transaxle and Transmission section of the ESM.

77. Disconnect the harness connector (A) from the heated oxygen sensor 2 (bank 2).

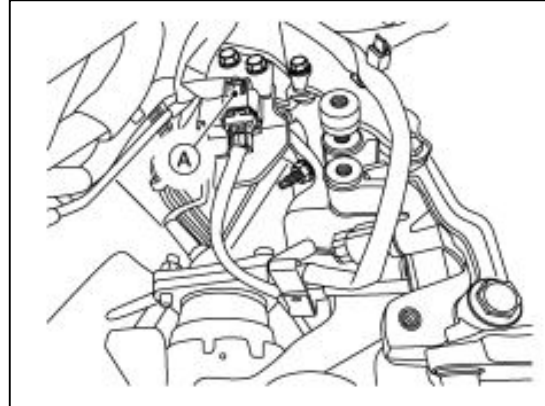

Figure 88

78. Separate the harness (1) from the bracket (2).

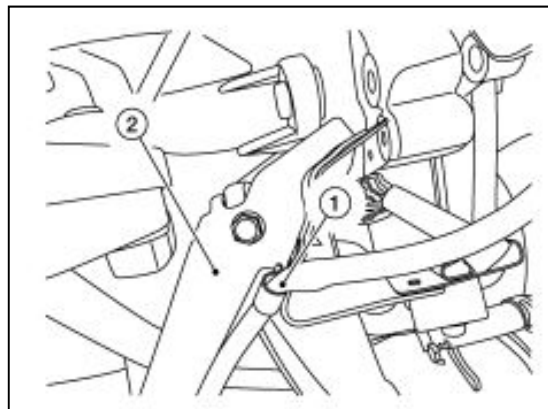

Figure 89

79. Remove the three way catalyst (bank 1).
- Refer to the Exhaust Manifold and Three Way Catalyst "Exploded View" in the Engine Mechanical section of the ESM.

**HINT:** Removal of the exhaust manifold is not necessary.

80. Remove bolts (A), and then remove the rear engine mount bracket (1).

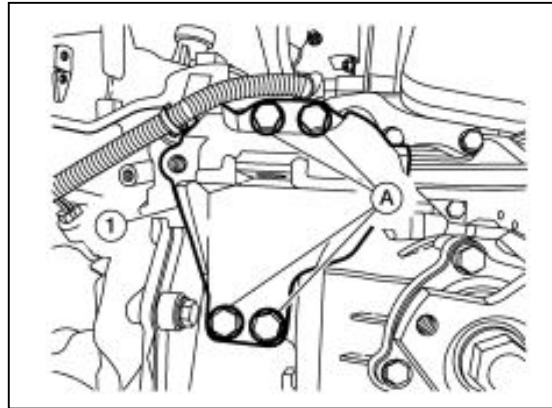

Figure 90

81. Remove the rear gusset and the transfer gusset.
- Refer to the Transfer Assembly "Exploded View" in the Driveline section of the ESM.

82. Remove bolts (A), (B) and (C).

**NOTICE**

To avoid damage to the CVT, do not damage the oil seal inside the CVT.

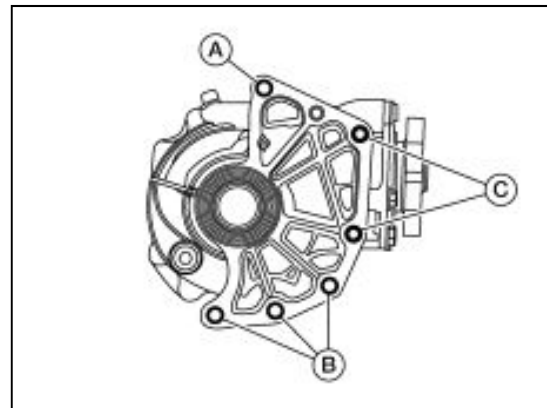

Figure 91

83. Remove the transfer assembly from the vehicle.
84. Using Special Tools NI-52389 and NI-53119, lower the engine and transaxle assembly until the transaxle assembly is low enough to clear driver's LH side frame rail.
85. Disconnect the harness connector from the starter motor "S" terminal.
- Refer to the Starter Motor "Exploded View" in the Starting System section of the ESM.
86. Remove the nut, and then remove "B" terminal harness and position aside.
- Refer to the Starter Motor "Exploded View" in the Starting System section of the ESM.

87. Remove the starter motor bolts, and then remove the starter motor.
- Refer to the Starter Motor "Exploded View" in the Starting System section of the ESM.

88. Using a suitable tool, release the clip.

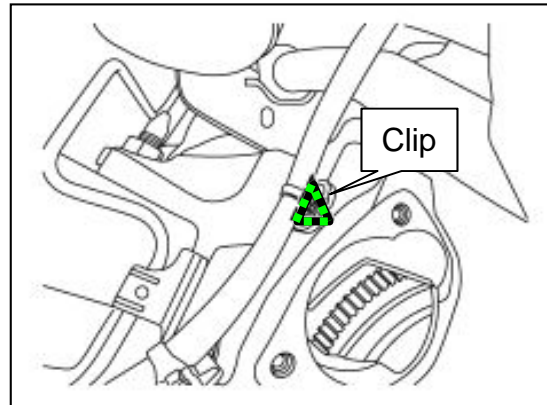

Figure 92

89. Remove bolt (A), and then remove the CVT fluid charging pipe (1).

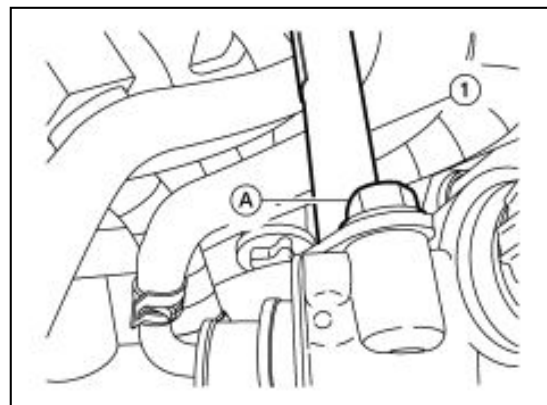

Figure 93

90. Separate the harness retainers from the transaxle assembly.

91. Remove bolt (A), and then remove the CVT fluid charging pipe (1).

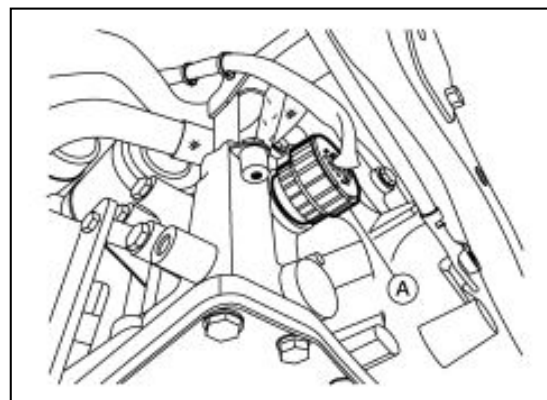

Figure 94

92. Disconnect the harness connector from the output speed sensor.
  - Refer to the Output Speed Sensor "Exploded View" in the Transaxle and Transmission section of the ESM.
93. Disconnect the harness connector from the primary speed sensor.
  - Refer to the Primary Speed Sensor "Exploded View" in the Transaxle and Transmission section of the ESM.
94. Disconnect the harness connector from the input speed sensor.
  - Refer to the Input Speed Sensor "Exploded View" in the Transaxle and Transmission section of the ESM.
95. Support the transaxle assembly using a suitable transmission jack and Special Tool NI-51307.

**CAUTION**

To avoid the risk of minor personal injury or property damage:

- Always secure the transaxle assembly to the transmission jack.
  - Do not lift or support the transaxle assembly using the bottom of the oil pan or damage can occur.
96. Remove bolts (A), (B), (C), and (D).

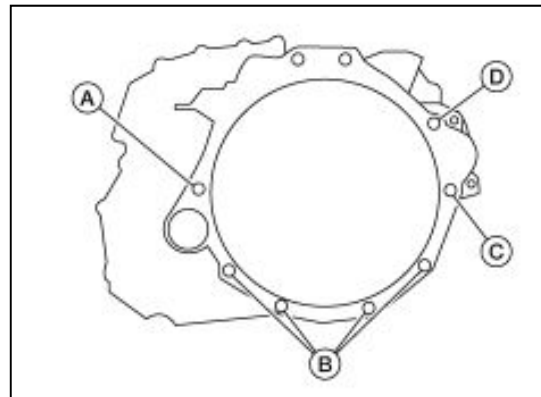

Figure 95

97. Separate the transaxle assembly from the engine assembly and lower the transaxle assembly.

**CAUTION**

To avoid the risk of minor personal injury or property damage, secure the torque converter to the transaxle while removing the transaxle to prevent the torque converter from falling.

## Installation (AWD)

98. Installation is in the reverse order of removal. Refer to **Inspection Before Installation (AWD)** below.

- If the same transaxle assembly will be reinstalled, replace the LH and RH side differential side oil seals.
  - Refer to the Differential Side Oil Seal "Exploded View" in the Transaxle and Transmission section of the ESM.
- If a new transaxle assembly is being installed, write down the serial number of the new transaxle assembly.

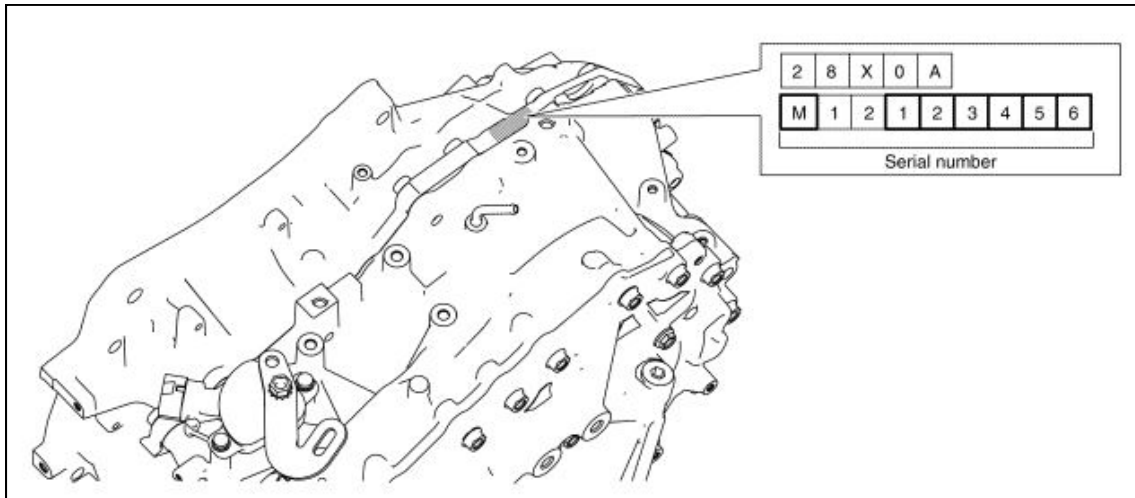

Figure 96

### **CAUTION**

To avoid the risk of minor personal injury or property damage:

- When replacing an engine or transaxle you must make sure any dowels are installed correctly during re-assembly.
- Improper alignment caused by missing dowels may cause vibration, oil leaks, or breakage of drivetrain components.
- Do not reuse O-rings or copper sealing washers.
- When turning crankshaft, turn it clockwise as viewed from the front of the engine.
- When tightening the nuts for the torque converter while securing the crankshaft pulley bolt, be sure to confirm the tightening torque of the crankshaft pulley bolt.
  - Refer to the Front Timing Chain Case "Removal and Installation" in the Engine Mechanical section of the ESM.
- After the torque converter is installed to the drive plate, rotate crankshaft several turns to check that the CVT rotates freely without binding.
- When installing the CVT to the engine, align the matching mark on the drive plate with the matching mark on the torque converter.
- Do not reuse differential side oil seals.

**HINT:**

- When installing the drive plate to torque converter nuts, tighten them temporarily, and then tighten the nuts to the specified torque.
  - Refer to "Exploded View" in the Transaxle and Transmission section of the ESM.
- Install the transaxle assembly and engine assembly mounting bolts according to the following standards.

Bolt No.	1		2		3		4		5
Number of bolts	1		2		1		1		4
Bolt length "ℓ"mm (in)	52 (2.05)	47 (1.85)	36 (1.42)	47 (1.85)	29 (1.14)	47 (1.85)	44 (1.73)	47 (1.85)	39.8 (1.57)
Tightening torque N·m (kg-m, ft-lb)	74.5 (7.6, 55)	62 (6.3, 46)	74.5 (7.6, 55)	62 (6.3, 46)	74.5 (7.6, 55)	62 (6.3, 46)	74.5 (7.6, 55)	62 (6.3, 46)	50.0 (5.1, 37)

Figure 97

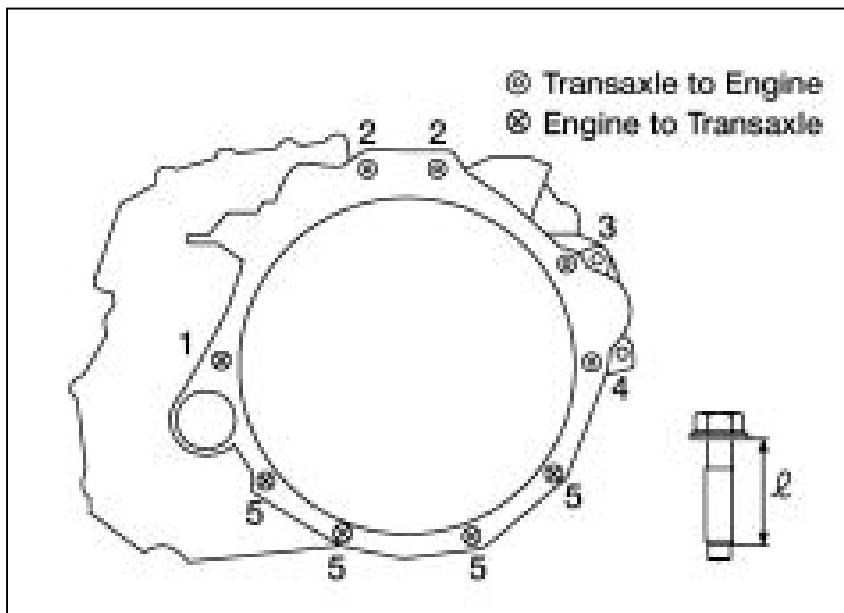

Figure 98



- When installing the transfer assembly to the transaxle, install the bolts following the standard below.

Bolt No.	(A)	(B)
Quantity	4	2
Bolt length "l" mm (in)	40 (1.57)	40 (1.57)

Figure 99

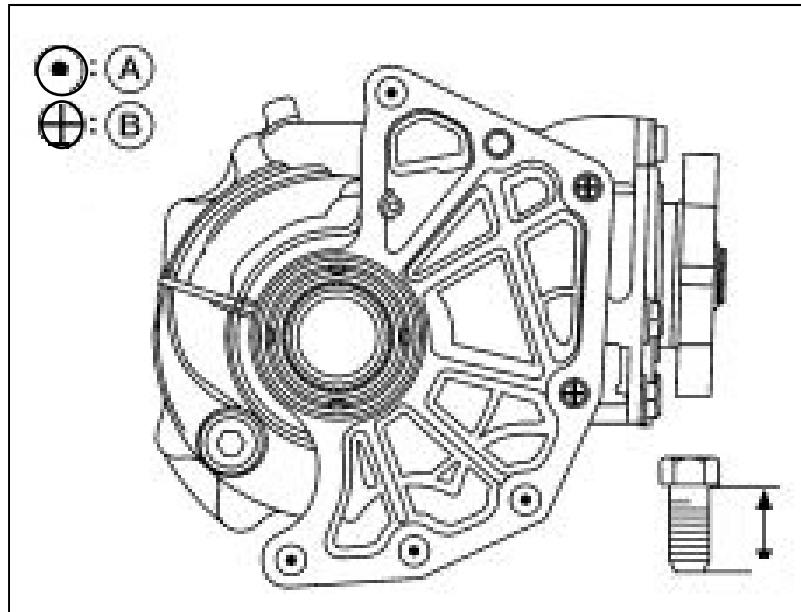

Figure 100

## Inspection Before Installation (AWD)

99. After inserting the torque converter into the CVT, check that dimension (A) is within the reference value limit.
- **Dimension A:** Refer to "Service Data and Specifications (SDS)" in the Transaxle and Transmission section of the ESM.
  - **B:** Scale
  - **C:** Straightedge

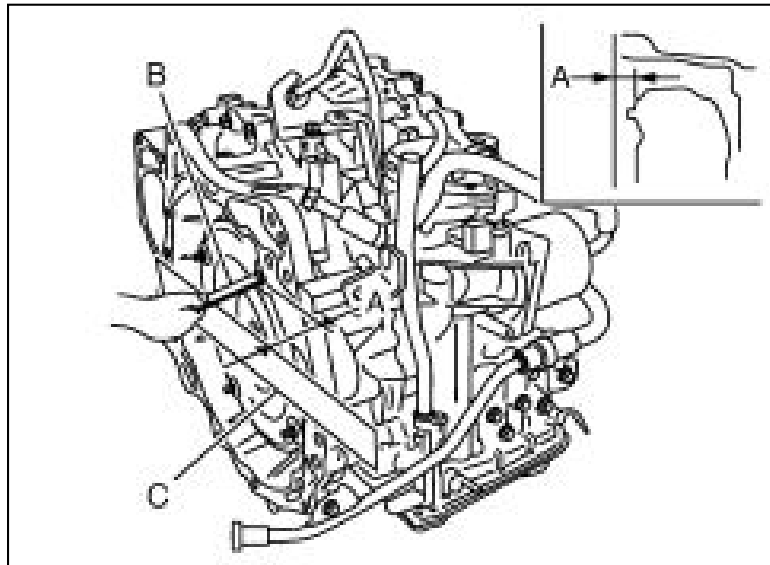

Figure 101

## Adjustment After Installation (AWD)

100. Perform the following:

- Adjust the CVT position.
  - Refer to "Adjustment" in the Transaxle and Transmission section of the ESM.
- Check and adjust the power steering fluid.
  - Refer to "Periodic Maintenance" in the Steering System section of the ESM.
- Check and adjust the transfer case fluid.
  - Refer to "Periodic Maintenance" in the Driveline section of the ESM.
- Check and adjust the engine coolant level.
  - Refer to "Changing Engine Coolant" in the Engine Cooling System section of the ESM.
- Adjust the CVT fluid level.
  - Refer to "Adjustment" in the Transaxle and Transmission section of the ESM.
- Perform the accelerator pedal released position learning.
  - Refer to "Description" in the Engine Control section of the ESM.
- Perform throttle valve closed position learning.
  - Refer to "Description" in the Engine Control section of the ESM.
- Perform a front wheel alignment.
  - Refer to "Wheel Alignment" in the Front Suspension section of the ESM.
- Perform adjustment of the steering angle sensor neutral position.
  - Refer to "Description" in the Brake Control System section of the ESM.

## Inspection After Installation (AWD)

101. Inspect the following items:

- Inspect for CVT fluid leakage.
  - Refer to "Inspection" in the Transaxle and Transmission section of the ESM.
- Inspect the transfer assembly for leaks.
  - Refer to "Inspection" in the Driveline section of the ESM.
- Inspect the power steering system for leaks.
  - Refer to "Inspection" in the Steering System section of the ESM.
- Inspect the CVT shifter position.
  - Refer to "Inspection" in the Transaxle and Transmission section of the ESM.
- Start the engine and inspect for coolant leaks.

## CLAIMS INFORMATION

Submit a Primary Part (PP) type line claim using the following claims coding:

DESCRIPTION	OP CODE	FRT
CVT R & I	JD01AA	(1)

- (1) The new procedure in the bulletin will alter the Flat Rate Time (FRT) for operations involving removal of the CVT from the vehicle. Refer to the current Infiniti Warranty Flat Rate Manual for the current FRTs.

## AMENDMENT HISTORY

PUBLISHED DATE	REFERENCE	DESCRIPTION
February 23, 2024	ITB24-001	Original bulletin published
March 22, 2024	ITB24-001A	2020 model year added to <b>APPLIED VEHICLES</b>