



TECHNICAL SERVICE BULLETIN

Single Rear Wheel Only - Boom/Hum/Moan Noise From Rear While Driving At Highway Speeds

24-2099

01 April 2024

This bulletin supersedes 22-2444. Reason for update: add 2024 model year vehicles

Model:

Ford 2015-2024 Transit	Single rear wheel
---------------------------	-------------------

Markets: North American markets only

Issue: Some 2015-2024 Transit vehicles equipped with RWD, single rear wheel only, and U-joints at the transmission flange and rear driveshaft may experience a boom/hum/moan noise from the rear while driving. This noise is most noticeable at highway speeds:

- 112-121 km/h (70-75 mph) for 4.10 axle ratio
- 121-128 km/h (75-80 mph) for 3.73 axle ratio
- 136-145 km/h (85-90 mph) for 3.31 axle ratio

The noise may also be present to a lesser degree at roughly half of the noted speeds. This may be due to a 2nd order driveline frequency transmitted through the rear driveshaft, rear axle and into the body through the leaf springs. To correct the condition, follow the Service Procedure to install a driveshaft torsional damper.

NOTE: The torsional damper will not resolve a vibration.

Action: Follow the Service Procedure to correct the condition on vehicles that meet all of the following criteria:

- 2015-2024 Transit
- Single rear wheel (SRW) only
- RWD
- Boom/hum/moan noise at highway speeds
- U-joint at the transmission flange and rear driveshaft

NOTE: This article does not apply to dual rear wheel (DRW) vehicles.

Parts

Service Part Number	Claim Quantity	Package Order Quantity	Description
LK4Z-4A263-C	1	1	Torsional Damper Kit

Special Tool(s)

Mastertech® Series MTS 4000 Driveline Balance and NVH Analyzer
--

Warranty Status: Eligible under provisions of New Vehicle Limited Warranty (NVLW)/Service Part Warranty (SPW)/Special Service Part (SSP)/Extended Service Plan (ESP) coverage. Limits/policies/prior approvals are not altered by a TSB. NVLW/SPW/SSP/ESP coverage limits are determined by the identified causal part and verified using the OASIS part coverage tool.

Labor Times

Description	Operation No.	Time
2015-2024 Transit: Diagnose, Inspect The Rear Driveshaft, Install A Driveshaft Torsional Damper And Torsion Damper Shield Includes Time To Remove The Pinion Nose Damper If	242099A	1.1 Hrs.

Equipped (Do Not Use With Any Other Labor Operations Outside Of This Article)		
2020-2024 Transit Additional Time To Remove And Install Running Boards When Necessary (Can Be Claimed With Operation A)	242099B	0.3 Hrs.

Repair/Claim Coding

Causal Part:	4A263
Condition Code:	D9

Service Procedure



CAUTION: This article does not apply to vehicles with DRW. If this service part kit is installed on DRW vehicles, the parking brake cable may contact the torsional damper shield due to insufficient clearance between the shield and the parking brake cable, leading to abrasion of the parking brake cable. Over time, abrasion of the parking brake cable could result in cable failure. If the parking brake cable fails, the park brake will no longer function to hold the vehicle in place creating the risk of unintended vehicle movement.

1. Does the vehicle exhibit an audible noise (boom/hum/moan) at the specified speed ranges noted above in the Issue statement?
 - (1). Yes - proceed to Step 2.
 - (2). No - this article does not apply. Refer to WSM, Section 205-01 for further diagnostic procedures.
 2. Inspect the rear driveshaft, driveshaft joints, driveshaft center bearing(s) and slip yoke splines for damage or wear. Refer to WSM, Section 205-01. Is there evidence of damage or wear to the driveshaft, driveshaft U-joints or slip yoke splines?
 - (1). Yes - refer to WSM, Section 205-01. Repair damage/wear and retest. If vehicle continues to exhibit the noise, proceed to Step 3. If the noise has been resolved, this article does not apply.
 - (2). No - proceed to Step 3.
 3. Using the Mastertech® Series MTS 4000 Driveline Balance and NVH Analyzer (Vetronix) or equivalent, analyze the noise. Does the analysis identify the concern as a driveline vibration?
 - (1). Yes - refer to WSM, Section 205-01 to resolve the vibration and retest. If vehicle continues to exhibit a noise, proceed to Step 4. If there is no audible noise present, this article does not apply.
 - (2). No - proceed to Step 4.
 4. Mark the pinion flange and rear driveshaft U-joint to enable correct indexing of the driveshaft during installation. Refer to WSM, Section 205-01.
 5. Remove the driveshaft to axle pinion flange bolts. Clean the bolts of old Loctite with wire-wheel or solvent. With a suitable strap, support the driveshaft so there is no undue stress applied to the rear driveshaft-to-transmission output flange joint or rear driveshaft center bearing(s). Refer to WSM, Section 205-01 Removal and Installation > Rear Driveshaft.
- NOTE:** The maximum articulation of any U-joint is 10 degrees. If the driveshaft U-joint is articulated further than the maximum allowed, damage may occur.
6. Inspect the pinion flange to driveshaft mating surface for any debris or excessive rust and clean as necessary.
 7. Install the driveshaft torsional damper on the axle pinion flange. (Figure 1)

Figure 1

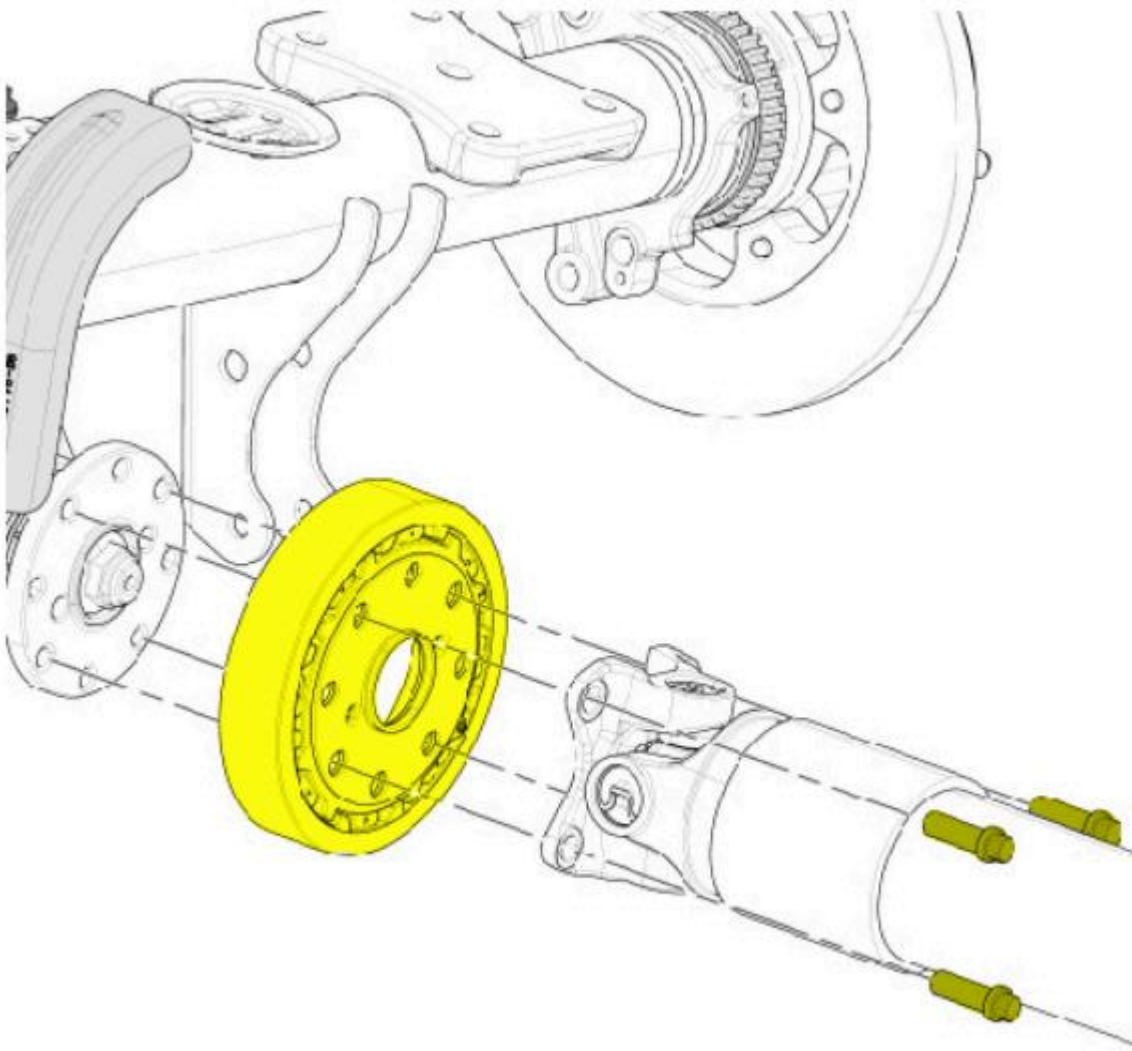

E337352

8. Align the index mark on the driveshaft and rear drive pinion flange and reinstall the driveshaft. Make sure the driveshaft fits securely over the raised flange on the torsional damper.

(1). Apply Loctite 263 to each of the 4 cleaned bolts. (Loctite to be applied in the engagement area, first 7 threads) Install the driveshaft attaching bolts and tighten to 115 Nm (85 lb-ft). Refer to [WSM](#), Section 205-01. (Figure 1)

9. The torsional damper kit may come with a shield. If there is a shield provided, discard it as it is not required.

© 2024 Ford Motor Company

All rights reserved.

NOTE: The information in Technical Service Bulletins is intended for use by trained, professional technicians with the knowledge, tools, and equipment to do the job properly and safely. It informs these technicians of conditions that may occur on some vehicles, or provides information that could assist in proper vehicle service. The procedures should not be performed by "do-it-yourselfers". Do not assume that a condition described affects your car or truck. Contact a Ford or Lincoln dealership to determine whether the Bulletin applies to your vehicle. Warranty Policy and Extended Service Plan documentation determine Warranty and/or Extended Service Plan coverage unless stated otherwise in the TSB article. The information in this Technical Service Bulletin (TSB) was current at the time of printing. Ford Motor Company reserves the right to supersede this information with updates. The most recent information is available through Ford Motor Company's on-line technical resources.