

ATTENTION:

- GENERAL MANAGER
- PARTS MANAGER
- CLAIMS PERSONNEL
- SERVICE MANAGER

IMPORTANT - All Service Personnel Should Read and Initial in the boxes provided, right.

© 2023 Subaru of America, Inc. All rights reserved.



QUALITY DRIVEN® SERVICE

SERVICE BULLETIN

APPLICABILITY: 2019MY Legacy & Outback **NUMBER:** 15-318-24R
 2019-21MY WRX/STI **DATE:** 02/23/24

SUBJECT: Data Communication Module (DCM) Bypass Box **REVISED:** 04/17/24

INTRODUCTION:

This bulletin announces the warranty extension for the Data Communication Module (DCM) up to 8 years (96 months) or 150,000 miles (whichever comes first) to address dead battery resulting from excessive dark current draw caused by the DCM, due to internal memory corruption. Effective from the date of customer notification, ALL affected vehicles, regardless of mileage or Warranty Start Date will be covered for a period of one (1) year.

This bulletin also announces the availability of the DCM Bypass Box designed to be used as an alternative replacement part for DCM in vehicles with no active STARLINK subscription.

- This extension will cover the replacement of the DCM for vehicles with an “Active” STARLINK subscription if the DCM is confirmed to be the cause of the excessive dark current draw.
- The extension will also cover the testing, recharging/replacement of the battery if the DCM is found to be the root cause of the excessive dark current draw. Battery test code is required for the claim entry.
- For “Unsubscribed” vehicles, without a STARLINK subscription, with a confirmed excessive dark current draw from the DCM, this extension will cover the installation of a DCM bypass box.
- Customers who received the bypass box have the option to request a replacement DCM once new DCM inventory is available, which is estimated as September 2025. This extension will cover removal of the bypass box and installation of a new DCM. This request must be documented with a Subaru retailer at the time of the initial repair.
- All inspections and repairs must be completed prior to the expiration of this Warranty extension.
- Customers who have paid for DCM or DCM bypass box replacement prior to the release of this extension are eligible for reimbursement. Details of reimbursement procedure is provided in the customer letter which is added to the end of this bulletin.

CAUTION: VEHICLE SERVICING PERFORMED BY UNTRAINED PERSONS COULD RESULT IN SERIOUS INJURY TO THOSE PERSONS OR TO OTHERS.

Subaru Service Bulletins are intended for use by professional technicians ONLY. They are written to inform those technicians of conditions that may occur in some vehicles, or to provide information that could assist in the proper servicing of the vehicle. Properly trained technicians have the equipment, tools, safety instructions, and know-how to do the job correctly and safely. If a condition is described, DO NOT assume that this Service Bulletin applies to your vehicle, or that your vehicle will have that condition.

Subaru of America, Inc. is ISO 14001 Compliant

ISO 14001 is the international standard for excellence in Environmental Management Systems. Please recycle or dispose of automotive products in a manner that is friendly to our environment and in accordance with all local, state and federal laws and regulations.

Continued...

PART INFORMATION:

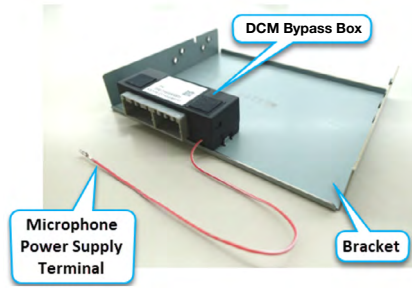

Part Description	Part Number
DCM BYPASS BOX	86229AL400

STARLINK SUBSCRIPTION CONFIRMATION:

ALWAYS confirm the STARLINK subscription status prior to proceeding with any service procedures. This DCM Bypass Box installation is for vehicles without any active STARLINK subscription. ALWAYS confirm the STARLINK subscription status prior to performing the DCM bypass box installation. This bypass box (86229AL400) is **ONLY** orderable through PRIME. There is no need to contact PICs for release.

IMPORTANT NOTE: If the vehicle has an active STARLINK subscription and excessive dark current draw from the DCM, the Bypass Box is not required, and a Data Communication Module must be used as replacement part. Please contact SOA PICs team after placing the order through the normal ordering channels with the VIN and order number to have the VIN verified for the subscription and have the order released. No changes have been made to the DCM replacement procedure. Refer to the applicable Subaru Service Manual for DCM replacement.

CONFIRMING SUBSCRIPTION STATUS USING SNET VEHICLE INQUIRY:

1. Enter the subject Vehicle Identification Number (VIN) into the VIN search box and click the search button.

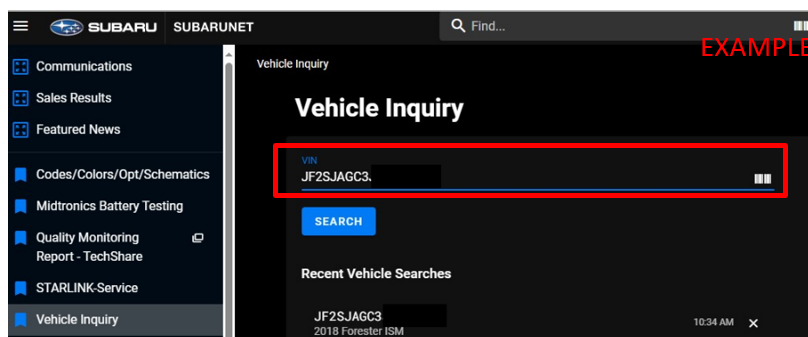

2. Select the Connected Vehicle Subscriptions drop down.

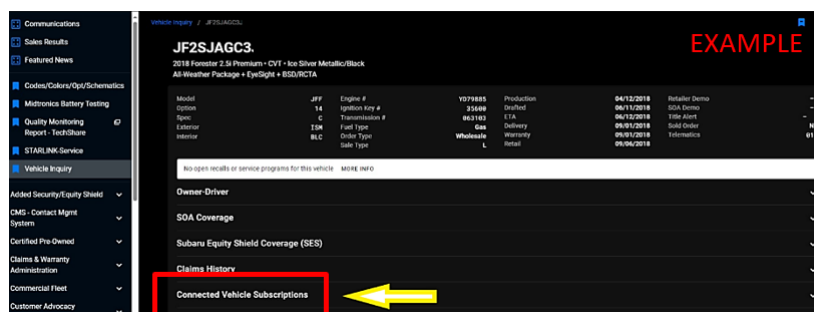

Continued...

3. Confirm the status reads “**Inactive**” prior to proceeding. If the status reads “**Active**,” the vehicle has an active STARLINK subscription and does not qualify for the repair procedures outlined in this bulletin.

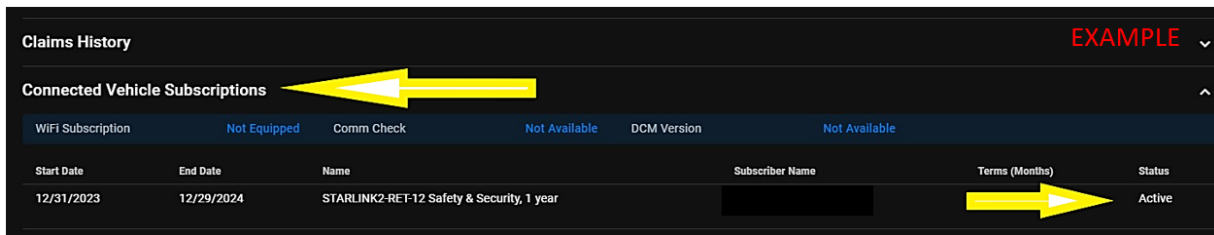

CONFIRMING SUBSCRIPTION STATUS USING SUBARU SELECT MONITOR:

4. Connect the applicable Subaru Select Monitor (SSM) to the vehicle. Read the Subscription status of the DCM located in the “Work Support” menus. Confirm the subscription status reads “**Unsubscribed**” prior to proceeding. If the status reads “**Subscribed**,” the vehicle has an active STARLINK subscription and does not qualify for **Bypass Box installation and will require a DCM replacement as per the applicable Subaru Service Manual.**

EXAMPLE	Item	Value
✓	Subscription Status	Subscribed
✓	Remote Battery Charging Timer Active	TRUE
✓	Curfew Active	TRUE
✓	Driving Recorder Active	TRUE

DCM BYPASS BOX INSTALLATION CONFIGURATION:

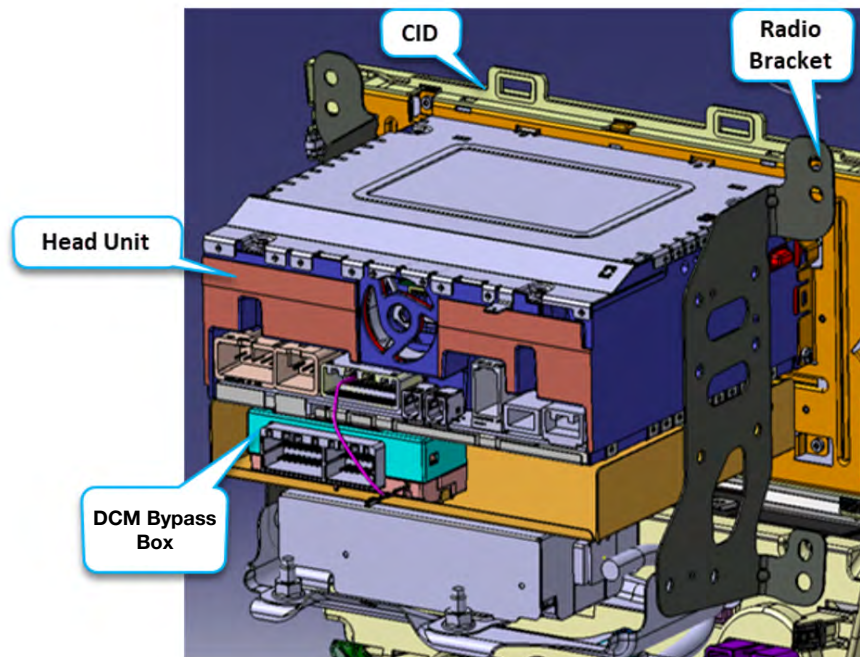

Continued...

LEGACY & OUTBACK DCM REMOVAL PROCEDURE / INFORMATION:

IMPORTANT: This procedure is for vehicles without any active STARLINK subscription. ALWAYS confirm the STARLINK subscription status prior to performing the procedures outlined below.

STEP 1: Refer to the applicable Service Manual and review: General Description > Repair Contents > Action required before & after Battery Disconnect. Additionally, record any stored seat position(s) before proceeding. Relearn any seat position memory after work is complete. If the power rear gate (PRG) height has been customized, that position must also be noted and relearned.

STEP 2: CAREFULLY disconnect the battery sensor from the negative ground terminal and wait at least 60 seconds before continuing.

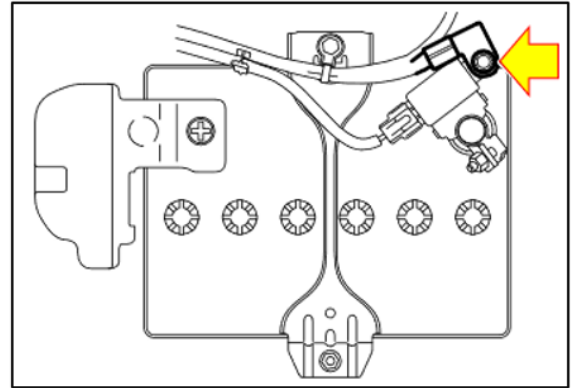

STEP 3: Remove the Center Grille Assembly.

- A. Release the clips and claws.
- B. Disconnect the connector and remove the Grille Assembly.
- C. Disconnect and remove the hazard switch.

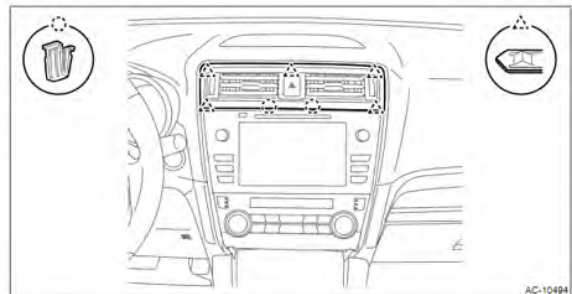

STEP 4: Remove the Heater Control Assembly.

- A. Release the clips and claws.
- B. Remove the panel.
- C. Remove the mounting screws.
- D. Detach the heater control assembly.

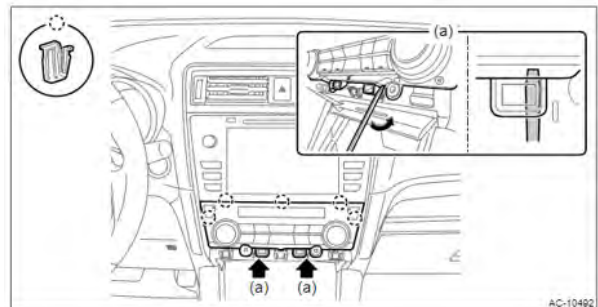

CAUTION: A flat head screwdriver with protective tape can be used as shown in the right image. Use special care to not damage the heater control assembly.

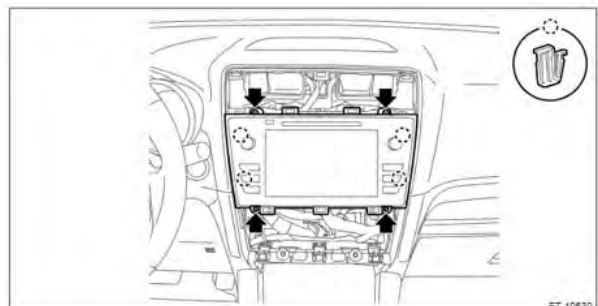

Continued...

STEP 5: Remove the audio assembly.

- A. Remove the mounting screws.
- B. Release the mounting clips.
- C. Disconnect all electrical connections.
- D. The audio assembly can then be removed.

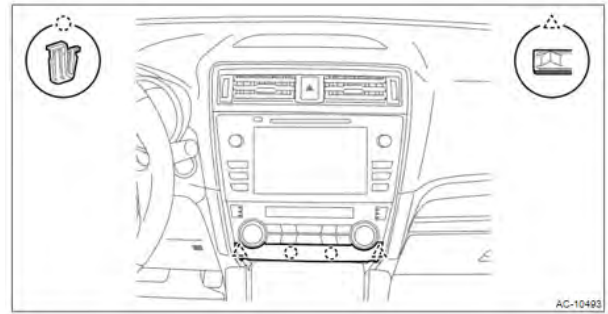

STEP 6: Remove the DCM.

- A. CAREFULLY remove the bracket mounting screws.
- B. Remove the DCM and the backup module assembly together.

CAUTION: Be mindful to not cause any damage to the mounting screws during removal. The mounting screws are to be reused.

STEP 7: Refer to the DCM Bypass Box Installation section of this bulletin on page #8.

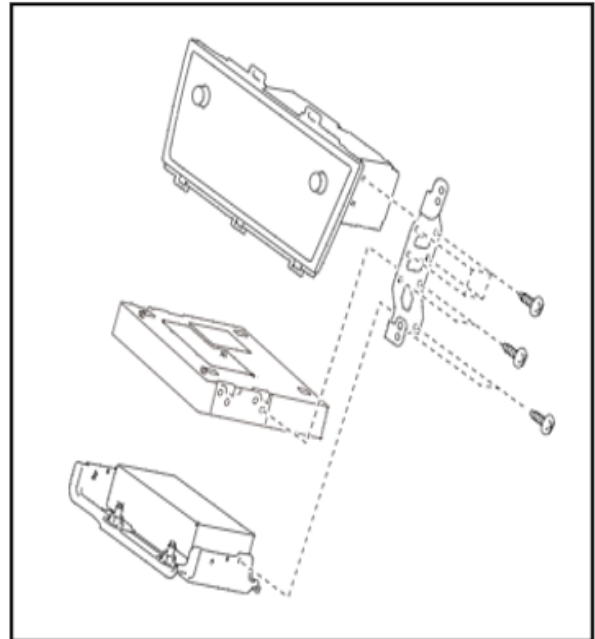

WRX DCM REMOVAL PROCEDURE / INFORMATION:

IMPORTANT: This procedure is for vehicles without any active STARLINK subscription. ALWAYS confirm the STARLINK subscription status prior to performing the procedures outlined below.

STEP 1: Refer to the applicable Service Manual and review: General Description > Repair Contents > Action required before & after Battery Disconnect. Additionally, record any stored seat position(s) before proceeding. Relearn any seat position memory after work is complete. If the power rear gate (PRG) height has been customized, that position must also be noted and relearned.

STEP 2: CAREFULLY disconnect the battery sensor from the negative ground terminal and wait at least 60 seconds before continuing.

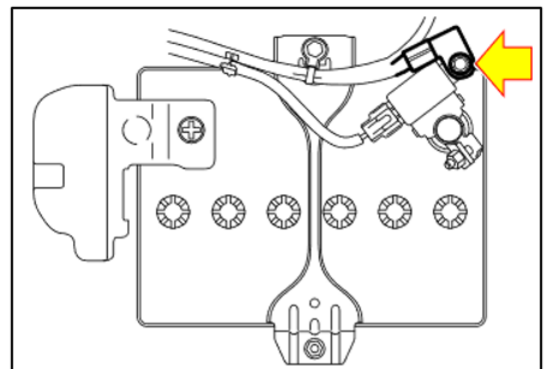

Continued...

STEP 3: Using a plastic trim tool, remove the left side instrument panel cover.

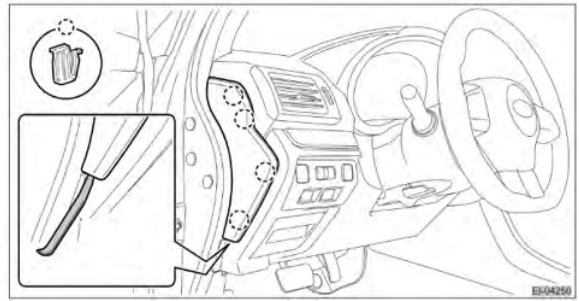

STEP 4: Remove the left inner and outer lower instrument panels.

- A. Remove the mounting screws.
- B. Release the mounting clips and claws.
- C. Pull both panels toward the rear of the vehicle.
- D. Disconnect all electrical connections.

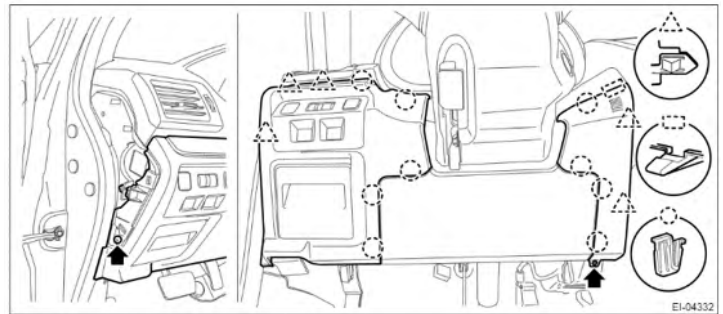

CAUTION: ALWAYS pull the panels toward the rear of the vehicle. Pulling in an upward or downward direction may cause damage to the mounting claws.

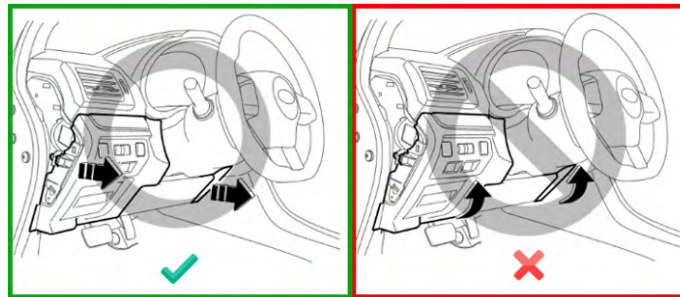

STEP 5: Remove the knee airbag module.

- A. Remove the mounting nuts.
- B. CAREFULLY disconnect the electrical connection.

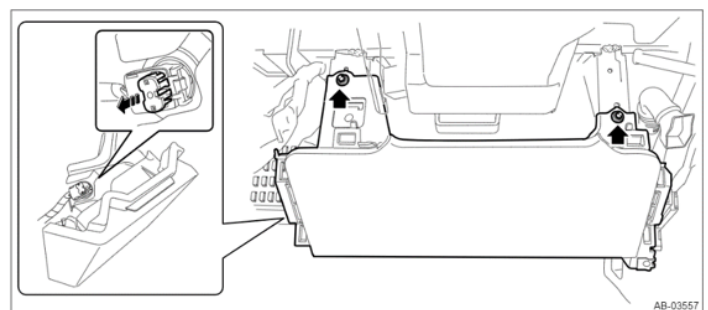

STEP 6: Remove the glove box assembly.

- A. Apply protective tape to the lower center panel section shown as (a) in the right image.
- B. Disconnect the damper from the glove box.
- C. Release the stoppers and pull the glove box toward the rear of the vehicle.

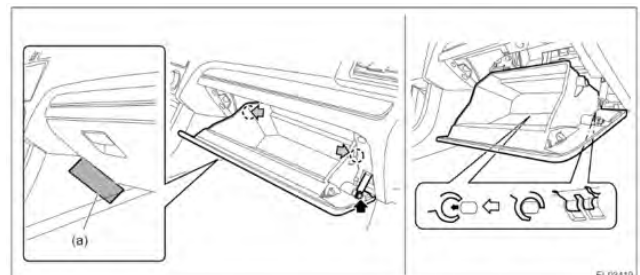

Continued...

STEP 7: Remove the glove box backing panel.

- A. Using a plastic trim tool, remove the right side instrument panel cover.
- B. Release the clips and removed the instrument panel ornamental trim.

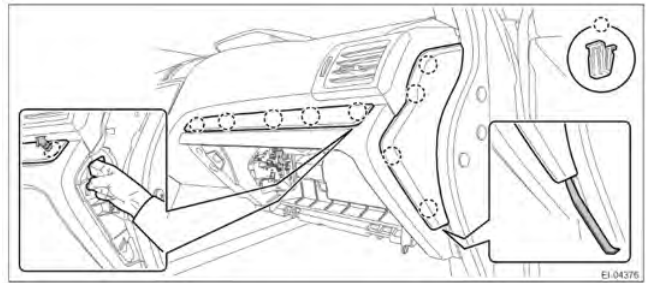

TIP: The instrument panel ornamental trim can be removed by applying pressure from the backside.

- C. Remove the glove box LED and disconnect the electrical connection.
- D. Removed the mounting screws.
- E. Release the claws and harness clamp.
- F. The glove box backing panel can then be removed.

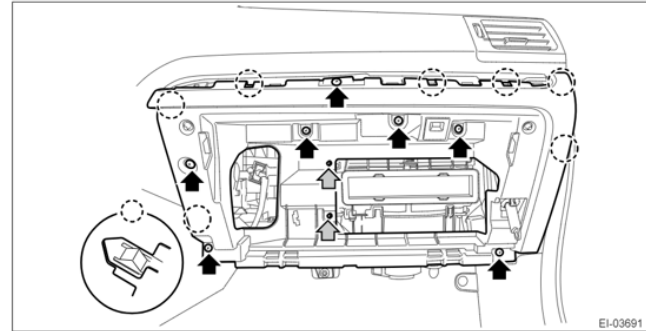

STEP 8: Remove the center grille assembly.

- A. Apply protective tape to the instrument panel section shown as (a) in the right image.
- B. Release the claw using a plastic trim tool or a clip removal to with protective tape applied to the contact area.
- C. Disconnect the electrical connector and remove the center grille assembly.

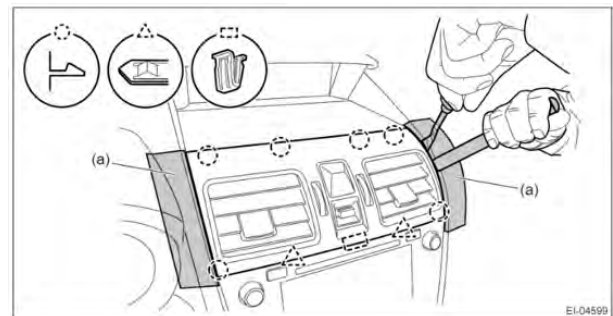

STEP 9: Remove the audio assembly.

- A. Apply protective tape the center storage area section indicated as (a) in the lower right image.
- B. Remove the mounting screws and bolts.
- C. Release the mounting claws and partially remove the audio assembly to gain access to the electrical connections.

CAUTION: If the antenna cable interferes with the removal side mounting bolts, move the antenna cable before attempting to remove the bolts.

- D. Disconnect the electrical connectors and remove the audio assembly.

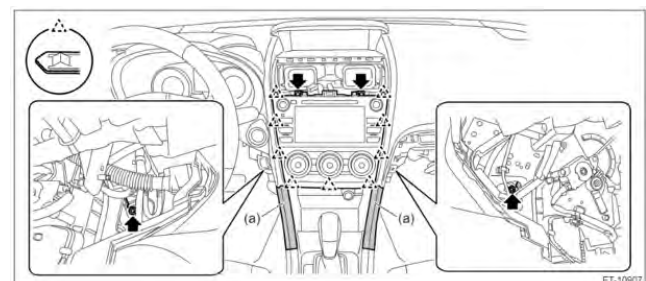

Continued...

STEP 10: Remove the DCM.

- A. CAREFULLY remove the bracket mounting screws.
- B. Remove the DCM and the backup module assembly together.

CAUTION: Be mindful to not cause any damage to the mounting screws during removal. The mounting screws are to be reused.

STEP 11: Refer to the DCM Bypass Box Installation section of this bulletin on page #8.

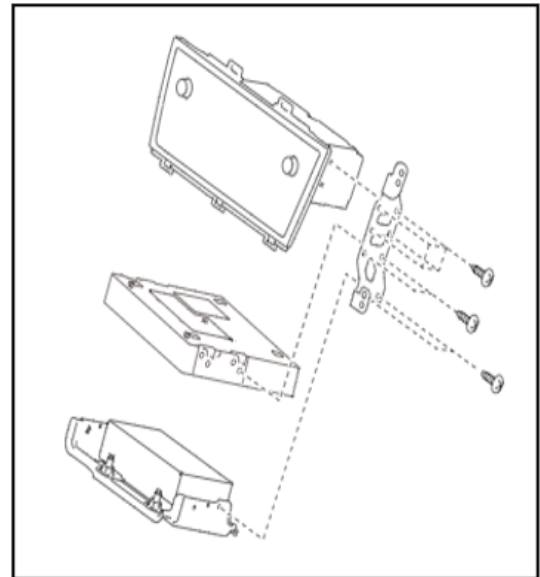

DCM BYPASS BOX INSTALLATION:

STEP 1: Mount the DCM Bypass Box with the brackets in place of the DCM.

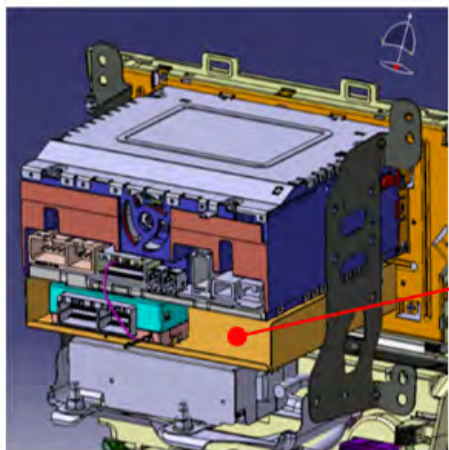

DCM Bypass Box

Back Side View

On LEGACY & OUTBACK, the lower mounting holes labeled with "←LEGACY/OUTBACK" are to be used.

On WRX, the upper mounting holes labeled with "WRX→" are to be used.

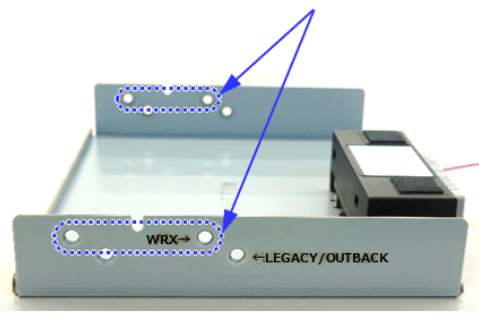
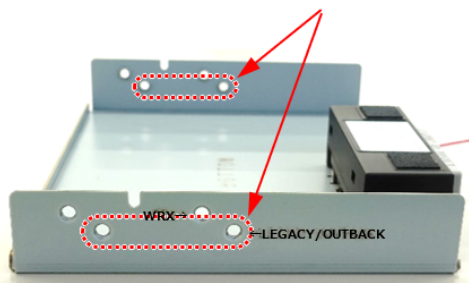

Left side of the DCM Bypass Box.

Continued...

STEP 2: Locate pin #4 of head unit connector i87.

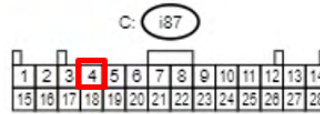
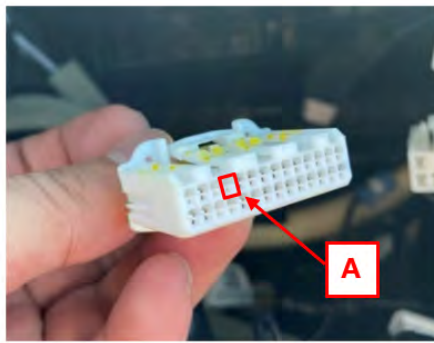

View from direction A

STEP 3: Using a small precision screwdriver or pin terminal tool, release and raise the lock located on the back on the connector. The lock release points are located as (a) in the image below.

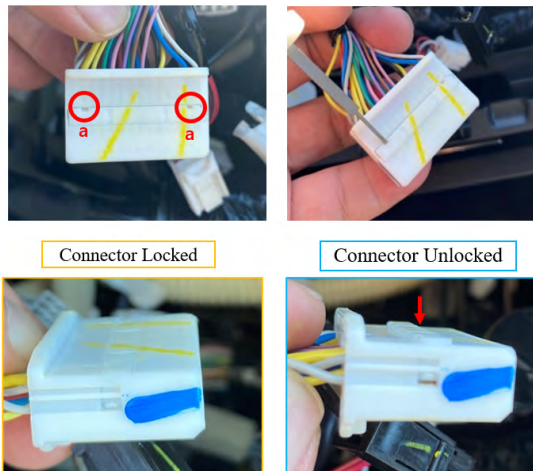

Connector Locked

Connector Unlocked

STEP 4: Insert the microphone power terminal into pin #4 of head unit connector i87.

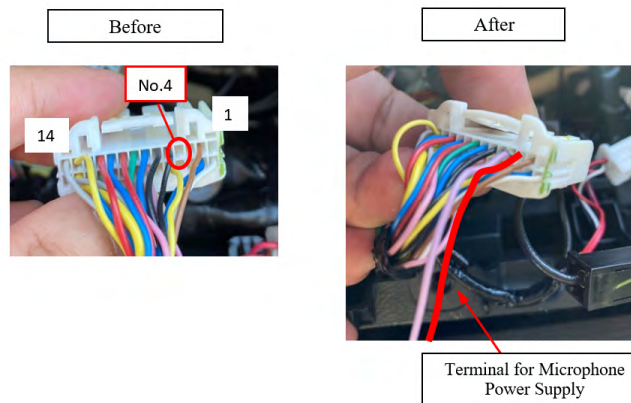

Before

After

Terminal for Microphone Power Supply

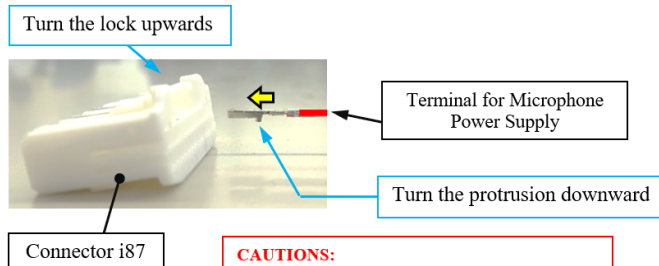

Turn the lock upwards

Terminal for Microphone Power Supply

Turn the protrusion downward

Connector i87

- CAUTIONS:**
- Pay attention to the direction of the terminals.
 - Insert from the same direction as other wires.

Continued...

STEP 5: Push the lock portion back into the connector. Confirm the connector is fully locked and the newly installed wire is secure.

Connector Fully Locked

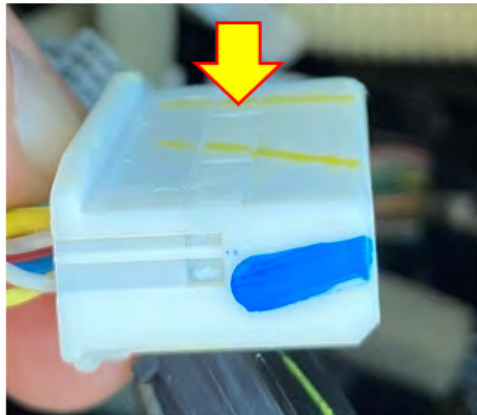

STEP 6: Secure the newly installed wire to the power harness with vinyl tape.

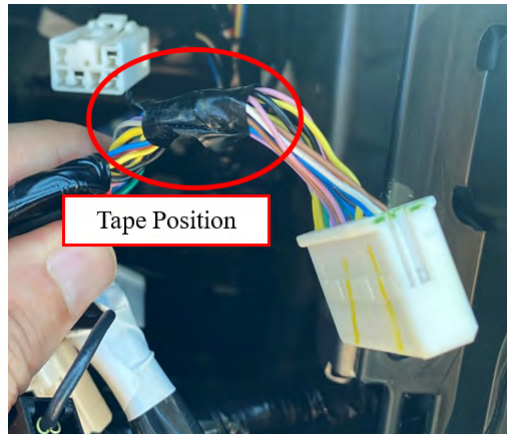

STEP 7: Bundle the reimagining three antenna connectors to +the harness with vinyl tape.



Continued...

STEP 8: Reinstall all parts in the reverse order of disassembly. Remove all protective tape.

IMPORTANT NOTE: Whenever reconnecting the ground cable terminal to the battery sensor, torque to 7.5Nm (5.5ft.-lbs. or 66inch-lbs.) while supporting the sensor with the other hand as outlined in the applicable Service Manual under: STARTING/CHARGING SYSTEMS > Battery Sensor.

STEP 9: Proceed to the Function Check portion of this bulletin on page #12.

FUNCTION CHECK:

STEP 1: Connect the Subaru Select Monitor (SSM) and perform and all systems fault scan. Confirm there **are** no DTCs.

STEP 2: Confirm sound is emitting from all the speakers. Pay special attention the front tweeter speakers.

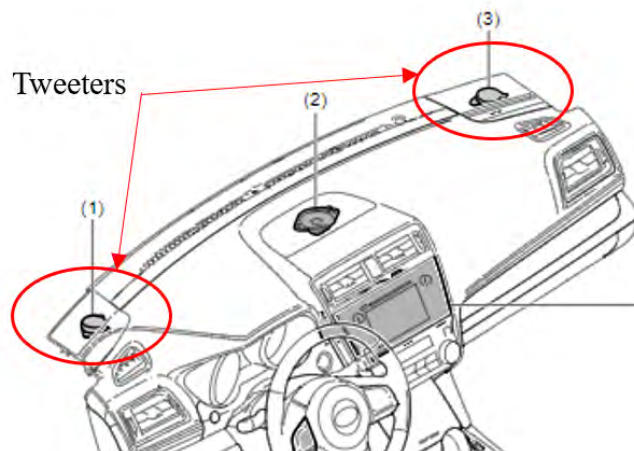

STEP 3: Confirm the microphone is working using the Service Diagnostics Mode.

- A. Turn the ignition switch to ACC.
- B. Press the “Tune/Scroll” knob six times while pressing the “HOME” button.
- C. Select “Function Check”.



Continued...

D. Select “Microphone”.

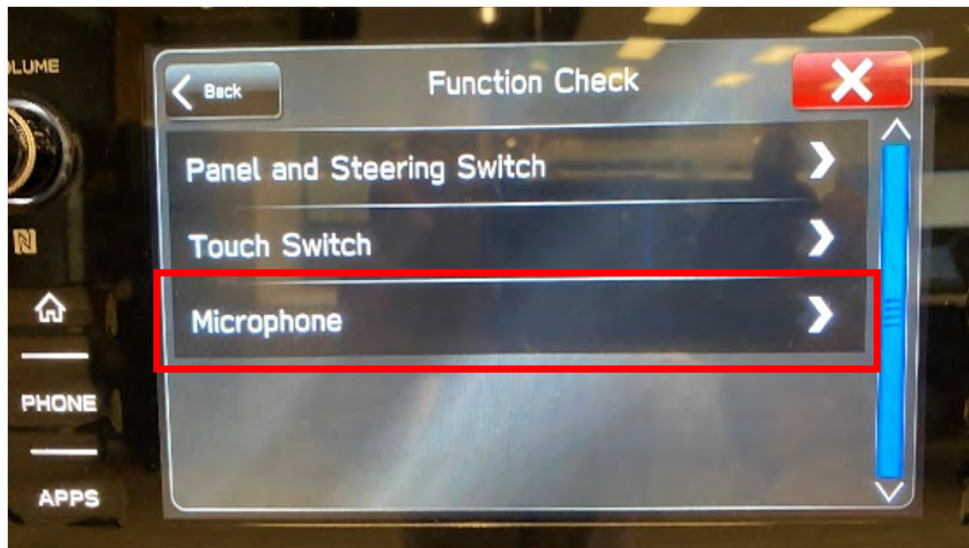

E. Confirm “Mic 1 Input Level” and “Mic 2 Input Level” are operational.

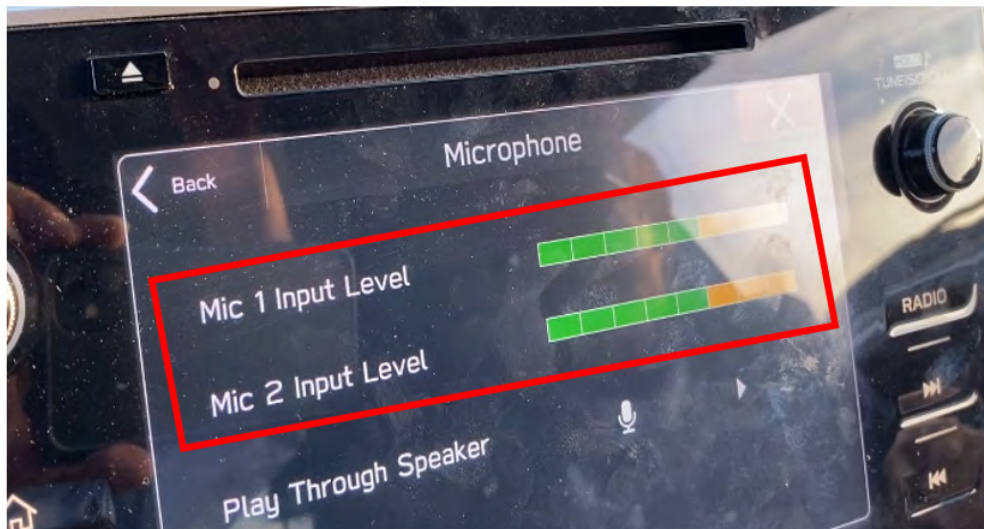

DCM RECONNECTION:

NOTE: DCM Reconnection is not part of the DCM bypass box placement procedure and needs to be performed **ONLY** if the customer with a DCM bypass box installed decides to subscribe to telematics services at some point in future.

In a case when STARLINK is to be re-subscribed for a vehicle with a DCM Bypass Box installed, the following procedure is required.

STEP 1: Disconnect the ground terminal from the battery sensor.

STEP 2: Remove the center grille assembly.

STEP 3: Remove the heater control assembly.

Continued...

STEP 4: Remove the audio assembly.

- A. Remove the screws and release the clip.
- B. Disconnect the connector and remove the audio assembly.
- C. Cut the microphone power wire (color: red) at the end of connector i87 pin #4.

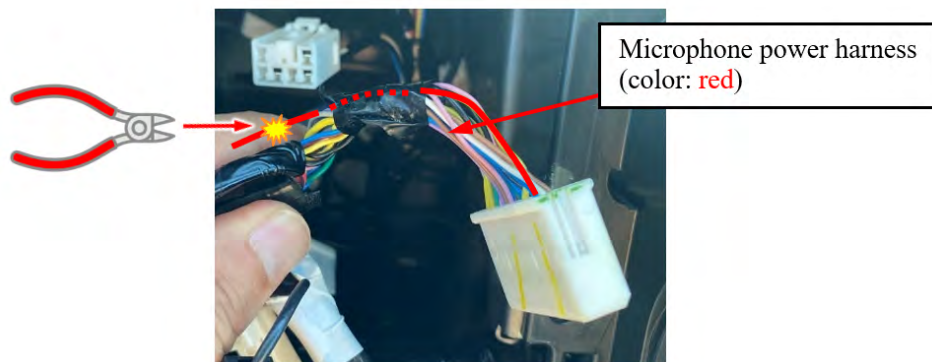

- D. Bundle the cut red wire for the microphone into the vehicle harness so the cut end is covered.

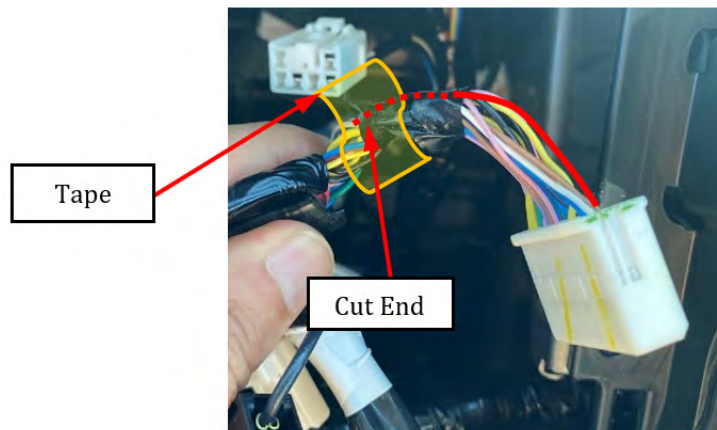

- E. Remove the tape from the three bundled antenna connectors.

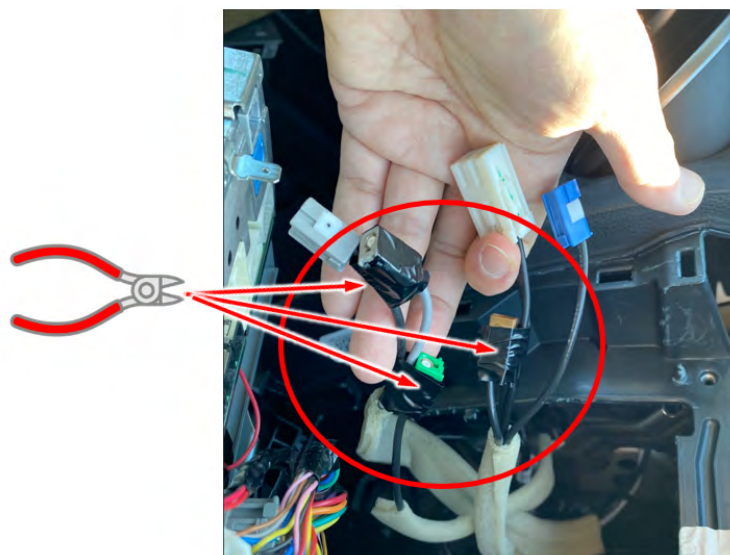

Continued...

STEP 5: Remove the DCM Bypass Box.

- A. CAREFULLY remove the mounting screws.
- B. Remove the DCM Bypass Box.

STEP 6: Install the DCM.

- A. Install the backup battery.
- B. Install the DCM.
- C. Install the audio assembly or navigation assembly.
- D. Install the heater control assembly.
- E. Install the center grille assembly.
- F. Connect the ground terminal to battery sensor. Refer to STIS: REPAIR CONTENTS > NOTE > BATTERY.
- G. Perform the registration procedure if the DCM is replaced with a new part. Refer to STIS: ENTERTAINMENT & MONITORING > Telematics System > OPERATION
- H. Check the LED lighting condition of the Telematics button. Refer to STIS: TELEMATICS SYSTEM > (DIAGNOSTICS) > Check List for Interview > CHECK > LED ILLUMINATION STATUS LIST

WARRANTY / CLAIM INFORMATION:

For vehicles within the Basic New Car Limited Warranty period or covered by an active Added Security Gold Plan, this repair may be submitted using the following claim information:

Labor Description	Labor Operation #	Labor Time	Fail Code
TEST AND REPLACE DCM WITH DCM BYPASS BOX	B067-915	1.1	TQQ-48

The Warranty Extension for the Data Communication Module is extended from the original Warranty term of 3 years (36 months) or 36,000 miles to 8 years (96 months) or 150,000 miles (whichever comes first).

Original Warranty	Warranty Extension
3 Years / 36K Miles	8 Years / 150K Miles

Labor Description	Labor Operation #	Labor Time	Fail Code
TEST AND REPLACE DCM WITH DCM BYPASS	B067-915	1.1	TQQ-43
BATTERY TEST & REPLACEMENT*	C800-203	.4	
OR			
BATTERY TEST & CHARGE - NO REPLACEMENT	C800-223	.3	

*Battery test code is required for claim entry

Continued...

Labor Description	Labor Operation #	Labor Time	Fail Code
WARRANTY EXTENSION – TEST AND REPLACE TELEMATICS UNIT	B067-086	.9	ZVW-43
BATTERY TEST & REPLACEMENT*	C800-203	.4	
OR			
BATTERY TEST & CHARGE - NO REPLACEMENT	C800-223	.3	

***Battery test code is required for claim entry**

IMPORTANT REMINDERS:

- SOA strongly discourages the printing and/or local storage of service information as previously released information and electronic publications may be updated at any time.
- Always check for any open recalls or campaigns anytime a vehicle is in for servicing.
- Always refer to STIS for the latest service information before performing any repairs.

Continued...



Important Notice:

Warranty Extension for the Telematics Data Communications Module (DCM) for certain 2019 MY Legacy, Outback Vehicles 2019-2021 MY WRX/STI Vehicles

Dear Subaru Owner:

As part of Subaru of America's dedication to customer satisfaction, Subaru of America, Inc. (SOA) is announcing a Warranty Extension for the DCM on certain 2019 MY Legacy, Outback vehicles and 2019-2021 MY WRX/STI vehicles sold or leased in the United States.

Affected vehicles are equipped with a DCM and may experience a dead battery resulting from the DCM continually trying to access the cellular network due to deterioration of the internal memory.

Please **note that this is not a safety recall**, and it does not impact the safety of your vehicle.

If your vehicle is operating as expected, you do not need to take your vehicle to a Subaru retailer for repairs.

NOTE: No action is required by you to receive the benefit of this warranty extension. The extension has been automatically applied to your vehicle.

DCM WARRANTY EXTENSION COVERAGE

This extension will cover the costs to install a bypass box for vehicles that are not subscribed to STARLINK telematics or to replace the DCM for vehicles with an active STARLINK subscription. This addresses a potential excessive battery drain if it was determined the DCM was the cause of the dead battery. It also covers the cost of a recharge or replacement of the 12V battery resulting from the DCM failure.

The coverage period extends the Warranty as it applies to the DCM to eight (8) years / one hundred fifty thousand (150,000) miles, whichever comes first from the vehicle Warranty Start Date.

- This extension will cover the replacement of the DCM for vehicles with an "Active" STARLINK subscription if the DCM is confirmed to be the cause of the excessive dark current draw.
- For "Unsubscribed" vehicles, without a STARLINK subscription, with a confirmed excessive dark current draw from the DCM, this extension will cover the installation of a DCM bypass box.
- Customers who received the bypass box have the option to request a replacement DCM once new DCM inventory is available, which is estimated as September 2025. This extension will cover removal of the bypass box and installation of a new DCM. This request must be documented with a Subaru retailer at the time of the initial repair.

Continued...

- Inspections or repairs under this coverage must be completed prior to the expiration of the eight-year (8) period, or before one hundred fifty thousand (150,000) miles, whichever comes first from the vehicle Warranty Start Date.
- Effective from the date of customer notification, **ALL** affected vehicles, regardless of mileage or Warranty Start Date will be covered for a period of one (1) year.
- All inspections and repairs must be completed prior to the expiration of this Warranty extension.

If you have questions about this notice, please contact the DCM Warranty Extension Hotline at 877-551-7149. Additional information can be found online at: subaruclaims.autosolutionteam.com.

REIMBURSEMENT ELIGIBILITY

- You may be eligible for reimbursement if you paid to have your vehicle's DCM replaced to address a dead battery after the expiration of the original New Vehicle Limited Warranty period, but before this announcement of this newly extended warranty period of eight (8) years/one hundred fifty thousand (150,000) miles.
- You must have paid an out-of-pocket expense for a repair that would have been covered had it occurred during the warranty coverage period. This includes any deductible expense or partial reimbursement for repairs.
- If you have been previously reimbursed by SOA or one of its retailers for partial coverage of this repair, only the portion that has not been reimbursed is eligible for reimbursement.
- You are not eligible to recover any repair costs previously reimbursed or paid for by any third-party, including Subaru Added Security, other extended warranty providers, or an authorized Subaru retailer.
- The period of the reimbursement shall be one (1) year from the customer notification of this warranty extension.

TO APPLY FOR REIMBURSEMENT

Please complete the claim form online at subaruclaims.autosolutionteam.com and attach the required documentation listed below:

- Attach a copy of the receipt or invoice for the repair. A copy of the repair invoice or work order showing repair will meet this requirement. The invoice must show your vehicle model, vehicle identification number (VIN), the name and address of the facility that completed the repair, the cost of the repair (parts and labor), and the date the work was completed.
- Attach proof of payment, such as a copy of the canceled check, bank statement, cash receipt, or credit card receipt showing what you paid for the repair.

If you prefer to apply for reimbursement by mail, please send copies of the required documentation listed above to:

Continued...

**Subaru of America Inc.
DCM Warranty Extension
2670 Executive Drive
Indianapolis, IN 46261**

Please allow 45 days for the reimbursement to be processed. Failure to include proper documentation may delay your reimbursement.

Sincerely,

Subaru of America, Inc.

Continued...