



Mack Trucks, Inc.
Greensboro, NC USA

Service Program Trucks

This Service Program replaces service program "Battery Disconnect Switch", PV729-PI0775 (USA52847) dated (4.2012).
Date: 7.2012 Group: 311 No.: 775 Release: 02 Page: 1(6)

Battery Disconnect Switch
CHU

PI0775, Battery Disconnect Switch

(July 2012)

The battery disconnect switch may have been bypassed on some CHU model vehicles, built from 12/1/2009 thru 12/1/2011 with both left hand and right hand battery boxes. The right hand positive cable may have been routed directly to the starter and not to the battery disconnect switch. To check and correct the battery disconnect functionality complete the following procedure.

Note: This bulletin does not apply to MACK Trucks Australia.

Required Parts

Description	Part Number
Cable Ties	980464
Cable Ties	20395795

You must read and understand the precautions and guidelines in Service Information, group 20, "General Safety Practices, Engine" before performing this procedure. If you are not properly trained and certified in this procedure, ask your supervisor for training before you perform it.

Inspection

- 1 Secure the vehicle for service by parking it on a flat level surface, applying the parking brake, chocking the rear wheel, and placing the transmission in neutral."
- 2 Turn the battery disconnect switch OFF.

Note: Make sure vehicle is in neutral and park brakes are set.

- 3 Turn the ignition key to the Crank position
- 4 If the vehicle doesn't crank the testing is complete and no further repair is required. If vehicle cranks or attempts to start then proceed to repair (see page 2).

Repair

- 1 Disconnect all of the positive and negative battery cables from the batteries on the left and right side battery boxes.

- 2 Remove the cutout section located in the center of the rubber floor mat inside the cab.

Note: For vehicles with a manual transmission you will require the removal of the shifter boot first.

- 3 Remove the access panel located in the center of the floor board.

- 4 Locate the positive (+) battery cable routing from the right side box to the starter.

Note: There should only be 1 positive (+) cable from the disconnect switch to the starter.

- 5 Remove the positive (+) battery cable located at the starter solenoid from the right hand battery box.

Reinstall nut and torque to:

Delco Starter 26 ± 1.5 Nm (19.2 ± 1.1 ft-lb)

Melco Starter 25 ± 5 Nm (18 ± 4 ft-lb)

- 6 Remove cable ties as needed to loosen this cable enough to re-route up and over the transmission to the rear stud of the battery disconnect switch.

Note: There will be fold back on this cable from previous install.

- 7 Loosely lay the cable into position beside the other cable as they route up and over the transmission.

- 8 Loosely attach the cable into position on the rear of the disconnect switch with nut removed. This is the same stud on which the left side battery box positive (+) cable is mounted.

Note: Do not tighten at this time.

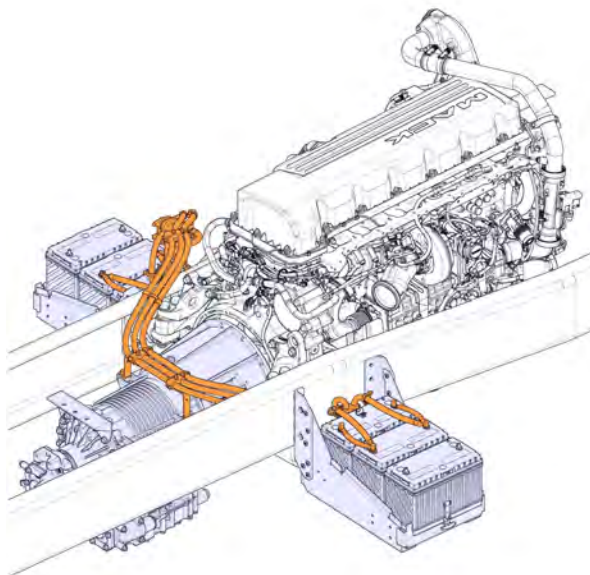

9 Secure the cable at each clamping point with cable ties.

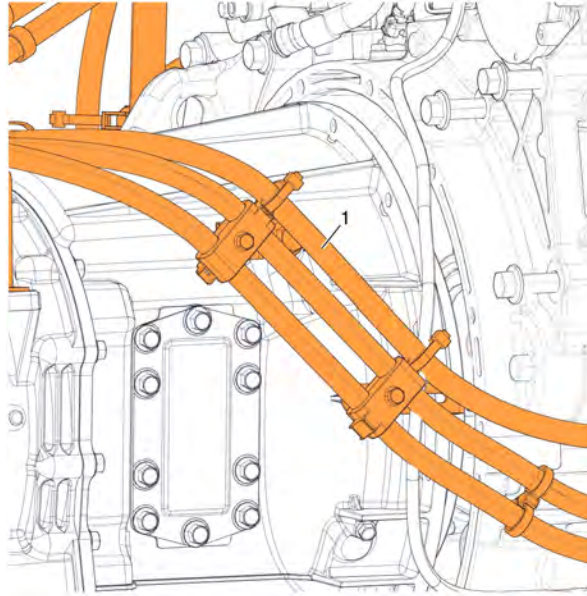

W3072487

1. Cable to be rerouted

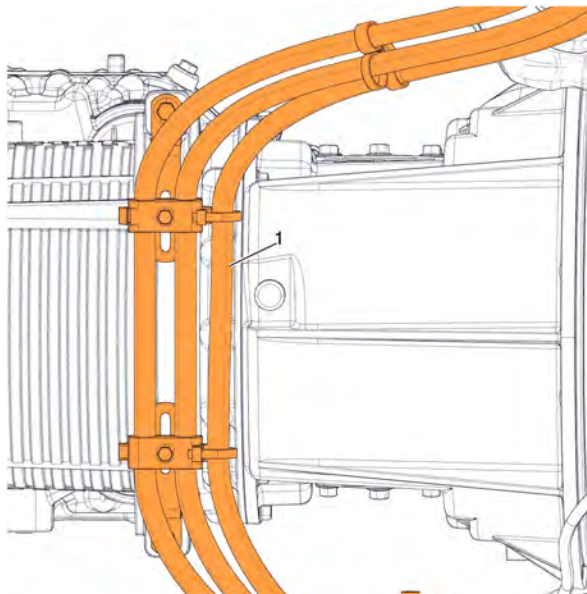

W3072488

1. Cable to be rerouted

- 10 Add a figure-eight style cable tie in between each of the plastic clamps at the fixed mounting position.

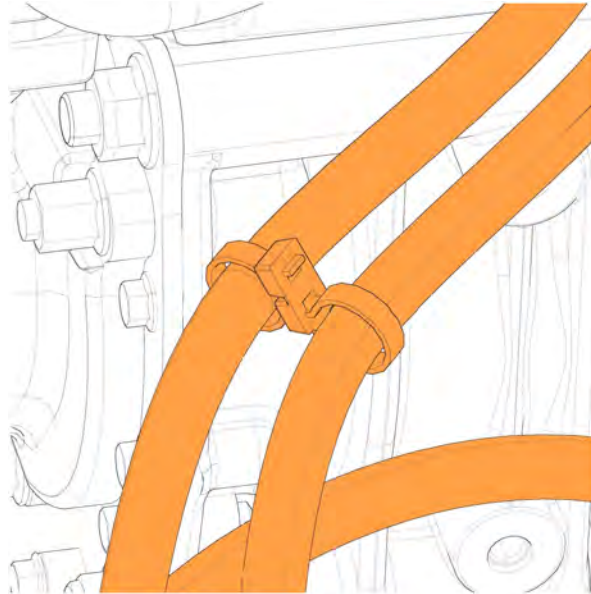

W3072489

- 11 Continue routing and clipping as instructed until the cable has been secured from the disconnect switch to the right side battery box.

Note: Use the figure eight cable ties to isolate potential rub issues that are noticed.

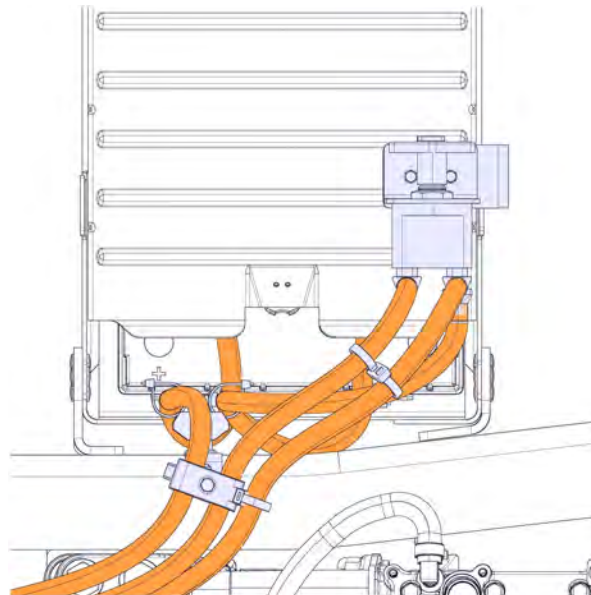

W3072490

12 Torque the rear nut on the disconnect switch.

Torque the nut to: 16.3 ± 1.6 Nm (12 ± 1.2 ft-lb)

13 Install the access panel located in the floor board.

14 Install the rubber floor mat inside the cab.

Note: Install shifter boot if previously removed.

15 Connect all the positive (+) and negative (-) cables previously removed from the batteries on the left and right side battery boxes.

16 With the disconnect switch in the OFF position, try and crank the vehicle. The vehicle should not start. If it does start, recheck that the proper cable was rerouted. Repair if necessary.

17 Turn the disconnect switch ON, check that the vehicle starts properly.

Note: To signify that the campaign has been completed, using a permanent-type marker (such as a Sharpie®) write the campaign number (P10775) and completion date in the spaces provided on the Campaign Completion label located inside the cab as shown in the illustration below. If a label is not already affixed inside the cab, apply a label (part No. TS897) and supply the information as required. Campaign Completion labels are available in packs of 50 and can be ordered by faxing a completed BR313 to Pacesetters Business Services at 610-264-9465.

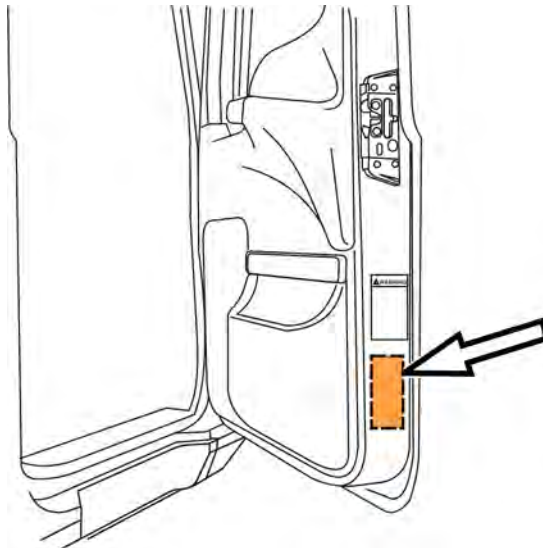

W8034103

Reimbursement

This repair is covered by an authorized Service Program. Reimbursement is obtained through the normal claim handling process.	
Claim Type (used only when uploading from the Dealer Bus. Sys.)	B
Recall Status	
Vehicle inspected, repair not required	1- Inspected OK
Vehicle repaired per instruction	2- Modified per instruction
Labor Code	
Primary Labor Code (includes inspection and take charge)	7211D-ZQ-96 2.0 hours
Inspection (includes take charge)	7211C-ZQ-96 0.4 hours
Causal Part	21875989
Authorization Number	PI0775
Expiration Date	03-APR-13