



**SB-10044322-8678**

Date	Group	No.	Release	Page
5.2012	<b>234</b>	<b>014</b>	<b>01</b>	1(9)

## Fuel Tank Ventilation Filter

CHU, CXU, GU, TD  
MP7, MP8, MP10  
US07, US10

### FSB 234-014, Fuel Tank Ventilation Filter

(May 2012)

MACK Trucks is introducing a fuel tank ventilation filter kit to prevent erosion of the engine fuel injector tips on CHU, CXU, GU, and TD truck models. The fuel tank ventilation filter is primarily designed for use in harsh, abrasive and dirty environments. The fuel tank ventilation filter is added to the fuel tank vent lines and mounted on the stanchion exhaust bracket at the right side of the truck. For single or dual tank applications, the vent-lines will run from the tank vent fittings to the fuel tank ventilation filter. Stand-off brackets and cable ties will be used to secure the vent-lines. Rubber tubing over the vent-lines will be used to prevent chafing by the rear deck plate/frame.

**Note:** To ensure the effectiveness of the fuel tank ventilation filter system, the fuel tank ventilation filter must be changed at the same interval as the engine air filter.

**Note:** This bulletin does not apply to MACK Trucks Australia.

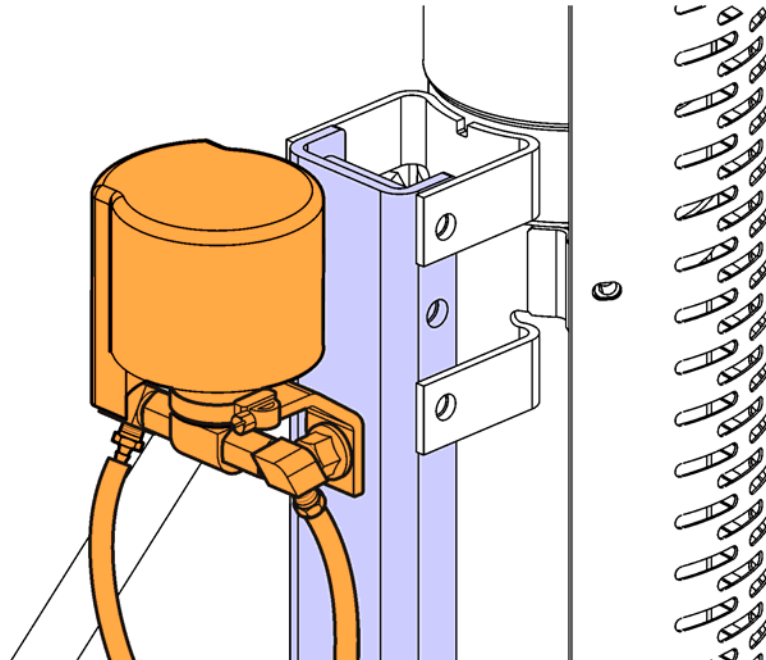

W2069488

## Required Parts

Fuel Tank Ventilation Kit 21882780			
Item	QTY	Part Number	Description
1	1	85132334	Rubber Hose, 4572 mm (180 in)
2	2	21776035	Hose Nipple
3	2	85103103	Elbow
4	2	982710	Reduction Nipple
5	1	984855	Flange Screw (M14)
6	1	** 20593078	Clamp (Mount with existing hardware)
7	1	** 984942	Clamp (Mount with existing hardware)
8	1	992328	Flange Nut (M14)
9	1	** 192489	Clamp (Mount with M10 Hardware)
10	1	** 1543499	Flange Nut (M10)
11	1	** 984753	Flange Screw (M10)
12	1	20455696	Manifold (Mount with M14 Hardware)
13	1	21882786	Air Cleaner
14	16	** 948211	Cable Tie
15	6	** 20885496	Retainer
16	16	** 980464	Cable Tie
17	1	991061	Plug
18	1	85132335	Tube, 5182 mm (204 in)
19	2	21807860	Label, Fuel Tank Filter

**Note:** \*\* Due to various tank and deck plate configurations, some routing and clipping hardware may not be used.

Replacement Fuel Filter (Not Included in Kit)			
Item	QTY	Part Number	Description
1	1	21763342	Fuel Filter

## Procedure

You must read and understand the precautions and guidelines in Service Information, group 20, "General Safety Practices, Engine" before performing this procedure. If you are not properly trained and certified in this procedure, ask your supervisor for training before you perform it.



### DANGER

Do not attempt to repair or service this vehicle without having sufficient training, the correct service literature and the proper tools. Failure to follow this could make the vehicle unsafe and lead to serious personal injury or death.



### CAUTION

Possible damage to electronic components. Turn the vehicle ignition switch OFF before disconnecting or connecting any electronic components. Failure to de-energize circuits may result in permanent damage to electronic components.

- 1 Disconnect all cables from the negative (ground) battery terminals to prevent personal injury from electrical shock and prevent damage to electrical components.
- 2 Install filter on manifold, install fittings (with Thread Sealant) on manifold in the correct orientation, and tighten fittings.

**Note:** Orient fittings in a downward direction to enable moisture to drain from vent-lines.

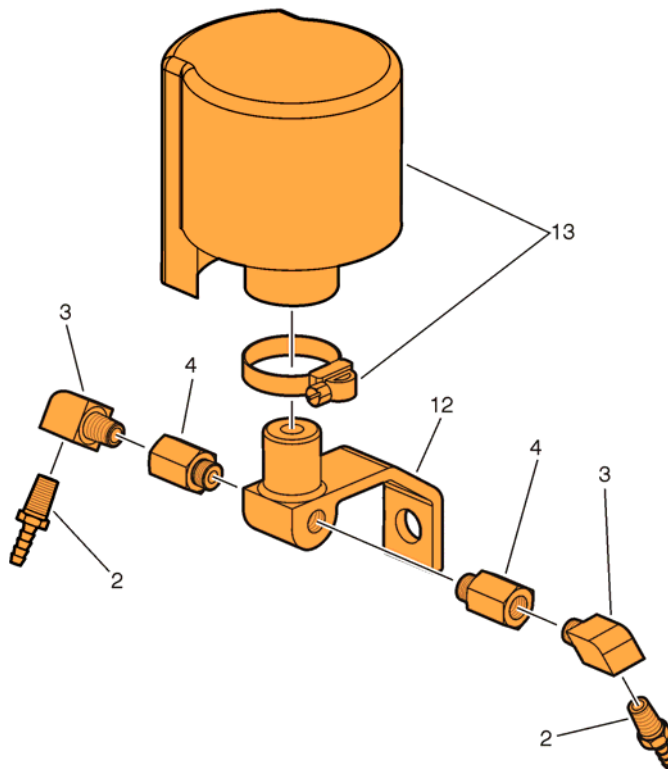

- 3 Install manifold and filter on exhaust stack bracket and tighten fastener to  $140 \pm 25$  Nm ( $103 \pm 18$  ft-lb).

**Note:** If fastener does not fit through hole in the exhaust stack support bracket shown below, drill out hole to accommodate the 14.0 mm (0.5 in) fastener (item 5).

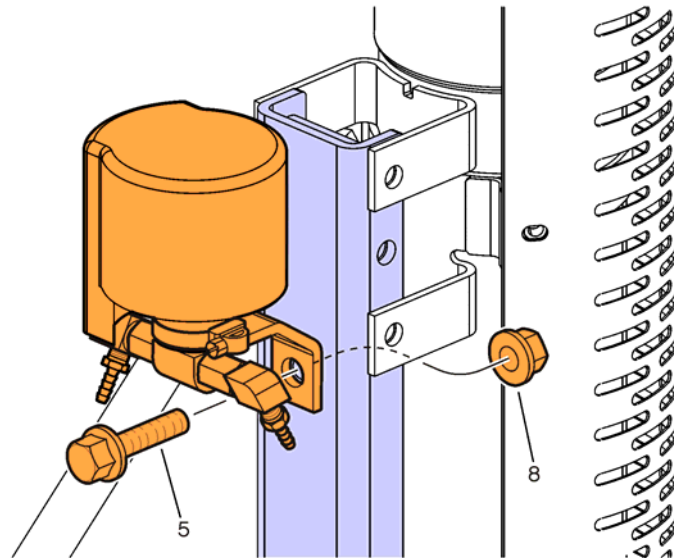

W2069490

- 4 Cut any cable ties securing wiring to line (Right Side). Remove existing vent-lines and discard (Right Side).
- 5 Install cable ties on wiring that was cut during removal of existing vent-line.
- 6 Reposition vent fittings on fuel tank as shown in figure below.

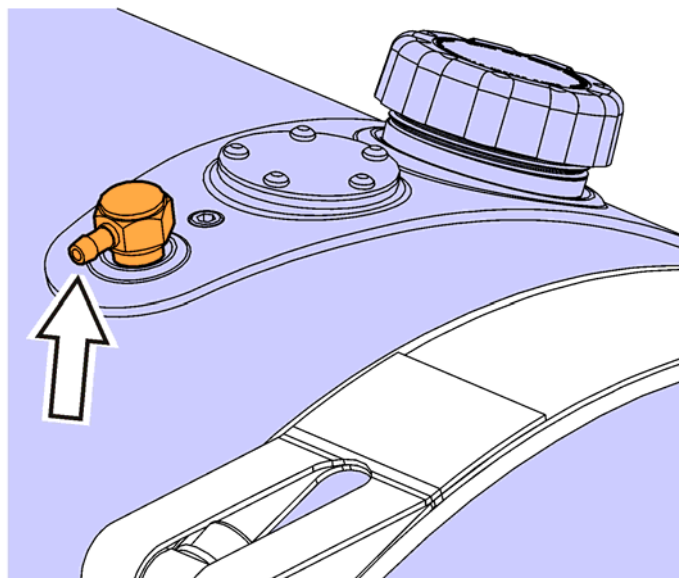

W2069491

- 7 Install protective rubber tubing over vent tubing in areas where chafing may occur.

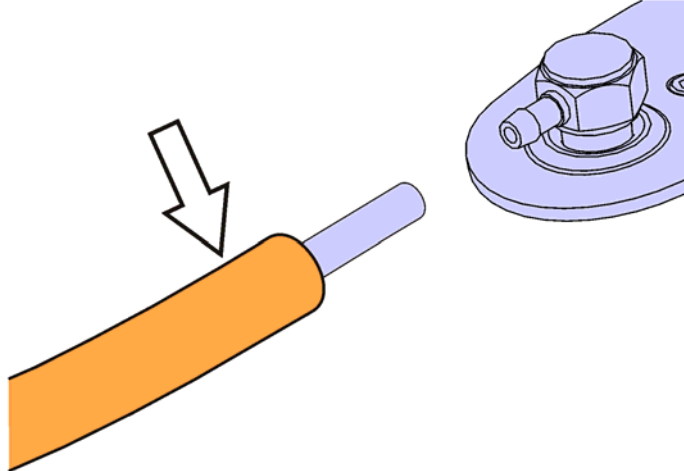

W2069492

- 8 Route new vent-line from fuel tank to filter (Right Side), and cut to length.

**Note:** Vent-lines must be routed without loops. Loops in the vent-lines will trap moisture and contaminate the fuel.

- 9 Install line on filter manifold (Right Side).

**Note:** Install plug part number 991061 in the open port of the manifold for single tank applications as shown in the figure below.

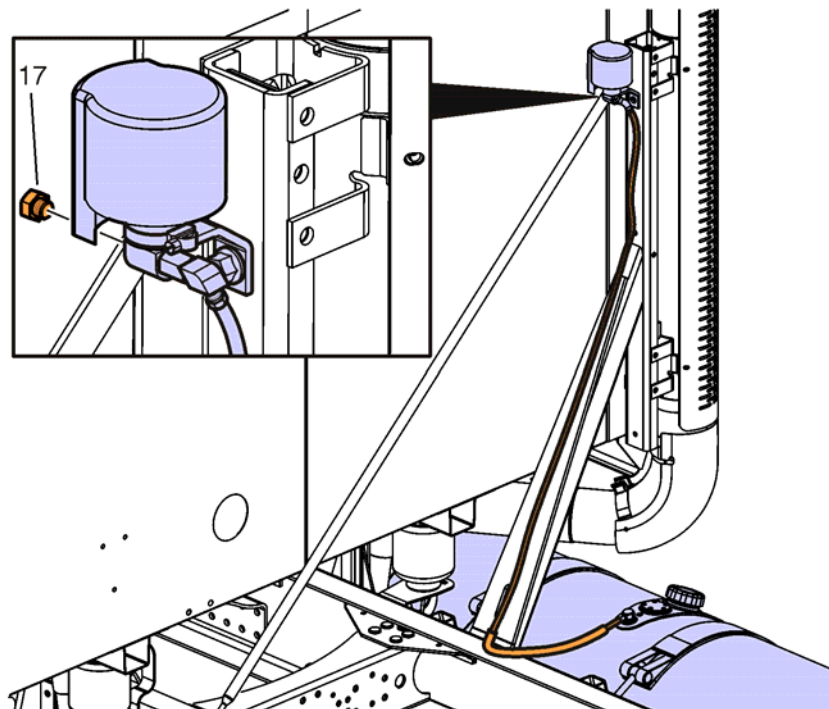

W2069493

10 Use the appropriate cable ties and clamps to secure and prevent chafing or damage to the vent line.

**Note:** For single tank configurations, skip to step 18. For dual tank configurations, continue onto step 11.

11 Cut any cable ties securing wiring to line (Left Side). Remove existing vent-lines and discard (Left Side).

12 Install cable ties on wiring that was cut during removal of existing vent-line.

13 Reposition vent fittings on fuel tank as shown in figure below.

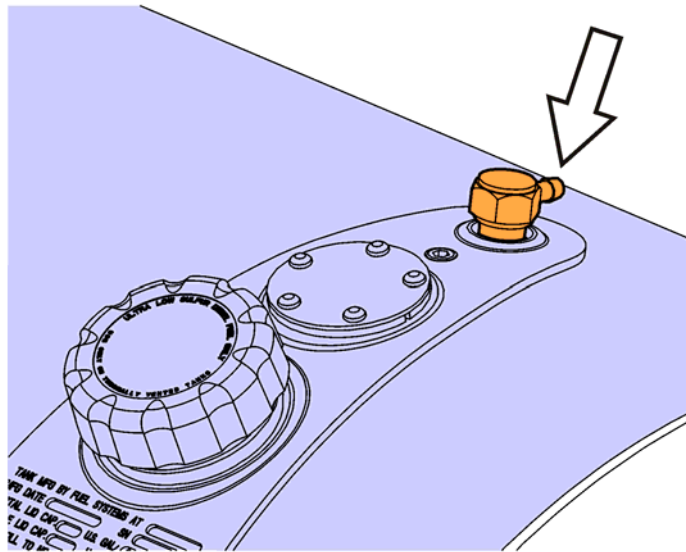

W2069494

14 Install protective rubber tubing over vent tubing in areas where chafing may occur.

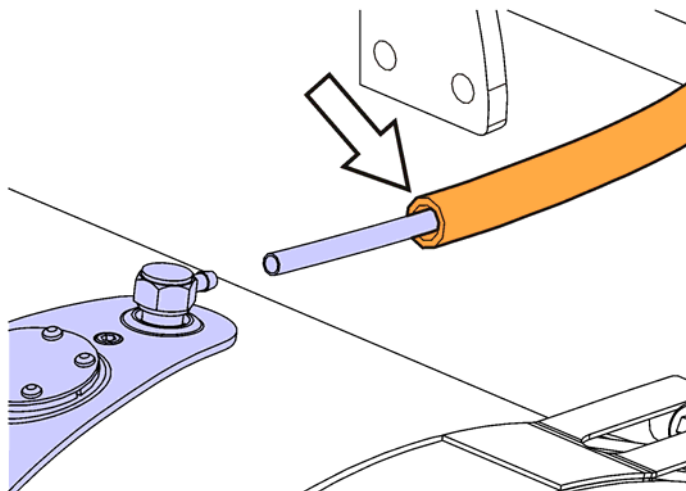

W2069495

- 15 Route new vent-line from the fuel tank, under the deck plate, and to the filter (Left Side).
- 16 Install line on filter manifold (Left Side).

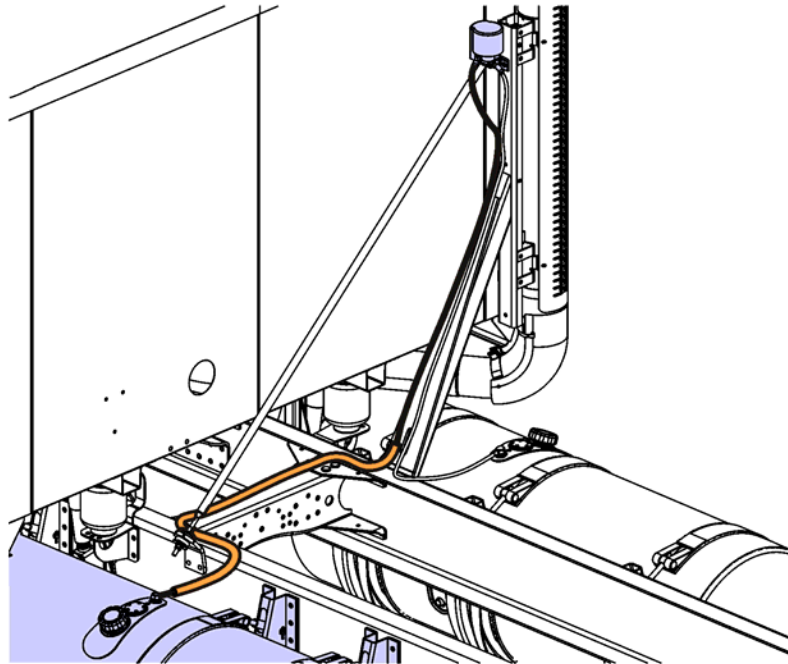

W2069496

- 17 Use the appropriate cable ties and clamps to secure and prevent chafing or damage to the vent line.

**Note:** The appropriate part numbers used for routing and clipping the vent-line is identified by double asterisks in the table on page 1.

- 18 Install replacement engine fuel filter, part number 21763342.

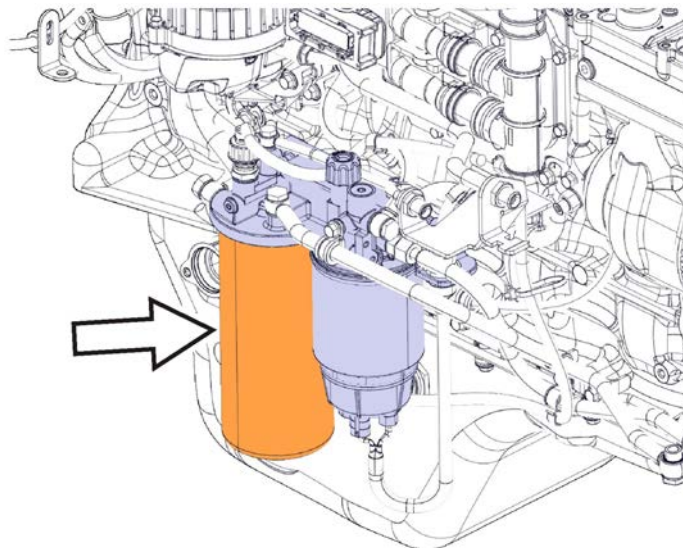

W2069497

19 Attach fuel tank ventilation filter labels (21807860) as shown in the figures below.

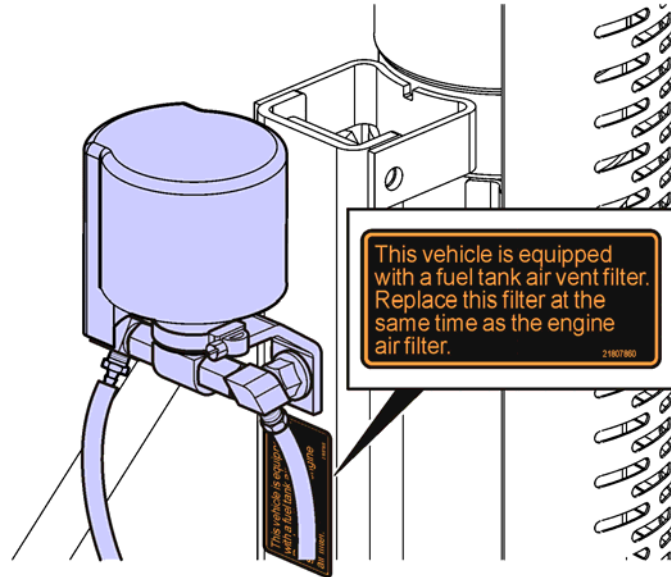

W2069498

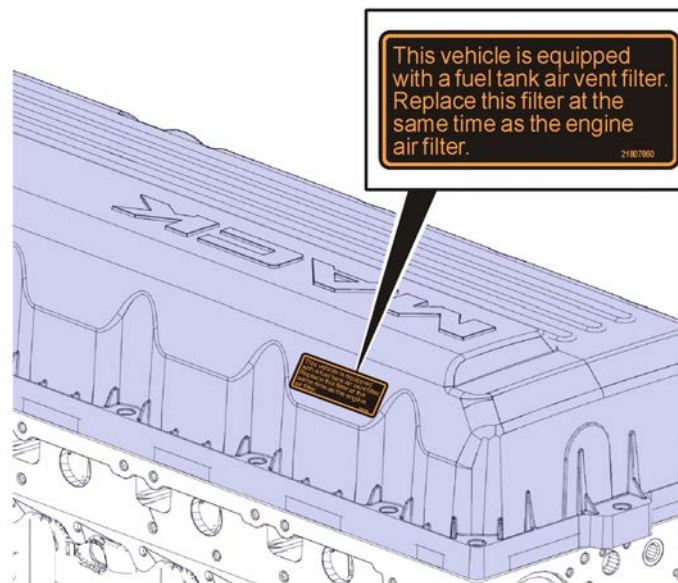

W2069545

20 Reconnect all previously removed cables to the negative (ground) battery terminals and remove wheel chocks.



**Reimbursement**

<b>This repair may be eligible for reimbursement if a product failure was experienced within time and mileage limits of the applicable Warranty coverage. Reimbursement is obtained via the normal claim handling process.</b>	
<b>Claim Type (used only when uploading from the Dealer Bus. Sys.)</b>	W
<b>Labor Code</b>	
Primary Labor Code Dual Tank Configuration	2314D-00-80 1.1 hrs.
Primary Labor Code Single Tank Configuration	2314C-01-80 1.0 hrs.
<b>Causal Part</b>	40QE2187

MACK Trucks Inc. engages in a continuous program of testing and evaluating to provide the best possible product. MACK Trucks Inc., however, is not committed to, or liable for updating existing chassis.