

This Field Service Bulletin replaces bulletin, "SP255-022, Connector Relocation", PV729-SP255-022_V (USA52753) dated (04/2012).

Date	Group	No.	Release	Page
5.2012	255	022	02	1(6)

Engine VGT Actuator and TSS Sensor Connector, Relocation VN, VHD, VAH D13H

SP 255-022, Engine VGT Actuator and TSS Sensor Connector Relocation

(May 2012)

A new campaign is available to prevent engine diagnostic trouble codes (DTCs) and missing signal from the Engine Variable Geometry Turbocharger Actuator (Engine VGT Actuator) on VOLVO D13 US2010 engines with a Mechanical transmission. This condition is caused by fretting of the connector pins in the engine VGT actuator connector. Relocation of the engine VGT actuator connector and a new mounting arrangement has been developed to eliminate this condition. See the table below for the list of parts required for this campaign.

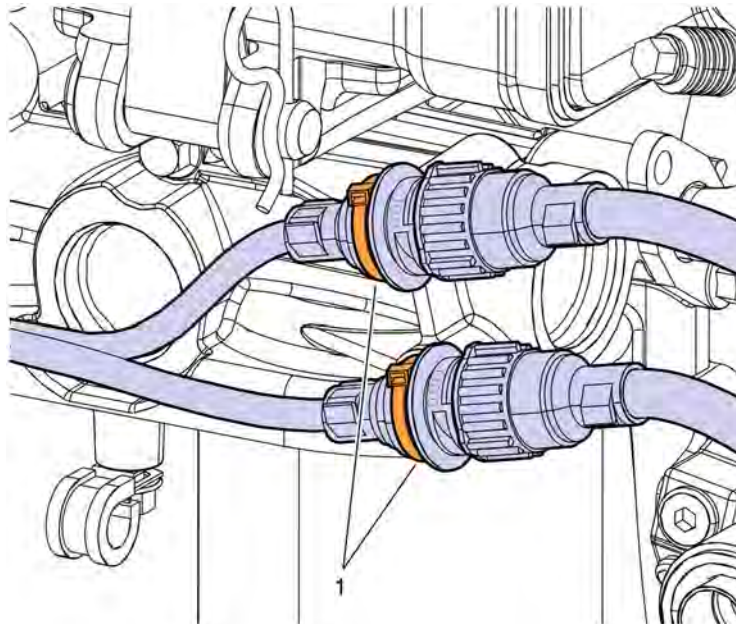

W2072567

Required Parts

Mechanical Transmission Parts List			
Item #	QTY	Part Number	Description
1	2	980881	Push-In Cable Tie

Relocation Procedures for the Mechanical Transmission

You must read and understand the precautions and guidelines in Service Information, group 20, "General Safety Practices, Engine" before performing this procedure. If you are not properly trained and certified in this procedure, ask your supervisor for training before you perform it.

NOTE: Information is subject to change without notice. Illustrations are used for reference only and can differ slightly from the actual vehicle being serviced. However, key components addressed in this information are represented as accurately as possible.

Mechanical Transmission

- 1 Apply parking brake and place shift lever in neutral.
- 2 Raise hood.
- 3 Disconnect all cables from the negative (ground) battery terminals to prevent personal injury from electrical shock and prevent damage to electrical components.
- 4 Disconnect the engine VGT actuator and Turbine Shaft Speed (TSS) Sensor harnesses.

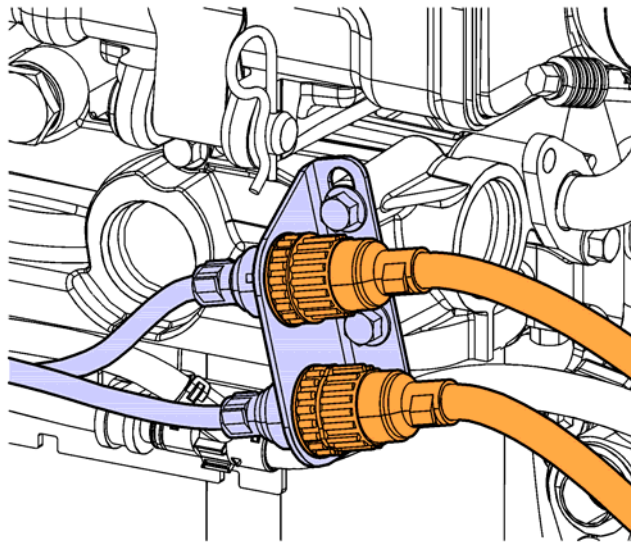

W2072330

- 5 Remove the engine VGT actuator and TSS sensor connectors from the mounting bracket.

Note: Discard the attachment ring/nut (Item 1).

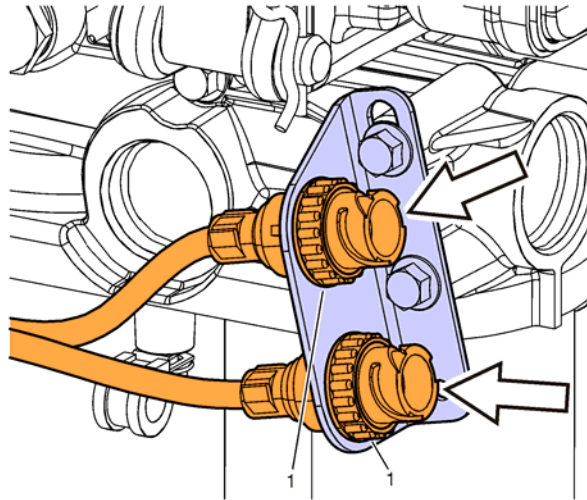

W2072331

- 6 Remove the connector mounting bracket from oil filter housing.

Note: Discard the mounting bracket.

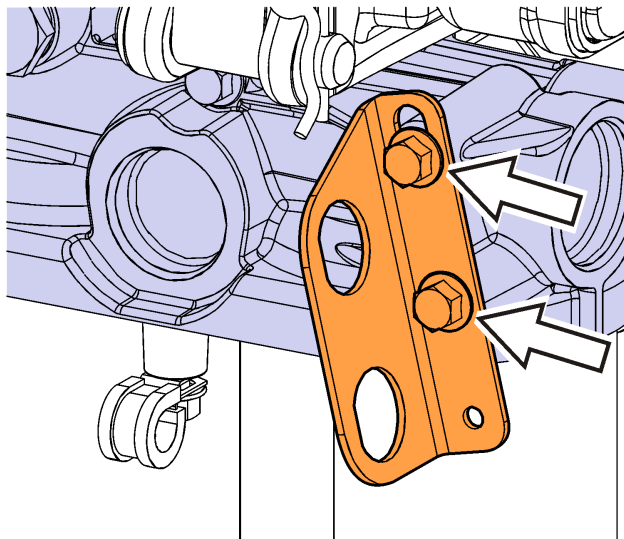

W2072332

- 7 Inspect connectors for green/brown dust on the pins or sockets.

Note: If green/brown dust is present in the areas highlighted in the figure below, clean the male and female engine VGT actuator and TSS sensor connectors with approved electrical solvent. Allow the connectors to thoroughly dry before assembly.

Note: If the Engine VGT Actuator Connector pins show signs of wear, replace the pins per "Engine VGT Actuator Connector Pin, Replacement" Field Service Bulletin PV729-FSB255-024_V (USA53614).

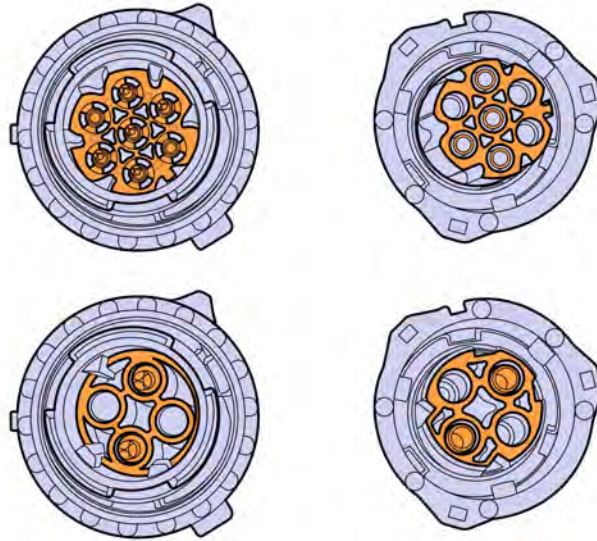

W2072325

- 8 Install the push-in cable ties (part number 980881) into the M8 threaded holes in the oil filter housing.

Note: Ensure the push-in cable tie flanges are tightly secured against the M8 threaded holes in the oil filter housing.

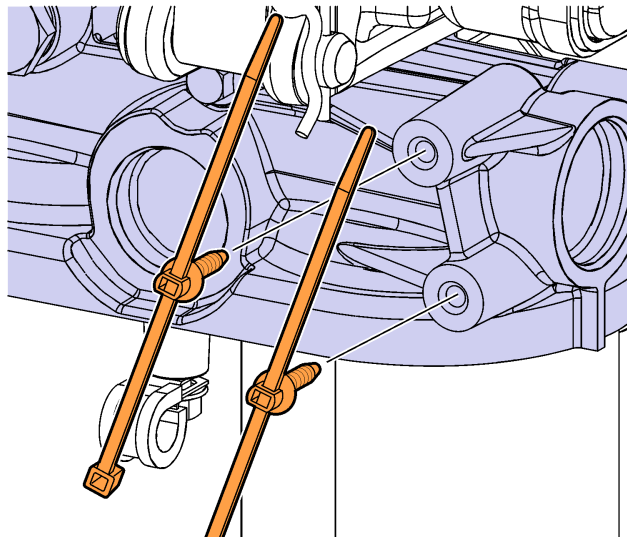

W2072333

9 Connect and lock the engine VGT actuator and TSS sensor connectors together.

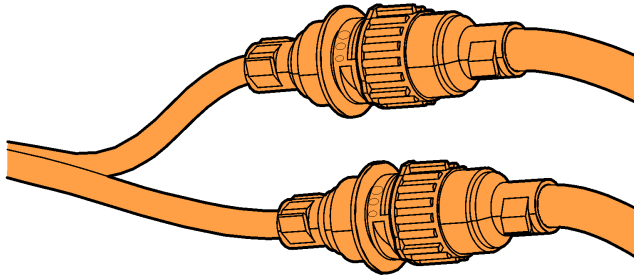

W2072334

10 Secure both connectors with the push-in cable ties.

Note: Ensure the cable tie is in the end groove between connector flange and back shell as shown in figure below.

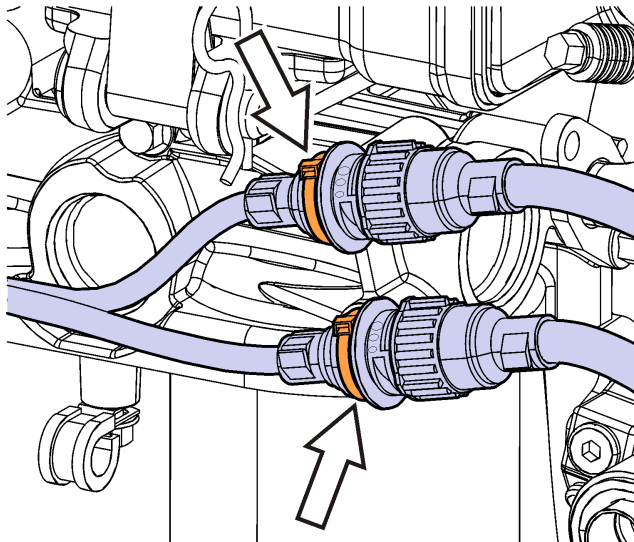

W2072335

11 Reconnect all previously removed cables to the negative (ground) battery terminals.

12 Lower hood.

Reimbursement

This repair is covered by an authorized Service Program. Reimbursement is obtained through the normal claim handling process.	
Claim Type (used only when uploading from the Dealer Bus. Sys.)	B
Recall Status	
Vehicle inspected, repair not required	1- Inspected OK
Vehicle repaired per instruction	2- Modified per instruction
Labor Code	
Primary Labor Code	25530-0-02 0.3 hr.
Time to take charge and determine campaign status	17003-0-01 0.3 hr.
Causal Part	21551428
Authorization Number	SP255022
Expiration Date	16 MAY 13

Note: Take Charge Time is not included in the Labor Code for this operation. Take charge may be eligible but can only be used once per repair visit. If vehicle is having other warranty repairs performed, take charge should be charged to the warranty repair, otherwise take charge can be charged to this service program.