

Brake S-Cam Tube Lubrication Interval Change

FLA COE
 FLB COE
 FLD Conventional
 Business Class
 FLC 112 Conventional

> Century Class Conventional
 Argosy COE
 Cargo
 > Columbia

> Coronado
 Business Class M2
 > Cascadia
 108SD/114SD

Freightliner
 Service Bulletin

General Information

To ensure optimum service life and trouble-free operation, the recommended maintenance interval for lubricating Meritor S-cam brake tubes on Century Class, Columbia, Cascadia and Coronado over-the-road vehicles is changed from the M2 to the M1 maintenance interval. All S-cam tubes should be lubricated at 25,000 mile, regardless of brake brand. Fully lubricated brake S-cam tubes ensure that moisture and contaminants do not enter the cam tube, potentially causing corrosion, slow return, and seal damage.

IMPORTANT: When lubricating the S-cam tube, the best indicator of a complete lubrication of the S-cam tube is to observe a grease purge from the inboard S-cam tube seal. See [Fig. 1](#). Grease purge should be evident upon delivery of new vehicles after pre-delivery inspection (PDI) as well as after each prescribed maintenance interval. If there is no evidence of a grease purge, grease should be applied per maintenance manual instructions until grease purges at the inboard seal.

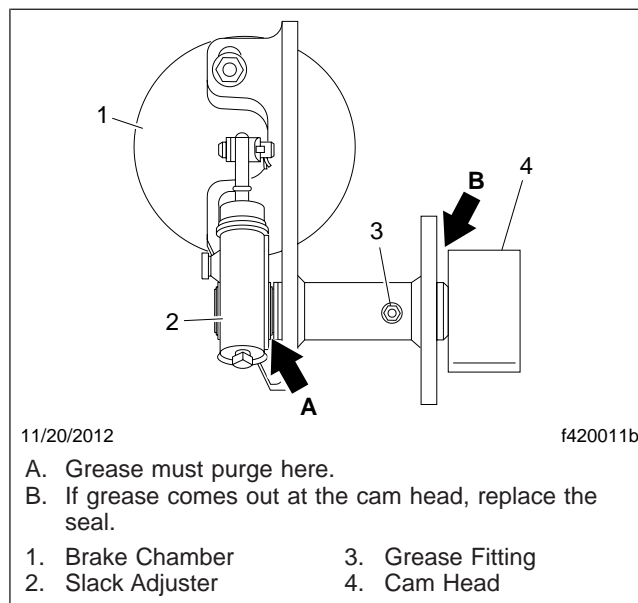

Fig. 1, S-cam Tube Lubrication

Warranty

This bulletin is informational only. Warranty does not apply.