



Mack Trucks, Inc.
Greensboro, NC USA

Field Service Bulletin Trucks

This Field Service Bulletin replaces bulletin, "Hose, Engine Oil Fill Tube", PV729-FSB221-009_M (USA57868) dated (02/2013).

Date	Group	No.	Release	Page
5.2013	221	009	02	1(5)

SB-10051567-1898

Hose, Engine Oil Fill Tube
LEU, MRU
Cummins ISL-G

FSB 221-009, Hose, Engine Oil Fill Tube

(May 2013)

Certain Mack MRU and LEU trucks equipped with Cummins ISL-G engines built before February 11, 2013 may exhibit minor oil seepage from the engine oil filler tube hose or display stress cracks in the hose. This condition is caused by improper installation of the engine oil fill tube hose during assembly. Trucks built after February 11, 2013 have engine oil fill tube hoses of the same construction which include index marks to aid in proper assembly. Using the part numbers listed in the table below, replace the engine oil fill tube hose and clamps to repair minor oil seepage or stress cracks in the existing hose. Follow the installation instructions contained in this bulletin for proper clocking/indexing of the new hose.

Note: This bulletin does not apply to MACK Trucks Australia.

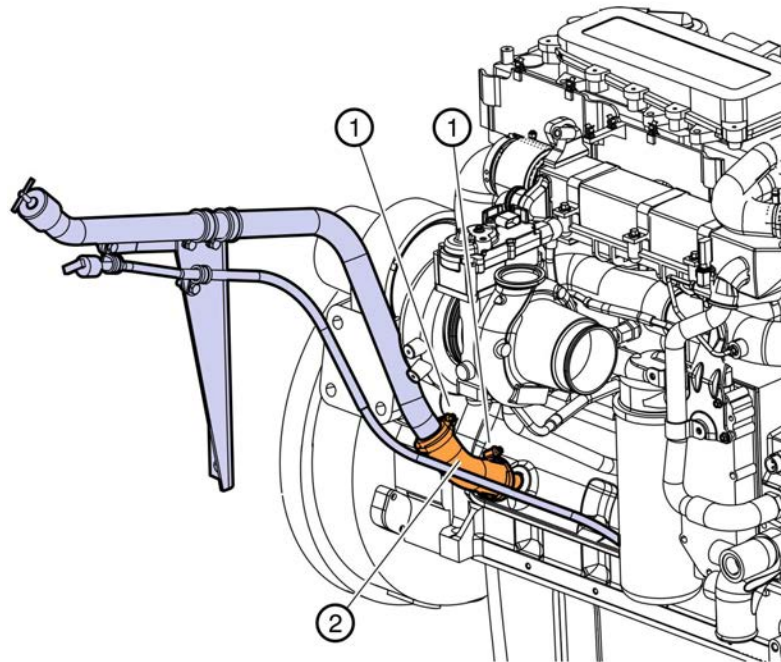

W2079924

Required Parts

Engine Oil Fill Tube Hose Replacement Parts			
Item	Description	Part Number	Qty
1	Hose, Engine Oil Fill Tube	25496740	1
2	Hose Clamp	984997	2

Procedure

You must read and understand the precautions and guidelines in Service Information, group 20, "General Safety Practices, Engines" before performing this procedure. If you are not properly trained and certified in this procedure, ask your supervisor for training before you perform it.



DANGER

Do not attempt to repair or service this vehicle without having sufficient training, the correct service literature and the proper tools. Failure to follow this could make the vehicle unsafe and lead to serious personal injury or death.

- 1 Secure the vehicle for service by parking it on a flat level surface, apply the parking brake, chock the rear wheels, and place the transmission in neutral or park.
- 2 Disconnect all battery cables from the negative (ground) battery terminals to prevent personal injury from electrical shock and prevent damage to electrical components.
- 3 Secure any loose items in the cab to prevent damage to the dash or windshield when the cab is tilted. Unlock the pump and tilt the cab forward.
- 4 Remove P-clamp fasteners securing oil fill tube to frame bracket.

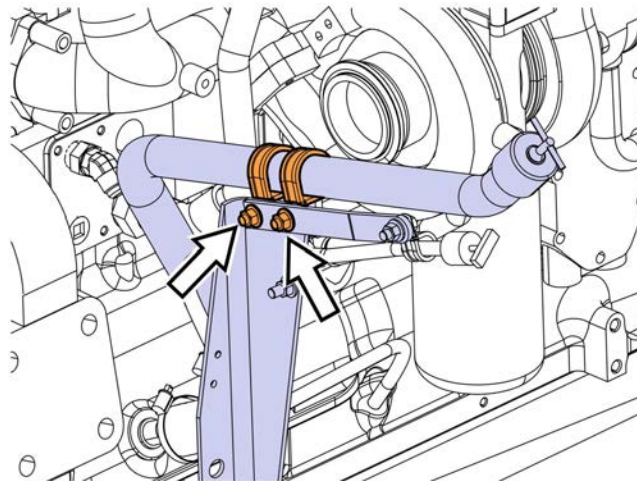

W2079925

- 5 Loosen both hose clamps securing hose to the tube and the neck on the oil pan.

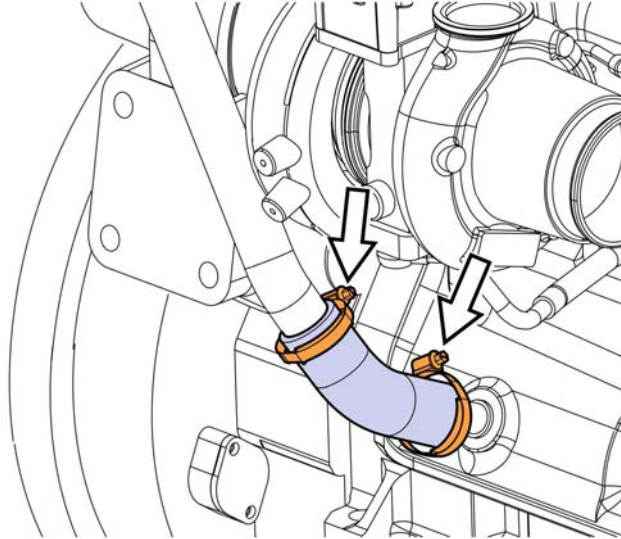

W2079926

- 6 Remove the existing engine oil fill tube hose and clamps.

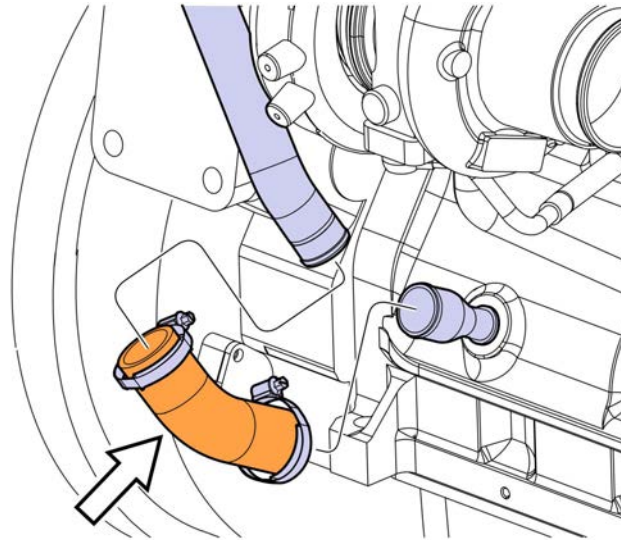

W2079927

- 7 Position the new hose and clamps on the filler tube.

Note: Do not install the hose onto the engine connection past where the taper begins on the tube. The other end of the hose should extend about 30 mm (1.2 in) on the chassis filler tube for proper installation.

Note: Do not tighten clamps at this time.

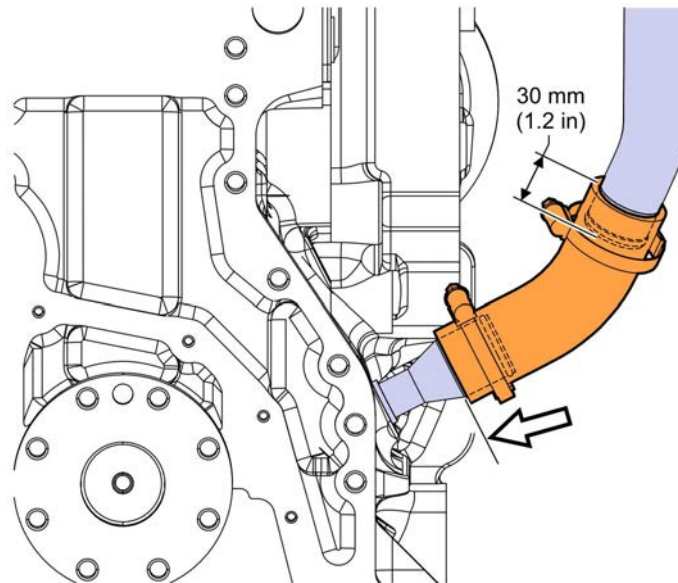

W2080034

- 8 Loosely connect the oil filler tube P-clamps to the frame mounted bracket, verify that the lower filler hose is in a relaxed position and aligned with the installation clocking of the upper tube.

Note: Adjust the lower engine oil fill tube hose to prevent twisting load or excessive bending of the hose.

- 9 Tighten P-clamp fasteners to 24 ± 5 Nm (18 ± 4 ft-lb).

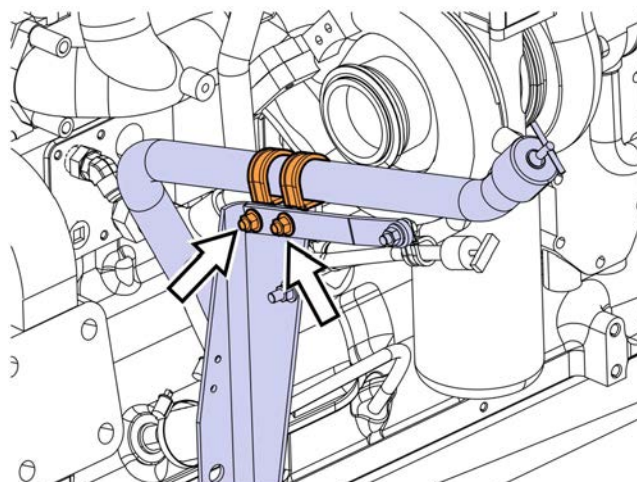

W2079925

- 10 Ensure the hose is aligned properly while in a relaxed position and before securing hose clamps.
- 11 Tighten hose clamps to 3 + 0.5 Nm (27 + 5 in-lb).

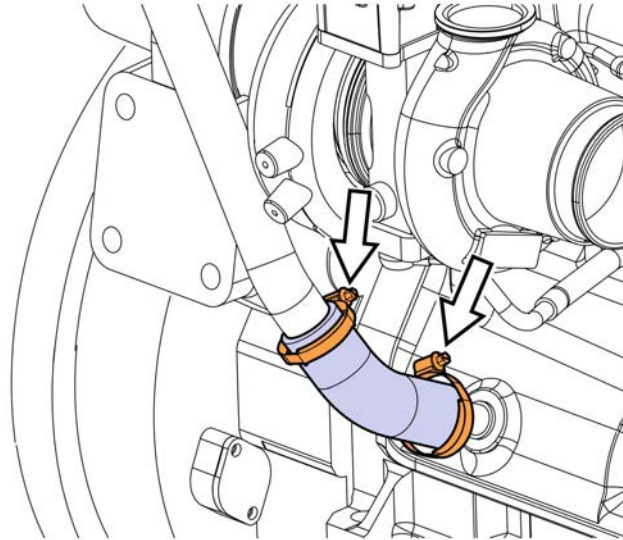

W2079926

- 12 Reconnect all previously removed cables to the negative (ground) battery terminals.
- 13 Lower the cab to the closed and locked position.
- 14 Start engine, check for proper operation and leaks.
- 15 Remove wheel chocks.

Reimbursement

This repair may be eligible for reimbursement if a product failure was experienced within time and mileage limits of the applicable Warranty coverage. Reimbursement is obtained via the normal claim handling process.	
Claim Type (used only when uploading from the Dealer Bus. Sys.)	01
Labor Code	
Primary Labor Code	2192D-CT-80 0.3 hrs.
Causal Part	25496740

MACK Trucks North America engages in a continuous program of testing and evaluating to provide the best possible product. MACK Trucks North America, however, is not committed to, or liable for updating existing chassis.