



Mack Trucks, Inc.
Greensboro, NC USA

Field Service Bulletin Trucks

Date	Group	No.	Release	Page
5.2013	371	045	01	1(4)

SB-10052257-7537

Battery Starter Lug Failure
CXU, GU

FSB 371-045, Battery Cable Lug, Failure

(May 2013)

Certain vehicles built from January 1, 2010 to May 28, 2013 with a MP7 engine may experience cracking or breaking of the 90 degree positive battery cable lug at the starter solenoid stud. In some cases, the lug is bent during assembly, and along with engine vibration may cause the terminal to weaken and fail over time.

To support the cable and eliminate this failure, follow the procedure below:

Required Parts

Quantity	Part Number	Description
1	22130041	Bracket
1	21542477	Cable Tie
1	22166540	Saddle
1	990939	Nut
1	994785	Socket Screw

You must read and understand the precautions and guidelines in Service Information, Function Group 30, "General Safety Practices, Electrical and Electronics" before performing this procedure. If you are not properly trained and certified in this procedure, ask your supervisor for training before you perform it.

Repair

- 1 Secure the vehicle for service by parking it on a flat level surface, applying the parking brake, chocking the rear wheel, and placing the transmission in neutral.
- 2 Disconnect all cables from the negative (ground) battery terminals to prevent personal injury from electrical shock and prevent damage to electrical components.
- 3 Remove the fastener from the heat shield bracket.

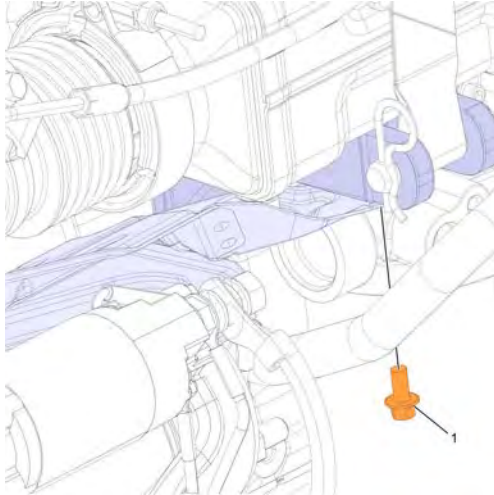

W2080360

1. Screw

- 4 Preassemble the bracket and the saddle.

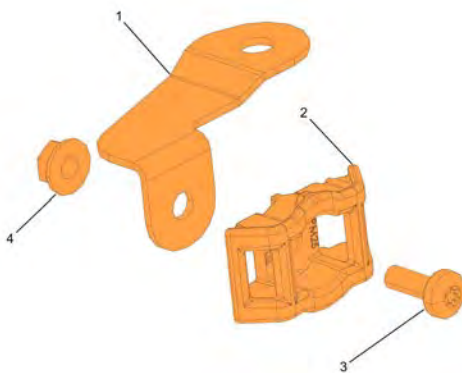

W2080361

- 1 Bracket
- 2 Saddle
- 3 Socket Screw
4. Nut

- 5 Install the bracket onto the vehicle and secure.

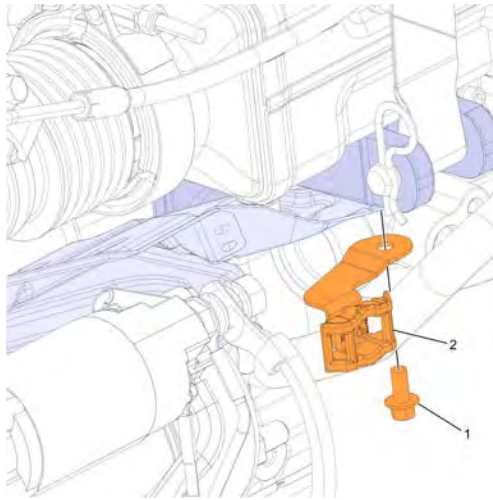

W2080362

1. Socket Screw
2. Saddle

- 6 Install the cable tie around the saddle and the positive battery cable going to the starter solenoid.

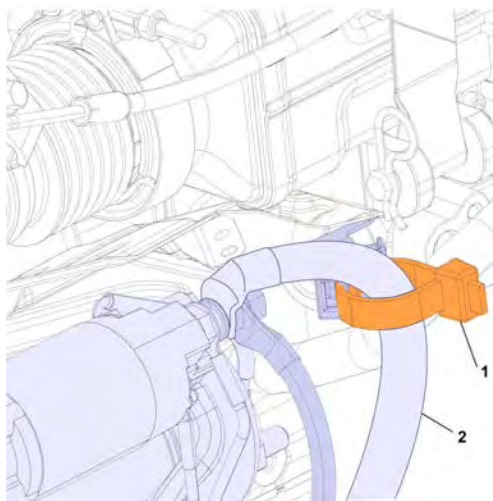

W2080364

1. Cable Tie
2. Positive Battery Cable

Note: Battery cable may need to be loosened/retightened from back of starter solenoid in order to reach the saddle. Tighten to 26 ± 1.5 Nm (19.2 ± 1.1 ft lb).

- 7 Install all the previously removed cables to the negative (ground) battery terminals.

Reimbursement

This repair may be eligible for reimbursement if a product failure was experienced within time and mileage limits of the applicable Warranty coverage. Reimbursement is obtained via the normal claim handling process.	
Claim Type (used only when uploading from the Dealer Bus. Sys.)	01
Labor Code	
Primary Labor Code	7213C-36-80 0.3 hrs.
Causal Part	21266738 21266739

Mack Trucks, Inc. engages in a comprehensive program of testing and evaluating to provide the best possible product. Mack Trucks, Inc. however, is not committed to, or liable for updating existing vehicles.