



Date	Group	No.	Release	Page
6.2013	221	010	01	1(5)

Diagnostic Trouble Codes (DTC's), Low Oil Pressure (SPN 100 FMI 1)
CXU, GU, LEU, MRU
MP7 EPA2010

FSB 221-010, Diagnostic Trouble Codes (DTCs), Low Oil Pressure (SPN 100 FMI 1)

(June 2013)

Information

During long hard pull conditions, Diagnostic Trouble Codes (DTC's) SPN 100 FMI 1 can log on certain CXU, GU, LEU, and MRU MACK Trucks with MP7 EPA2010 engines. If a SPN 100 FMI 1 occurs during the conditions described in this bulletin, with or without an engine shut down lamp, follow Guided Diagnostics (GD) for fault tracing.

Follow GD fault tracing and verify the oil pressure readings with a manual gauge at various engine revolutions per minute (RPMs). After verifying all checks are within specification, the issue is still present, and there are no obvious signs of oil dilution, replace the pressure reduction valves as follows:

Note: Drain all engine oil into a clean container for reuse. Do not reuse engine oil if it is not reusable or the engine is due for normal oil change service.

Note: This bulletin does not apply to MACK Trucks Australia.

Required Parts

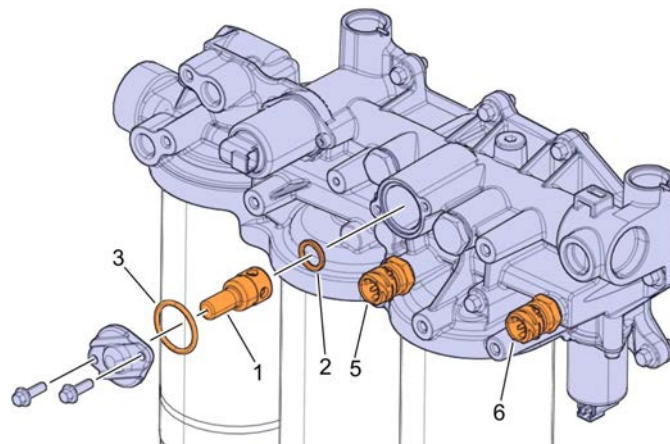

W2082018

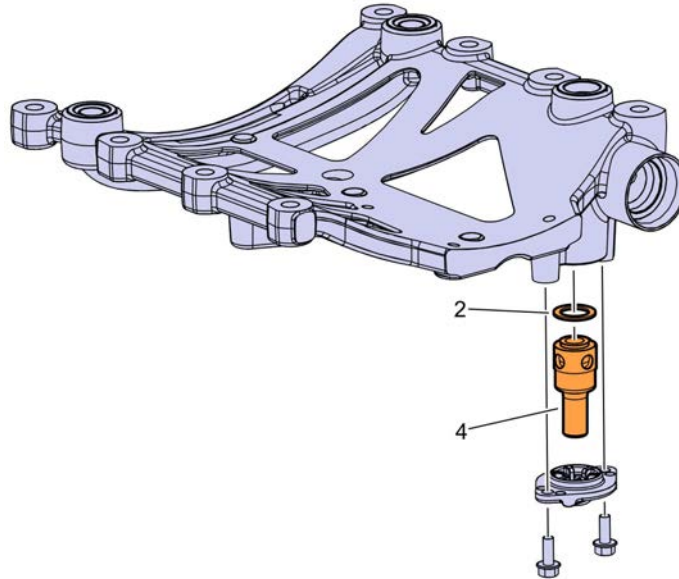

W2082019

Required Parts			
Item #	Part Number	Description	QTY
1	22192217	Pressure Reduction (Regulating) Valve (Blue Mark)	1
2	469846	O-Ring, Internal	2
3	949659	O-Ring, Cover	1
4	22188378	Pressure Reduction (Relief) Valve (Lilac Mark)	1
5	21634021	Engine Piston Cooling Oil pressure Sensor	1
6	21634021	Engine Oil Pressure (EOP) Sensor	1

Procedure

You must read and understand the precautions and guidelines in Service Information, Function Group 2, "General Safety Practices, Engine" before performing this procedure. If you are not properly trained and certified in this procedure, ask your supervisor for training before you perform it.

DANGER

Do not attempt to repair or service this vehicle without having sufficient training, the correct service literature and the proper tools. Failure to follow this could make the vehicle unsafe and lead to serious personal injury or death.

- 1 Secure the vehicle for service by parking it on a flat level surface, applying the parking brake, chocking the rear wheels, and placing the transmission in neutral or park.

- 2 Disconnect all battery cables from the negative (ground) battery terminals to prevent personal injury from electrical shock and prevent damage to electrical components.
- 3 Remove and replace the oil pressure reduction valve with pressure reduction (regulating) valve part number 22192217, replace the internal o-ring with part number (469846), and replace cover o-ring with part number (949659) in the oil filter housing. Tighten cover fasteners to 10 ± 2 Nm (88 ± 17 in-lbs).

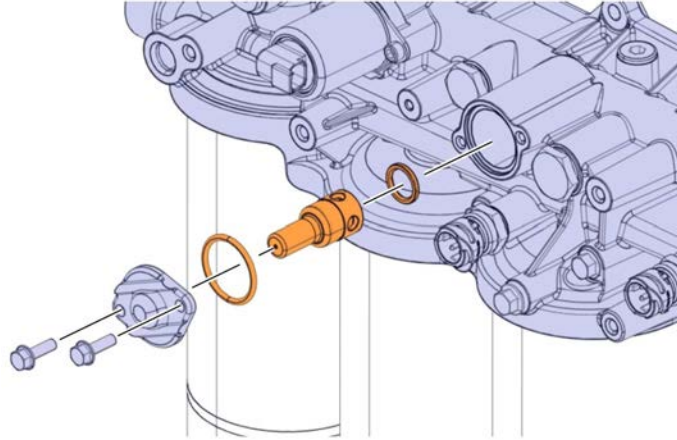

W2078671

Note: During installation of the reduction valves, the cover must be flat against the oil filter housing before the bolts are installed to ensure the valve is seated flush against the sealing surface.

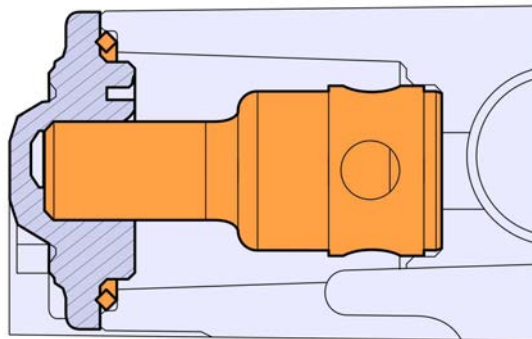

W2082022

- 4 Remove and replace the EOP Sensor (6) and Engine Piston Cooling Oil pressure Sensor (5) with new sensor part number 21634021. Tighten sensors to 30 ± 5 Nm (22 ± 4 ft-lbs).

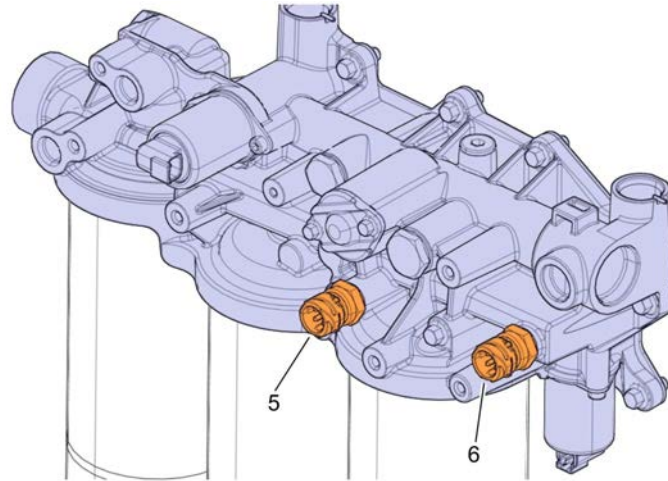

W2078872

- 5 Remove the oil pan per instructions in Impact, Procedure 2171-03-02-01 Oil Pan, Replacement.
- 6 Remove and replace the pressure reduction (relief) valve in the oil valve body with part number (22188378), and replace the internal o-ring with part number (469846). Tighten cover fasteners to 10 ± 2 Nm (88 ± 17 in-lbs).

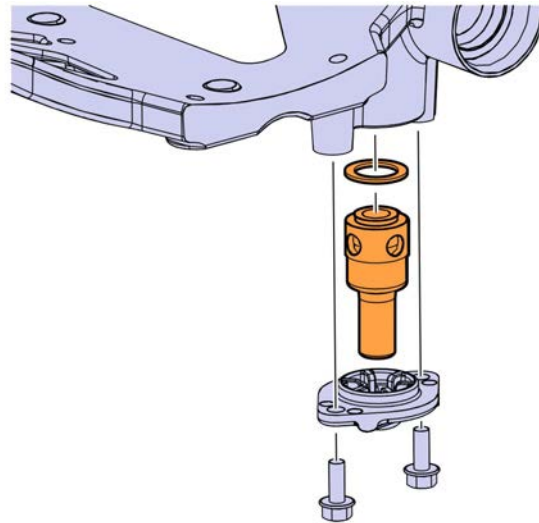

W2082023

- 7 Install the oil pan per instructions in Impact, Procedure 2171-03-02-01 Oil Pan, Replacement.
- 8 Refill the engine oil to the proper level.
- 9 Reconnect all previously removed cables to the negative (ground) battery terminals.
- 10 Start engine, check for leaks and proper operation. Clear any diagnostic trouble codes (DTC).

Reimbursement

This repair may be eligible for reimbursement if a product failure was experienced within time and mileage limits of the applicable Warranty coverage. Reimbursement is obtained via the normal claim handling process.	
Claim Type (used only when uploading from the Dealer Bus. Sys.)	01
Labor Code	
Primary Labor Code	2192C-36-80 3.1 hrs.
Causal Part	3826265

MACK Trucks North America engages in a comprehensive program of testing and evaluating to provide the best possible product. MACK Trucks North America however, is not committed to, or liable for updating existing vehicles.