



# Technical Service Bulletin

## 01 MIL on (DTC P2006(00) or P2007(00) stored in ECM)

01 13 06 2033919/5 June 18, 2013. Supersedes Technical Service Bulletin Group 01 number 13-05 dated June 7, 2013 for reasons listed below.

Model(s)	Year	VIN Range	Vehicle-Specific Equipment
A6/A7, S4, S5, S5 Cabrio, Audi Q7, Audi Q5	2013	All	3.0 FSI Engine

## Condition

REVISION HISTORY		
Revision	Date	Purpose
5	-	Revised <i>Required Parts and Tools</i> (Updated quantity)
4	6/7/2013	Revised Service (Removed step regarding calling TAC)
3	5/29/2013	Revised header data (updated engine codes)
2	5/28/2013	Revised <i>Service</i> (Added steps and image)
1	5/16/2013	Initial publication

- MIL on.
- One or both of the following DTCs is stored in the engine control module, J623 (address word 01):
  - **DTC P2006(00)** (Intake Manifold Runner Control Stuck Closed, Bank 1).
  - **DTC P2007(00)** (Intake Manifold Runner Control Stuck Closed, Bank 2).
- There may be slight power reduction at high RPMs.

## Technical Background

One of the vacuum actuators on intake runner bank 1 or bank 2 is defective.

## Production Solution

Updated vacuum actuator.

## Service

1. Identify the defective vacuum actuator. Use Guided Fault Finding (GFF), or use the vacuum pump (Figure 1) to determine which actuator is defective.



**Tip:** Even though only one actuator is defective, a large leak in the defective actuator may cause DTCs to be set for **both** banks because both are fed from the same vacuum solenoid. Ensure that the defective actuator is correctly identified.

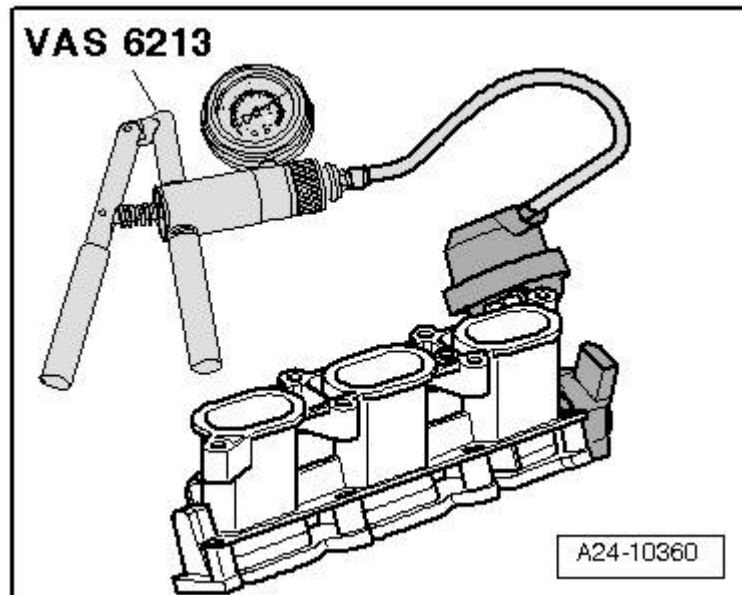

Figure 1. Vacuum pump VAS 6213

2. Replace the defective actuator using instructions from ElsaWeb. Do not replace the entire intake runner.

# Technical Service Bulletin



## Warranty

<b>Claim Type:</b>	Use applicable claim type. If vehicle is outside any warranty, this Technical Service Bulletin is informational only.		
<b>Service Number:</b>	2447		
<b>Damage Code:</b>	0010		
<b>Labor Operations:</b>	<b>Compressor remove+reinstall</b>		
	For S4, S5, S5 Cab, and Audi Q5	2114 1941	190 TU
	For A6, A7, and A8	2114 1941	160 TU
	For Audi Q7	2114 1939	160 TU
	<b>Intake runner remove+reinstall, replace actuator</b>		
	For S4, S5, S5 Cab, and Audi Q5	2447 1991	40 TU
	For A6, A7, and A8	2447 1991	40 TU
	For Audi Q7	2447 1989	40 TU
<b>Diagnostic Time:</b>	GFF	0150 0000	Time stated on diagnostic protocol (max 20 TU)
	Road test prior to service procedure	No allowance	0 TU
	Road test after service procedure	0121 0004	10 TU
	Technical diagnosis at dealer's discretion (Refer to Section 2.2.1.2 and Audi Warranty Online for DADP allowance details)		
<b>Claim Comment:</b>	As per TSB # 2033919/5		

All warranty claims submitted for payment must be in accordance with the *Audi Warranty Policies and Procedures Manual*. Claims are subject to review or audit by Audi Warranty.

## Required Parts and Tools

Part number	Part Description	Quantity
06E133159J	Actuator left (replace only the affected actuator)	1
06E133159H	Actuator right (replace only the affected actuator)	1
06E998907D	Repair kit	3
079129717B	Gasket	3
079129717D	Gasket	6
06E103213	Tube	1
G 012A8G1G	Coolant top off	0.3

Tool Number	Tool Description
VAS 6213	Vacuum pump

## Additional Information

All parts and service references provided in this TSB are subject to change and/or removal. Always check with your Parts Department and service manuals for the latest information.