



Technical Service Bulletin

SUBJECT:			No: TSB-13-42A-005
CORRECTED CIRCUIT DIAGRAMS FOR CENTRAL DOOR LOCKING (W/ KOS) & ONE TOUCH START SYSTEMS – SERVICE MANUAL REVISION			DATE: September, 2013
			MODEL: 2011-2013 Outlander Sport / RVR
CIRCULATE TO:	<input type="checkbox"/> GENERAL MANAGER	<input type="checkbox"/> PARTS MANAGER	<input checked="" type="checkbox"/> TECHNICIAN
<input checked="" type="checkbox"/> SERVICE ADVISOR	<input checked="" type="checkbox"/> SERVICE MANAGER	<input type="checkbox"/> WARRANTY PROCESSOR	<input type="checkbox"/> SALES MANAGER

PURPOSE

The circuit diagrams are incorrect in the service manual for the Central Door Locking System (vehicles with KOS) and One Touch Start System. This TSB contains the updated information.

AFFECTED VEHICLES

2011 Outlander Sport / RVR

2012 Outlander Sport / RVR

2013 Outlander Sport / RVR

AFFECTED SERVICE MANUALS

2011 Outlander Sport / RVR: Group 90 – Circuit Diagrams > Central Door Locking System <Vehicles with KOS>

2011 Outlander Sport / RVR: Group 90 – Circuit Diagrams > One Touch Start System

2012 Outlander Sport / RVR: Group 90 – Circuit Diagrams > Central Door Locking System <Vehicles with KOS>

2012 Outlander Sport / RVR: Group 90 – Circuit Diagrams > One Touch Start System

2013 Outlander Sport / RVR: Group 90 – Circuit Diagrams > Central Door Locking System <Vehicles with KOS>

2013 Outlander Sport / RVR: Group 90 – Circuit Diagrams > One Touch Start System

Continued

Copyright 2013, Mitsubishi Motors North America, Inc.

(4054)

The information contained in this bulletin is subject to change. For the latest version of this document, go to the Mitsubishi Dealer Link, MEDIC, or the Mitsubishi Service Information website (www.mitsubishitechinfo.com)

Please replace the indicated information in the 2011–2013 Outlander Sport/RVR Service Manual, Group 90: Circuit Diagrams – Central Door Locking System <Vehicles with KOS> as follows:

CIRCUIT DIAGRAMS
CENTRAL DOOR LOCKING SYSTEM <VEHICLES WITH KOS>

CENTRAL DOOR LOCKING SYSTEM <VEHICLES WITH KOS> (CONTINUED)

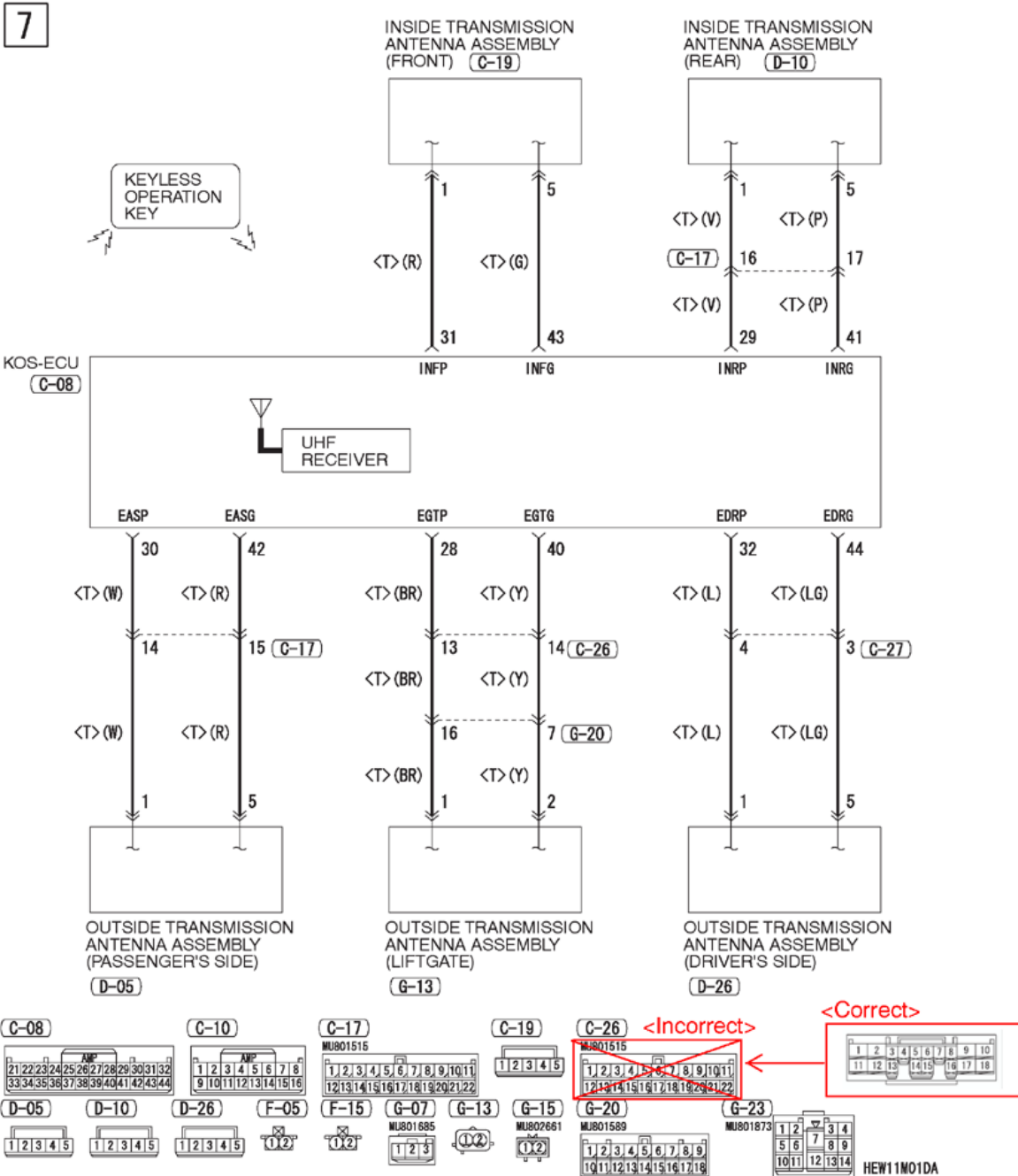

CIRCUIT DIAGRAMS
 CENTRAL DOOR LOCKING SYSTEM <VEHICLES WITH KOS>

8

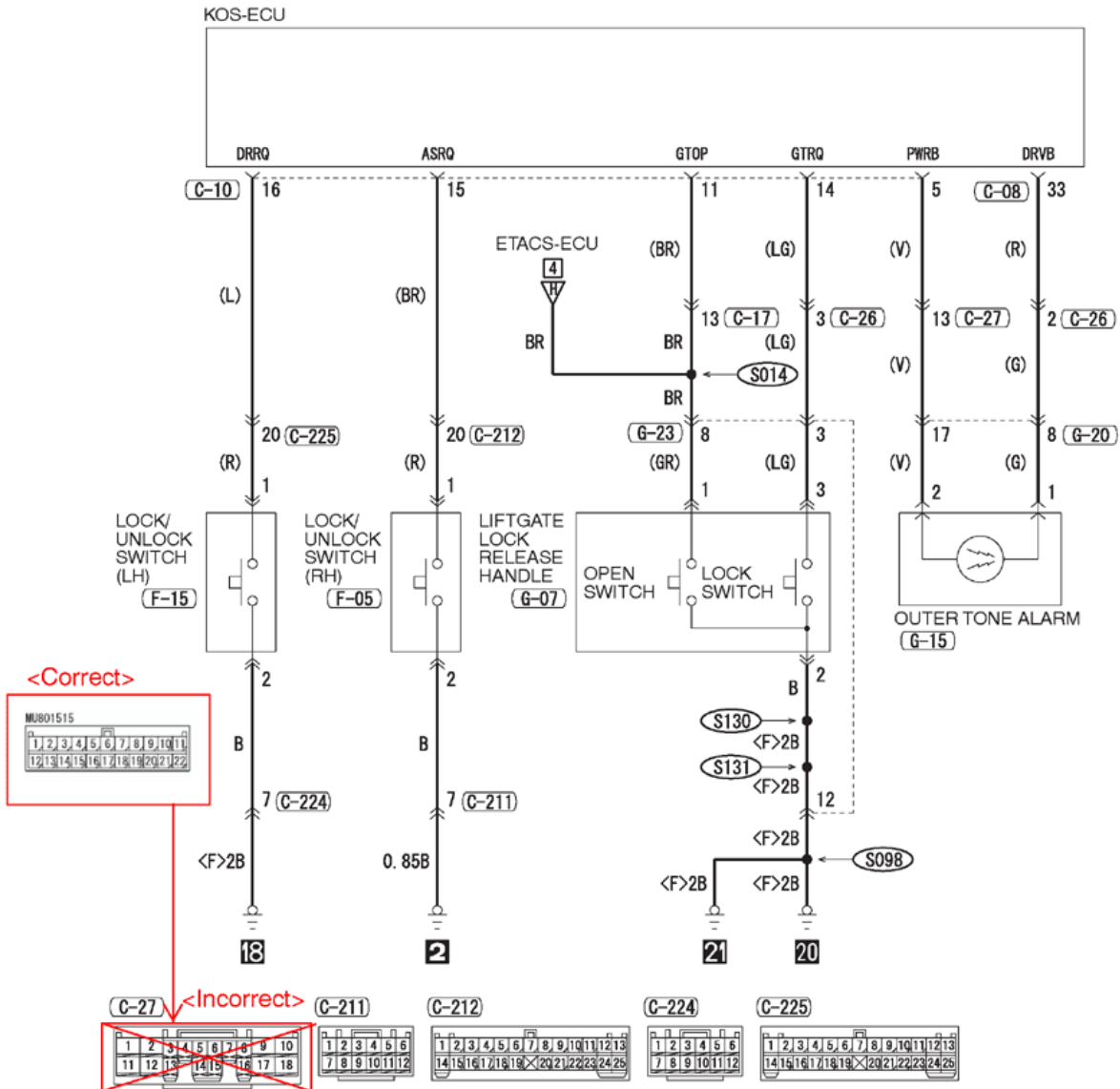

Please replace the indicated information in the 2011-2013 Outlander Sport/RVR Service Manual, Group 90: Circuit Diagrams - One Touch Start System as follows:

**CIRCUIT DIAGRAMS
 ONE TOUCH START SYSTEM**

ONE TOUCH START SYSTEM (CONTINUED)

5

