



**IMPORTANT SERVICE
INFORMATION FOR:**

- ✓ SERVICE MANAGER
- ✓ SERVICE ADVISOR
- ✓ TECHNICIAN
- ✓ PARTS DEPARTMENT
- ✓ WARRANTY PERSONNEL

BULLETIN NUMBER:
IB12-N-001A

ISSUE DATE:
DECEMBER 2013

GROUP:
ELECTRICAL

No Crank/No Start, No Scan Tool Communication – Extreme Cold Weather

AFFECTED VEHICLES

- 2007-2014MY Isuzu N-Series
Equipped with 5.2L (4HK1) Diesel Engine and Diesel Particulate Filter (DPF)

This bulletin supersedes IB12-N-001. This bulletin is being revised to update model years. Please discard bulletin IB12-N-001.

INFORMATION

This bulletin applies to specific regions in Canada and Alaska where ambient daytime temperatures can drop below **-20 degrees C**.

Some customers may experience a no crank/no start condition when ambient temperatures drop to or below -20 degrees C. Vehicles equipped with Multi Information Display (MID) will show the error code P1464. In most cases, this condition is the result of a stuck ECM Main Relay (X-30). This condition can be confirmed by connecting IDSS. If IDSS cannot communicate with the vehicle, the ECM has not powered up due to the frozen X-30 Relay.

Note: If IDSS communicates normally, it is not a frozen relay. Follow normal diagnostics to correct the concern.

Isuzu is happy to announce the availability of a new relay with improved performance for this condition. Installation of the new relay requires a small modification to the relay box cover. Follow the service procedure provided in this bulletin to properly install this new relay.

SERVICE INFORMATION

1. Remove relay box cover.
2. Remove the original ECM Main Relay in location X-30.
3. Install the new relay at location X-30.
4. Locate the relay box cover rib as shown in figure 1.

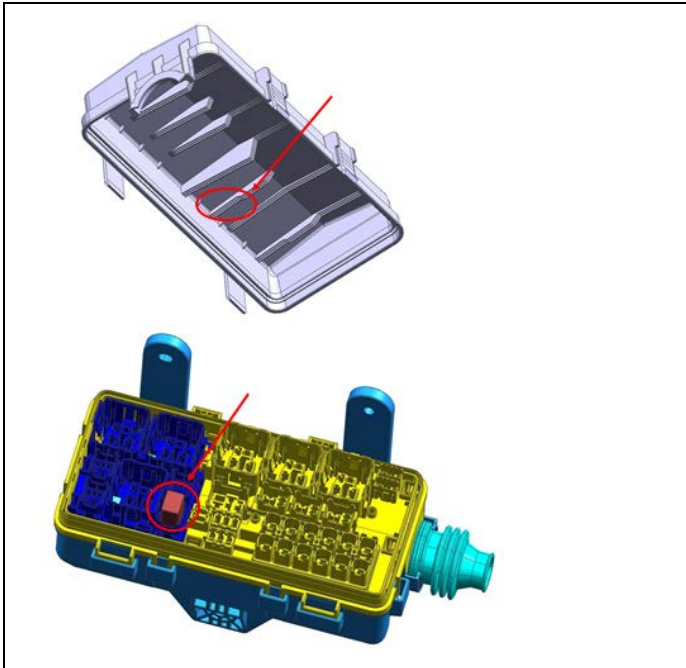

Figure 1
Locate X-30 relay and relay cover rib

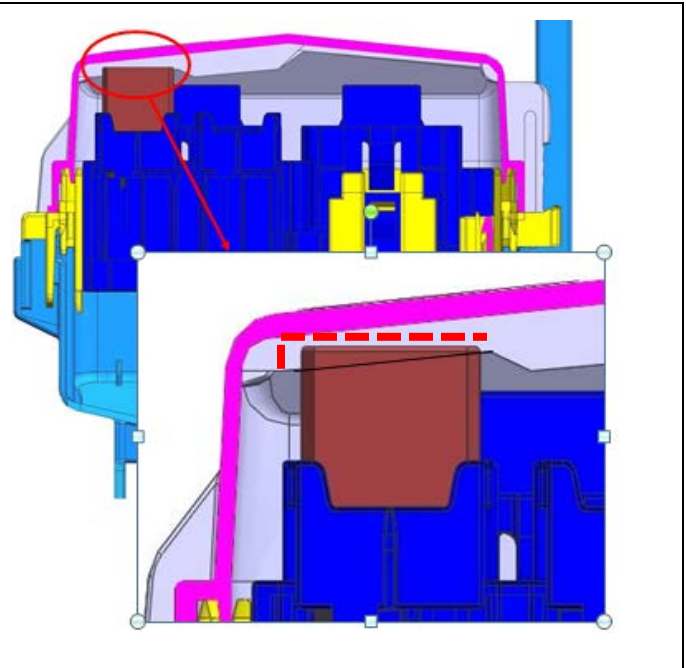

Figure 2
Cut at dashed line

5. Trim the relay cover rib approximately 3 mm to provide clearance for the new relay.
6. Install the relay cover and confirm it seals properly. If the cover does not close properly, trim additional material from the cover until it seals.

PARTS INFORMATION

Parts can be ordered from American Isuzu Parts Distribution Network (AIPDN).

Part Number	Description	Qty
8-98167-260-0	Relay	1

WARRANTY INFORMATION

For vehicle repaired under warranty, use the labor operation code provided below.

Operation Code	Description	Labor Time
N2821	Relay – Fuel System – Replace	See Published Labor Time
N2827	Powertrain System – Replace	See Published Labor Time